

Candidate Name

Centre Number

Candidate Number



ZIMBABWE SCHOOL EXAMINATIONS COUNCIL
General Certificate of Education Ordinary Level

COMBINED SCIENCE

4003/1

PAPER 1 Multiple Choice

NOVEMBER 2023 SESSION

1 hour

Additional materials:
Multiple Choice answer sheet
Soft clean eraser
Soft pencil (type B or HB is recommended.)
Calculator (Optional)

TIME 1 hour

INSTRUCTIONS TO CANDIDATES

Do **not** open this booklet until you are told to do so.

Write your name, Centre number and candidate number on the answer sheet in the spaces provided unless this has already been done for you.

Read very carefully the instructions on the answer sheet.

INFORMATION FOR CANDIDATES

Each correct answer will score **one** mark. A mark will **not** be deducted for a wrong answer. Any rough working should be done in this booklet.

There are **forty** questions in this paper. Answer **all** questions. For each question, there are four possible answers, **A, B, C** and **D**. Choose the one you consider correct and record your choice in soft pencil on the separate answer sheet provided.

This question paper consists of 13 printed pages and 3 blank pages.

Copyright: Zimbabwe School Examinations Council, N2023.

- 1 The diagram shows some of the structures that can be seen on an electron micrograph of a cell.

Which structure is a mitochondrion?

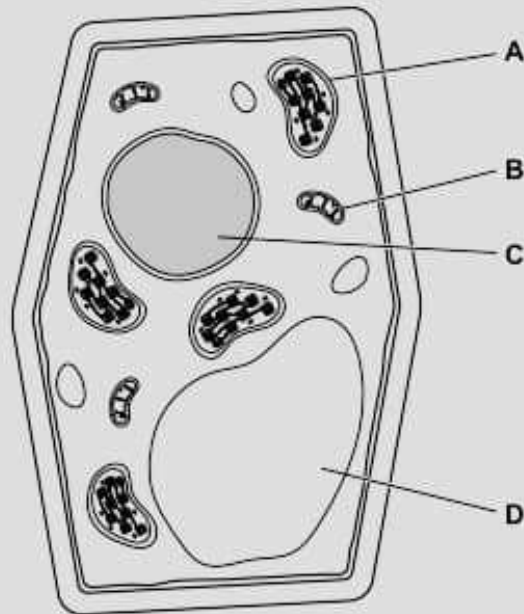

- 2 Which row is true for osmosis?

	direction of net water movement	type of membrane
A	higher water potential to lower water potential	fully permeable
B	higher water potential to lower water potential	partially permeable
C	lower water potential to higher water potential	fully permeable
D	lower water potential to higher water potential	partially permeable

- 3 Which graph shows the effect of temperature on the rate of enzyme activity for an enzyme from human cells?

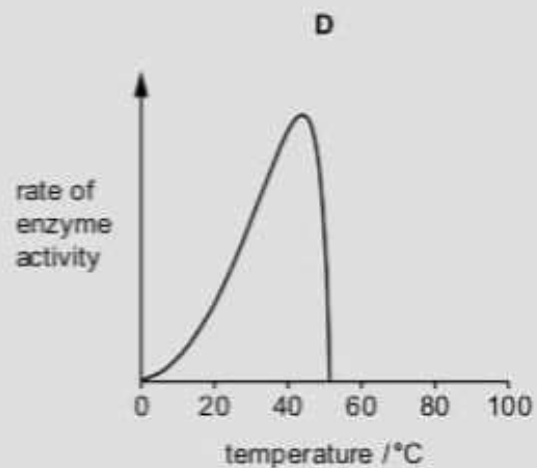
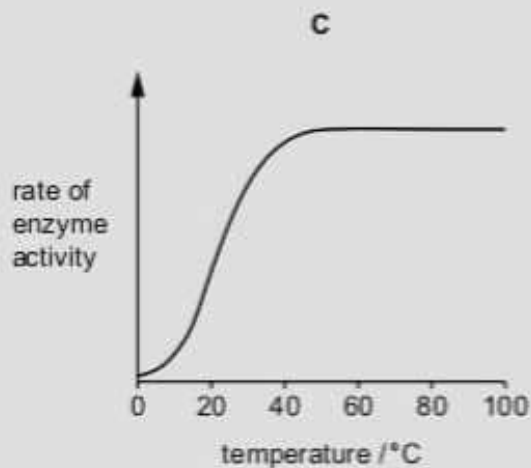
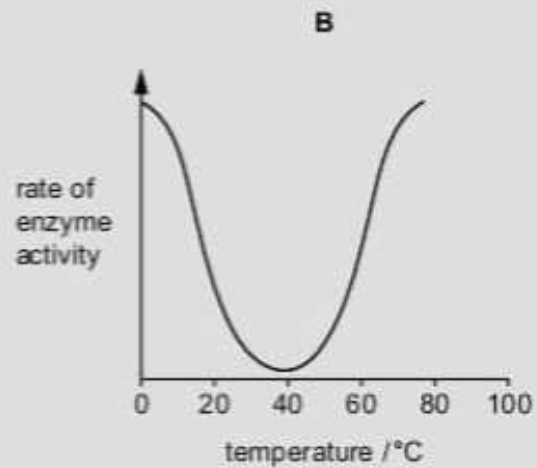
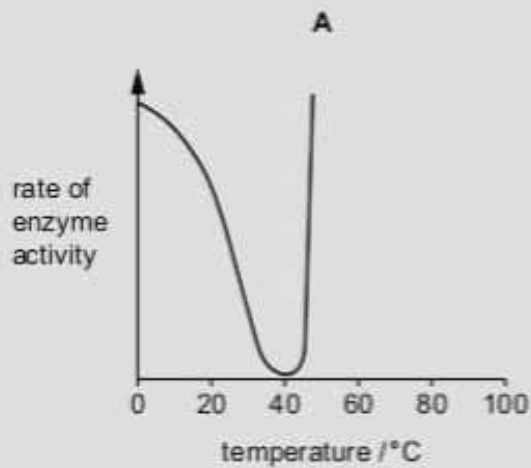

- 4 During transpiration, water evaporates from the surface of which type of cell?

- A mesophyll
- B phloem
- C root cortex
- D xylem

- 5 Which blood vessel transports blood from the ileum to the liver?

- A hepatic artery
- B hepatic portal vein
- C pulmonary artery
- D pulmonary vein

- 6 The diagram shows the volume of air in the lungs over a period of 30 s for a person at rest.

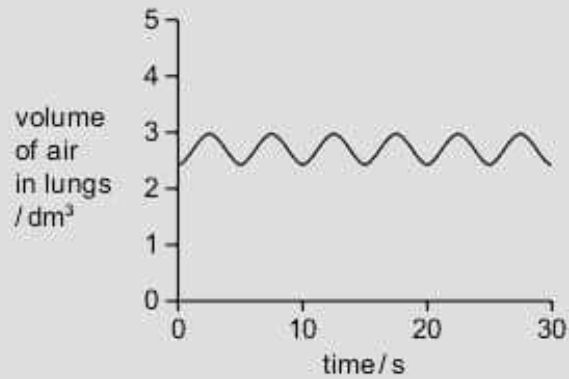

Which graph shows the same person doing vigorous exercise over another period of 30 s?

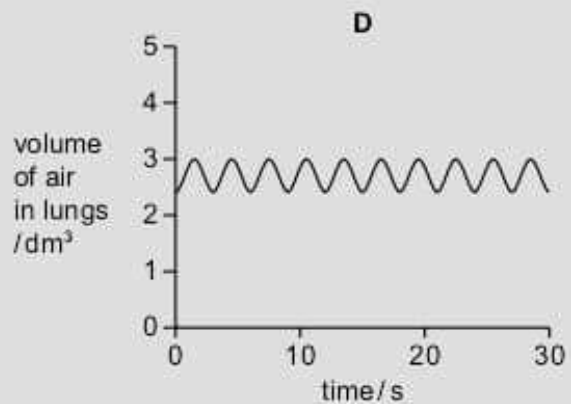
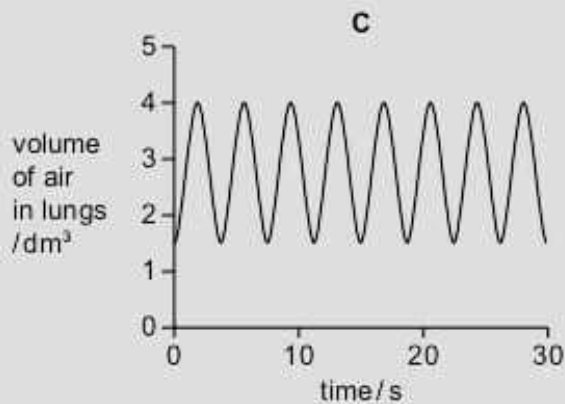
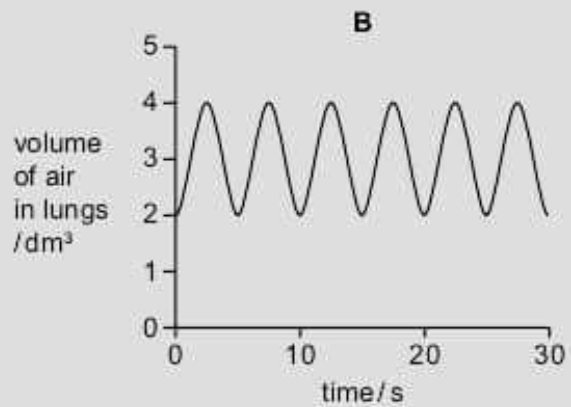
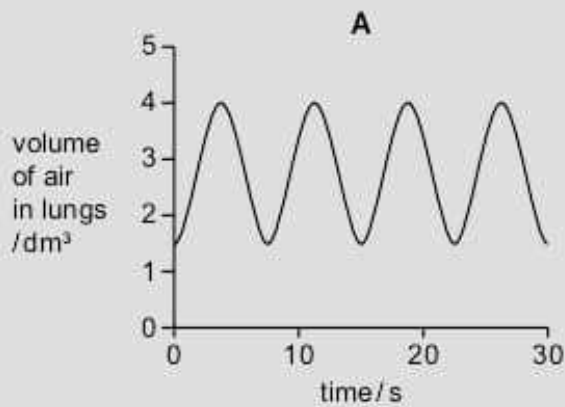

- 7 The photomicrograph shows some blood cells.



What is the function of these cells?

- A blood clotting
 - B engulfing pathogens
 - C producing antibodies
 - D transporting oxygen
- 8 A person touches a hot object. This causes a reflex action.

Which row shows the pathway of a reflex arc?

	1	2	3	4	5
A	receptor	sensory neurone	relay neurone	motor neurone	effector
B	receptor	motor neurone	sensory neurone	relay neurone	effector
C	effector	sensory neurone	relay neurone	motor neurone	receptor
D	effector	motor neurone	sensory neurone	relay neurone	receptor

- 9 What is the definition of a gene?
- A all of the DNA in a cell that controls metabolic activity
 - B a specific section of DNA which codes for the synthesis of a protein
 - C the nucleus and its chromosomes
 - D the total number of chromosomes in an organism

- 10 The diagram shows the female reproductive system in humans.

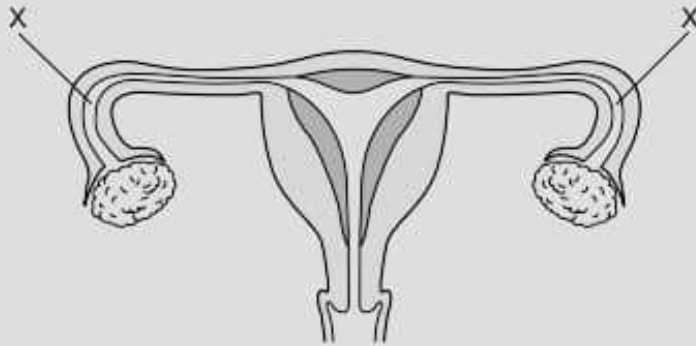

Sometimes the tubes labelled X become blocked. What effect does this have?

- A Eggs cannot reach the uterus.
 - B Menstruation is prevented.
 - C Release of an egg is prevented.
 - D Sperm cannot reach the uterus.
- 11 Genetic modification can be used to produce crops that are resistant to insect pests and can produce more vitamins.

Which statements about genetic modification are true?

- 1 Genes can be inserted.
- 2 Genes can be changed.
- 3 Genes can be removed.

- A 1 and 2 only B 1 and 3 only C 2 and 3 only D 1, 2 and 3
- 12 What is the principal source of energy input to most biological systems?
- A animals
 - B plants
 - C the Sun
 - D water

- 13 The concentration of carbon dioxide in the Earth's atmosphere has increased over the last 60 years.

Which activity has contributed to this increase?

- A deforestation of large areas of land
 B development of renewable fuels
 C introduction of new plant species to ecosystems
 D increased use of genetic modification in plants
- 14 Hydrogen can occur as an atom, an ion and a molecule.

Which row represents the formulae of these particles?

	atom	ion	molecule
A	H	H ⁺	H ₂
B	H	H ₂	H ⁺
C	H ⁺	H	H ₂
D	H ₂	H ⁺	H

- 15 Which statement describes what happens to an atom of a Group II element when it forms a compound with oxygen?

- A It bonds with two atoms of oxygen.
 B It receives two electrons from an atom of oxygen.
 C It shares two electrons with an atom of oxygen.
 D It transfers two electrons to an atom of oxygen.
- 16 Which statements explain why copper is used to make electrical wires?

- 1 Copper is a good conductor of electricity.
- 2 Copper is a good conductor of heat.
- 3 Copper is malleable.

- A 1 only B 1 and 2 C 1 and 3 D 2 and 3

17 The structure of a compound is shown.

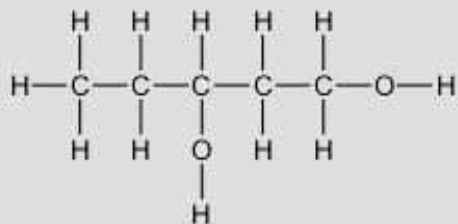

What is the formula of this compound?

- A $\text{C}_5\text{H}_{11}\text{O}$
- B $\text{C}_5\text{H}_{11}\text{O}_2$
- C $\text{C}_5\text{H}_{12}\text{O}$
- D $\text{C}_5\text{H}_{12}\text{O}_2$

18 An incomplete equation for the reaction between ethyne, C_2H_2 , and oxygen is shown.



When the equation is balanced, what is x ?

- A 3
- B 5
- C 6
- D 10

- 19 When aqueous sodium hydroxide and dilute hydrochloric acid are mixed, they react.

The graph shows how the temperature of the mixture changes over time.

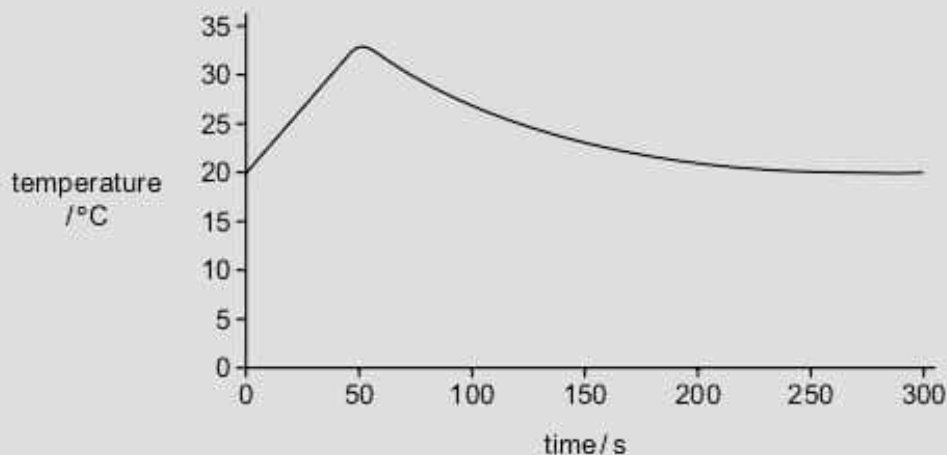

Which type of chemical reaction occurs between aqueous sodium hydroxide and dilute hydrochloric acid?

- A both endothermic and exothermic
 - B endothermic
 - C exothermic
 - D neither endothermic nor exothermic
- 20 Marble and chalk are both types of calcium carbonate.

Equal masses of marble lumps and powdered chalk are added to excess dilute hydrochloric acid.



Which statement explains why the marble takes longer to fully react than the chalk?

- A It is more reactive than the chalk.
- B It is more soluble than the chalk.
- C It has a smaller surface area than the chalk.
- D It is more basic than the chalk.

- 21 Magnesium reacts with carbon dioxide to produce magnesium oxide and carbon.

What happens to the magnesium in this reaction?

- A It gains oxygen and is oxidised.
- B It loses oxygen and is oxidised.
- C It gains oxygen and is reduced.
- D It loses oxygen and is reduced.

- 22 Which row describes an alkali?

	solubility in water	reaction with an acid
A	soluble	does not react
B	soluble	reacts
C	insoluble	does not react
D	insoluble	reacts

- 23 Lithium is a metal in Group I of the Periodic Table.

Which row describes the properties of lithium?

	hardness	melting point
A	hard	highest in Group I
B	hard	lowest in Group I
C	soft	highest in Group I
D	soft	lowest in Group I

- 24 Metal X reacts rapidly with cold water.

Metal Y does not react with dilute hydrochloric acid.

Which row describes the reactivities of metal X and metal Y?

	reactivity of metal	reactivity compared to hydrogen
A	X is more reactive than Y	X is less reactive than hydrogen
B	X is more reactive than Y	X is more reactive than hydrogen
C	Y is more reactive than X	Y is less reactive than hydrogen
D	Y is more reactive than X	Y is more reactive than hydrogen

25 Air is a mixture of gases.

The diagram shows the percentage composition of the gases in clean, dry air.

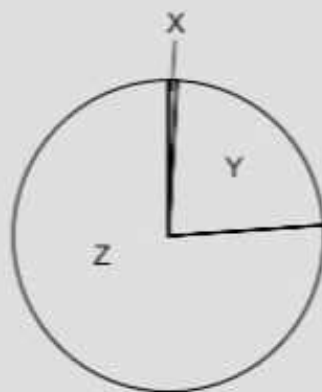

What are X, Y and Z?

	X	Y	Z
A	N_2	O_2	noble gases, CO_2
B	noble gases, CO_2	N_2	O_2
C	noble gases, CO_2	O_2	N_2
D	O_2	noble gases, CO_2	N_2

26 The diagram shows the fractional distillation of petroleum.

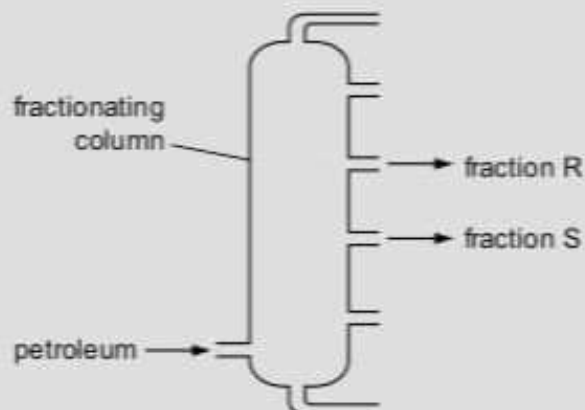

Which row explains why fraction R is collected above fraction S?

	boiling point of R	average molecular mass of R
A	lower than S	greater than S
B	lower than S	smaller than S
C	higher than S	greater than S
D	higher than S	smaller than S

27 Which row describes alkenes?

	saturated or unsaturated	result when shaken with aqueous bromine
A	saturated	no change
B	saturated	bromine is decolourised
C	unsaturated	no change
D	unsaturated	bromine is decolourised

28 A motor racing track is 3.0 km in length. A car travels round the track 25 times in 30 minutes.

What is the average speed of the car?

- A** 75 km/hour
- B** 90 km/hour
- C** 150 km/hour
- D** 750 km/hour

29 Which object has the largest resultant force acting on it?

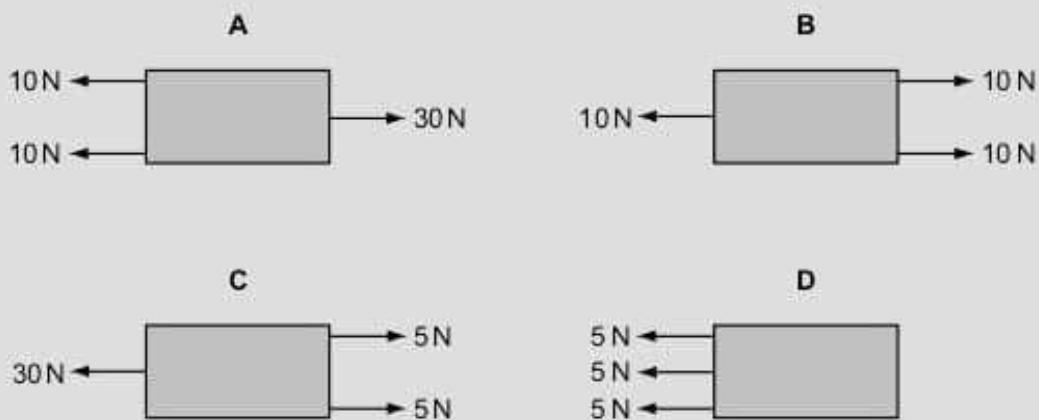

30 The diagram shows a block being pulled up a ramp by a rope.

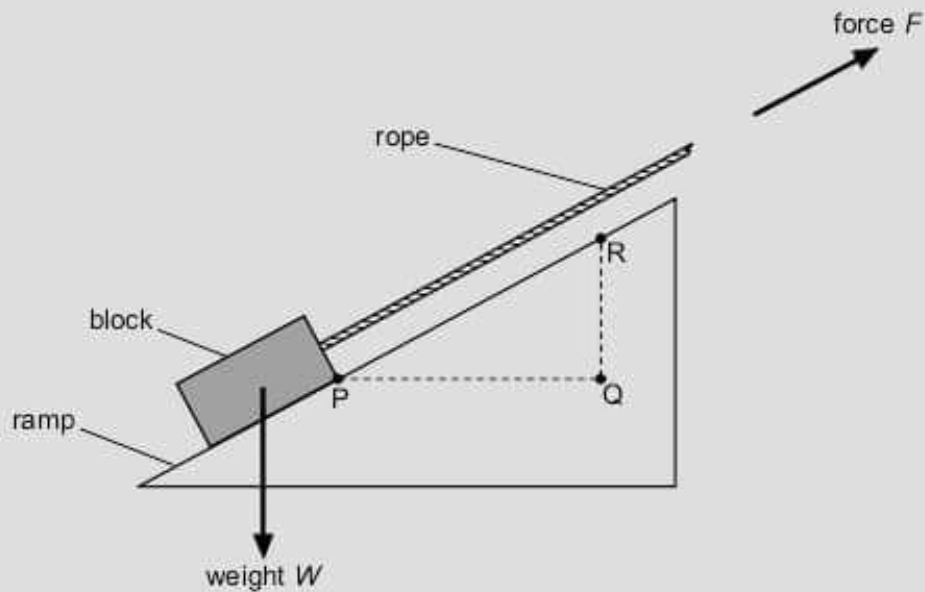

The block has weight W and the rope is pulled with force F .

The block moves distance PR and is raised through height QR .

What is the equation for the work done on the block by the rope?

- A force $F \times$ distance PR
 - B force $F \times$ height QR
 - C weight $W \times$ distance PQ
 - D weight $W \times$ distance PR
- 31 What is the source of the energy transferred by a hydroelectric power station?
- A chemical energy of oil
 - B gravitational potential energy of water
 - C kinetic energy of waves
 - D internal energy of hot rocks

- 32 Ice is used to decrease the temperature of warm water in a glass.

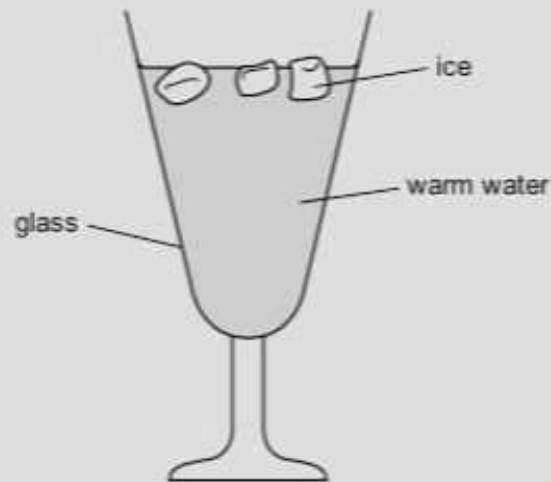

What is the main process by which the temperature of the water at the bottom of the glass decreases?

- A condensation
 - B conduction
 - C convection
 - D radiation
- 33 An engineer wants to fit a steel washer onto a steel rod. The rod is slightly too big to fit into the hole of the washer.

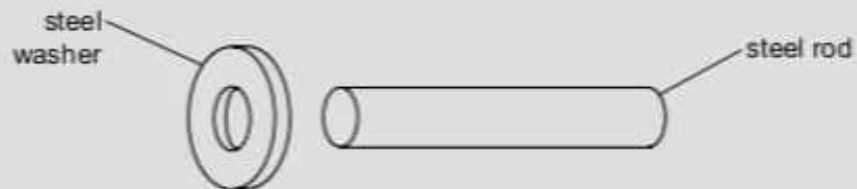

What can the engineer do to fit the washer onto the rod?

- A Cool the washer and rod to the same temperature.
- B Cool the washer only.
- C Heat the rod only.
- D Heat the washer only.

- 34 A ray of light in air is incident on the surface of water. Some light is reflected and some light is refracted.

Which line represents the reflected ray?

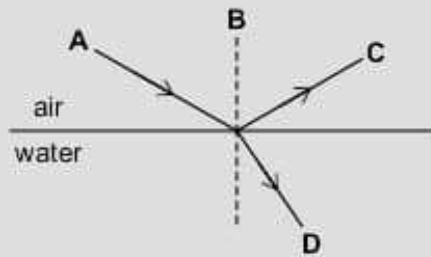

- 35 Regions of the electromagnetic spectrum are used in different applications.

Which application uses a region of the electromagnetic spectrum with a shorter wavelength than visible light?

- A Bluetooth
 - B security scanners
 - C television
 - D thermal imaging
- 36 An electrical appliance has a power rating of 0.60 kW. The cost of electricity is 7.0 cents/kWh.
- What is the cost of using the electrical appliance for 2 hours?
- A 2.1 cents B 5.8 cents C 8.4 cents D 23 cents

- 37 The circuit diagrams include an ammeter, a voltmeter and a lamp in different arrangements.

Which arrangement can be used to obtain readings to calculate the power of the lamp?

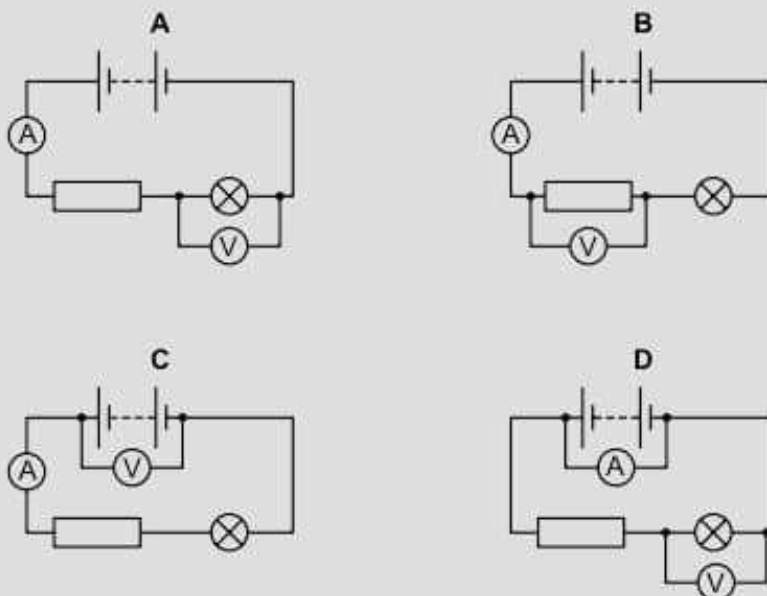

- 38 Double insulation is used to protect users of some appliances.

Where is the double insulation located and which wire is **not** needed by a double insulated appliance?

	location of double insulation	wire that is not needed
A	casing	earth wire
B	casing	neutral wire
C	plug	earth wire
D	plug	neutral wire

- 39 Unstable nuclei emit radiation. Two types of radiation emitted are:

- electromagnetic radiation
- helium nuclei.

Which of these types of radiation is used in each of these applications?

	household smoke detection	crack detection in metals
A	electromagnetic radiation	electromagnetic radiation
B	electromagnetic radiation	helium nuclei
C	helium nuclei	electromagnetic radiation
D	helium nuclei	helium nuclei

- 40 The diagram shows part of a machine that is used to measure and control the thickness of paper being made in a factory.

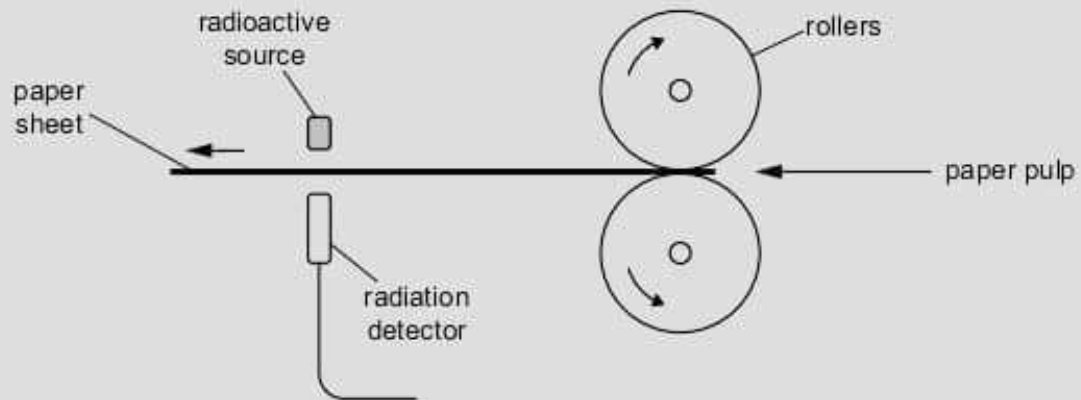

Which of the rows shows the most suitable properties for the radioactive source used in this machine?

	radiation emitted by source	half-life of source
A	alpha	1 hour
B	alpha	5 years
C	beta	1 hour
D	beta	5 years