

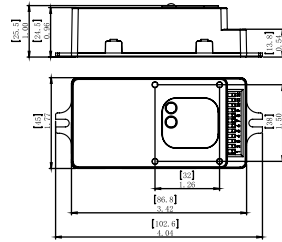

WEC-2MDH-35



WEC-3RC
(OPTIONAL)



SPECIFICATIONS

Power supply	120/277VAC 50/60Hz
Maximum load @ -40°F ~ +158°F (-40°C ~ +70°C)	Resistive/Tungsten - 600W@120V Electronic Ballast (LED) - 800VA@120V/1200VA@277V
HF System	5.8GHz CW
Dim control output	0-10V, max. 25mA sinking current
Detection radius/angle	Max 26ft.(8m) /360°
Mounting height	Max 40ft
Humidity	Max. 95% RH
Temperature	-40°F ~ +158°F (-40°C ~ +70°C)

NOTE: The high-frequency output of this sensor is <math><0.2\text{mW}</math>-that is just one 5000th of the transmission power of a mobile phone or the output of a microwave oven.

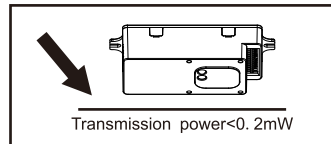

SENSOR COVERAGE

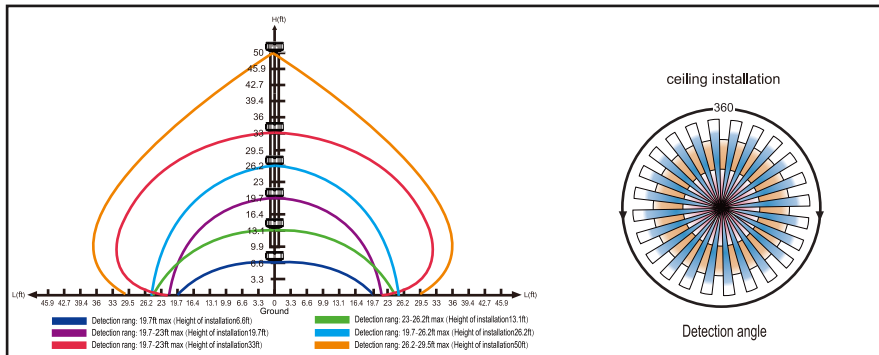

⚠ WARNING

NOTE: Warm up time is 15seconds. After the sensor connects input power, the light will keep on 15seconds, then go to dimming to work normally.

NOTE: Factory Default Setting: 100% sensitivity, Hold on time: 10seconds, Daylight sensor is 30lux, Dimming level:30%, Dimming time: 60minutes.

NOTE: Any setting changed by DIP Switch or remote control, the light that sensor connect will on/off as confirm.

UTILIZING FIELD AND INTRODUCTION

WEC-2MDH-35 is a moving object sensor that can detect range of 360° and it's working frequency is 5.8GHz. The advantage of this product is stable working state (stable working temperature: -40°C~+70°C), WEC-2MDH-35 adopts a microwave sensor (high-frequency output <math><0.2\text{mW}</math>), so that it is safe and performs better than infrared sensor.

FUNCTION AND OPTIONS

Daylight Harvesting Function

A control method based on the control of artificial light with available natural light. The purpose is to control the output of artificial light according to the change of natural light, while ensuring that the illumination of the target space does not change to maintain a certain illumination.

ON-OFF Function

Switch on the lamp on detection of movement, and switch off after a hold time when there is no motion detected. As built-in daylight sensor can read brightness value, the sensor does not switch on the lamp if with sufficient natural light.



The lamp will not switch on when natural light is sufficient, even there is motion detected.

The lamp switches on automatically with presence when natural light is insufficient.

The lamp turns on at full or dims to maintain the lux level. The lamp output regulates according to the level of natural light available.

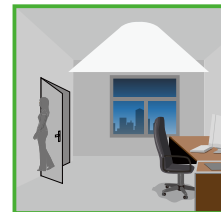

The lamp dims to stand-by period after hold-time and stays on selected minimum dimming level.



The lamp switches off completely after the stand-by period.

WIRING DIAGRAMS

Wiring with dimming ballast or LED driver.

Dimming Driver

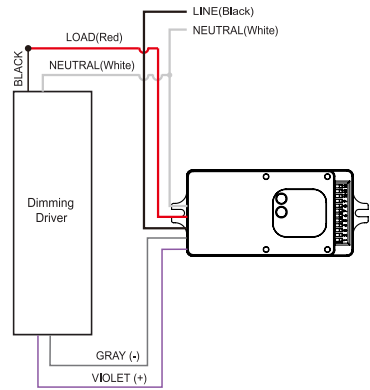

Wiring with non-dimming ballast or LED driver.

Non-Dimming Driver

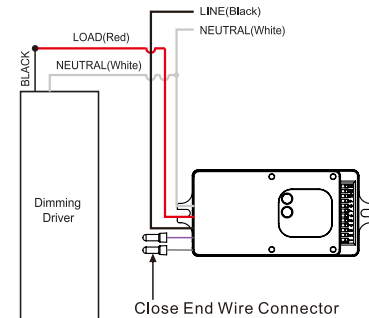

PARAMETER SETTING BY DIP SWITCH

Consider the picture: 1, 2 set sensitivity; 3, 4,5 set hold time; 6, 7,8 set stand-by time; 1, 2 set the light-control ; 3, 4 set stand-by light level ;

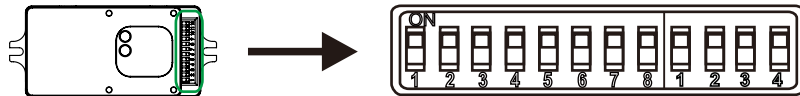

Detection Range Setting (sensitivity)

Detection rang can be reduced by selecting the combination on the DIP switches to fit precisely each application:

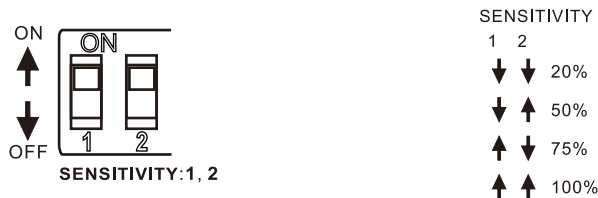

Hold Time Setting

The lamp can be set to stay ON for any period of time between approx. 10sec and a maximum of 30min. Any movement detected before this time elapse will re-start the timer. It is recommended to select the shortest time for adjusting the detection zone and for performing the walk test. Switch location and hold time of the corresponding table is as follows:

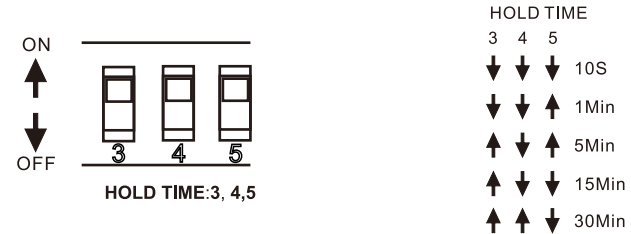

Stand-by Time Setting

File of switch location and stand-by time setting as follow:

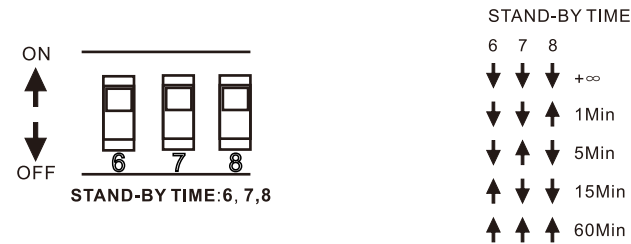

Light-control Setting

The chosen lamp response threshold can be infinitely from approx. 10-50lux, switch location and light-control of the corresponding table is as follows:

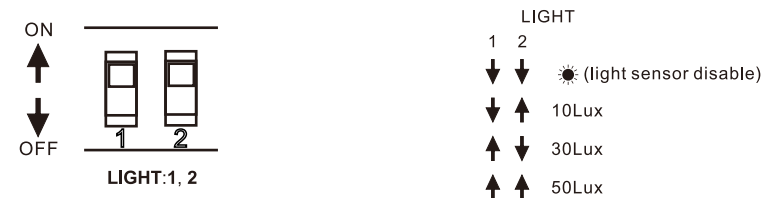

Stand-by Light Level Setting

The corresponding file of switch location and stand-by level as follows:



PARAMETER SETTING BY REMOTE CONTROL IN MANUAL OF WEC-3RC.