

WMC SERIES OUTDOOR LIGHTING

WMC-UDL-RGBW-BK
WMC-UDL-RGBW-WH

WESTGATE
THE FUTURE IS HERE...AND IT'S QUITE BRIGHT!

Customer Name: _____

Project Name: _____

Note: _____ Type: _____



Selection:

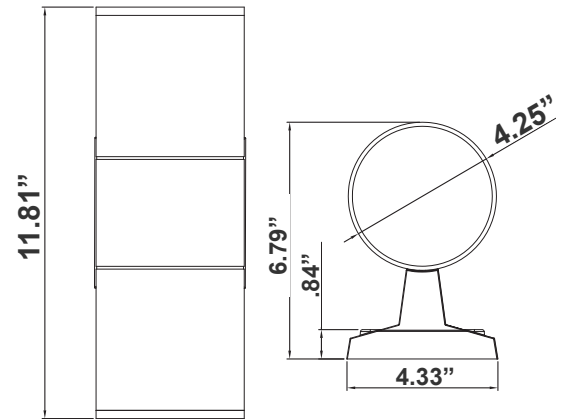

6.79"(D) x 11.81"(H) x 4.33"(W)

Ideal for general site lighting, walkways, and stairways, alleys, loading docks, doorway, pathway and parking areas

Features

- Finish: Black & White
- Compatible with Westgate Smart App, Amazon Alexa, Amazon Echo, Google Home. Connects via WIFI or Bluetooth
- 7-Year Warranty
- Outdoor UP/Down Light

Technical Specifications

Electrical:

- Voltage: 120V AC
- Power Factor: >0.90
- Wattage: 24W
- Efficacy: 100 LPW
- THD: <20%

Lighting:

- Dimming: TRIAC Dimming
- RGBW: 15 Million Colors + 2700K~5000K White Tuning
- Total Lumens: 2400LM
- Color Rendering Index: CRI ≥ 80
- Beam angle: 45° for each side
- Rated life: 70,000 hrs

Mechanical:

- This Fixture is Bluetooth mesh Enabled. Bluetooth mesh networking enables many-to-many (m:m) device communications and is optimized for creating large-scale device networks. It is ideally suited for control monitoring and automation solutions that require tens, hundreds or thousands of devices to communicate with one another
- Housing: Die-cast Aluminum & Glass
- Finish: Black & White
- Maximum Ambient Temperature: -68°F to 104°F
- Suitable for Wet Location
- 7-Year Warranty

Applications:

- Ideal for general site lighting, walkways, and stairways, alleys, loading docks, doorway, pathway and parking areas



Phone: (877) 805-2252 | Fax: (877) 805-2252
www.westgatemfg.com



WG-Z7-26-2Z

Photometrics: WMC-UDL-RGBW

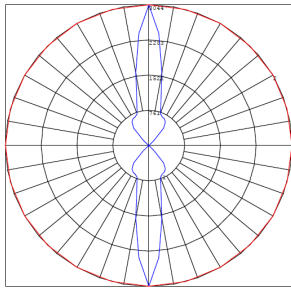
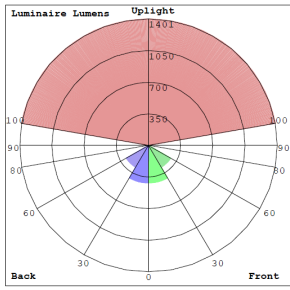

BUG Rating: B1-U5-G0

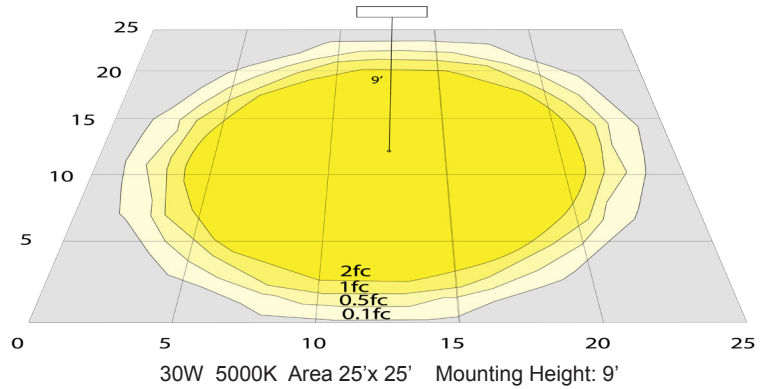

Other Views:

Black Finish:

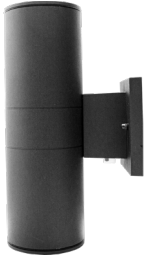

Side View



Front View



Back View



Lens View

White Finish:

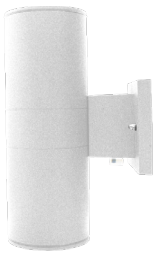

Side View



Front View



Back View



Lens View

Performance Table: WMC-UDL-RGBW

MODEL NO.	Wattage	Voltage	Lumens	Color Temp.	BUG Rating	LPW
WMC-UDL-MCT-BK-DT	24W	120V	2400LM	RGBW	B1-U5-G0	100
WMC-UDL-MCT-WH-DT	24W	120V	2400LM	RGBW	B1-U5-G0	100

Sample Ordering

Model Light Direction Color Temp. Finish

WMC - UDL - RGBW - []

BK = Black
WH = White

Factory-Installed Option:

[]

Blank = No Option For Accessories
OPT-PC-B = FOR 120V-277V PHOTOCELL
OPT-EM-OD1INT = INTERNAL EMERGENCY BACK UP BATTERY

Example:

1. WMC-UDL-RGBW-WH (FOR WMC 30W UP/DOWN LIGHT RGBW FIXTURE 120V)
2. WMC-UDL-RGBW-WH OPT-PC-B (FOR WMC 30W UP/DOWN LIGHT RGBW FIXTURE 120V) (FOR 120V-277V PHOTOCELL)

FACTORY-INSTALLED OPTION:



OPT-PC-B
FOR 120V-277V PHOTOCELL



OPT-EM-OD1INT
INTERNAL EMERGENCY
BACK UP BATTERY





Westgate Smart
Download the Smart life App



- For Setting Up The Light(s), Initial Internet Connection or Mobile Data Is Required.
 - After the Initial Setup, Internet Connection is not Necessary Anymore. The lights Can Be Controlled with The Mobile App on The Phone or Tablet. Features Such as Dimming, Changing Colors, Lights Scenes, etc.
 - Scheduling Feature Requires Internet Connection.
 - Bluetooth Devices Need a Gateway (Sold Separately) In Order to Connect to WiFi Network (Internet)
-

