

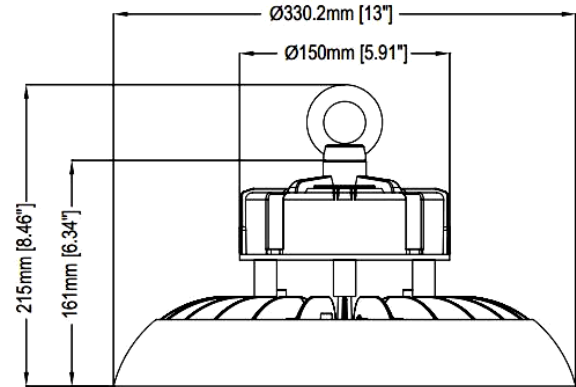

DIMENSIONS:

13"(D) x 8.46"(H)



ULHB-150W-50K-480V

LED HIGH-LUMEN UFO HIGH BAY

Ideal for general site lighting, alleys, loading docks, doorway, pathway and parking areas.

ELECTRICAL SPECIFICATIONS:

- Voltage: 480V 50/60Hz
- Wattage: 150W
- Power factor: >0.9
- Efficacy: 130LM/W
- THD: <20%

HOUSING SPECIFICATIONS:

- Housing: ACD12 aluminum heat sink, SUS black plate. outdoor powder coating
- Aluminum LED Board: High conductive, waterproof, aging resistant, salt mist resistance, long-life
- Cord type: 6' SJTW 18/3 AWG cable
- Operating temperature: -4°F ~ 122°F

CERTIFICATIONS: UL, DLC



MODEL	WATTS	VOLTAGE	LUMENS	COLOR TEMP
ULHB-150W-50K-480V	150W	480V	19500 LM	5000K

LIGHTING SPECIFICATIONS:

- Dimming: 0~10Dimmable
- Total lumens: 19500LM
- Color temperature: 5000K
- Color rendering index: >80
- Beam angle: 110°

WARRANTY: 7 years



ULHB-150W-50K-480V

LED HIGH-LUMEN UFO HIGH BAY

MODEL	WATTS	VOLTAGE	LUMENS	COLOR TEMP
ULHB-150W-50K-480V	150W	480V	19500 LM	5000K

OPTIONAL ACCESORIES:



ULHB-PCR-100/150



ULHB-ALR-100/150



ULHB-90KIT-100/150

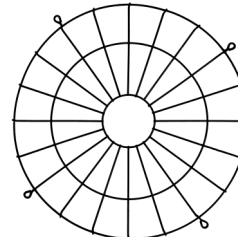

ULHB-WG-100/150



ULHB-SC-100/150



ULHB-PCC-100/150



ULHB-SMB-100/150

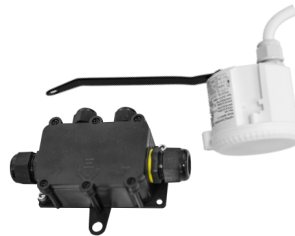

ULHB-SK

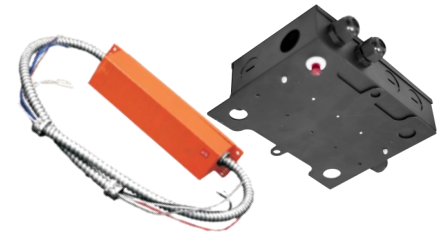

ULHB-EMK

MODEL	DESCRIPTION
ULHB-PCR-100/150	Polycarbonate Reflector for 100W & 150W
ULHB-ALR-100/150	Aluminum Reflector for 100W & 150W
ULHB-90KIT-100/150	90° Degree Reflector and Glass Kit for 100W & 150W (Conversion from default 110° beam angle)
ULHB-WG-100/150	Wire Guard for 100W & 150W
ULHB-SC-100/150	Safety Cable for 100W & 150W
ULHB-PCC-100/150	Polycarbonate Cover for 100W & 150W (for ULHB-PCR-100/150 only) - Increases heat captured in the reflector. Not recommended when not necessary.
ULHB-SMB-100/150	Surface Mount Bracket for 100W & 150W
ULHB-SK	Ultrasonic Bi-Level (Dimming) Motion Sensor Kit for 120~277V UFO High Bays. Includes special junction box (mounts on fixture), auxiliary cable & push-in connectors
ULHB-EMK	Emergency Battery Backup Kit for 120~277V UFO High Bays (All wattages) Emergency output power: 11W~28W, Emergency operation: ≥90 mins., Recharge: 48 Hrs. Includes special junction box with test button (mounts on fixture), auxiliary cables & splicers & push-in connector



ULHB-150W-50K-480V

LED HIGH-LUMEN UFO HIGH BAY

0~10V DIMMER FOR ULHB:

MODEL	WATTS	VOLTAGE	LUMENS	COLOR TEMP
ULHB-150W-50K-480V	150W	480V	19500 LM	5000K

MANUFACTURER OF BRAND	MODEL NUMBER
Lutron	DVSTV
Lutron	DVTV
Lutron	DS710
Cooper	SF10P
Hubbell	LHD-IRS3-N-WH

