

JOB NAME: \_\_\_\_\_

DATE: \_\_\_\_\_

TYPE: \_\_\_\_\_



**DIMENSIONS:**

Ø14"(OD) x 5.5"(H)

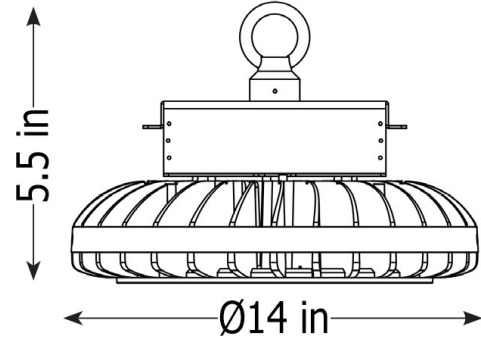

## UHB2-220-CW

## UHB2-220-NW

### LED UFO HIGH BAY FIXTURES

Ideal for general site lighting, alleys, loading docks, doorway, pathway and parking areas.

**ELECTRICAL SPECIFICATIONS:**

- Voltage: 120-277VAC 50/60Hz
- Wattage: 220W
- Other wattages: 100W, 150W, 300W, 360W
- Power factor: >0.9
- Efficacy: 120LM/W

**HOUSING SPECIFICATIONS:**

- ACD12 aluminum heat sink, SUS black plate
- Outdoor powder coat finish (Black)
- Operating temperature: -4°F ~ 104°F
- Lifespan: 50000 Hrs.
- IP rating: IP65, Wet Locations
- High-transmittance, anti-UV and fire resistant PC lens

**CERTIFICATIONS: UL, DLC**



| MODEL       | WATTS | VOLTAGE     | LUMENS   | COLOR TEMP |
|-------------|-------|-------------|----------|------------|
| UHB2-220-CW | 220W  | 120~277V AC | 27000 LM | 5000K      |
| UHB2-220-NW | 220W  | 120~277V AC | 27000 LM | 4000K      |

**LIGHTING SPECIFICATIONS:**

- LED type/brand: SMD 3030,
- Total lumens: 27000LM
- Color temperature: 4000K / 5000K
- Color rendering index: >80
- Beam angle: 90°

**WARRANTY: 5 years**



## UHB2-220-CW UHB2-220-NW

### LED UFO HIGH BAY FIXTURES

| MODEL       | WATTS | VOLTAGE     | LUMENS   | COLOR TEMP |
|-------------|-------|-------------|----------|------------|
| UHB2-220-CW | 220W  | 120~277V AC | 27000 LM | 5000K      |
| UHB2-220-NW | 220W  | 120~277V AC | 27000 LM | 4000K      |

### CERTIFICATIONS: UL, DLC



### PHOTOMETRICS:

#### Spectral Power Distribution & Chromaticity Diagram

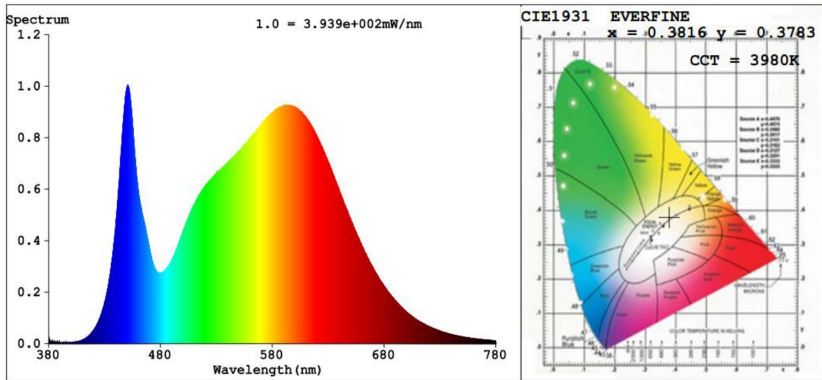

#### ILLUMINANCE AT A DISTANCE

|         | Center Beam fc | Beam Width |          |
|---------|----------------|------------|----------|
| 17.0ft  | 43.2 fc        | 35.8 ft    | 35.5 ft  |
| 34.0ft  | 10.8 fc        | 71.5 ft    | 70.9 ft  |
| 51.0ft  | 4.8 fc         | 107.3 ft   | 106.4 ft |
| 68.0ft  | 2.7 fc         | 143.1 ft   | 141.8 ft |
| 85.0ft  | 1.7 fc         | 178.8 ft   | 177.3 ft |
| 102.0ft | 1.2 fc         | 214.6 ft   | 212.7 ft |

■ Vert. Spread: 92.9°  
■ Horiz. Spread: 92.4°

