

JOB NAME: _____

DATE: _____

TYPE: _____



DIMENSIONS:

21.85"(L) x 12.29"(W) x 4.85"(H)

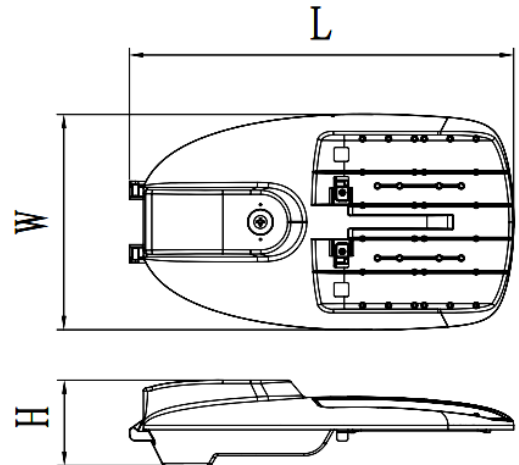

STL2-200W-50K-480V

**LED STREET/ROADWAY LIGHTS WITH
 w/NEMA TWIST-LOCK PHOTOCELL SOCKET**

Ideal for general site lighting, street, roadway, alleys, loading docks, doorway, pathway and parking areas.

ELECTRICAL SPECIFICATIONS:

- Voltage: 480V
- Wattage: 200W
- Power factor: >0.90
- Efficacy: 135LM/W

HOUSING SPECIFICATIONS:

- Die-Cast Aluminum
- Powder Coat Finish (Light Grey)
- w/NEMA Twist-lock photocell socket, shorting cap incl.
- 6KV lightning surge protection
- Operating temperature: -40°F to 104°F
- Lifespan: 70,000 hr.
- IP Rating: IP65

CERTIFICATIONS: UL, DLC



MODEL	WATTS	VOLTAGE	LUMENS	COLOR TEMP
STL2-200W-50K-480V	200W	480V	27000LM	5000K

OPTIONAL ACCESSORY:



MODEL	DESCRIPTION
PC-TWIST-480V	1800W Tungsten twist lock photocell

LIGHTING SPECIFICATIONS:

- Lens: Optical TYPE III Lens
- Total lumens: 27000LM
- Color temperature: 5000K
- Color rendering index: >70

WARRANTY: 7 years



STL2-200W-50K-480V

LED STREET/ROADWAY LIGHTS WITH
 w/NEMA TWIST-LOCK PHOTOCELL SOCKET

MODEL	WATTS	VOLTAGE	LUMENS	COLOR TEMP
STL2-200W-50K	200W	480 V	27000LM	5000K

PHOTOMETRY:

