

LRP-HL SERIES Commercial Lighting

LRP-HL-2X2-MCTP PREMIUM HIGH-LUMEN RETROFIT FLAT PANEL

MCTP Multi Color Temperature &
Multi Power/Wattage (Selectable)



Elevate your space with Westgate's Premium High-Lumen Retrofit Flat Panel. This cutting-edge LED fixture delivers exceptional brightness and energy efficiency, seamlessly replacing traditional fluorescent troffers. With advanced LED technology and uniform light distribution, it's perfect for commercial, retail, and educational settings. Easy to install and designed for longevity, our retrofit flat panel offers superior illumination and a higher ROI. Experience the future of lighting with Westgate.

Customer Name: _____

Project Name: _____

Note: _____ | Type: _____

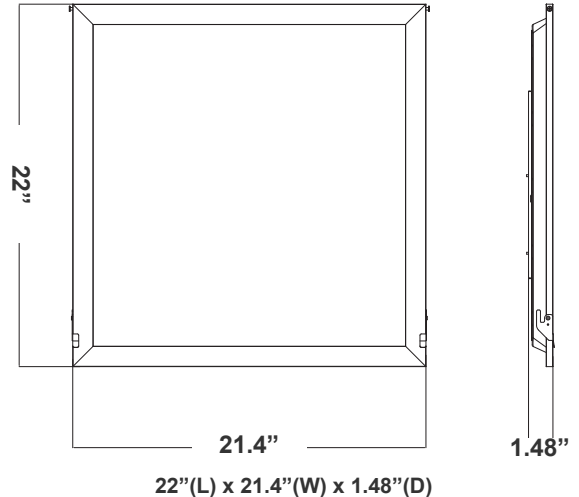

Features

- 5-Year Warranty
- White Finish
- Rated Life: 50,000 Hours
- Lens: Polycarbonate
- Multi CCT & Power (Selectable Switch On Back Of Fixture)

Technical Specifications

Electrical:

- Voltage: 120-277VAC 50/60Hz
- Wattage: 16W/20W/24W
- Power Factor: >0.9
- Efficacy: 125 LPW

Mechanical:

- White Finish
- Galvanized Steel Construction
- Integrated Securement Tabs for Securement to Existing Troffer Housing.
- Minimum Depth of only 3" Necessary To Allow Proper Clearance And Installation
- Retrofit Kit Is Powder Coated After Fabrication With High Quality, Durable Finish To Ensure No Unfinished Edges And Avoid Future Potential Of Corrosion.
- Components Fit Together Easily Without The Need For tools during installation. in addition the light module Can Be Removed From Below The Ceiling For Continent Maintenance And Upgrades
- Operating Temperature: -4°F ~ 113°F
- 5-Year Warranty

Lighting:

- Multi CCT & Power (Selectable Switch On Back Of Fixture)
- Dimmable: 0~10V Dimming
- LED Type: SMD 2835
- Total Lumens: 3000LM
- Color Rendering Index: CRI ≥ 80
- Color Temperatures: 3500K/ 4000K/ 5000K
- Rated Life: 50,000 Hours

Applications:

- Elevate your lighting experience with the Westgate LED Retrofit Troffer – a perfect blend of innovation, efficiency, and reliability. Designed to seamlessly fit into existing troffer installations, this retrofit solution transforms traditional lighting systems into energy-efficient, cost-effective lighting with minimal effort.

Other Models:

- 40W | 5000LM | LRP-HL-2X4-MCTP



Photometrics: LRP-HL-2X2-MCTP

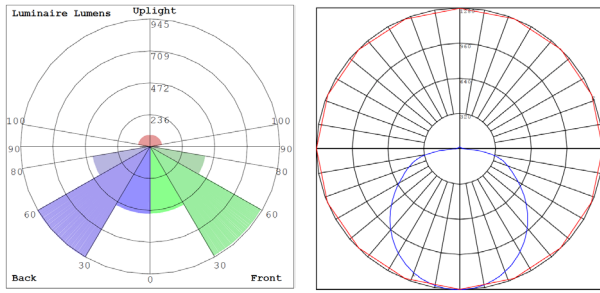

BUG Rating: B1-U3-G1

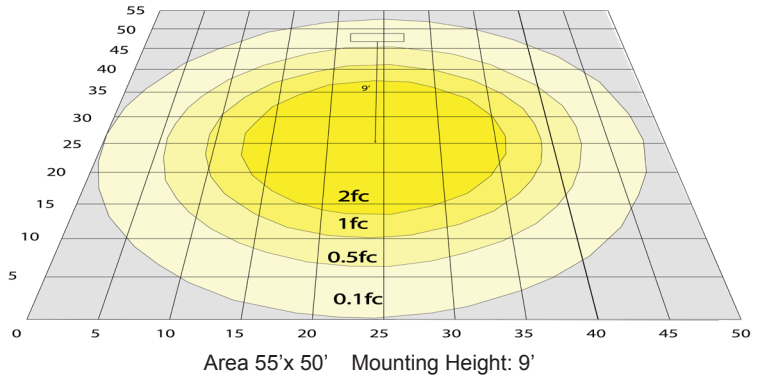

Other Views:



Side View

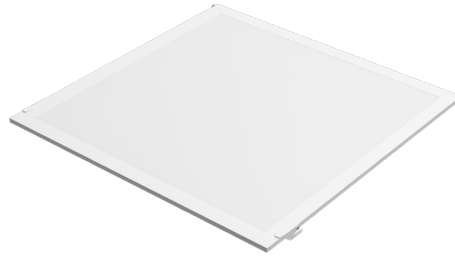

Front View



Back View

Performance Table: LRP-HL-2X2-MCTP

MODEL NO.	Wattage	Voltage	Lumens	Color Temp.	BUG Rating	LPW
LRP-HL-2X2-MCTP	16W 20W 24W	120~277V	2000LM 2500LM 3000LM	3500K 4000K 5000K	B1-U3-G1	125

Sample Ordering

Model High Lumen Size Color Temp.

LRP - HL - 2X2 - MCTP

Factory-Installed Options:

Blank = No Option For Accessories
 OPT-EM-LTR = EMERGENCY BACKUP BATTERY MOUNTED ON TOP OF FIXTURE
 OPT-SEN-2MDR-36 = PROGRAMMABLE MICROWAVE BI-LEVEL SENSOR

Packaging Info:

	QTY	UOM	L (IN)	W (IN)	D (IN)	Weight (LBS)
Master Carton	2	Case	5.20	23.82	24.57	14.90

NO PARTIAL. MUST BUY IN MASTER PKG. QTY.

FACTORY-INSTALLED OPTIONS:



OPT-EM-LTR



OPT-SEN-2MDR-36

