

DIMENSIONS:

4.2"(H) x 3.2"(L) x 1.8"(W)

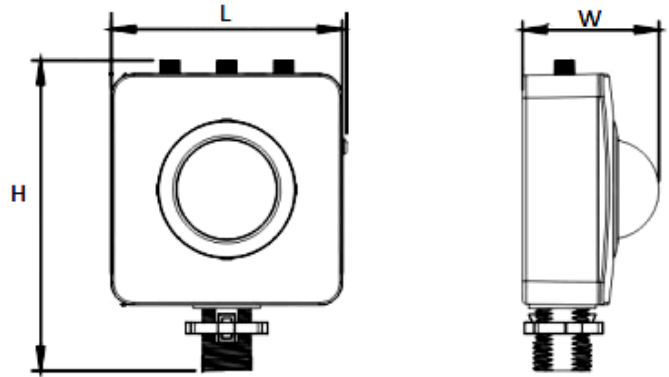

LLHB-OC1

OCCUPANCY SENSORS

Ideal for offices, motel, bank, warehouses, gas-station, supermarket, mall.

ELECTRICAL SPECIFICATIONS:

- Max Load: 800W/1300W
- Voltage: 120~277VAC 50/60Hz
- Motor load: 1/4HP
- Mini load: none
- Standby power: working 0.45W (static 0.1W)

HOUSING SPECIFICATIONS:

- PIR High bay Motion Sensor with manual setting
- Installation Height: 8-50ft
- Operating temperature: 14°F ~ 104°F
- Outdoor Motion Sensor

CERTIFICATIONS:

MODEL	MAX LOAD	VOLTAGE	DETECTION ANGLE
LLHB-OC1	80W/1300W	120~277VAC	360°

TECHNICAL SPECIFICATIONS:

- Detection Angle: 360°
- Maximum Detection Area: 50'ft. Height & Diameter 60'ft.
- Sensor: Pir & Microphonic
- Light-control: 10LUX~2000LUX (Adjustable)
- Time Setting: 10sec-30min (Adjustable)
- Detection motion speed: 2~5ft/s



LLHB-0C1

OCCUPANCY SENSORS

DETECTION RANG:

MODEL	MAX LOAD	VOLTAGE	DETECTION ANGLE
LLHB-0C1	80W/1300W	120~277VAC	360°

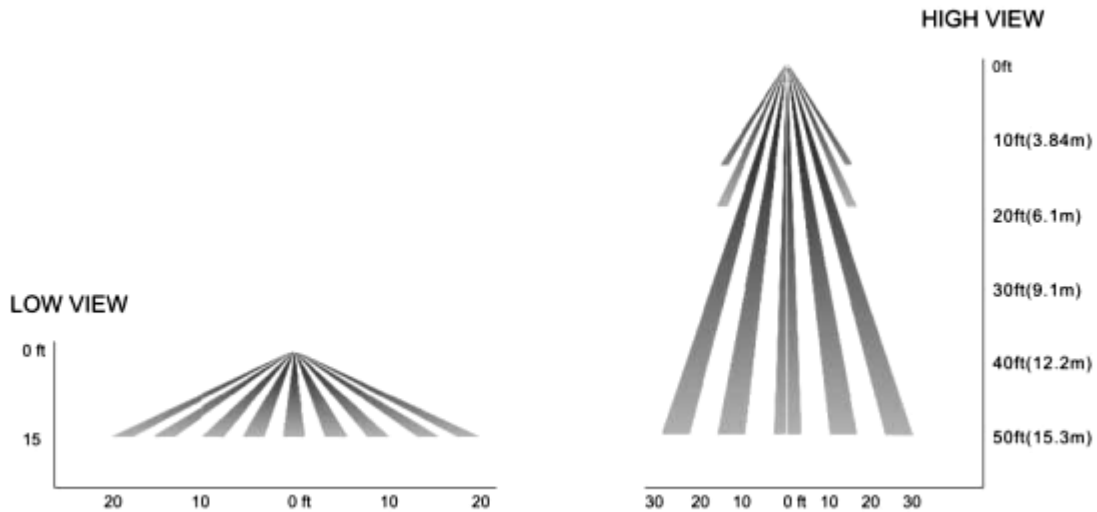

WIRING DIAGRAM:

120-347V - Wiring Diagram

