

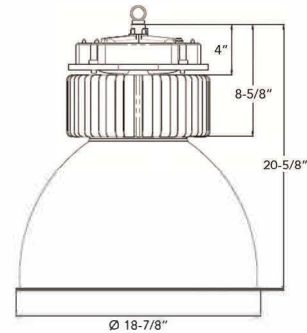

DIMENSION:



LHB-100-CW LHB-100-NW

LED High Bay Lamp

High Bay light is designed for illumination of industrial locations. It uses the latest in solid state lighting technology for long life, low maintenance, and high efficiency.

The unique optical design focuses light downward to where it is needed, giving improved efficiency over a conventional HID luminaire.

MODEL NO	WATTAGE	LUMENS	VOLTAGE	COLOR TEMP	REFLECTOR
LHB-100-CW	100W	11800	120/277V AC	CW 5000K	16" PC
LHB-100-NW	100W	11500	120/277V AC	NW 4000K	16" PC

ELECTRICAL SPECIFICATIONS:

- Voltage: 100-277V AC
- Wattage: 100W
- Other wattages available: 50W, 150W, 200W
- Power factor: 95% +

LIGHTING SPECIFICATIONS:

- LED: Philips
- Color temperature: 4000K & 5000K
- CRI: 80
- L70 design life (50,000)

HOUSING SPECIFICATIONS:

- Reflector: 16inch PC
- Ambient Temp: -20~+40C°
- Operating Temperature: -4F° to 140F°
- IP65
- Housing: Die-cast aluminum housing with ribbed polycarbonate reflector

CERTIFICATIONS:

- UL listed, DLC

WARRANTY:

- Five-year warranty

