

LDL SERIES INDUSTRIAL LIGHTS

LDL-S-50W-60K-B40R
LOADING DOCK LIGHTS

WESTGATE
THE FUTURE IS HERE...AND IT'S QUITE BRIGHT!



Customer Name: _____

Project Name: _____

Note: _____

Type: _____

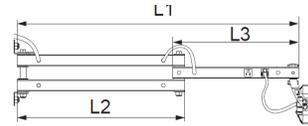

	L1	L2	L3
Bracket B2	1067.5mm/42.02"	600mm/23.62"	450mm/17.72"

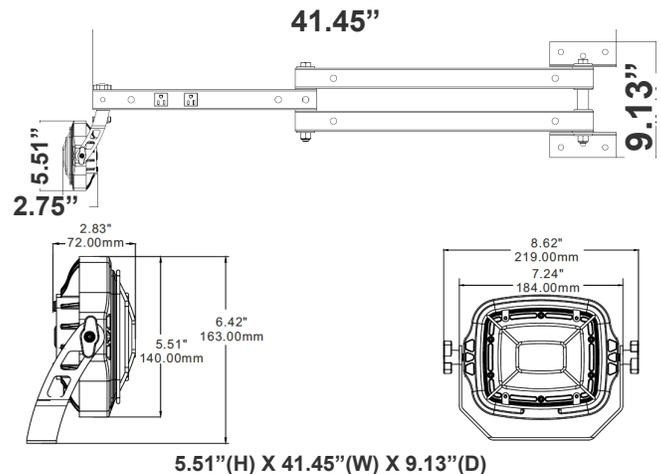

Westgate's LDL LED Loading Dock Lights - the ultimate solution for brightening loading docks in warehouses, distribution centers, manufacturing facilities, retail stores, transportation hubs, commercial buildings, logistics centers, and industrial parks. Our lights ensure safe and efficient movement of goods, enhance visibility for loading and unloading trucks, streamline material handling processes, and support smooth deliveries and maintenance operations. With Westgate, illuminate your loading docks and optimize logistics operations with ease.

Features

- 5-Year Warranty
- Built-in switch to control on-off
- Lifespan: 50000 Hrs

Technical Specifications

Electrical:

- Voltage: 120V/60Hz
- Wattage: 50W
- Input: .85A/ Output: 36-66V DC
- LED Wattage: >0.95
- THD: <20%
- Efficacy: 140 LM/W

Mechanical:

- 5' 18/3 AWG Power Cord
- Adjustable Screw On The Lamp, Adjust Lamp's Angle by Hand
- Two 3-Prong Receptacle on The Middle Arm
- Compact Design Utilizes Aluminum Housing For Cooling System
- Eliminates light bulb replacement and/or clean-up
- Increase Energy Savings And Shorten Payback Period
- Operating Temperature: -4 F° to 114 F°
- IP65, Suitable for Wet Location

Lighting:

- EPISTAR LED
- Total Lumens: 7000LM
- Color Temperature: 6000K
- Lifespan: 50000 Hrs.

360° Rotatable Lamp Head



Adjust to fit any angle you needed

This perfectly folds back and takes up little space when not in use

Other Models:

- 30W | 3300LM | LDL-R-30W-60K-A40
- 60W | 7000LM | LDL-R-60W-60K-A40



Phone: (877) 805-2252 | Fax: (877) 805-2252
www.westgatemfg.com



WG-04012024

Applications:

- Warehouses: Illuminate loading docks within warehouses to ensure safe and efficient movement of goods, even during nighttime or low-light conditions.
- Distribution Centers: Enhance visibility for loading and unloading trucks at distribution centers, improving productivity and reducing the risk of accidents.
- Manufacturing Facilities: Illuminate loading bays and docks in manufacturing facilities to streamline material handling processes and improve workflow efficiency.
- Retail Stores: Provide bright and clear lighting for loading docks at retail stores, ensuring smooth deliveries and replenishment of inventory.
- Transportation Hubs: Illuminate loading areas at airports, train stations, and bus terminals to facilitate the safe and timely loading and unloading of cargo and passenger luggage.
- Commercial Buildings: Ensure well-lit loading docks at commercial properties such as office buildings, shopping malls, and hospitals to support deliveries and maintenance operations.
- Logistics Centers: Illuminate loading docks at logistics centers and fulfillment warehouses to optimize logistics operations and meet stringent delivery schedules.
- Industrial Parks: Enhance safety and productivity in industrial parks by illuminating loading docks for tenants and logistics providers.

Other Views:



Side View



Front View



Side View

Performance Table: LDL-S-50W-60K-B40R

MODEL NO.	WATTS	Lumens	Color Temp.	LPW
LDL-S-50W-60K-B40R	50W	7000LM	6000K	140

Sample Ordering

Model	Shape	Watt	Color Temp.	Style
LDL	S	50	60K	B40R



Details:

Note: Fan Not Included

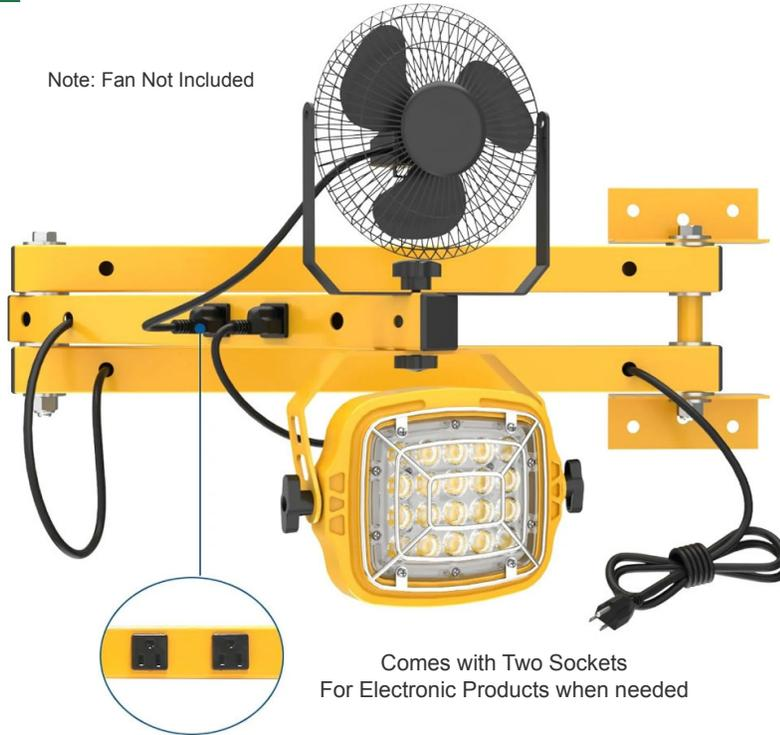

Comes with Two Sockets
For Electronic Products when needed

Led Dock Lights

Adopt Solid & Sturdy design ensure more than 50000 hours life time

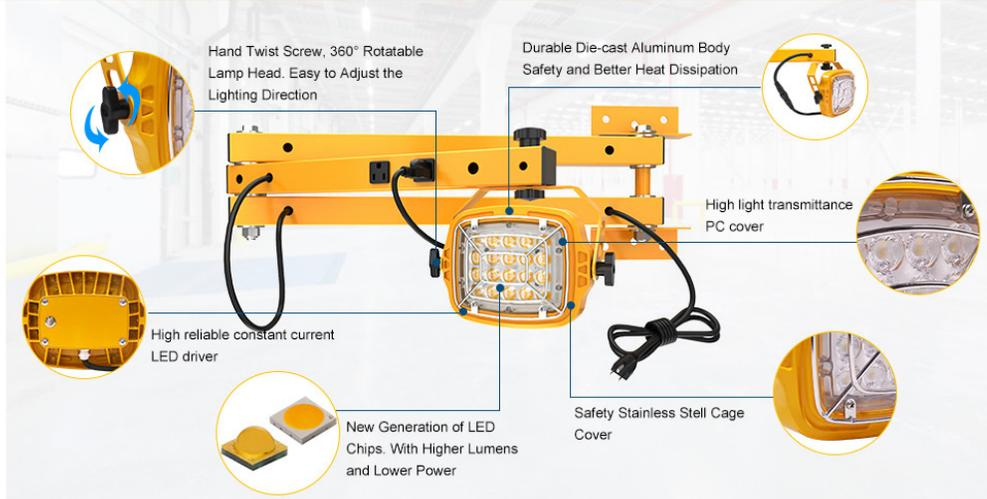

2 sockets
2 sockets --One more choices- electric fan.



IP65 Waterproof
LED Loading dock light is IP65 waterproof rated, suitable for both wet and damp locations.



Anti-corrosion stainless steel cage
Anti-corrosion stainless steel cage with good impact resistance



2 Arms
Heavy-Duty industrial grade designed 2 Arms --Withstand weight of 20kg.

