



EVC-C-40A-AC-9.6KW-J1772

Installation and Operation Manual

Version A1

Copyright Information

No part of this manual may be reproduced, stored in a retrieval system or transmitted, in any form or by any means, electronic, mechanical, photocopying, recording, or otherwise without the prior written permission of WESTGATE.

Disclaimer of Warranties and Limitation of Liabilities

All information, specifications and illustrations in this manual are based on the latest information available at the time of printing.

WESTGATE reserves the right to make changes at any time without notice. While information of this manual has been carefully checked for accuracy, no guarantee is given for the completeness and correctness of the contents, including but not limited to the product specifications, functions, and illustrations.

WESTGATE will not be liable for any direct, special, incidental, indirect damages or any economic consequential damages (including the loss of profits).

For Services and Support (Mon - Fri / 8:00 am - 5:00 pm)

Web: www.westgatemfg.com

Tel: 1-323-826-9490

Email: Customerservice@westgatemfg.com

Address: 2462 E 28th Street, Vernon, CA 90058, USA

IMPORTANT SAFETY INSTRUCTIONS



WARNING

When using electric products, basic precautions should always be followed, including the following.

- a) Read all the instructions before using this product.
- b) This device should be supervised when used around children.
- c) Do not put fingers into the electric vehicle connector.
- d) Do not use this product if the flexible power cord or EV cable is frayed, has broken insulation, or any other signs of damage.
- e) Do not use this product if the enclosure or the EV connector is broken, cracked, open, or shows any other indication of damage.
- f) **WARNING**

GROUNDING INSTRUCTIONS

This product must be connected to a grounded, metal, permanent wiring system, or an equipment-grounding conductor must be run with the circuit conductors and connected to the equipment grounding terminal or lead on the product.

- g) Risk of electric shock.



SAVE THESE INSTRUCTIONS

CONCERNANT LA SÉCURITÉ CONSERVER CES



AVERTISSEMENT

Lors de l'utilisation de produits électriques, les précautions de base doivent toujours être suivies, y compris les suivantes.

- a) Lisez toutes les instructions avant d'utiliser ce produit.
- b) Ce dispositif devrait être supervisé lorsqu'il est utilisé autour des enfants.
- c) Ne mettez pas les doigts dans le connecteur de véhicule électrique.
- d) N'employez pas ce produit si le cordon d'alimentation flexible ou le câble d'ev est effiloché, a l'isolation cassée, ou tout autre signe de dommages.
- e) N'employez pas ce produit si le boîtier ou le connecteur EV est cassé, fissuré, ouvert, ou montre n'importe quelle autre indication de dommages.

f) **AVERTISSEMENT**

INSTRUCTIONS de mise à la terre

Ce produit doit être relié à un système de câblage permanent mis à la terre, en métal, ou un conducteur de mise à la terre de l'équipement doit être exécuté avec les conducteurs de circuit et connecté à la borne de mise à la terre de l'équipement ou au fil sur le produit.

- g) Risque de choc électrique.



CONSERVER CES INSTRUCTIONS

For FCC application

This device complies with Part 15 of the FCC Rules. Operation is subject to the following two conditions: (1) this device may not cause harmful interference, and (2) this device must accept any interference received, including interference that may cause undesired operation.

Changes or modifications not expressly approved by the party responsible for compliance could void the user's authority to operate the equipment.

This equipment has been tested and found to comply with the limits for a Class B digital device, pursuant to part 15 of the FCC Rules. These limits are designed to provide reasonable protection against harmful interference in a residential installation. This equipment generates uses and can radiate radio frequency energy and, if not installed and used in accordance with the instructions, may cause harmful interference to radio communications. However, there is no guarantee that interference will not occur in a particular installation. If this equipment does cause harmful interference to radio or television reception, which can be determined by turning the equipment off and on, the user is encouraged to try to correct the interference by one or more of the following measures:

- Reorient or relocate the receiving antenna.
- Increase the separation between the equipment and receiver.
- Connect the equipment into an outlet on a circuit different from that to which the receiver is connected.
- Consult the dealer or an experienced radio/TV technician for help.

Content

1	Using This Manual.....	8
1.2	Revision History.....	9
2	General Introduction.....	10
2.1	Product Overview.....	11
2.2	Product Dimensions.....	11
2.3	In the Box.....	12
2.4	Recommended Tools.....	13
3	Installation.....	14
3.1	Electrical Design.....	14
3.1.1	Upstream Wiring.....	14
3.1.2	Grounding Requirements.....	15
3.2	Preparing for Installation.....	16
3.2.1	Installation Requirements.....	16
3.2.2	Cable Entry Options.....	17
3.3	Installing the Charger.....	17
3.4	Cable Connection.....	21
4	Operation.....	22
4.1	Powering On.....	22
4.2	One-stop Commissioning.....	22
4.3	Starting Charging.....	22
4.4	Stopping Charging.....	23
4.5	LED Descriptions.....	23
5	Troubleshooting.....	25
6	Specifications.....	26

1 Using This Manual

This manual describes the installation and use of the charger. Prior to installation, read through this manual to get familiar with the instructions of this charger to ensure a successful installation and smooth operations.



NOTICE

Illustrations used in this manual are only examples; the actual products or screens may differ.

1.1 Signal Word



DANGER

Indicates an imminently hazardous situation with a high risk level which, if the danger is not avoided, will cause death or serious injury.



WARNING

Indicates a potentially hazardous situation with moderate risk level which, if the warning is not obeyed, can cause death or serious injury.



CAUTION

Indicates a potentially hazardous situation with a medium risk level which, if the caution is not obeyed, may cause minor or moderate injury or damage to the equipment.



NOTICE

Provides helpful information such as additional explanations, tips, and comments.

1.2 Revision History

Version	Date	Descriptions
Version A0	2025.06	Initial version
Version A1	2025.07	

2 General Introduction

This charger is designed to charge plug-in hybrid electric vehicles (PHEVs) or fully electric vehicles (EVs). It will provide you with reliable, intelligent, and scalable charging solutions.

This manual will instruct you how to install and use this charger.

Intended Use

This charger is intended for the AC charging of EVs. It is intended for both indoor and outdoor use.



DANGER

If you use the charger in any way other than described in this manual or other related documents, possible death, injury and damage to property can occur.

Use the charger only as intended.

2.1 Product Overview

- ① LED Indicator
- ② Emergency Stop Button
- ③ AC Power Inlet
- ④ Charging Cable Inlet

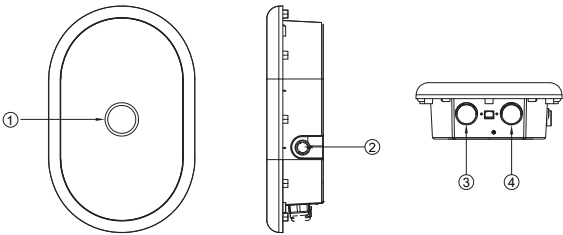



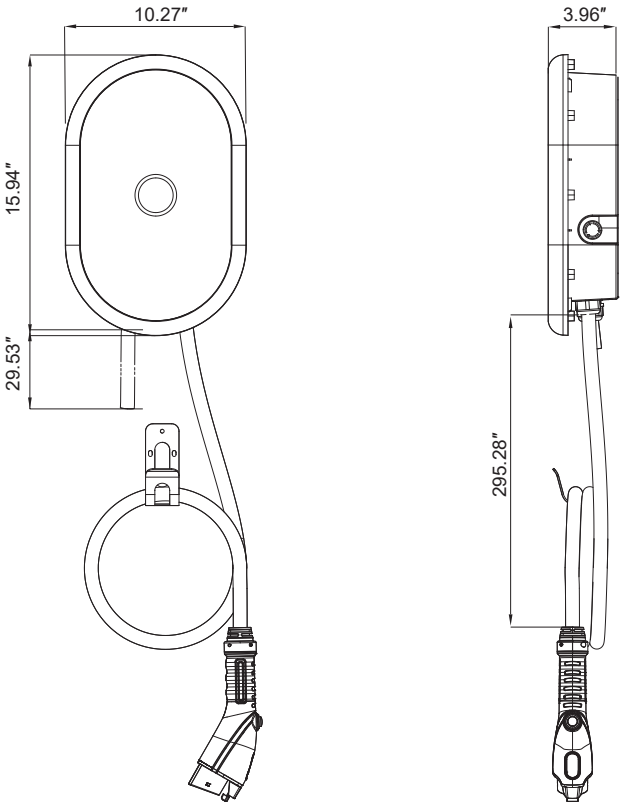



2.2 Product Dimensions

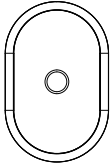
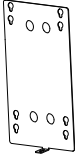









2.3 In the Box

Ensure that all parts are delivered according to the order. Check the packages for the following parts.

<p>Charger 1 PC</p>		<p>Mounting Bracket 1 PC</p>		<p>Hook 1 PC</p>	
<p>Wall Anchor φ8x40mm 8 PCS</p>		<p>Sheet Metal Screw ST5x40mm 8 PCS</p>		<p>Screw M4x10 1 PC</p>	
<p>User manual 1 PC</p>					

2.4 Recommended Tools

Tape Measure		Pencil		Wire Stripper	
Drill Bit Φ 5/16" (8 mm)		Drill Bit Φ 9/16" (14 mm)		Power Drill	
Multimeter		Phillips Bit PH2		Phillips Screwdriver	



NOTE

The tools mentioned above are not included in the package. Ensure they are readily available prior to installation.

3 Installation

3.1 Electrical Design

3.1.1 Upstream Wiring

Chargers are considered continuous load devices (EVs draw maximum load for long durations); therefore, electrical branch circuits must be sized at 125% of the load for North American installations, in accordance with National Electric Code (NEC) requirements. (For other regions, refer to local code.) This means that for a maximum 40 A load at 120/208/240 V output to an electric vehicle, 50A breaker is required.

Wiring must be sized in accordance with NEC requirements for continuous load devices. Typically, 8 AWG (8.37 mm²) insulated electrical wire is used, depending upon the rating of the circuit and the distance between the electrical panel and the charger.

240 VAC Panel

- 1. Main Breaker
- 2. PE Bus
- 3. L1
- 4. L2
- 5. Local Service or Sub Panel

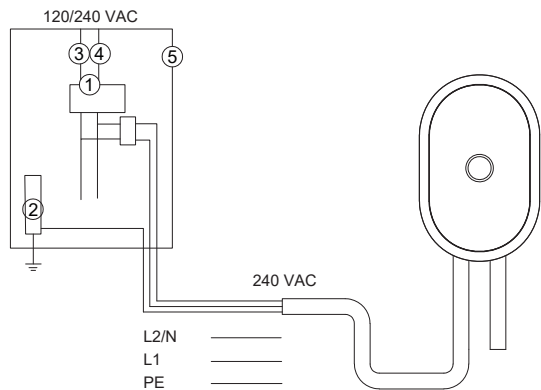

208 VAC Panel

1. Main Breaker
2. PE Bus
3. L1
4. L2
5. L3
6. Local Service or Sub Panel

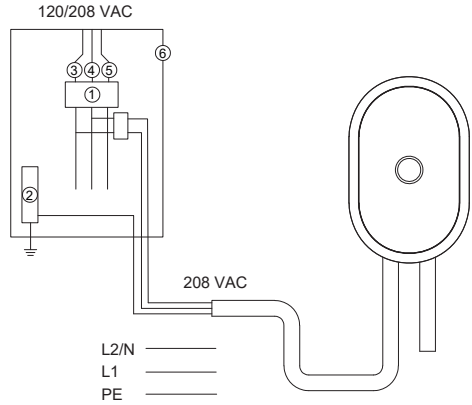

3.1.2 Grounding Requirements

The charger must be connected to a grounded, metal, and permanent wiring system. An equipment- grounding conductor must be run with circuit conductors and connected to an equipment-grounding terminal or lead on the charger.

A grounding conductor, compliant with applicable codes, must be grounded at the service equipment or, when supplied by a separate system, at the supply transformer.

3.2 Preparing for Installation

3.2.1 Installation Requirements

- Install the charger on a flat and vertical surface capable of supporting its weight (e.g., a finished wall or pedestal). The maximum weight of the charger is approximately 17.2 lbs. (7.8 kg).
- Install the charger in a location that allows the charging cable to remain within its bending tolerance.
- Position the charger in a location where it is not vulnerable to being damaged.
- Ensure the electrical panel supports a 240 V dedicated circuit with a new, dedicated, and non-GFCI two-pole circuit breaker, in accordance with local codes and ordinances.
- The recommended installation height for the charger is between 33.5 and 45.3 inches (850 to 1150 mm). The minimum outdoor installation height is 24 inches (600 mm) and that of indoor is 18 inches (450 mm). For ADA accessibility, mount the charger at a height of 27.6 – 33.5 inches (700–850mm).



CAUTION

A supplement surge protection breaker must be installed at the service panel if the installation area experiences frequent thunderstorms.

3.2.2 Cable Entry Options

The recommended cable entry options are described below. The preparation work varies depending on the entry options.

Cable Entry Option	A: Power Cable <ul style="list-style-type: none">▪ Line/neutral: 8 AWG (8.37 mm²)▪ PE: minimum 8 AWG (8.37 mm²).▪ Copper wire only.
---------------------------	--

3.3 Installing the Charger



DANGER

Risk of shock. Turn off the power to the outlet at the circuit breaker until the installation is completed.



NOTICE

It is suggested that the configuration be finished on the WestGate Operation and Maintenance Platform before the installer installs the chargers. Refer to 4.2 for more details.

STEP 1

1. Place the Mounting Bracket against the wall at a height of 33.5 ~ 45.3 inches (850 ~ 1150 mm).
2. Mark the four mounting holes using a pencil and remove the Mounting Bracket temporarily.

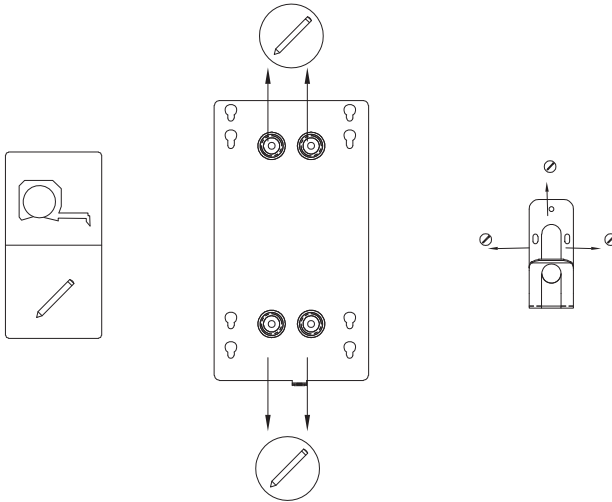

STEP 2

1. Drill Anchor Holes

▪ Tool Preparation:

- 1) Use a Hammer Drill with an 8mm Masonry Bit to drill holes at marked wall positions.

▪ Operational Specifications:

- 1) Maintain the drill bit perpendicular to the wall surface; strictly control drilling depth at 50mm (2 inches) (mark depth on the bit with tape).
- 2) After drilling, clear debris from holes using compressed air or a brush to ensure intact hole walls.

2. Install wall anchor

- 1) Tap anchors into holes with a rubber mallet until flush with the wall surface (avoid tilting to prevent wall cracking).
- 2) Verify anchor stability: manually test for looseness; if unstable, replace with a larger-size anchor.

3. Secure mounting bracket.

- 1) Align bracket holes with anchors and press firmly against the wall.
- 2) Fit an electric drill with a PH2 Phillips Bit and set to Low-Speed High-Torque Mode (500–800 RPM recommended).

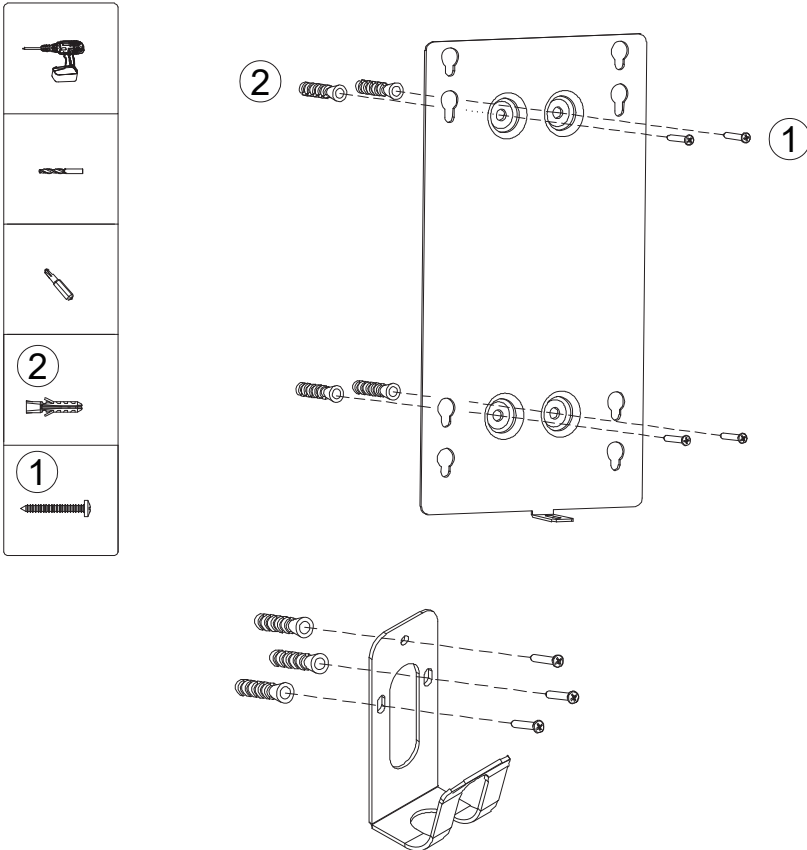

STEP 3

1. Align Alignment Bosses with Keyhole Slots.
2. Position the four alignment bosses on the charger's back precisely into the keyhole slots on the mounting plate.
3. Tighten Screws, Use a cross-head screwdriver or electric drill (low-speed mode). Tighten fixing screws in diagonal sequence on both sides of the mounting plate.

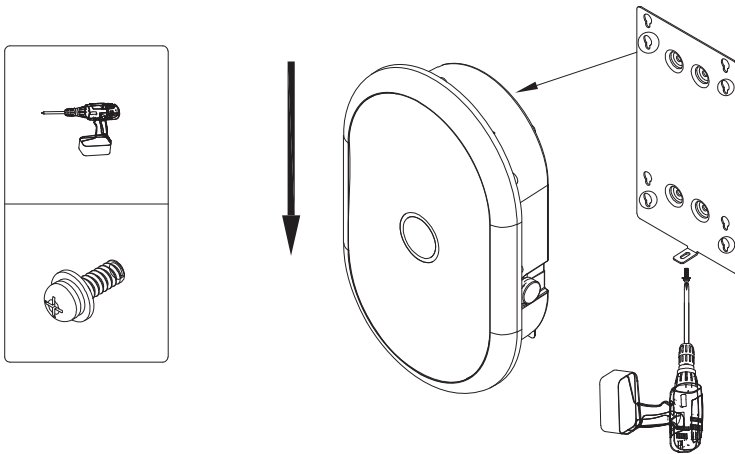

3.4 Cable Connection



CAUTION

For the power cable, use copper conductors with the wire size being 8 AWG (8.37 mm²).

Prepare the conduits and conduit fittings (1-inch recommended) and route them into the charger according to the cable entry.

The AC input cable of the AC charger is divided into three signals (L1, L2/N, PE), and these three signals are connected to the corresponding L1, L2/N, PE positions in the user's junction box or distribution box.

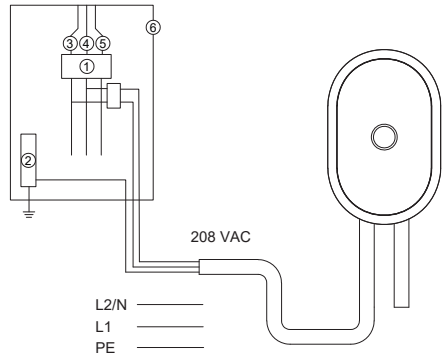

4 Operation

4.1 Powering On

Once all electrical connections have been safely made, switch on the power to the circuit from the circuit breaker and wait for the power supply to come on.

There will be a series of self-checks. Make sure that the charger works correctly and safely.



WARNING

Be careful when working with electricity.

4.2 One-stop Commissioning

The commissioning of the chargers will be completed by the owner or the site operator, the installer and the commissioning personnel. The steps are as follows.

- The installer installs the chargers and checks the installation.

4.3 Starting Charging

1. Plug the charging connector to the EV.
2. The indicator light changes from green light always on to breathing light that goes from dim to bright.



NOTICE

Ensure that the EV is charging. If charging issues persist, try reconnecting the connector or contact technical support.

4.4 Stopping Charging

1. The vehicle stops charging, the indicator light changes from dim to bright breathing Light to bright to dim breathing light. After waiting for more than ten seconds, the indicator light changed to 1 second on, 1 second off. Pull out the charging cable to complete charging.
2. Unplug the charging connector from the EV.

NOTE: In case of emergency, please stop charging immediately, you can press the emergency stop button which will stop charging immediately when pressed. If you need to resume, turn the button in the direction of the arrow on the emergency stop button.



NOTICE

When the vehicle is fully charged, the charger will automatically disconnect the power supply.

4.5 LED Descriptions

The Charger Indicator Description

Status Type	Light Behavior	Condition Details
Charging	Green light breathing	Steady pulsing effect
Available	Green light always on	Ready for charging
Preparing	Green light flashes slowly: · 2s on / 2s off · 1s on / 1s off	Awaiting charging initiation
Finishing	Green light breathing gradually dimming, repeating	Post-charge cooldown state

Fault Indicator Description

Error Type	Light Behavior	Diagnosis
Electric Leakage Fault	Red light: 2s on / 2s off	Detected an electrical leakage fault
Grounding Fault	Red light: 4s on / 4s off	Abnormal grounding resistance
Meter Communication Error	Red light: 6s on/ 6s off	Power meter communication failure
Critical Electrical Fault	Red light always on	<ul style="list-style-type: none"> ▪ Over-voltage ▪ Under-voltage ▪ Over-current

5 Troubleshooting

Item	Problems	Solutions
1	Over-voltage	Use the multimeter to check whether the voltage on the power input is too high. If the result is greater than or equal to 276 V, 115 % of the rated voltage (240 V), contact local power grid company.
2	Under-voltage	Use the multimeter to check whether the voltage on the power input is not sufficient. If the result is less than or equal to 166.4 V, 80 % of the rated voltage (208 V), contact local power grid company.
3	Ground fault	Ensure the charger is grounded correctly.
4	Power failure	Ensure the switch to the circuit breaker is on.
5	Residual current detected	Unplug the vehicle and plug in again. If the problem persists, contact customer support.

6 Specifications

Item	Description
Input/Output Power Rating and Current	9.6kW (240V AC 40A)
Input/Output Voltage	208/240V AC 50/60Hz
Input Power Connections	L1, L2/N, input power connections and Earth
Input Cord	Hardwired
Connector Type	SAE J1772
Charging Cable Length	24.61ft. (7.5 m)
Protection	Overcurrent, overvoltage, undervoltage, integrated surge protection
Mounting	Wall-mounted
Enclosure Ratings	NEMA 4, IK08
Operating Altitude	9842 ft. (3000 m)
Operating Temperature Range	-22 to 122 °F (-30 to + 50 °C)
Storage Temperature Range	-40 to 158 °F (-40 to + 70 °C)
Dimensions (H x W x D)	15.94" x 10.27" x 3.96"
Package Dimensions (H x W x D)	27.95" x 12.99" x 7.87"
Weight	19.84lb
ETL Safety Standards	UL 2594: 2022 Ed.3 Clause, CSA C22.2#280:2022 Ed.3, UL 2231-2:2012 Ed.2+R:15Dec2020 Clause, UL 50E: 2020 Ed.3 Clause, UL 991:2004 Ed.3+R:09Jun2010:Clause, UL 1998:2013 Ed.3+R:24Sep2018 Clause.
FCC Standrards	FCC part 15 B
Energy Standards	ENERGY STAR ® Program Requirements for Electric Vehicle Supply Equipment (EVSE) Version 1.1 and 1.2
Warranty	3 years: the charger body, backplate and all internal components 1 year: charging cable and connector

WESTGATE
THE FUTURE IS HERE... AND IT'S QUITE BRIGHT!

www.westgatemfg.com