

LED Outdoor Fixture Installation

PLEASE READ THESE INSTRUCTIONS CAREFULLY AND SAVE THEM, AS YOU MAY NEED THEM AT A LATER DATE.

- **RISK OF ELECTRICAL SHOCK:** TURN MAIN SWITCH AND CIRCUIT BREAKER TO "OFF" POSITION BEFORE SERVICING OR RELAMPING.
- ALL ELECTRICAL CONNECTIONS MUST BE IN ACCORDANCE WITH LOCAL CODES, ORDINANCES AND NATIONAL ELECTRICAL CODE. IF YOU ARE UNFAMILIAR WITH PROPER ELECTRICAL WIRING OR CONNECTIONS, SECURE THE SERVICES OF A QUALIFIED LICENSED ELECTRICIAN.
- PROPER GROUNDING OF THE FIXTURE IS ESSENTIAL FOR PROTECTION FROM SHOCK, CORRECT OPERATION OF THE ELECTRONIC DRIVER AND THE ELIMINATION OF THE ELECTRICAL INTERFERENCE.

PREPARATION:

1. Tools and materials needed: screw driver, pliers, wire nuts, electrical tape.
2. To help prevent the possibility of electrical shock, the use of rubber sole shoes is recommended.
3. Exercise care when handling the fixture to avoid cuts or abrasions.
4. If a ladder is needed, use sturdy ones and set them on flat level surface.

INSTALLATION FOR FLUSH MOUNT (PLEASE REFER TO FIG. 1)

TURN OFF POWER FROM THE MAIN CIRCUIT BEFORE INSTALLING FIXTURE.

INSTRUCTIONS

STEP 1 – PREPARING FOR INSTALLATION.

- A. Disconnect electrical power at fuse or circuit breaker box before installing or servicing any part of this fixture.
- B. Remove the fixture from carton; remove components from hardware kit.
- C. Remove the mounting bracket (5) to junction box (1) (not included) by tightening two screws B (4).

WIRING - All wiring must take place inside junction box.

CAUTION: Make sure power is off at the fuse or circuit breaker box. Check power wires for damage or scapres. If power supply wires are within three inches of LED driver, use wire suitable for at least 90°C (194°F).

NOTE: Most dwellings built before 1985 have supply wire rated to 60°C. Consult a qualified electrician to ensure correct branch circuit conductor before installing.

STEP 2 – FIXTURE WIRING CONNECTION

- A. Make all wire connections to appropriate wire. Secure with wire nuts (provided).
- B. Connect the green or bare wire from the fixture to the supply power source ground wire. Connect the white wire from the fixture to the white (N) wire from supply power source. Connect the black fixture wire to the black (L) wire from supply power source.

STEP 3 – COLOR TEMPERATURE ADJUSTMENT (15)

Adjust color temperature switch on back of fixture to the desired color temperature.

STEP 4 – MOUNTING

- A. Install fixture housing (2) to mounting bracket (5) by tightening four screws A (3) on left and right side to secure it.

STEP 5 – FOR WET APPLICATION

- A. Apply a small amount of silicone (not included), per manufacturer's recommendation, around the upper perimeter of the fixture (2) where it contacts with the surface of the wall but not the bottom.

STEP 6 – RESTORE POWER AT FUSE OR CIRCUIT BREAKER BOX

NOTE: IF LUMINAIRE IS ALTERED IN ANY WAY DURING INSTALLATION OR PHYSICAL DAMAGE OCCURS, WARRANTY WILL VOID.

FIG.1

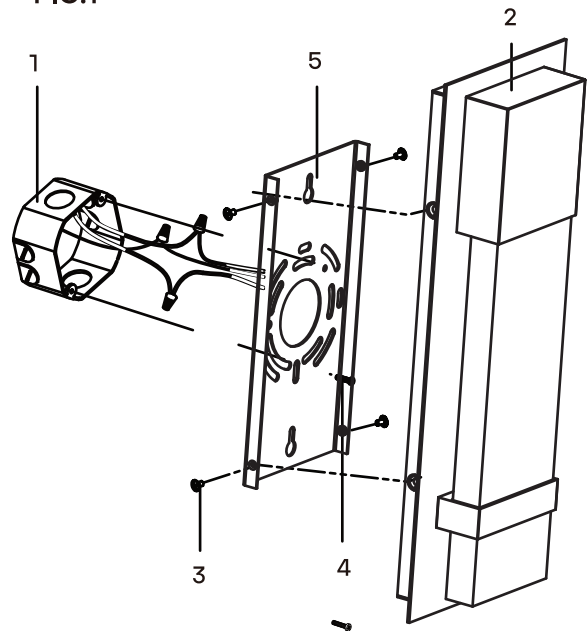
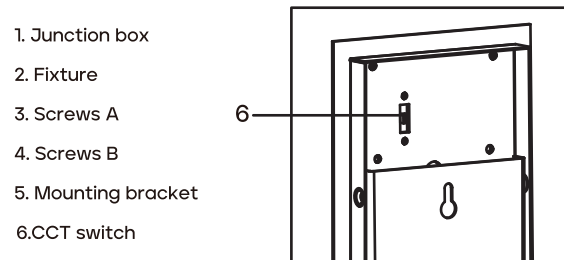

FIG.2



1. Junction box
2. Fixture
3. Screws A
4. Screws B
5. Mounting bracket
6. CCT switch