

# Emergency LED Driver ELB-XX48-IP65

## Features:

- Standard CSA C22.2 NO.141、UL924、IP65
- Selectable emergency power 8W,15W,20W,25W,30W
- Universal input (100–347VAC)
- Built-in Lithium Battery
- Battery protections: over charge protection, over discharge protection, short circuit protection
- The batteries meet 500 cycles of standard charge and discharge
- Silicone potted



RoHS

## Specifications

**Universal Input Voltage**  
100–347VAC, 50/60Hz

**AC Input Current**  
100mA max

**AC Input Power Rating**  
7.0W max

**Emergency Time**  
90 Minutes

**Full Warranty**  
5 Years

**Test Switch/Charging Indicator Light**  
Low Voltage,Illuminated Test Switch

**Battery Charging Current**  
≤250mA

**Recharge Time**  
≥24Hours

**Temperature Rating (Ambient)**  
Li-ion 0°C to 50°C (32F to 122F)

**Output Voltage**  
25-48VDC

Output Power	8W	15W	20W	25W	30W
Output Current	160-320mA	310mA-600mA	415-800mA	520-1000mA	625-1200mA
Battery Li-ion battery	7.4V/2500mAh	14.8V/2000mAh	11.1V/4000mAh	11.1V/5000mAh	14.8V/4000mAh

## Wiring Diagram:

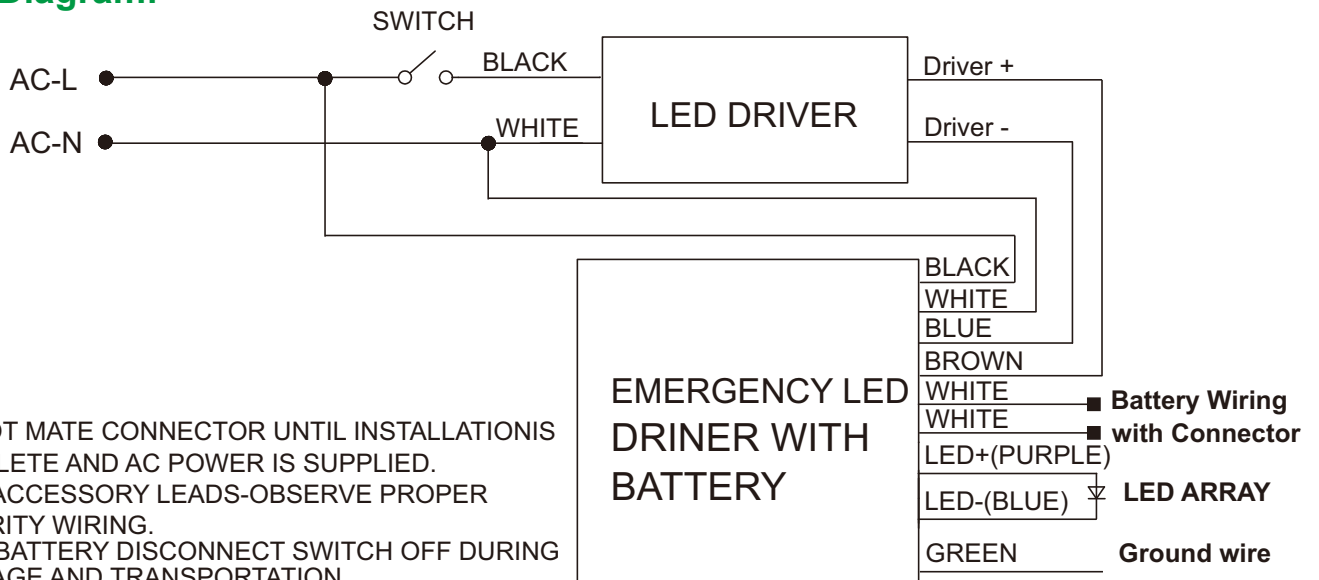

## Dimensions:

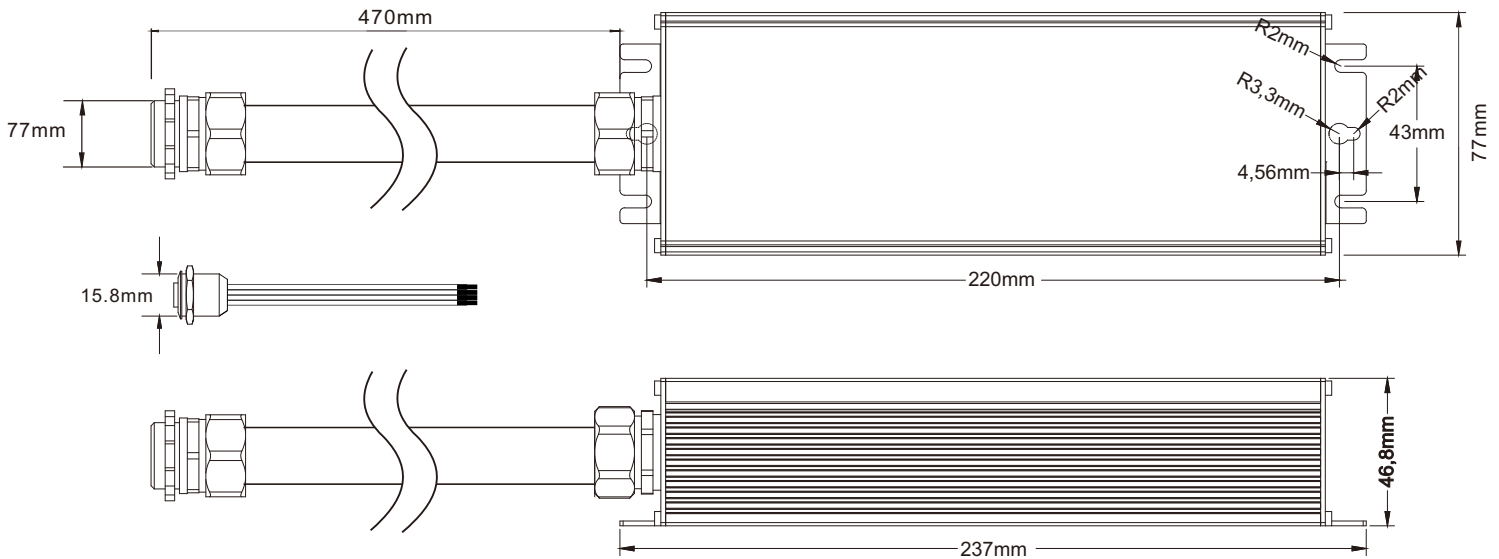

## SAFETY INSTRUCTIONS

- Risk of fire or electric shock. Luminaries wiring and electrical parts may be damaged when drilling for installation of LED emergency backup. Check for enclosed wiring and components.
- Risk of fire or electric shock. This LED emergency backup installation requires knowledge of luminaries electrical systems. If not qualified, do not attempt installation. Contact a qualified electrician.
- Before installing, make certain the AC power to the fixture is off.
- The electrical rating of this product is 100–347V. Installer must confirm that there is 100–347Vac the fixture before installation.
- To prevent electrical shock, only mate unit connector after installation is complete and before the AC power to the fixture is back on.
- This LED Emergency Backup unit requires an un-switched AC power source of 100–347V, 50/60 Hz. The AC driver must be on the same branch circuit as the LED emergency Backup unit.
- Do not let power supply cords touch hot surfaces.
- Do not mount near gas or electric heaters.

## Applications

The emergency driver can be used with most LED loads that have a rated voltage of 25-48Vdc. These emergency packs have been evaluated to and found compliant to UL 924. The emergency pack assembly is accepted as a component of a luminaire where the suitability of the combination shall be determined by UL or Authorities Having Jurisdiction. The as-installed performance of the system must meet or exceed all Federal, State, and Local code requirements.

## Operation

AC Operation: AC power is present. AC LED driver output current can not exceed 5A.

The emergency pack is charging in a standby mode. The test button will be lit, showing that the battery is charging.

Emergency Operation: When the AC power goes out, the emergency pack detects the power outage and automatically switches to the emergency mode. The LED load is illuminated, for a minimum of 90 minutes. When AC power is restored, the emergency pack switches back to normal mode and starts recharging.

## Testing Procedures

Press the test button, switch the system to emergency mode, and turn off the test light.

Release the test switch, switch the system to charging mode, and the test light is on.

For Initial testing, allow the unit to charge approximately 1 hour, then conduct a short discharge test.

Allow a 24 hour charge before conducting a one hour test.

NFPA 101, Life Safety Code outlines the following schedule:

Monthly-Insure that the test button light is illuminated. Conduct a 30 second discharge test by depressing the test button. The LED load should operate at reduced output.

Annually-Insure that the test button is illuminated. Conduct a full 90 minute discharge test. The unit should operate as intended for the duration of the test.