

INSTRUCTION MANUAL

31J22

EMERGENCY LIGHTING AND POWER EQUIPMENT



IMPORTANT SAFEGUARDS

WHEN USING ELECTRICAL EQUIPMENT, BASIC SAFETY PRECAUTIONS SHOULD ALWAYS BE FOLLOWED, INCLUDING THE FOLLOWING

READ AND FOLLOW ALL SAFETY INSTRUCTIONS

1. To prevent electric shock, switch off the mains power supply until installation is complete and AC power is supplied to this product.
2. This product requires an un-switched AC power supply of 120-277V, 50/60Hz.
3. Make sure all connections are in accordance with the National or Canadian Electrical code and any local regulations.
4. To reduce the risk of electrical shock, disconnect both normal and emergency power supplies and connector of this product before servicing.
5. It can provide minimum 90 minutes illumination under the emergency mode.
6. The product is UL Listed for field installation, and use with grounded, Listed fixtures and the case should be grounded. For ELB-CW-XX-MW-TERM/FLXS/EMTS/FLEX/EMTL, use with dry, damp location rated fixtures; For ELB-CW-XX-MW-IP66, use with wet location rated fixtures. The product is intended for ordinary locations and for permanent installation into one or more Listed emergency luminaires.
7. The ELB-CW-XX-MW-TERM/FLXS/EMTS/FLEX/EMTL are suitable for use in dry or damp locations. The ELB-CW-XX-MW-IP66 are suitable for use in outdoor or wet locations.
8. Use this product in -40°C minimum, 50°C maximum ambient temperatures (Ta).
9. Do not mount near gas or electric heaters.
10. Do not attempt to service the batteries. A sealed, non-maintenance battery is used that is not field replaceable. Contact the manufacturer for information or service.
11. The use of accessory equipment not recommended by the manufacturer may cause an unsafe condition and void warranty.
12. Do not use this product for other than intended use.
13. Installation and service should be performed by qualified service personnel.
14. This product should be mounted in locations and at heights where it will not be subjected to tampering by unauthorized personnel.



**THIS PRODUCT CONTAINS A RECHARGEABLE LI-ION BATTERY.
THE BATTERY MUST BE RECYCLED OR DISPOSED OF PROPERLY.**

INSTALLATION



CAUTION: MAKE CERTAIN THE AC POWER IS OFF UNTIL THE INSTALLATION IS COMPLETE.

1. SPECIFICATION OF ELB-CW-XX-MW-YYYY SERIES MODEL

See the ELB-CW-XX-MW-YYYY MODEL SPECIFICATION below for the model selected.

ELB-CW-XX-MW-YYYY MODEL SPECIFICATION

MODEL	VOLTAGE OUTPUT	EMERGENCY OUTPUT
ELB-CW-9W-MW-YYYY	10-300 VDC	9 WATTS
ELB-CW-18W-MW-YYYY	20-300 VDC	18 WATTS
ELB-CW-27W-MW-YYYY	30-400 VDC	27 WATTS

2. INSTALLING THE ELB-CW-XX-MW-YYYY

The ELB-CW-XX-MW-TERM should be installed within the enclosure of Listed luminaire. The ELB-CW-XX-MW-FLXS/EMTS/FLEX/EMTL/IP65 can be mounted inside or outside (nearby or on top of) the luminaire.

The Max. mounting height of the emergency luminaire with ELB-CW-9W-MW-YYYY: 20.6ft (6.2m), ELB-CW-18W-MW-YYYY: 27.7ft (8.3m), ELB-CW-27W-MW-YYYY: 31.1ft (9.3m).

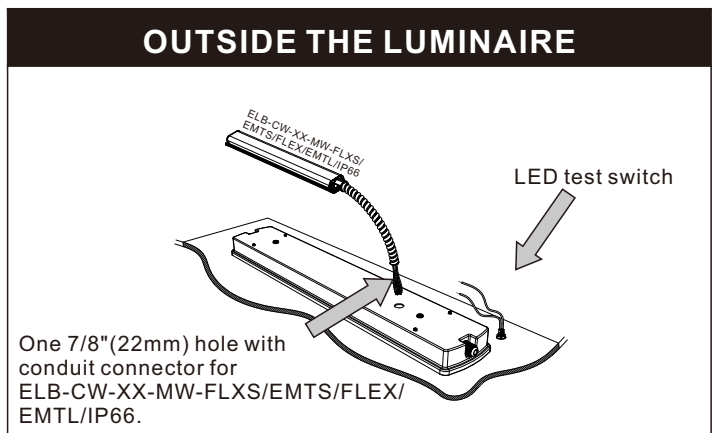
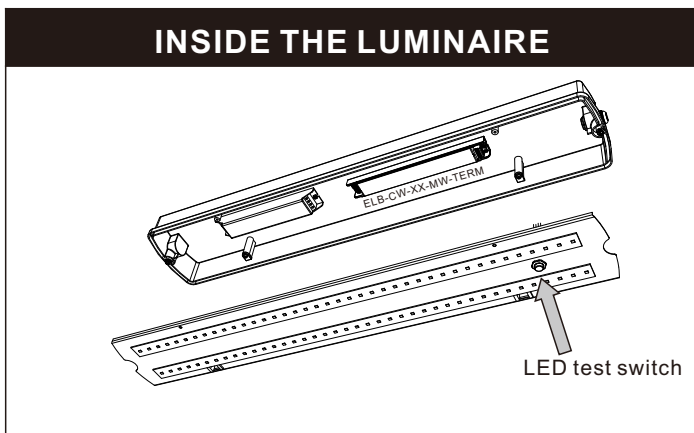

3. INSTALLING THE LED TEST SWITCH (LTS)

Select a convenient location for the LTS so that it can be seen after installation. Drill a 1/2" (12 mm) hole for mounting the LTS. Connect the wires from LTS to the ELB-CW-XX-MW-YYYY model according to the wiring diagram on page 3.

LTS-IP20

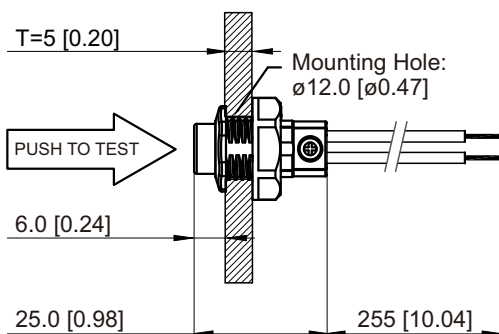

Dimension unit: mm [inch]

LTS-IP66

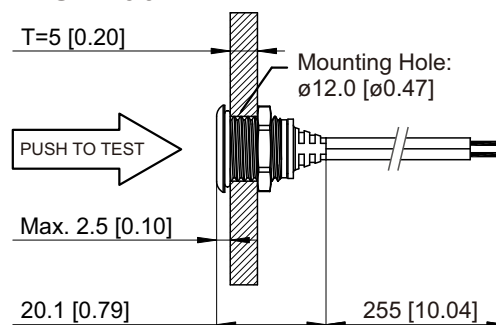

WIRING

1. The ELB-CW-XX-MW-YYYY requires an unswitched AC power supply of 120-277 volt, 50/60Hz.
2. The ELB-CW-XX-MW-YYYY and AC driver must be on the same branch circuit. Ensure the output current of the AC driver does not exceed 5A.
3. Refer the wiring diagrams below for wiring. Consult the factory for other wiring diagram.

FOR AC LED TUBE/BULB/LUMINAIRE

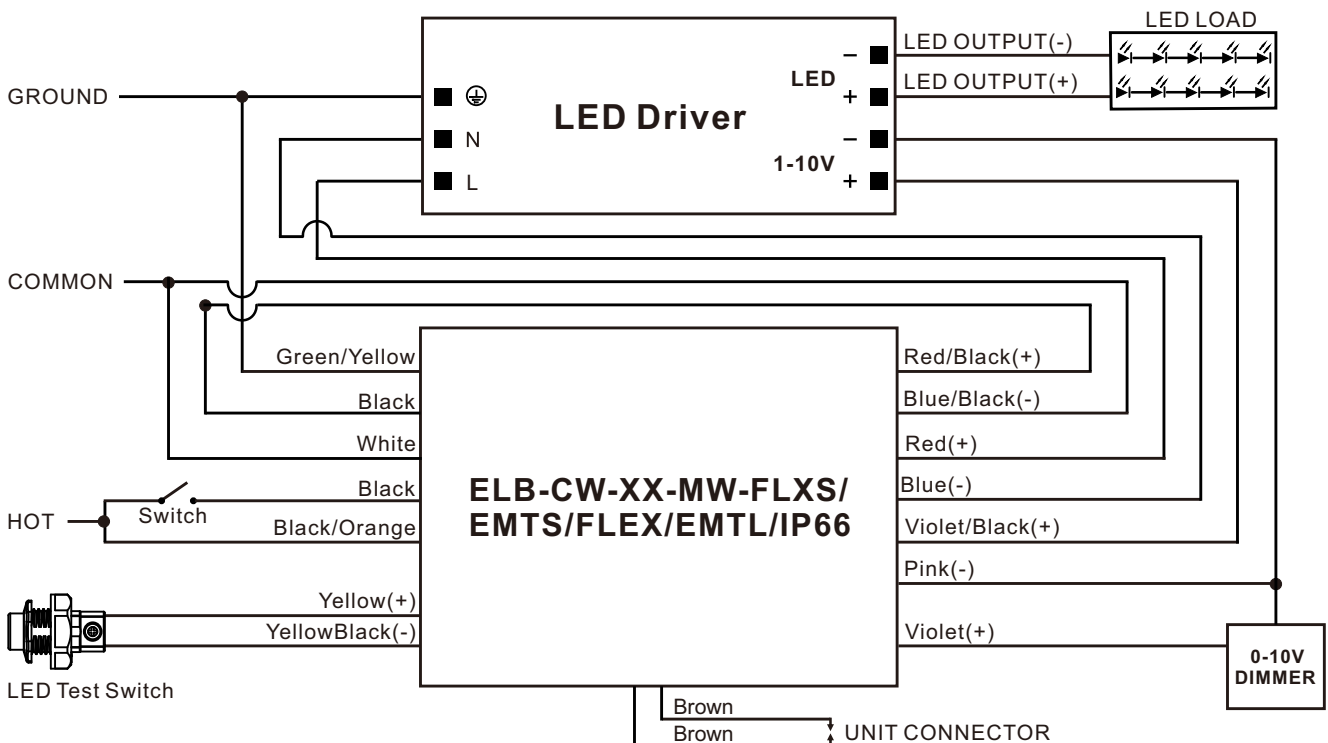
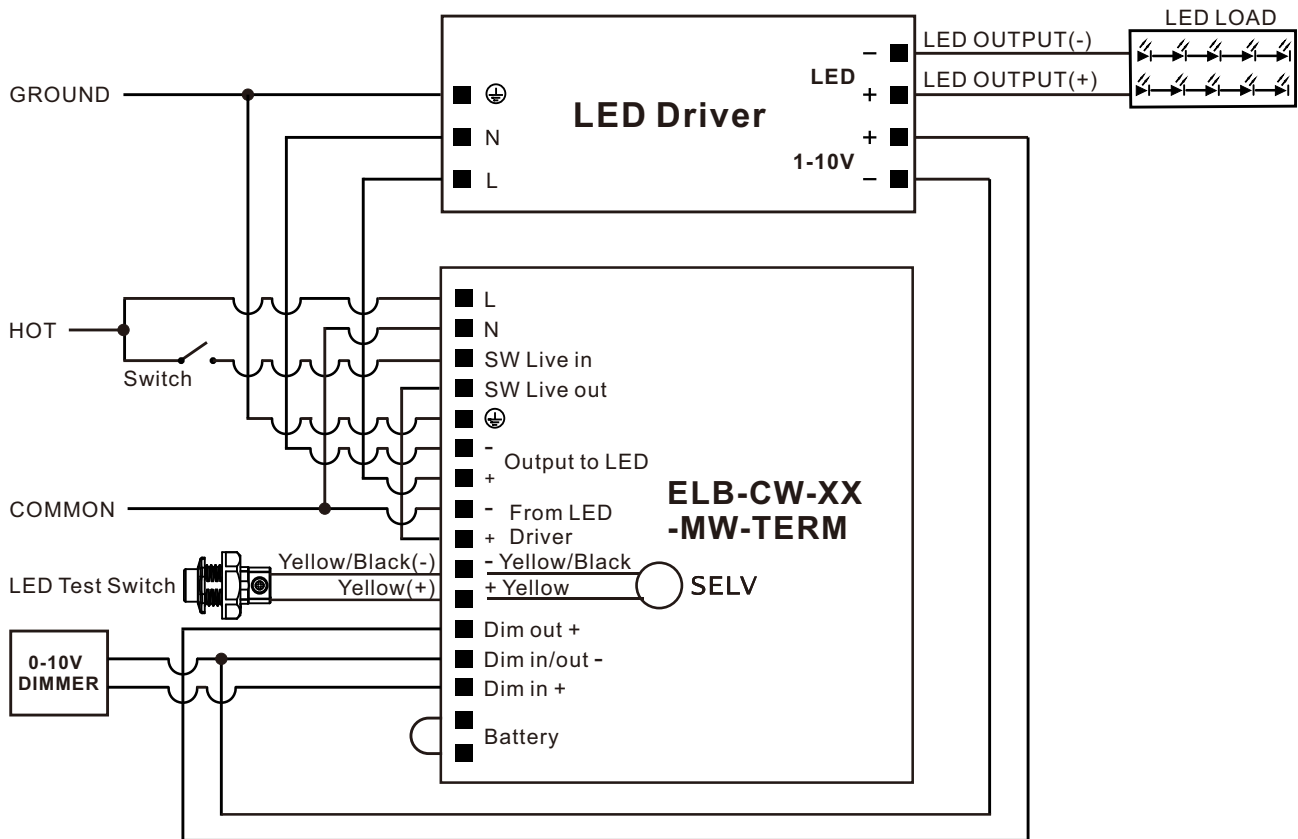

WIRING

FOR DC LED LOAD

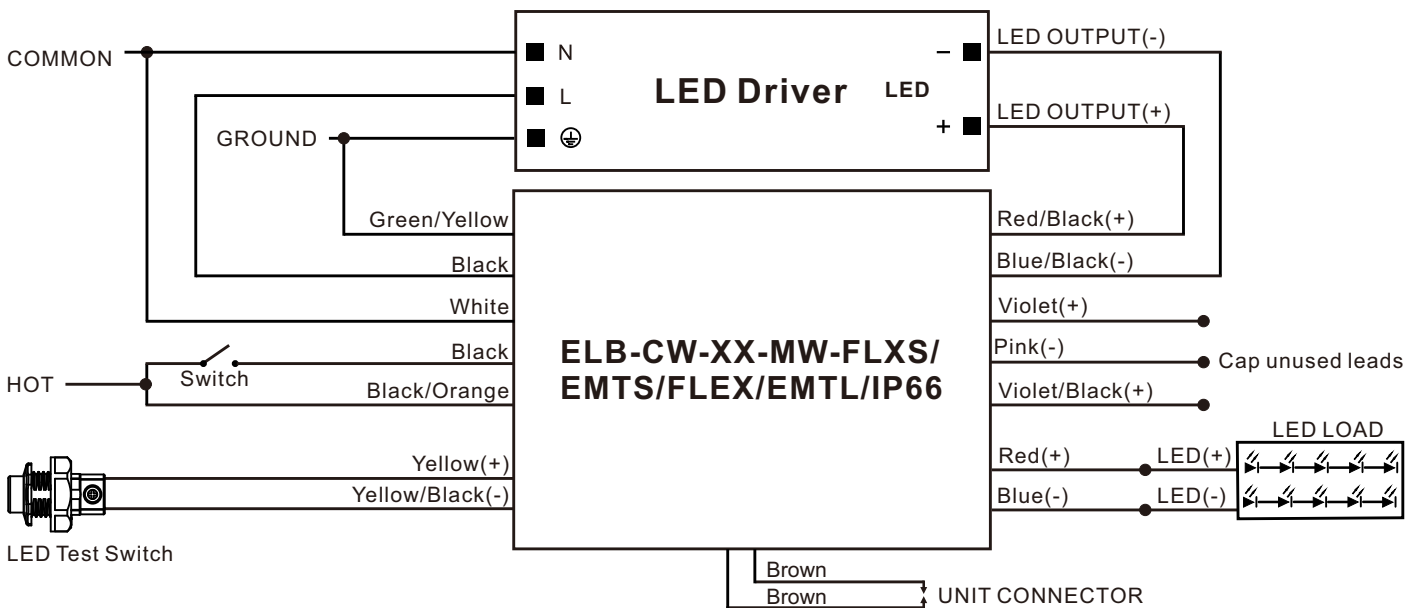
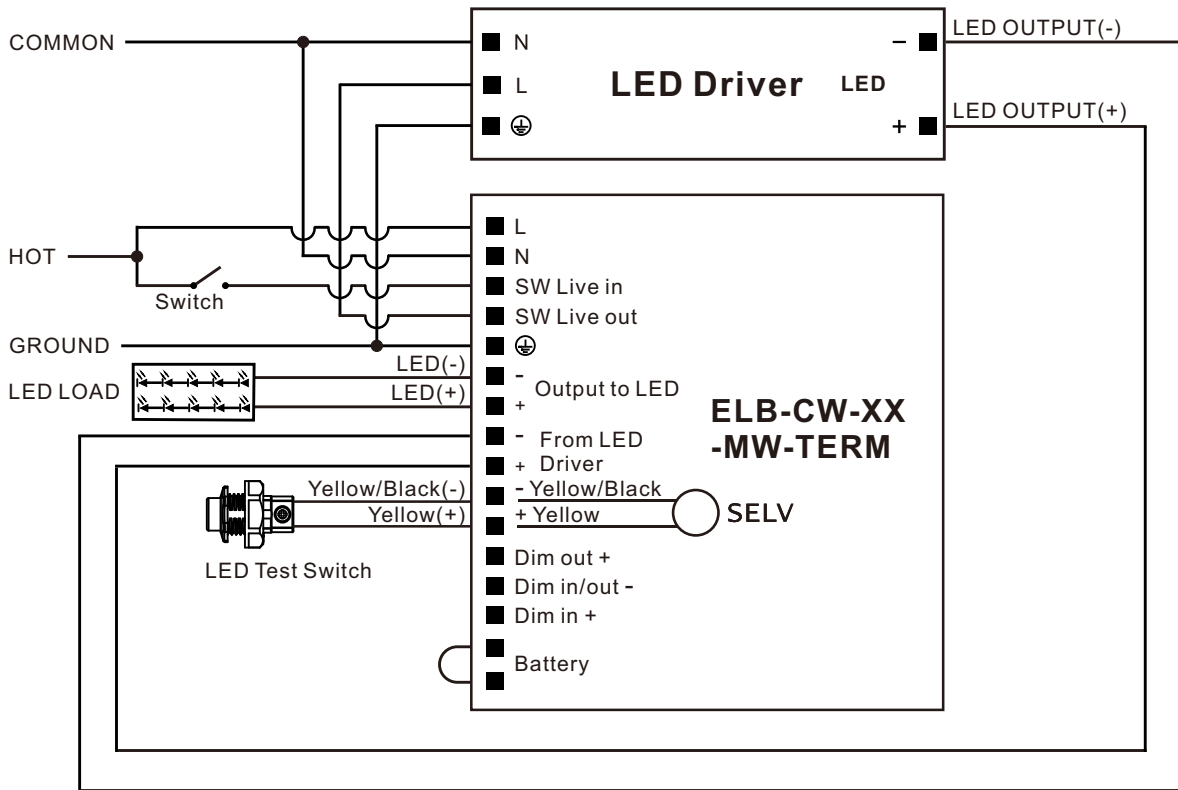

DIMENSION

Three wiring configurations of ELB-CW-XX-MW-YYYY series are as below:

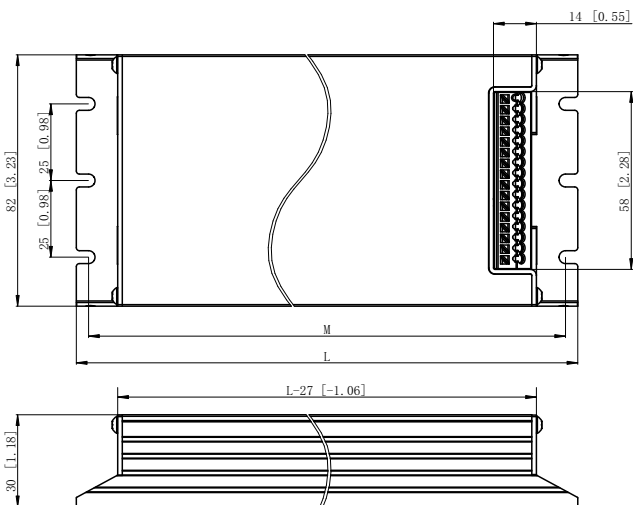
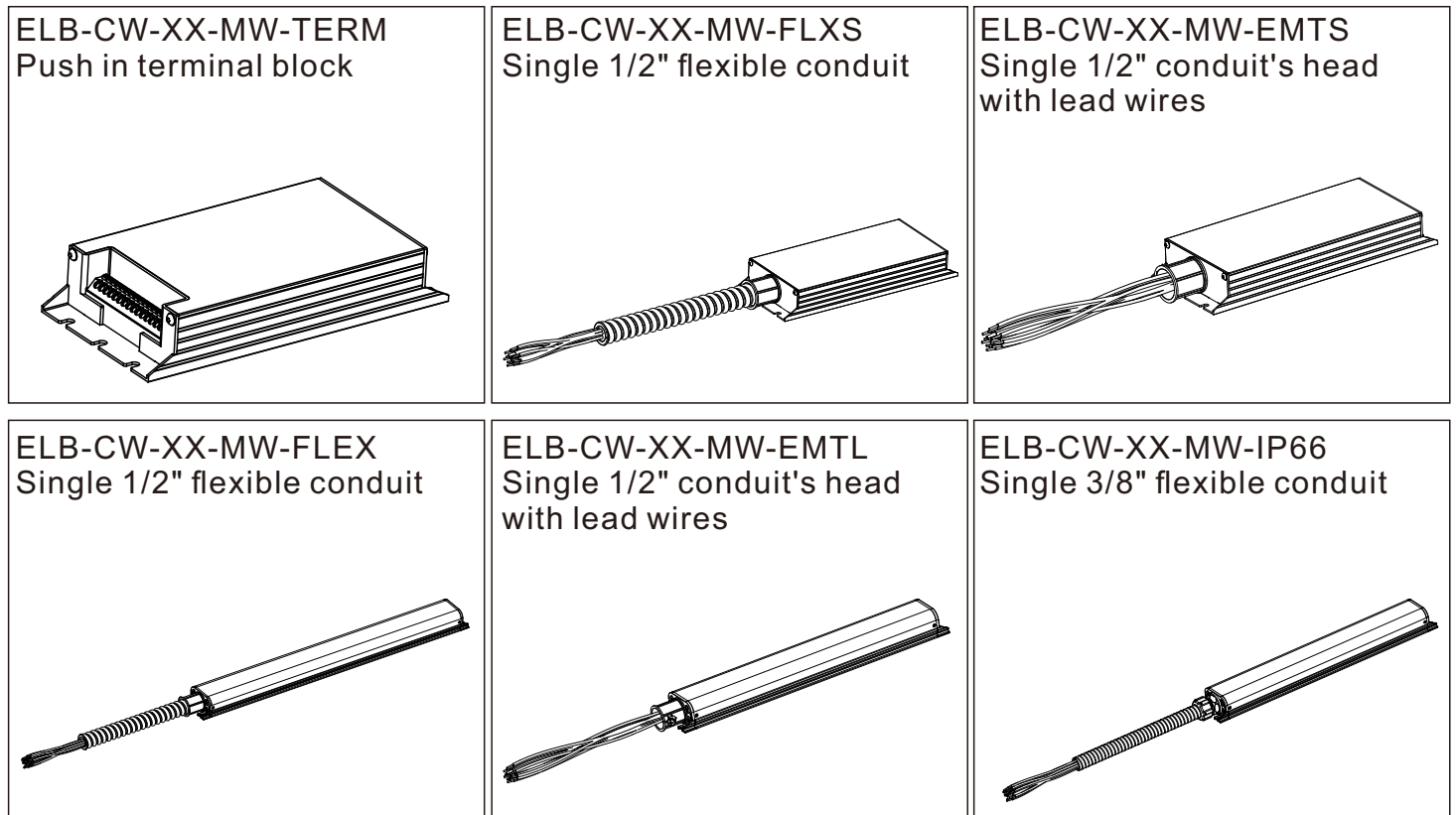

Dimension unit: mm [inch]

Item No.	ELB-CW -9W-MW- TERM	ELB-CW -18W-MW -TERM	ELB-CW -27W-MW -TERM
L mm [inch]	165 [6.50]	205 [8.07]	245 [9.65]
M (Mounting) mm [inch]	157 [6.18]	197 [7.76]	237 [9.33]
W mm [inch]	82 [3.23]	82 [3.23]	82 [3.23]
H mm [inch]	30 [1.18]	30 [1.18]	30 [1.18]

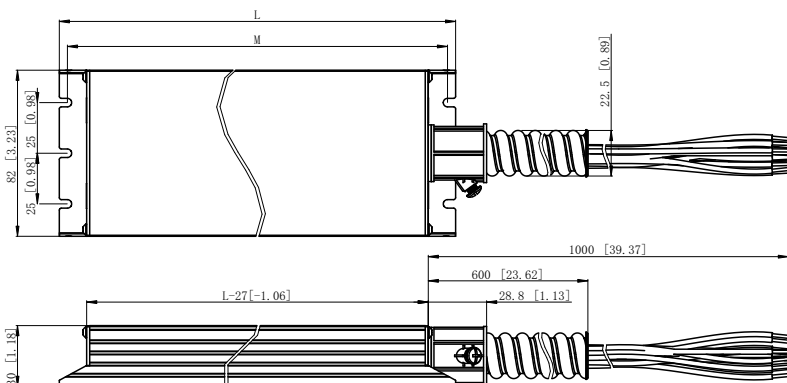

Item No.	ELB-CW -9W-MW- FLXS/ EMTS	ELB-CW -18W-MW -FLXS/ EMTS	ELB-CW -27W-MW -FLXS/ EMTS
L mm [inch]	208 [8.07]	245 [9.65]	285 [11.22]
M (Mounting) mm [inch]	197 [7.76]	237 [9.33]	277 [10.91]
W mm [inch]	82 [3.23]	82 [3.23]	82 [3.23]
H mm [inch]	30 [1.18]	30 [1.18]	30 [1.18]

DIMENSION

ELB-CW-XX-MW-FLEX/EMTL

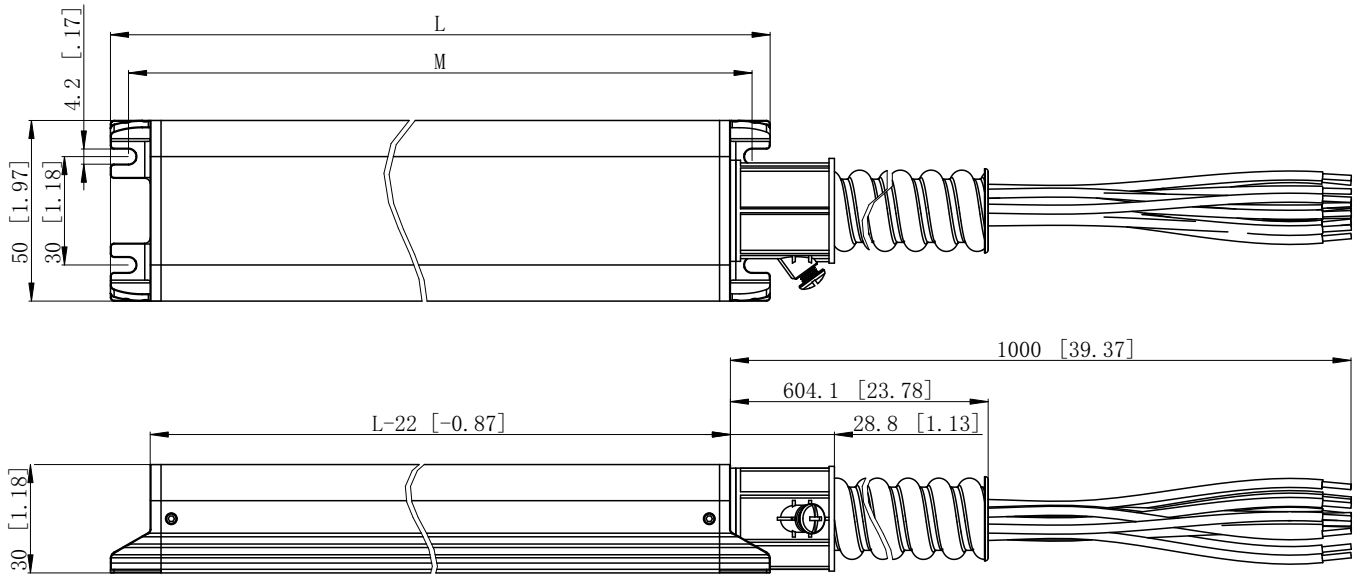

ELB-CW-XX-MW-IP66

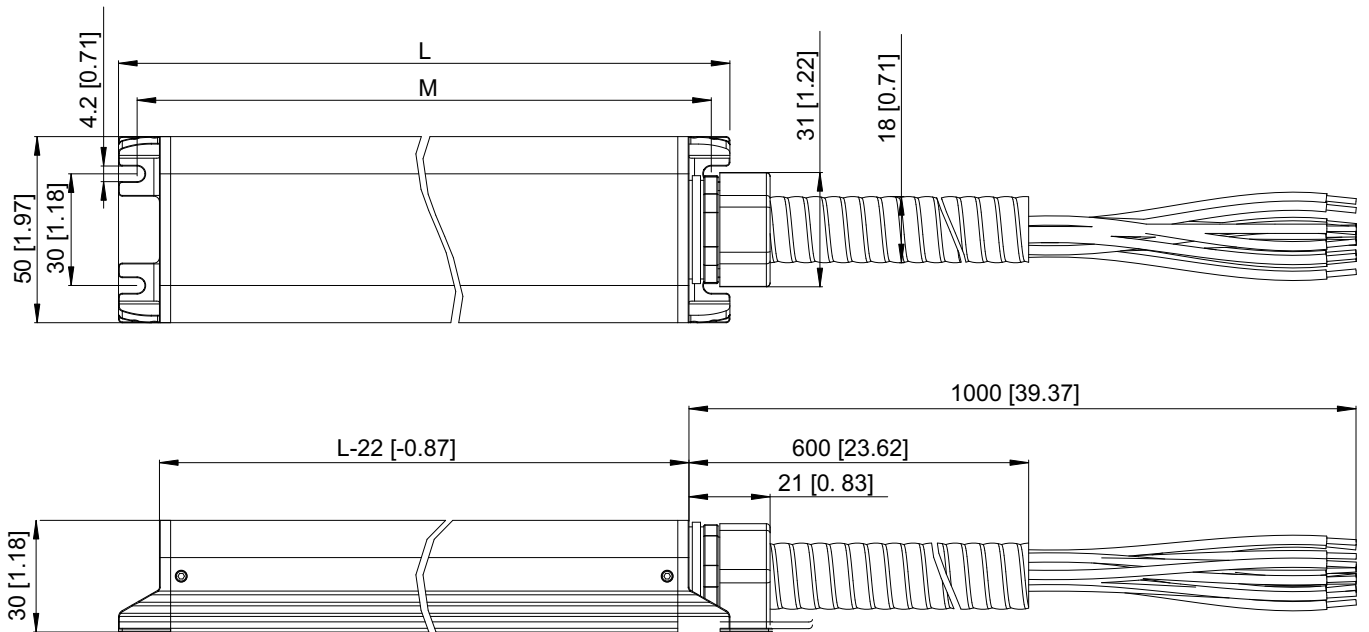

Dimension unit: mm [inch]

Item No.	L mm [inch]	M (Mounting) mm [inch]	W mm [inch]	H mm [inch]
ELB-CW-9W-MW-FLEX/EMTL/IP66	330 [12.99]	320 [12.60]	50 [1.97]	30 [1.18]
ELB-CW-18W-MW-FLEX/EMTL/IP66	395 [15.55]	385 [15.16]	50 [1.97]	30 [1.18]
ELB-CW-27W-MW-FLEX/EMTL/IP66	458 [18.03]	448 [17.64]	50 [1.97]	30 [1.18]

OPERATION / TESTING / MAINTENANCE

OPERATION

When AC power is applied, the LED test switch is illuminated, indicating that the batteries are being charged. When AC power fails, the ELB-CW-XX-MW-YYYY automatically switches to emergency power, operating the lighting load at rated emergency power. During power failure, the LED test switch will be off. When the AC power is restored, the emergency ELB-CW-XX-MW-YYYY switches the system back to normal mode of operation and resumes battery charging. The minimum emergency operation time is 90 minutes. A short term discharge test may be conducted after the ELB-CW-XX-MW-YYYY has been charging for 1 hour. The charging time for a full discharge is 24 hours.

TESTING AND MAINTENANCE

The following Periodic testing is recommended to ensure the system is working correctly.

1. Visually inspect the LED test switch (LTS) monthly. It should be illuminated when AC power is applied.
2. Conduct a 30-second discharge test by switching off the emergency breaker every month. The LTS will be off.
3. Conduct a 90-minute discharge test once per year. The LTS will be off during test.

AUTO TEST

The ELB-CW-XX-MW-YYYY has an Auto Test feature which saves cost by reducing the need for manual testing.

1. Initial Auto Test

When the system is connected properly and powered on, the ELB-CW-XX-MW-YYYY will perform an initial Auto Test. If any abnormal conditions exist, the LTS will blink quickly. Once the abnormal condition is corrected, the LTS will function correctly.

2. Preprogrammed Scheduled Auto Test

a) The unit will conduct the first Monthly Auto Test after 24 hours and up to 7 days after initial power on. Then monthly tests will be performed every 30 days.

b) Annual Auto test will occur every 52 weeks after initial power on.

- Monthly Auto Test

The Monthly Auto Test shall be executed every 30 days, and will test;

Shifting between normal and emergency mode, charging and discharging conditions.

Monthly test time is approximately 60 seconds.

- Annual Auto Test

Annual Auto Test will occur every 52 weeks after the initial 24 hours full charge, and will test;

Proper initial battery voltage, 90-minute emergency operation and acceptable battery voltage at the end of the full 90-minute test.

If the Auto Test is interrupted by a power failure, a full 90-minute Auto Test will occur again 24 hours after the power is restored. If the power failure causes the battery to fully discharge, the product will restart the Initial Auto Test and Preprogrammed Scheduled Auto Test.

MANUAL TEST

1. Press the LTS 1 time to force a ten-second emergency test.

2. Press the LTS 2 times continuously within 3 seconds to force a 60-second monthly test. After the test is completed, the next (30-day) monthly test will count from this date.

3. Press the LTS 3 times continuously within 3 seconds to force a 90-minute annual test. After the test is completed, the next (52-week) annual test will count from this date.

4. During any manual test, press and hold the LTS for greater than 3 seconds to terminate a manual test. The Preprogrammed Scheduled Auto Test time will not change.

LED TEST SWITCH CONDITIONS

LTS Slow Blinking: Normal Charging

LTS On: Battery Fully Charged - Normal Mode

LTS Off: Power Failure

LTS Gradual Change: In Testing Mode

LTS Quickly Blinking: Abnormal Condition - Corrective Action Required

GUIDELINE FOR FIELD INSTALLATION

The ELB-CW-XX-MW-YYYY series model is suitable for field installation with suitable LED loads including LED luminaires, LED lamps and others. Follow below 3 steps to determine if your luminaire is eligible for field installation.

1) Determine Electrical Compatibility

Verify that the emergency driver (ELB-CW-XX-MW-YYYY series) selected does not exceed the power delivered to the LED loads (both voltage and current) of the normal LED driver.

2) Calculate Lumen Output in Emergency Mode

- A) Access luminaire data from Designlights Consortium website (www.designlights.org).
- B) Select "Search the DLC Qualified Product List" on the DLC homepage.
- C) Enter luminaire manufacturer name and part number in the "search by keyword" text window.
- D) Select "Search" tab to open the "Qualified Products List".
- E) Determine luminaire Lumens per Watt efficacy in "Rated Data" specifications.
- F) Multiply luminaire Lumens per Watt by Emergency rated output of the ELB-CW-XX-MW-YYYY series model (Refer to below "ELB-CW-XX-MW-YYYY MODEL SPECIFICATION").

ELB-CW-XX-MW-YYYY MODEL SPECIFICATION

MODEL	EMERGENCY OUTPUT
ELB-CW-9W-MW-YYYY	9 WATTS
ELB-CW-18W-MW-YYYY	18 WATTS
ELB-CW-27W-MW-YYYY	27 WATTS

3) Determine Suitability of Means of Egress Lighting Levels

Using industry standard lighting design software with the IES files for the emergency luminaires, verify that the above calculated emergency lumens are sufficient to meet Code-compliant path of egress illumination levels.

While the ELB-CW-XX-MW-YYYY series has been found compliant with the requirements of UL Standard 924, it is ultimately the responsibility of the Designer/Specifier to assure the as-installed system delivers code-compliant path of egress illumination in accordance with national, state and local code requirements.