

# Narrow Strip Lights with EM & Sensor

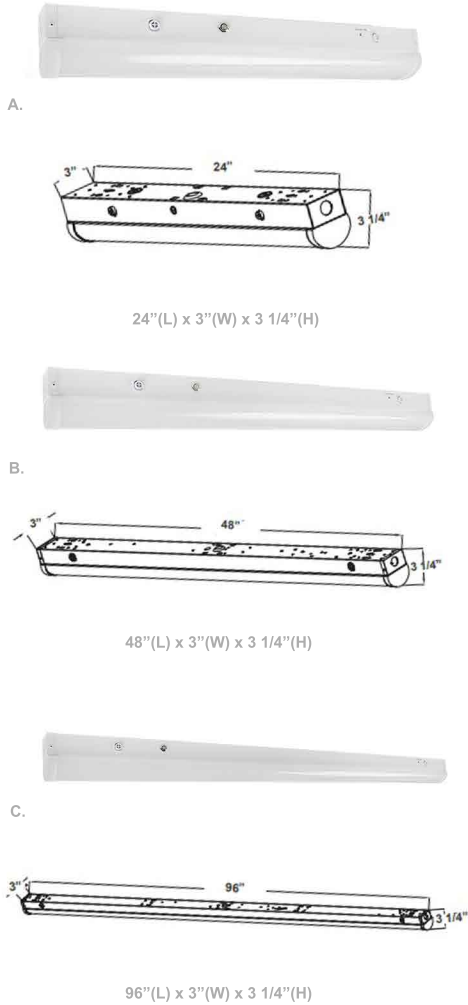

## Wattage

20W / 25W / 30W / 32W / 40W / 50W / 80W

## Voltage Input

120-277VAC 60Hz

## Efficacy

130 LPW

## Dimming

0~10V Dimmable

## Finish

Polycarbonate Frosted Lens  
Shatter Resistant Translucent Lens  
White Finish

## Color Temperatures



## Features



## Accessory



LSN-WG  
Wire Guard 2Ft/4Ft for LSN Strip Light

Catalog No.	Fig.	Catalog No.	Fig.
LSN-2FT-20W-MCT-D-SEN	A.	LSN-2FT-20W-MCT-D-EM-SEN	A.
LSN-4FT-40W-MCTP-D-SEN	B.	LSN-4FT-40W-MCTP-D-EM-SEN	B.
LSN-8FT-80W-MCTP-D-SEN	C.	LSN-8FT-80W-MCTP-D-EM-SEN	C.

### Factory-Installed Options

Watts	EM Options	Description	Plug-In Cord	Description	Paint	Sensor	Description
ALL MODELS	OPT-EM-CM1INT	INTERNAL	OPT-HBC-125TL-BK	8FT,15A,125V,WHT	N/A	OPT-SEN-2US INTERNAL FOR ALL MODELS	ULTRASONIC BI-LEVEL DIMMING (REMOTE NOT NEEDED)
	OPT-EM-CM1INT	INTERNAL	OPT-HBC-277TL-WH	8FT,15A,277V,WHT		WEC-3RC	OPTIONAL RC
	OPT-EM-CM1INT	INTERNAL	OPT-HBC-1255B-WH	10FT,15A,125V,18/3STR,WHT			