

565IS

Greensand Filter

Owners Manual



Proud member of Canadian Institute of Plumbing & Heating.



Proud member of Canadian Water Quality Association.

1. Read all instructions carefully before operation.
2. Avoid pinched o-rings during installation by applying (provided with install kit) NSF certified lubricant to all seals.
3. This system is not intended for treating water that is microbiologically unsafe or of unknown quality without adequate disinfection before or after the system.

REVISION # 0
REVISION DATE May 4, 2015
54585

Canadian Head Office
655 Park St.
Regina, SK S4N 5N1

Table of Contents

	PAGE
Unpacking / Inspection	2
Safety Guide	2
Proper Installation	3
Specification	4
Before Starting Installation	5
Sizing Requirements	7
Installation Instructions	8
System Start Up	9
Plumbing Clean Up	11
Programming	12
About The System	13
Maintenance	15
Sanitizing Procedure	15
Main Repair Parts	16
Trouble Shooting	23
Warranty	24

Unpacking / Inspection

Be sure to check the entire unit for any shipping damage or parts loss. Also note damage to the shipping cartons. Contact the transportation company for all damage and loss claims. The manufacturer is not responsible for damages in transit.

Small parts, needed to install the softener, are in a parts bag. To avoid loss of the small parts, keep them in the parts bag until you are ready to use them.

Safety Guide

For your safety, the information in this manual must be followed to minimize the risk of electric shock, property damage or personal injury.

- Check and comply with your provincial / state and local codes. You must follow these guidelines.
- Use care when handling the filter tank. Do not turn upside down, drop, drag or set on sharp protrusions.
- The system works on 12 volt-60 Hz electrical power only. Be sure to use only the included transformer.
- Transformer must be plugged into an indoor 120 volt, grounded outlet only.
- **WARNING:** This system is not intended for treating water that is microbiologically unsafe or of unknown quality without adequate disinfection before or after the system.

Proper Installation

This water filter system must be properly installed and located in accordance with the Installation Instructions before it is used.

- **Do not** install or store where it will not be exposed to temperatures below freezing or exposed to any type of weather. Water freezing in the system will break it. Do not attempt to treat water over 100°F.
- **Do not** install in direct sunlight. Excessive sun or heat may cause distortion or other damage to non-metallic parts.
- Properly ground to conform with all governing codes and ordinances.
- Use only *lead-free solder and flux* for all sweat-solder connections, as required by state and federal codes.
- Maximum allowable inlet water pressure is 125 psi. If daytime pressure is over 80 psi, night time pressure may exceed the maximum. Use a pressure reducing valve to reduce the flow if necessary.
- **WARNING:** Discard all unused parts and packaging material after installation. Small parts remaining after the installation could be a choke hazard.

Specifications

Specifications	565IS-75	565IS-100	565IS-150	565IS-200	565IS-300
Service Flow Rates					
Normal	3.0 gpm	3.0 gpm	4.0 gpm	5.0 gpm	6.0 gpm
Peak	4.0 gpm	5.0 gpm	8.0 gpm	10.0 gpm	12.0 gpm
Backwash Flow Rate	3.5 gpm	4.0 gpm	5.0 gpm	7.0 gpm	10.0 gpm
Compensated Iron Removal Capacity	4,500 ppm	6,000 ppm	9,500 ppm	12,000 ppm	18,000 ppm
KMnO ₄ per Regen	4 oz	4 oz	4 oz	8 oz	8 oz
Filter Media Volume - Cubic Feet	0.75 ft ³	1.0 ft ³	1.5 ft ³	2.0 ft ³	3.0 ft ³
Filter Tank Size	8x44	9x48	10x54	12x52	14x65
Tank Jacket / Media Loaded	Yes	Yes	Yes	No	No
Shipping Weight	113 lbs	129 lbs	179 lbs	233 lbs	352 lbs
Maximum Combination of Iron X 1, Manganese X 2, H ₂ S X3	10.0 ppm				
Maximum Iron (Ferrous)	7.0 ppm				
Maximum Manganese	5.0 ppm				
Maximum Hydrogen Sulfide	3.0 ppm				
Bacterial Iron	0.0 ppm				
Minimum pH	7.0				
Plumbing Connections	3/4" (Optional 1")				
Electrical Requirements	Input 120V 60 Hz - Output 12V 650mA				
Water Temperature	Min 39 - Max. 100 degrees Fahrenheit				
Water Pressure	Min. 20 - Max. 125 psi				

- Continuous operation at flow rates greater than the service flow rate may affect capacity and efficiency performance.
- The manufacturer reserves the right to make product improvements which may deviate from the specifications and descriptions stated herein, without obligation to change previously manufactured products or to note the change.
- Peak flow rates are intended for intermittent use only and are for residential application only
- At the stated service flow rates, the pressure drop through these devices will not exceed 15 psig

The system consists of three major components: a back washable filter containing oxygen charged manganese greensand, a chemical feeder with shutoff float which delivers an accurately measured volume of potassium permanganate solution for each regeneration, and a meter initiated control valve which governs the operation of the system.

As water passes through the filter bed, it comes in contact with the oxygen charged media. This causes iron, manganese and sulfur to oxidize. The undesirable compounds are then trapped in the filter bed. Eventually

the oxygen in the filter becomes depleted and regeneration is necessary.

Regeneration takes place during the night while you sleep. First, backwashing cleans the filter bed, and then concentrated potassium permanganate solution is passed through it, recharging the bed with oxygen. A rapid rinse removes any remaining potassium and a volume of water is returned to the feeder to dissolve enough potassium permanganate for the next regeneration. All functions are performed automatically.

Before Starting Installation

Tools, Pipe, and Fittings, Other Materials

- Pliers
- Screwdriver
- Teflon tape
- Razor knife
- Two adjustable wrenches
- Additional tools may be required if modification to home plumbing is required.
- Plastic inlet and outlet fittings are included with the softener. To maintain full valve flow, 3/4" or 1" pipes to and from the softener fittings are recommended. You should maintain the same, or larger, pipe size as the water supply pipe, up to the softener inlet and outlet.
- Use copper, brass, or PEX pipe and fittings.
- Some codes may also allow PVC plastic pipe.
- ALWAYS install the included bypass valve, or 3 shut-off valves. Bypass valves let you turn off water to the softener for repairs if needed, but still have water in the house pipes.
- 5/8" OD drain line is needed for the valve drain. A 10' length of hose is included with some models.
- A length of 5/8" OD drain line tubing is needed for the brine tank over flow fitting (optional).
- Nugget or pellet water softener salt is needed to fill the cabinet or brine tank.

Where To Install The Filter

- Place the filter tank as close as possible to the pressure tank (well system) or water meter (city water).
- Place the filter tank as close as possible to a floor drain, or other acceptable drain point (laundry tub, sump, standpipe, etc.).
- Connect the filter to the main water supply pipe BEFORE the water heater. **DO NOT RUN HOT WATER THROUGH THE FILTER.** Temperature of water passing through the filter must be less than 100 deg. F.
- Do not install the filter in a place where it could freeze. **Damage caused by freezing is not covered by the warranty.**
- Put the filter in a place water damage is least likely to occur if a leak develops. The manufacturer will not repair or pay for water damage.
- A 120 volt electric outlet, to plug the included transformer into, is needed within 6 feet of the filter. The transformer has an attached 6 foot power cable. **Be sure the electric outlet and transformer are in an inside location, to protect from wet weather.**
- If installing in an outside location, you must take the steps necessary to assure the filter, installation plumbing, wiring, etc., are as well protected from the elements, contamination, vandalism, etc., as when installed indoors.
- **Keep the filter out of direct sunlight.** The sun's heat may soften and distort plastic parts.

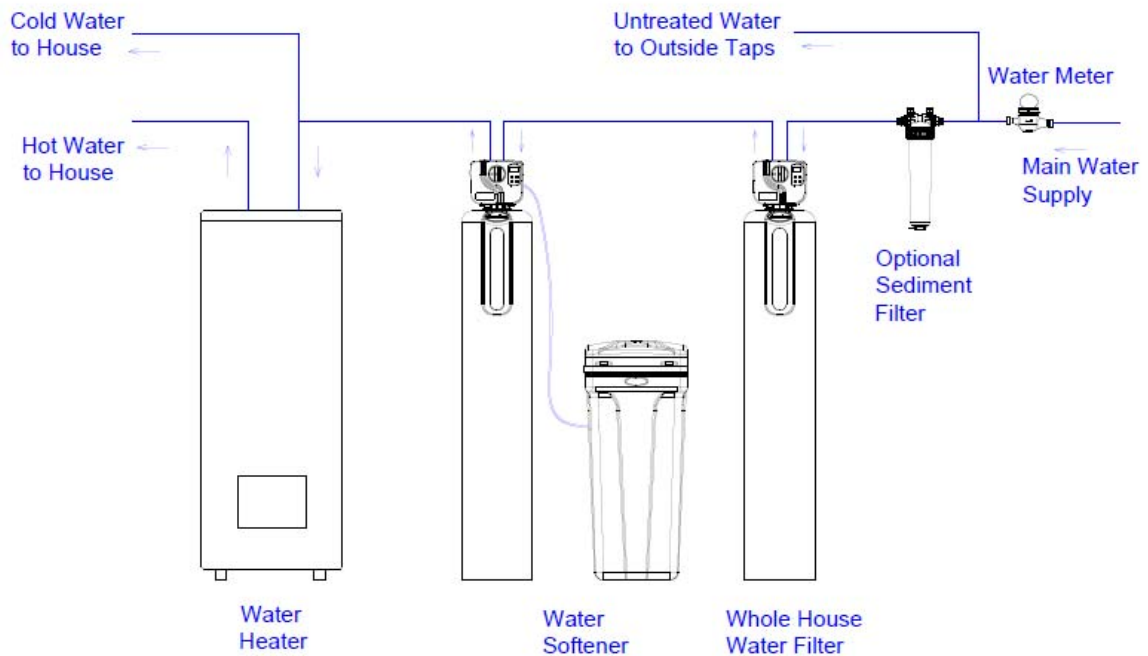

Sizing Requirements

Water Pressure

The water system must have a pump big enough to deliver the recommended backwash rate with a minimum pressure at the inlet of the filter of 30 psi. If the existing system cannot do this, it must be upgraded to do so. Whenever possible, the water system should be adjusted to deliver at least 30 psi for even more satisfactory results.

Backwash Flow Rates

The most important criteria in sizing a filter is the capacity of the pump. The water must pass through the filter media at the proper service flow rate. The filter must also be backwashed at a flow rate sufficient to dislodge and remove the captured particles. Failure to provide sufficient water will cause a build-up of particles in the filter media, impairing its ability. In order for your filter to backwash and rinse properly, your pump must be capable of providing the backwash flow rates indicated on page 4.

Check Your Pumping Rate

Two water system conditions must be checked carefully to avoid unsatisfactory operation or equipment damage:

1. Minimum water pressure required at the filter tank inlet is 20 psi.
2. Measuring the pumping rate of your pump:

With the pressure tank full, draw water into a container of known volume, and measure the number of gallons drawn until the pump starts again. This is draw-down. Divide this figure by cycle time and multiply the result by 60 to arrive at the pumping rate in gallons per minute (gpm). To aid in your calculation, insert the date in the following formula:

DRAW-DOWN _____ ÷ CYCLE TIME _____ x 60 = PUMPING RATE _____ (gals)
(secs.) (Gpm)

EXAMPLE: CYCLE TIME is 53 seconds. DRAW-DOWN is 6 gallons; then, PUMPING RATE equals:

$$6 \text{ gallons} \div 53 \text{ seconds} \times 60 = 6.8 \text{ gpm}$$

See chart on page 4 for minimum flow rates.

NOTE: If your pumping rate is inadequate for the model, do not install your filter until the problem has been corrected.

Capacity

An iron filter with one cubic foot of filter media regenerated with one Potassium Permanganate feeder will work well for most residential applications. For example, with iron in the range of 3-6 ppm, most filters will need to regenerate every two or three days providing an average family size of four or five people. The specification chart on page 4 shows the iron removal capacity in ppm that can be expected on automatic iron filters. The specifications are based on obtaining 6,000 ppm of capacity for each cubic foot of filter media. Two different Potassium Permanganate feeders are available – one feeding 2 oz. per regeneration, the other feeding 4 oz. In order to obtain the above capacities, the pH of the water being treated must be 7.0 or above. In the event the water is below 7.0, it must be treated with the appropriate equipment before going through the filter.

Removal Of Iron, Manganese & Hydrogen Sulfide ***IMPORTANT***

For the purpose of sizing a filter, consider 1 ppm of manganese equal to 2 ppm of iron and 1 ppm of hydrogen sulphide equal to 3 ppm of iron. Manganese and hydrogen sulphide (sulphur) are more difficult to oxidize than iron. Therefore, we suggest that, when making your sizing calculations and regeneration frequency calculations, calculate iron x 1, manganese x 2 and hydrogen sulphide x 3. All three must equal less than 10 ppm. Manganese is often present in water when iron is present. Hydrogen sulphide can normally be identified by a strong rotten egg odour.

Installation Instructions

1. If your hot water tank is electric, turn off the power to it to avoid damage to the element in the tank.
2. If you have a private well, turn the power off to the pump and then shut off the main water shut off valve. If you have municipal water, simply shut off the main valve. Go to the faucet, (preferably on the lowest floor of the house) turn on the cold water until all pressure is relieved and the flow of water stops.
3. Locate the filter tank close to a drain where the system will be installed. The surface should be clean and level.
4. Connect the inlet and outlet of the filter using appropriate fittings. Perform all plumbing according to local plumbing codes.
 - Use a ½" minimum pipe or tubing size for the drain line
 - **ON COPPER PLUMBING SYSTEMS BE SURE TO INSTALL A GROUNDING WIRE BETWEEN THE INLET AND OUTLET PIPING TO MAINTAIN GROUNDING.**

Any solder joints near the valve must be done before connecting any piping to the valve. Always leave at least 6" (152 mm) between the valve and joints when soldering pipes that are connected to the valve. Failure to do this could cause damage to the valve.

5. Connect the drain hose (10 ft included) to the valve and secure it with a hose clamp (also included). Run the drain hose to the nearest laundry tub or drain pipe. This can be ran up overhead or down along the floor. If running the drain line more than 20 ft overhead, it is recommended to increase the hose size to 3/4". NEVER MAKE A DIRECT CONNECTION INTO A WASTE DRAIN. A PHYSICAL AIR GAP OF AT LEAST 1.5" SHOULD BE USED TO AVOID BACTERIA AND WASTEWATER TRAVELLING BACK THROUGH THE DRAIN LINE INTO THE FILTER.
6. Connect the 3/8" tubing from the chemical feed tank to the valve.
7. Attach the 5/8" hose (supplied) to the over flow fitting on the feeder and run the hose to the floor drain.
8. Add water until there is approximately 1" (25 mm) of water above the grid plate. Do not add any chemical to the tank at this time.
9. Using the Allen Key (included), place the unit in the bypass position. Slowly turn on the main water supply. At the nearest cold treated water tap nearby remove the faucet screen, open the faucet and let water run a few minutes or until the system is free of any air or foreign material resulting from the plumbing work.
10. Make sure there are no leaks in the plumbing system before proceeding. Close the water tap when water runs clean.
11. Proceed to start up instructions.

Note: *The unit is not ready for service until you complete the start-up instructions.*

System Start-Up

Key Pad Configuration

- SETTINGS This function is to enter the basic set up information required at the time of installation.
- MANUAL REGEN This function is to initiate an immediate or delayed manual regeneration.
- DOWN / UP Increase or decrease the value of the settings while in the programming mode.

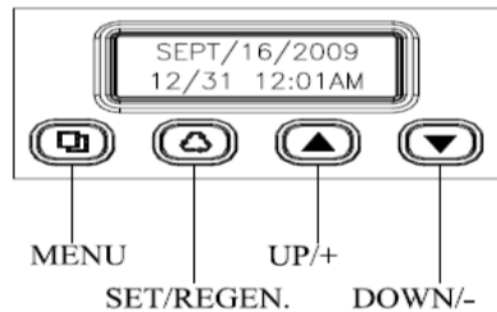

Manual Regeneration (Step / Cycle Valve)

DELAYED REGENERATION

Press and release the MANUAL REGEN. Button to set a delayed regeneration that will occur at the regeneration time. The main display page will show DELAYED REGEN ON. To cancel press and release the MANUAL REGEN. Button. The main display page will show DELAYED REGEN OFF.

IMMEDIATE REGENERATION

To start an immediate regeneration (or step valve through each position), press and hold the MANUAL REGEN. Button for 3 seconds (until beeps). The valve will start an immediate regeneration. Press any key to skip to the next cycle.

Start-up Instructions

1. Plug the power transformer into an approved power source. Connect the power cord to the valve.
2. When power is supplied to the control, the screen will display "INITIALIZING WAIT PLEASE" while it finds the service position.
3. Start an Immediate Manual Regeneration. The valve will immediately start moving to the BACKWASH position.
4. Once in the BACKWASH cycle, open the inlet on the bypass valve slowly and allow water to enter the unit. Allow all air to escape from the unit before turning the water on fully then allow water to run to drain for 3-4 minutes or until all media fines are washed out of the softener indicated by clear water in the drain hose.
5. Press any button to advance to the CHEM-DRAW position. Check the water level in the chemical feed tank to insure the valve is drawing water properly.
6. Press any button and advance to the RINSE position. Check the drain line flow. Allow the water to run for 3-4 minutes or until the water is clear.
7. Press any button to advance to the REFILL position. Check that the valve is filling water into the chemical tank. Allow the valve to refill until the float shuts off the water flow to the tank.
8. The valve will automatically advance to the SERVICE position. Open the outlet valve on the bypass, then open the nearest treated water faucet and allow the water to run until clear, close the tap and replace the faucet screen.
9. Cautiously pour Potassium Permanganate into the chemical tank. Replace the cover and the safety screws.
10. Manually initiate a regeneration after about one hour (time for the chemical to dissolve) to activate the manganese greensand.
11. Program unit.

Plumbing System Clean-Up

The following procedures are guidelines only but have proven successful in most instances. Under no circumstances should any procedure outlined below be followed if contrary to the appliance manufacturer's instructions. Should there be any questions concerning the advisability of performing a procedure, it is strongly recommended the manufacturer's authorized service outlet be consulted prior to performing the procedure.

The plumbing system and water using appliances that have been exposed, even for a

short time, to iron-fouled water need to be cleaned of the precipitated iron that has collected in them or iron bleed (staining) will continue to be a problem.

Depending on the amount of iron in the water and the length of time the water system has been exposed to iron fouling, select from the following procedures those that apply to the type of system and appliances that need to be cleaned to assure iron-free water at all points of use.

Softener

It isn't uncommon that the softener was installed in an effort to remove ferrous (clear water) iron from the water supply. Typically a softener will remove some ferrous iron until the resin bed becomes fouled to the extent that it will lose both hardness removal capacity and the limited capacity for iron removal. This is the condition to expect the softener to be in when planning a system clean-up. Prior to closing the main supply valve or turning power off to a private well system and preparatory to installing the filter system, do the following:

1. Disconnect the brine draw line from the brine cabinet and place the loose end into a five gallon plastic pail filled with a solution of warm water and 4 oz. of resin mineral cleaner.
2. Advance the control timer to the brine draw position (refer to instructions provided with your softener). Allow all the
3. Then immediately close the main water supply valve or turn the power off to the pump and proceed with the filter installation. During the time required to install the filter system, the iron-fouled softener resin will be chemically cleaned.
4. After the filter installation is completed and final adjustments have been made, with the water turned on and the brine draw tube reconnected, reposition the timer on the softener to the backwash position. Allow the timer to perform an automatic regeneration cycle. During backwash of the softener, all iron cleaned from the resin will be washed down the drain. It is advisable, after chemically cleaning the softener, to regenerate the system twice to fully restore capacity lost due to iron-fouling.

warm mineral cleaner solution to be drawn into the mineral bed.

Programming Instructions

Backwash Frequency

The table below can be used to help determine the frequency of regeneration for Multi-Media and Taste & Odour filters. Use this table as a guide since individual circumstances will require more or less frequent regenerations. This can be adjusted by the home owner to suite their individual needs with frequencies available from 1 – 99 days. To prevent bacterial build up in the media, activated carbon filters should not exceed 6 days between backwashes.

If the water heater has been exposed to both free iron and hardness for a long period of time, replacement of the heater tank may be the only practical solution to prevent continued staining originating from this source. After completing the installation of the chemical free iron filter, clean the water heater by following these instructions:

1. Shut off the energy supply to the water heater and close the heater inlet water valve.

1. Press SETTINGS to enter programming. If the system has been inactive, you may have to hold and press SETTINGS to unlock the display screen. Press UP or DOWN to select which setting to modify.
2. To adjust a value, MANUAL REGEN. When the display flashes, the value may be changed. Press UP or DOWN to change the value. Press MANUAL REGEN again to accept the value.
3. Press UP or DOWN to advance to the next option.
4. At any time, press SETTINGS to return to previous home screen menu.

Menu - Level 1

Press SETTINGS key

TIME
12:00AM

REG.TIME
12:00AM

DAYS
3

Page 1

Page 2

Example

STAR
PLUMBing

TEL (552)
764-1234

Manual Regeneration (Step / Cycle Valve)

If screen is locked, press and hold SETTINGS for 3 seconds to unlock. To initiate an immediate regeneration, press and hold the MANUAL REGEN key for 5 seconds. The valve will immediately start into manual regeneration.

To initiate a delayed regeneration, press the MANUAL REGEN key once to turn on and a regeneration will be queued at the next pre-set regeneration time (i.e. 2:00 a.m.).. To cancel, press the MANUAL REGEN key again.



About The System

Operation During A Power Failure

In the event of a power failure, the valve will keep track of the time and day for 48 hours. The programmed settings are stored in a non-volatile memory and will not be lost during a power failure. If power fails while the unit is in regeneration, the valve will finish regeneration from the point it is at once power is restored. If the valve misses a scheduled regeneration due to a power failure, it will queue a regeneration at the next regeneration time once power is restored.

New Sounds

You may notice new sounds as your water softener operates. The regeneration cycle lasts up to 180 minutes. During this time, you may hear water running intermittently to the drain.

Regeneration Process

Periodically the filter will require a back wash to clean the trapped particles and unpack the filter bed to restore the system flow rates. The table below explains the regeneration steps.

Step	Name	Description
#1	Back Wash	Fresh water is introduced to the bottom of the tank flowing upwards expanding the filter media to rinse out any dirt or small particles to the drain and to uncompact the bed to restore full service flow rates.
#2	Rinse	Fresh water is introduced from the top of the tank flowing down through the filter bed rinsing any unfiltered water to the drain.

Maintenance

Maintenance of your new water filter requires very little time or effort but it is essential. Regular maintenance will ensure many years of efficient and trouble-free operation.

1. Periodically make sure your pump is performing satisfactorily to ensure sufficient water is available for backwashing the filter.
2. Periodically test your raw and filtered water to ensure conditions are still the same for your original settings and that the unit is working the way it is intended to. Water testing is often the best way to determine when the filter media will require replacement.
3. Periodically check that the drain line is clear and free from any obstructions.

Manual Bypass

In the case of emergency, such as an overflowing brine tank, you can isolate your water softener from the water supply using the bypass valve located at the back of the control. In normal operation the bypass is open with the on/off knobs in line with the inlet and outlet pipes.

To isolate the softener, simply rotate the knobs clockwise (as indicated by the word BYPASS and arrow) until they lock. You can use your water related fixtures and appliances as the water supply is bypassing the softener. However, the water you use will be hard. To resume soft water service, open bypass valve by rotating the knobs counterclockwise.

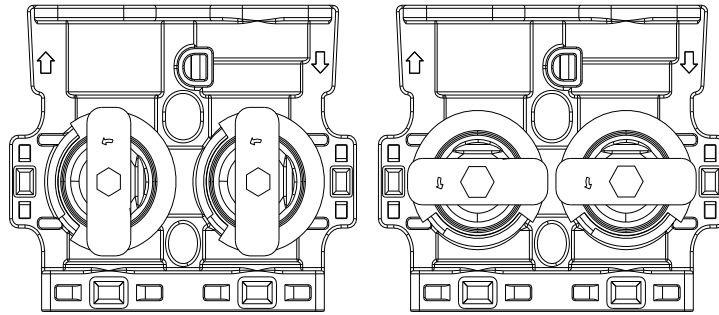

SERVICE POSITION

BYPASS POSITION

Cleaning or Replacing Injectors

Sediment, salt and silt will restrict or clog the injector. A clean water supply and pure salt will prevent this from happening.

The injector assembly is located on the right side of the control valve. This assembly is easy to clean.

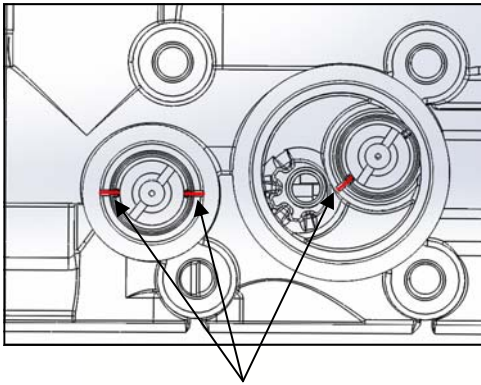

TIP: There are marks on the injector holder that must be lined up to the marks on the valve to fully insert the holder into the hole in the valve body

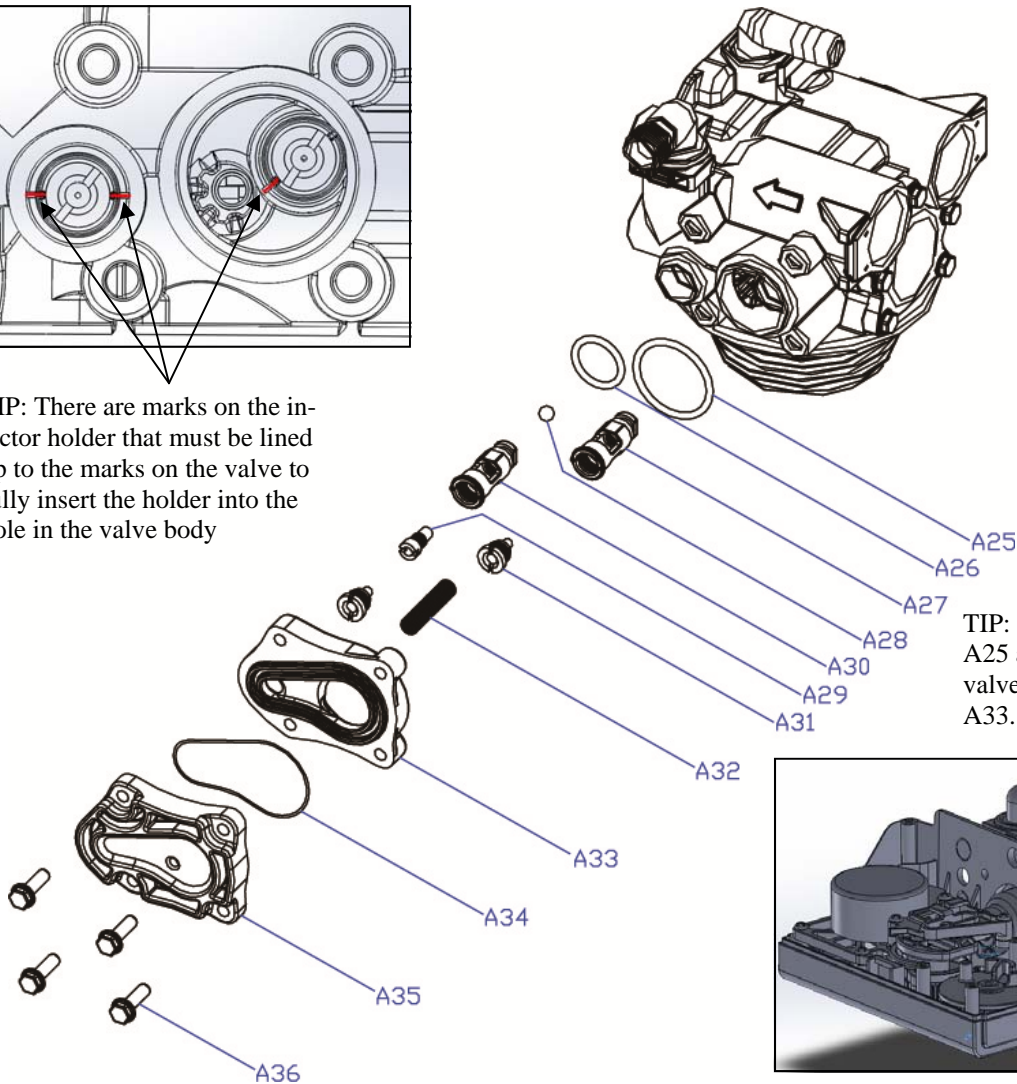

TIP: Place the o-rings A25 and A26 onto the valve before installing A33.

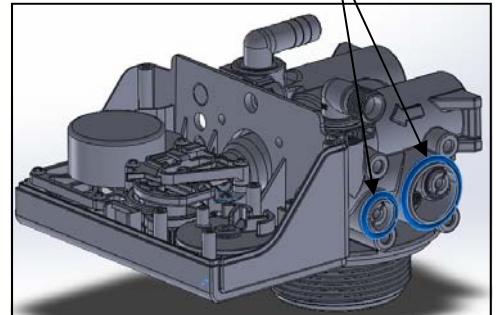

1. Shut off the water supply to your filter and reduce the pressure by opening a cold soft water faucet.
2. Using a screwdriver, remove the four screws holding the injector cover to the control valve body.
3. Carefully remove the assembly and disassemble as shown in above figure.
4. The injector orifice is removed from the valve body by carefully turning it out with a large screwdriver. Remove the injector throat the same way.
5. Carefully flush all parts including the screen. Use a mild acid such as vinegar or Pro-Rust Out to clean the small holes in the orifice and throat.
6. Reassemble using the reverse procedure.

Replacing Brine Line Flow Control (BLFC)

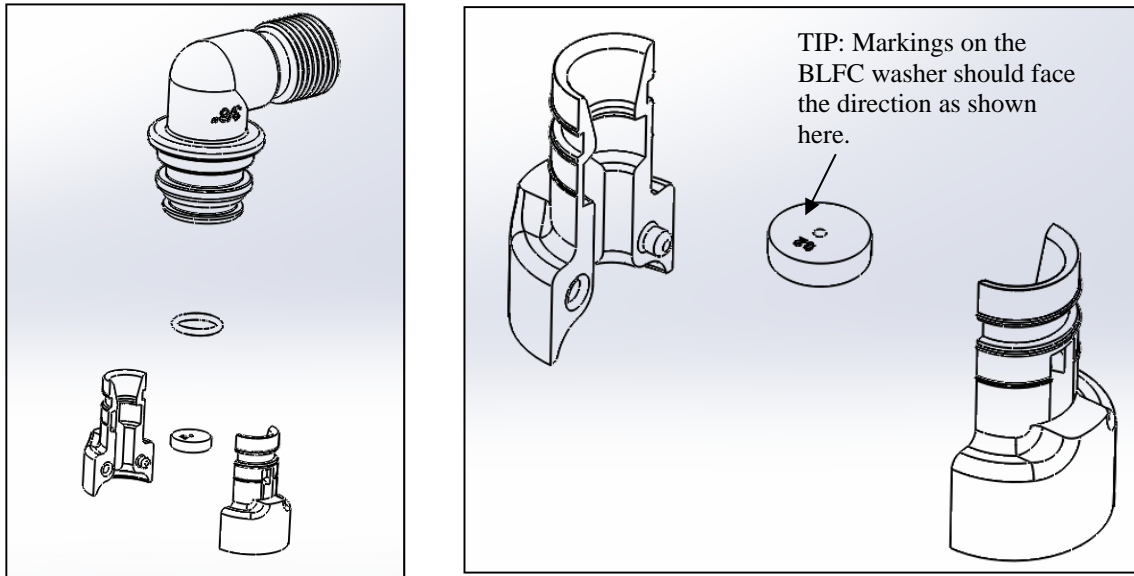

1. Remove the red clip that secures the brine elbow.
2. Remove the BLFC holder from the elbow fitting.
3. Split the BLFC holder apart and remove the flow washer.
4. Reassemble using the reverse procedure.

Replacing Drain Line Flow Control (DLFC)

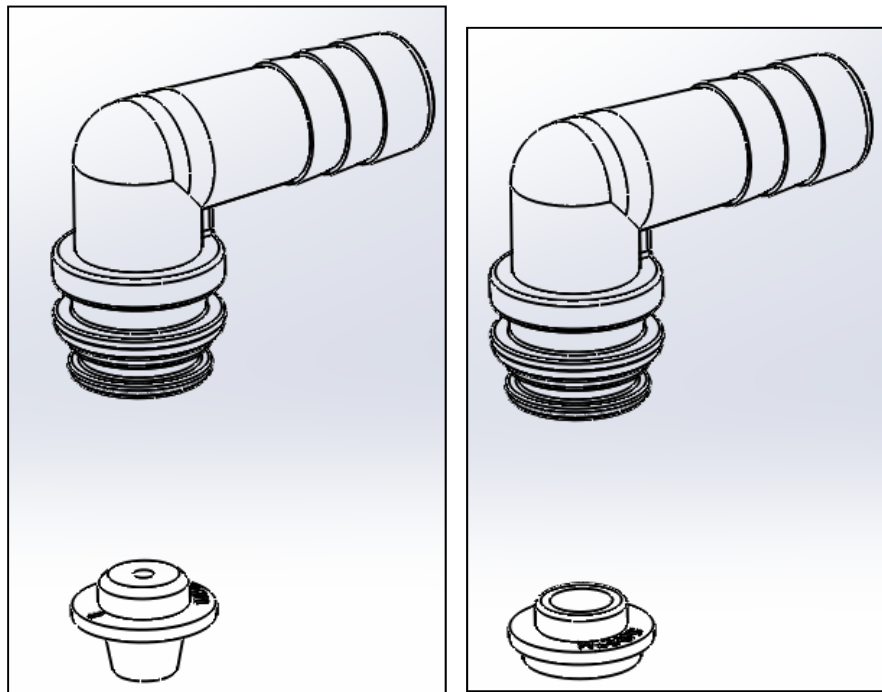

1. Remove the red clip that secures the drain line elbow.
2. Remove the BLFC washer from the elbow fitting.
3. Reassemble using the reverse procedure.

Main Repair Parts

Main Repair Parts - Connectors

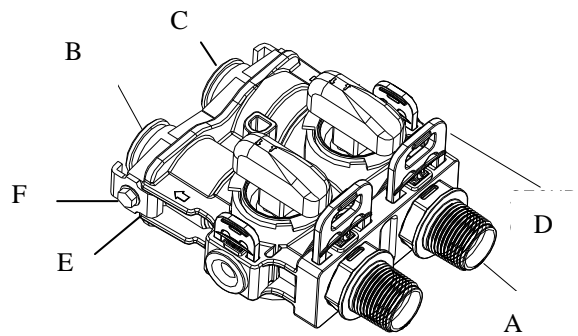
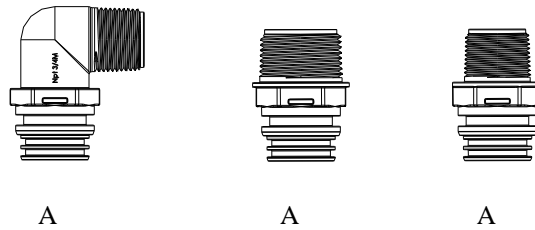

REPLACEMENT PARTS - CONNECTORS			
Replacement Part Number	Part Description	DWG #	Quantity
60010020	3/4" NPT ELBOW	A	2
60010019	1" NPT STRAIGHT	A	2
60010023	3/4" NPT STRAIGHT	A	2
60010079	VALVE COUPLING INLET	B	1
60010101	VALVE COUPLING OUTLET (METER SIDE)	C	1
60010025	PLASTIC SECURE CLIP	D	2
60010046	BYPASS SS CLIP	E	2
60010047	BYPASS SS SCREW	F	2

Control Valve Exploded View

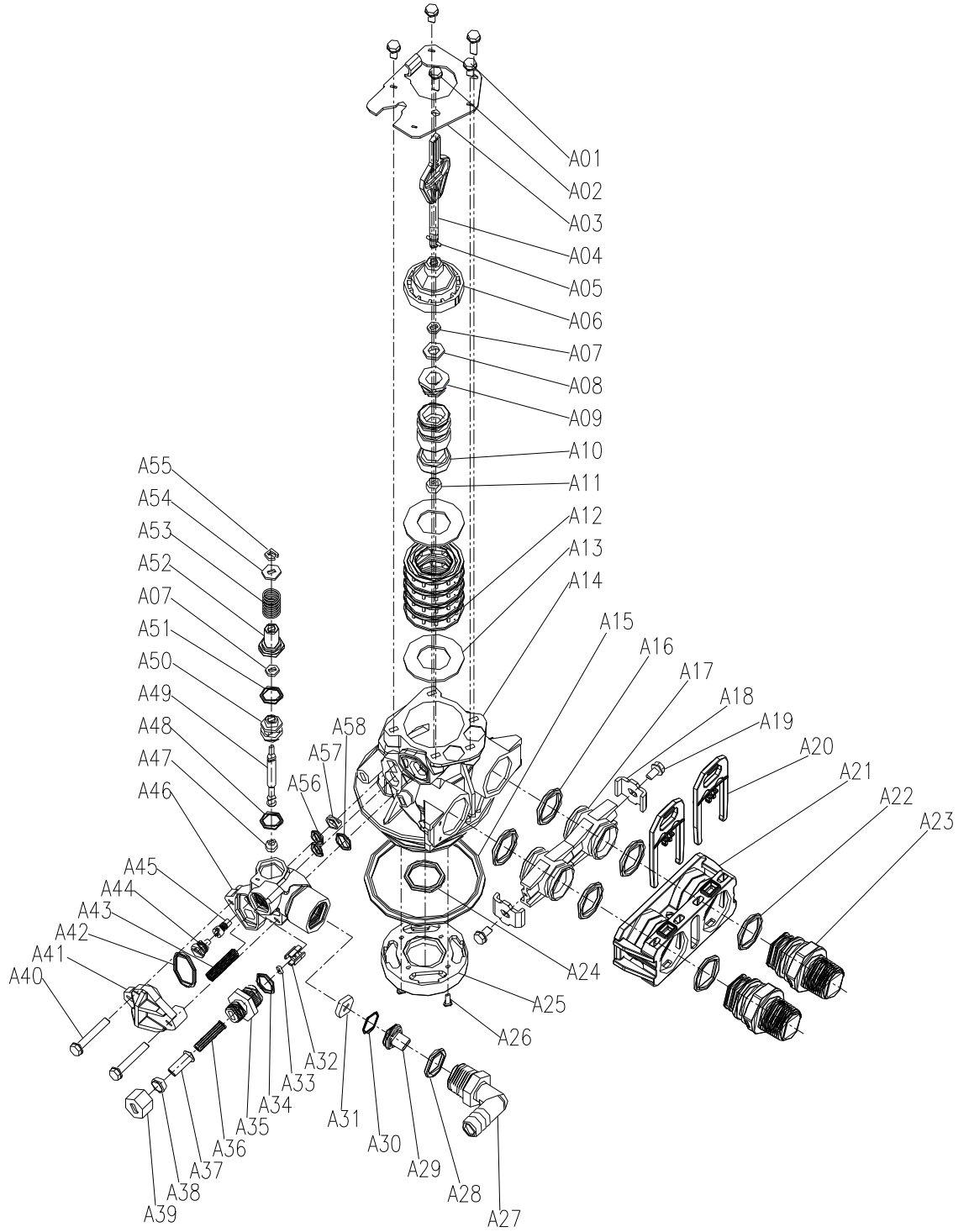

Control Valve Parts List

Item No.	Part No.	Part Description	Quantity
A01	05056087	Screw-M5×12(Hexagon)	3
A02	05056088	Screw-M5×16(Hexagon with Washer)	2
A03	05056047	End Plug Retainer	1
A04	05010081	Bnt65 Piston Rod	1
A05	05056097	Piston Pin	1
A06	05056023	End Plug	1
A07	05056070	Quad Ring	2
A08	05056024	End Plug Washer	1
A09	05056022	Piston Retainer	1
A10	05056181	Piston (Electrical)	1
A11	05056104	Muffler	1
A12	05056021	Spacer	4
A13	05056073	Seal	5
A14	05056019	Bnt65 Valve Body	1
A15	05056063	O-ring- ϕ 78.74×5.33	1
A16	05056129	O-ring- ϕ 23×3	4
A17	05056025	Adaptor Coupling	2
A18	05056044	Adaptor Clip	2
A19	05056090	Screw-ST4.2×13(Hexagon with Washer)	2
A20	21709003	Secure Clip	2
A21	05056140	Valve Connector	1
A22	05056065	O-ring- ϕ 23.6×2.65	2
A23	21319006	Screw Adaptor	2
A24	26010103	O-ring- ϕ 25×3.55	1
A25	07060007	Valve Bottom Connector	1
A26	13000426	Screw-ST2.9×13(Large Wafer)	2
A27	05056038	Drain Fitting	1
A28	26010003	O-Ring- ϕ 18×2.65	1
A29	05056036	DLFC Button Retainer	1
A30	05056079	O-Ring- ϕ 15×0.8	1
A31	05056143	DLFC-2#	1
A32	05056035	BLFC Button Retainer	1
A33	05056191	BLFC-2#	1
A34	05056138	O-Ring- ϕ 14×1.8	1
A35	05056100B	BLFC Fitting	1
A36	05056106	Brine Line Screen	1
A37	05056107	BLFC Tube Insert	1
A38	05056033	BLFC Ferrule	1
A39	05056108	BLFC Fitting Nut	1
A40	05056086	Screw-M5×30(Hexagon with Washer)	2
A41	05056029	Injector Cover	1

Power Head Exploded View

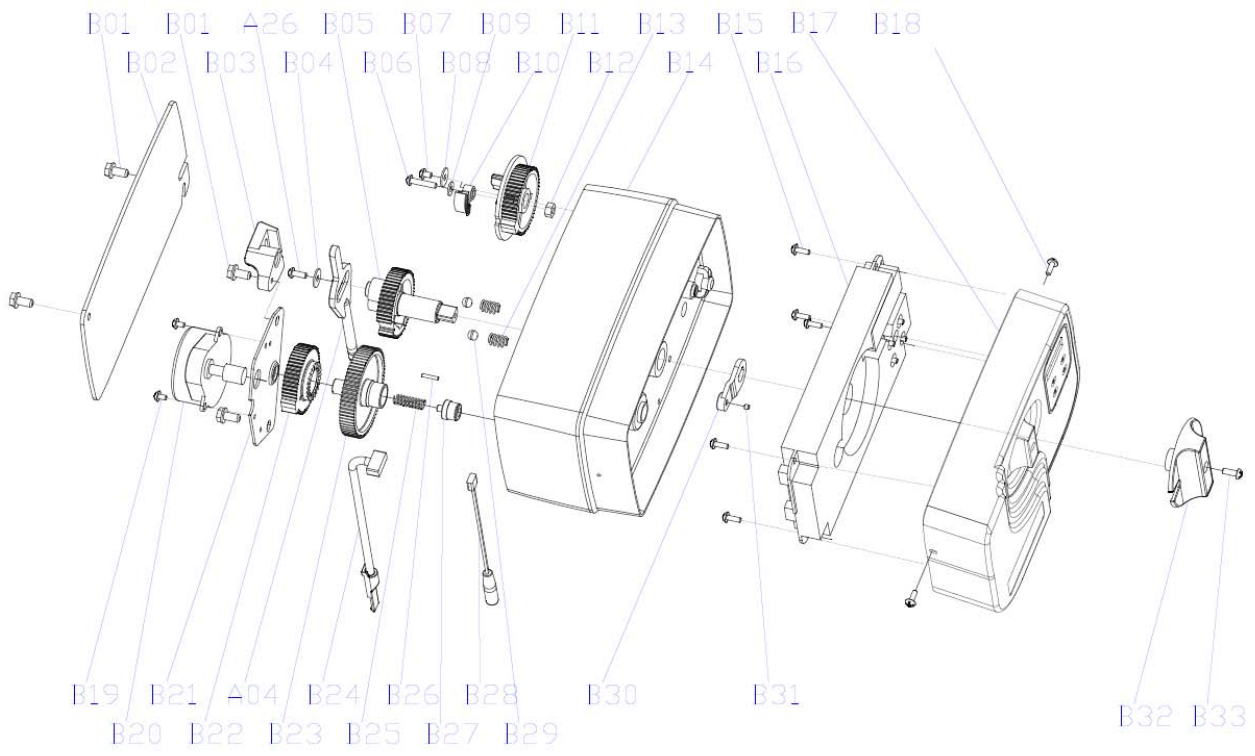

Power Head Parts List

Item No.	Part No.	Part Description	Quantity
B01	5056136	Screw-ST3.5×13(Hexagon with Washer)	4
B02	5056014	Bnt65 Back Cover	1
B03	5010045	Piston Stem Holder	1
A26	13000426	Screw-ST2.9×13(Large Wafer)	1
B04	5056139	Washer-3x13	1
B05	5056005	Main Gear	1
B06	5056083	Screw-M4x14	1
B07	5056166	Screw-ST4.2×12(Large Wafer)	1
B08	5056141	Washer-4x12	1
B09	13111004	Washer-4x9	1
B10	5056016	Refill Regulator	1
B11	5056015	Brine Gear	1
B12	5056089	Nut-M4	1
B13	5056095	Spring Detent	2
B14	5056001	Bnt65 Housing	1
B15	5010037	Screw-ST2.9×10	5
B16	5056504	Bnt165 Pcb	1
B17	5056500	Bnt165 Front Cover	1
	5056505	Bnt165 Operation Label	1
	5056506	Bnt165 Regen. Label	1
B18	5056509	Screw-ST2.9×10(CSK)	2
B19	5056082	Screw-M3×5	2
B20	5056510	Motor-12v/2rpm	1
	11700005	Wire Connector	2
B21	5056045	Motor Mounting Plate	1
B22	5056501	Bnt165 Drive Gear	1
A04	5010081	Bnt65 Piston Rod	1
B23	5056002	Idler Gear	1
B24	5010031	Meter Assembly	1
	5010046	Meter Strain Relief	1
B25	5056094	Spring Idler	1
B26	5056098	Motor Pin	1
B27	5056502	Spring Retainer	1
B28	5056507	Bnt165 Power Cable	1
	5056013	Bnt65 Power Strain Relief	1
B29	5056092	Ball-1/4inch	2
B30	5056503	Magnet Holder	1
B31	5010023	Magnet-φ3×2.7	1
B32	5056008	Bnt65 Knob	1
	5056111	Bnt65 Knob Label	1
B33	5056084	Screw-ST3.5x13	1

Trouble Shooting

Issue	Possible Cause	Possible Solution
A. Unit fails to initiate a regeneration cycle.	1. No power supply.	Check electrical service, fuse, etc.
	2. Defective circuit board.	Replace faulty parts.
	3. Power failure.	Reset time of day.
B. Water is red.	1. By-pass valve open.	Close by-pass valve.
	2. Out of KMnO ₄ .	Add to tank.
	3. Plugged injector / screen.	Clean parts.
	4. Flow of water blocked to chemical tank.	Check for flow to tank.
	5. Rusty water in how water tank. Sediment in tank disturbed.	Repeat flushing of hot water tank required.
	6. Leak between valve and central tube.	Check if central tube is cracked or o-ring is damaged. Replace faulty parts.
	7. Internal valve leak.	Replace valve seals, spacer, and piston
C. Chemical use is high.	1. Defective chemical tank system.	Replace chemical tank.
D. Low water pressure.	1. Iron or scale build up in line	Clean pipes.
	2. Iron build up inside valve or tank.	Clean control and add resin cleaner to clean bed. Increase regeneration frequency.
	3. Inlet of control plugged due to foreign material.	Remove piston and clean control valve.
E. Filter media in drain line.	1. Air in water system.	Check well system for proper air eliminator control.
	2. Incorrect drain line flow control (DLFC) button.	Check for proper flow rate.
F. Too much water in brine tank.	1. Plugged injector or screen.	Clean parts.
	2. Valve not regenerating.	Replace circuit board, motor, or control.
	3. Foreign material in brine valve.	Clean parts.
G. Unit fails to draw regenerate chemicals.	1. Drain line flow control is plugged.	Clean parts.
	2. Injector or screen is plugged.	Clean parts.
	3. Inlet pressure too low.	Increase pressure to 25 PSI.
	4. Internal valve leak.	Replace seals, spacers, and piston assembly.
H. Valve continuously cycles.	1. Defective position sensor PCB.	Replace faulty parts.
I. Flow to drain continuously.	1. Valve settings incorrect.	Check valve settings.
	2. Foreign material in control valve.	Clean control.
	3. Internal leak.	Replace seals, spacers, and piston
J. Pink color in water. Chemical taste.	1. Poor water pressure.	Be sure pump is set to min. 20 psi and is capable of proper flow rate for filter system.
	2. Chemical in supply line.	Decrease frequency of regeneration cycles.

Warranty

Canature WaterGroup warrants that your new water conditioner is built of quality material and workmanship. When properly installed and maintained, it will give years of trouble free service.

Seven Year Complete Parts Guarantee

Canature WaterGroup will replace any part which fails within 84 months from date of manufacture, as indicated by the serial number, provided the failure is due to a defect in material or workmanship. The only exception shall be when proof of purchase or installation is provided and then the warranty period shall be from the date thereof.

Life Time Warranty on Mineral Tanks and Brine Tanks

Canature WaterGroup will provide a replacement mineral tank or brine tank to any original equipment purchaser in possession of a tank that fails provided that the water conditioner is at all times operated in accordance with specifications and not subject to freezing.

General Provisions

Canature WaterGroup assumes no responsibility for consequential damage, labour or expense incurred as a result of a defect or for failure to meet the terms of these guarantees because of circumstances beyond its control.