

# AQUA FLO®

## 1240 Series RO Drinking Water System

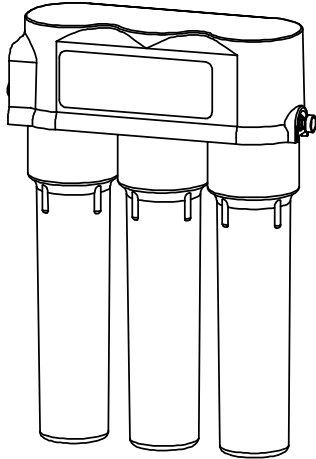

**3VTFC25G  
3VTFC50G**

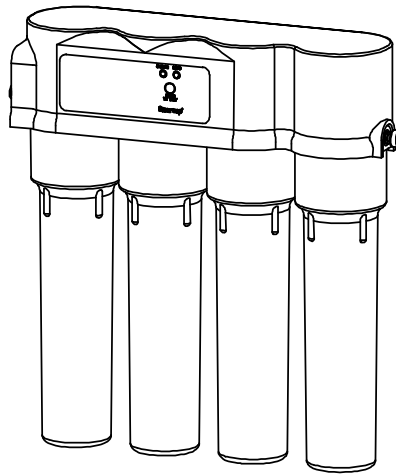

**4VTFC75G-PB**

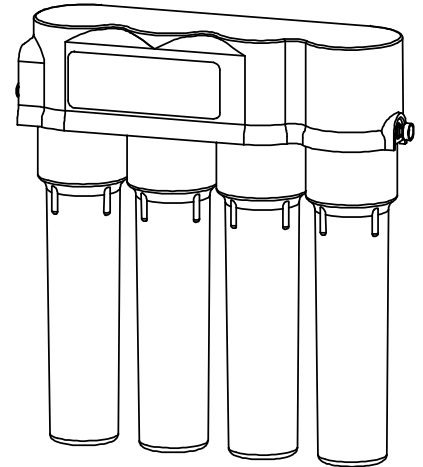

**4VTFC75G**

- Please read carefully before proceeding with installation. Your failure to follow any attached instructions or operating parameters may lead to the product's failure. Keep this Manual for future reference.
- Do not use with water that is microbiologically unsafe or of unknown quality without adequate disinfection before or after the system.
- If you are unsure about installing 1240 RO units, contact Dealer
- Test the water periodically to verify that the system is performing satisfactorily.
- Discard small parts remaining after the installation.
- Failure to install the system correctly voids the warranty.
- Handle all components of the system with care. Do not drop, drag or turn components upside down.
- Be sure the floor under the water filter system is clean, level and strong enough to support the unit.

**BRAND: Aqua Flo 3VTFC25G, 3VTFC50G, 4VTFC75G, 4VTFC75G-PB**

**Canature WaterGroup Canada Inc.**  
855 Park St., Unit 1  
Regina, SK, S4N 6M1  
Toll Free: (877) 288-9888

**Canature WaterGroup U.S.A. Inc.**  
6353 Commerce Drive  
Whitestown, IN, 4607  
Toll Free: (877) 288-9888



# Table of Contents

<b>HOW YOUR SYSTEM WORKS</b>	<b>4</b>
<b>BEFORE YOU START</b>	<b>4</b>
<b>TOOLS NEEDED</b>	<b>5</b>
<b>PARTS OF THE SYSTEM</b>	<b>6</b>
<b>INSTALLING TANK BALL VALVE</b>	<b>7</b>
<b>INSTALLATION REQUIREMENTS</b>	<b>7</b>
<b>COMPONENT LOCATION REQUIREMENTS</b>	<b>7</b>
<b>MAINTENANCE REQUIREMENTS</b>	<b>8</b>
<b>INSTALLING TUBING INTO FITTINGS</b>	<b>8</b>
<b>INSTALL T ADAPTOR VALVE ON WATER SUPPLY</b>	<b>9</b>
<b>ADDITIONAL POINT OF USE CONNECTION</b>	<b>9</b>
<b>DRAIN OUTLET ASSEMBLY INSTALLATION</b>	<b>10</b>
<b>PRODUCT WATER FAUCET SITE PREPARATION</b>	<b>11</b>
<b>FAUCET INSTALLATION</b>	<b>12</b>
<b>AIR GAP FAUCET</b>	<b>13</b>
<b>PARTS LIST</b>	<b>14</b>
<b>ACTIVATING THE SYSTEM</b>	<b>15</b>
<b>CLEANING, SANITIZING, AND CARTRIDGE REPLACEMENT PROCEDURE</b>	<b>16</b>
<b>TROUBLESHOOTING INDICATORS AND COMMON SOLUTIONS</b>	<b>18</b>
<b>WARRANTY</b>	<b>20</b>

# HOW YOUR SYSTEM WORKS

For best results it is recommended to install the R/O on a COLD softened water supply. The 475 Pro Series systems use four stages of treatment to filter your water:

**Stage 1.** Remove sand, dirt, sediment

**Stage 2.** Remove chlorine, taste & odors, very fine particulates

**Stage 3.** Reduce total dissolved minerals

**Stage 4.** Polish water for refined taste

The system is compact and can be installed under the sink or another convenient place close to the faucet.

The closer the proximity to the faucet the better the system flow rate.

## RECOMMENDED FILTER CHANGE SCHEDULE

Your filters require changing on a regular basis. Instructions to change them are on page 8. The schedule below is the minimum recommendation. Depending on your water conditions the filters may need to be changed more often.

Disposable Filters	Change Schedule
Sediment (SED-10)	Every 12 months
Carbon (COC-10)	Every 12 months
Carbon (GAC-10)	Every 12 months
R/O membrane	Every 24-36 months

## BEFORE YOU START

- Your system contains filters which must be replaced periodically for proper operation. (Refer to **Filter Change Schedule above.**)
- Read all steps and guides carefully before installing and using your RO system. Follow all steps exactly to correctly install.
- The system is designed to be used on potable water supplies only. If water is non-potable, additional pre-treatment will be required.
- Do not use for the treatment of water that is visually contaminated (cloudy) or has an obvious contamination source, such as contamination by raw sewage.
- All plumbing should be done in accordance with local codes and requirements.
- Non-Booster pump models work on inlet water pressures of 40 psi (minimum) to 100 psi (maximum). Booster pump models work on inlet water pressures of 30 psi (minimum) to 70 psi (maximum). If your house water pressure is over the maximum, install a pressure reducing valve in the water supply line to the filter system.
- Do not install the system outside, or in extreme hot or cold temperatures. Temperature of the water supply to the R/O system must be between 40°F and 100°F. Do not install on hot water.

FEED WATER GUIDELINES		
	All 1240 Models No Added Booster Pump	All 1240 Models With Added Booster Pump
Maximum TDS	2,000 ppm/mg/l	2,500 ppm/mg/l
Feed Water Pressure	40 to 100 psi	30 to 70 psi
Maximum Hardness	7 GPG	
Maximum Iron	0.2 ppm/mg/l	
Maximum Manganese	0.05 ppm/mg/l	
Maximum Hydrogen Sulphide (H <sub>2</sub> S)	0.00 ppm/mg/l	
Maximum Turbidity	1.0 NTU	
Temperature Range	40° to 100°F (4° to 38°C)	
pH Range	3.0 to 11.0	
Maximum Chlorine	2.0 ppm/mg/l	

**NOTE:** Feed water supply must be potable



# TOOLS NEEDED

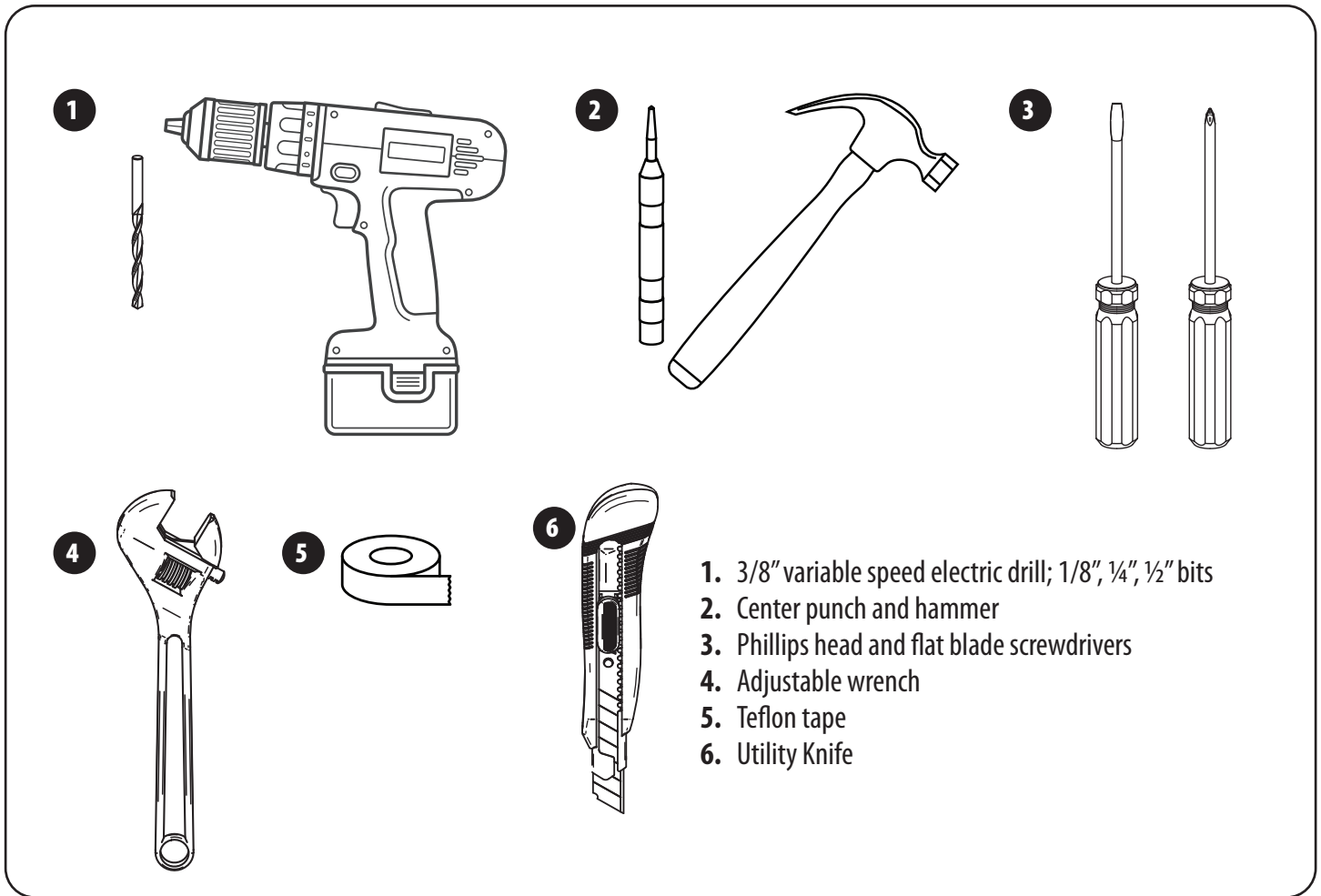

1. 3/8" variable speed electric drill; 1/8", 1/4", 1/2" bits
2. Center punch and hammer
3. Phillips head and flat blade screwdrivers
4. Adjustable wrench
5. Teflon tape
6. Utility Knife

The following components make up your Reverse Osmosis Drinking Water System:

1. **Pre-filter (SED-10)** Pre-filter (SED-10) removes larger particles such as sand, silt, and rust.
2. **Pre-Carbon Filter (COC-10)** removes chlorine in the feed water to protect the reverse osmosis membrane. Optional CB-10 or GAC-10 filter may also be used.
3. **Reverse Osmosis Membrane** reduces dissolved minerals, metals and salts. During the process, harmful compounds are separated by the membrane and the reject water goes to waste (drain).
4. **Post-Carbon Filter (COC-10)** is provided for a final "polish" to provide great tasting drinking water.
5. **Storage Tank (3.0 Gal)** holds filtered water, ready for use.
6. **T Adaptor Valve** is connected to the cold water line to supply water to the RO system.
7. **Faucet (Standard)** used to dispense RO water when needed. **Optional air gap and designer faucets are available.**
8. **Automatic Shut-off Valve** senses when the storage tank is full and closes the water supply to conserve water.
9. **Waste Water Saddle** is connected to the drain to remove reject water from the RO system.

# PARTS OF THE SYSTEM

## SYSTEMS WITH NON-AIR-GAP FAUCET - MODELS 3VTFC25G AND 3VTFC50G SHOWN

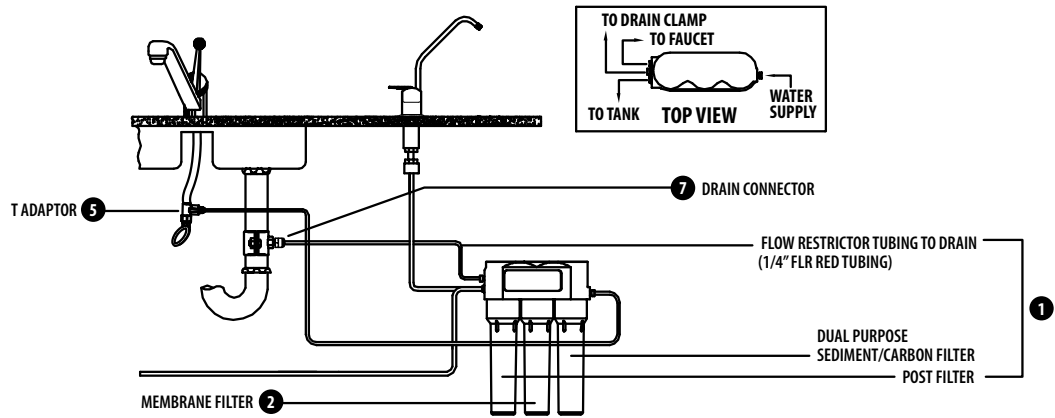

## SYSTEMS WITH AIR-GAP FAUCET - MODELS 3VTFC25G AND 3VTFC50G AND MODELS 4VTFC75G AND 4VTFC75G-PB SHOWN

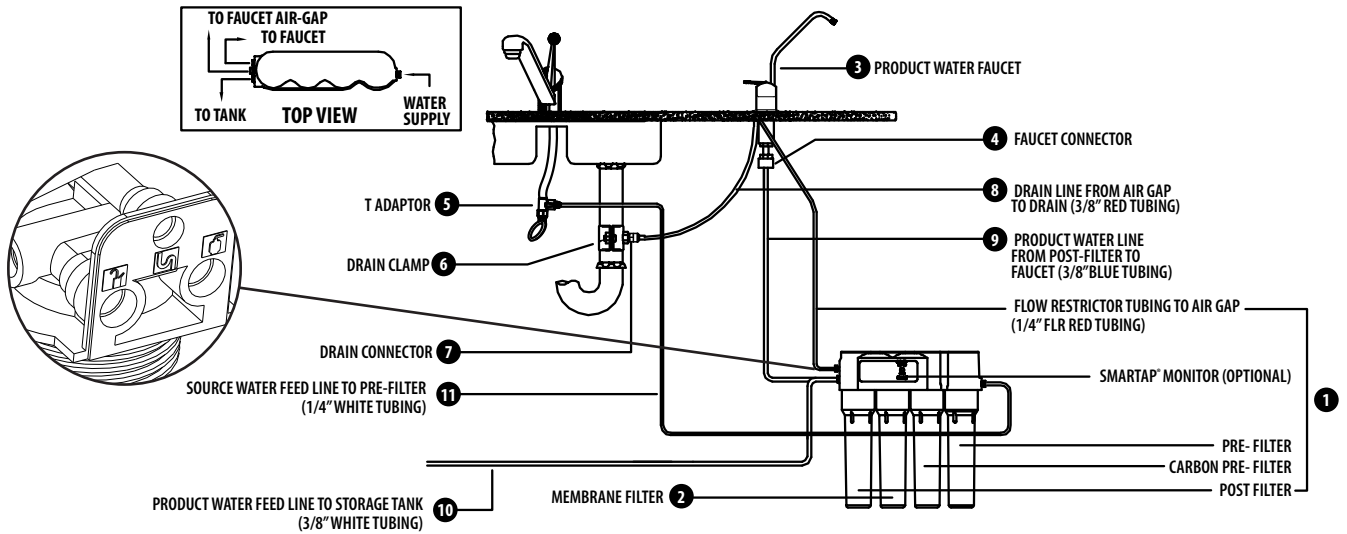

# INSTALLING TANK BALL VALVE

The RO storage tank comes with a 3/8" shut off valve that must be installed.

1. Apply 5-6 wraps of Teflon thread sealant tape to the male thread on the RO storage tank.
2. Install the shut-off valve and tighten until the gasket is compressed.

**NOTE**

While there is a gasket that seals against the shut off valve, it is recommended to still use Teflon tape on the tank threads to insure a good seal is achieved. It is also recommended to check for any leaks after the system has had time to produce water and pressurize inside the storage tank. Failure to do so could result in a leak that is not spotted until after the installer has left the location.

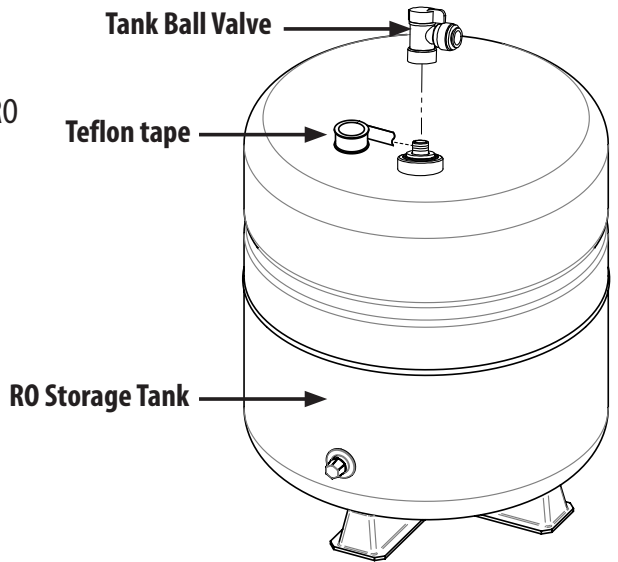

# INSTALLATION REQUIREMENTS

**READ THIS ENTIRE INSTALLATION AND SERVICE GUIDE BEFORE BEGINNING INSTALLATION**

The 1240 Series Reverse Osmosis (RO) Drinking Water Treatment Systems have been designed for ease of installation and serviceability and are constructed with the finest materials available. Using these instructions and paying close attention to the parameters outlined within "CONDITIONS FOR USE" detailed on Page II will ensure a successful installation.

All systems must be installed in accordance with applicable city, state, provincial and local plumbing codes. To ensure a system continues to operate at its optimum level, it is necessary to have a routine maintenance and replacement schedule (Table 4). Frequency at which filters must be changed will depend on quality of feed water supply and level of system usage.

These RO systems contain a replaceable treatment component critical to the efficiency of the system. Replacement of the reverse osmosis component should be with one of identical specification, as defined by Canature WaterGroup™ to assure the same efficiency. Product water shall be tested periodically to verify the system is performing properly.

Operator performs test using the optional Smartap® Water Quality Monitor.

## PREPARATION

1. Check that all appropriate components are packed with your system (Figures 1.A. and 1.B.).
2. Determine locations for RO component installation. Two requirements for consideration are: access to cold water supply line and household sink drainpipe. Specific requirements are detailed in Table 3.

# COMPONENT LOCATION REQUIREMENTS

PRODUCT WATER FAUCET	REVERSE OSMOSIS MODULE
Faucet may be installed in any convenient location. Make sure underside of location is free of obstructions.	Module may be installed under sink or in any convenient location within 15 feet of source water supply and faucet.
STORAGE TANK	
Tank may be placed in any space within 15 feet of faucet, generally under kitchen sink or in an adjacent unused cabinet. Tubing length between components should be kept to a minimum, avoiding sharp bends or kinks.	
<b>DO NOT PLACE MODULE WHERE IT WILL BE EXPOSED TO FREEZING AND/OR DIRECT SUNLIGHT. MODULE MUST BE EASILY REMOVABLE FOR PERFORMANCE OF ROUTINE MAINTENANCE.</b> Mount Module on side of cabinet using bracket (attached to Module) and two screws provided in the Installation Kit. <b>HOLD THE MODULE BY THE FILTER HOUSINGS WHEN PICKING UP OR CARRYING UNIT.</b>	

**CAUTION!**

DO NOT USE WITH WATER THAT IS MICROBIOLOGICALLY UNSAFE OR OF UNKNOWN QUALITY WITHOUT ADEQUATE DISINFECTION BEFORE OR AFTER THE SYSTEM.

**NOTE**

THIS DRINKING WATER SYSTEM IS FOR USE ON POTABLE WATER SUPPLIES ONLY. SOURCE WATER EXCEEDING CHEMICAL PARAMETERS REQUIRES PRE-TREATMENT. COMMONWEALTH OF MASSACHUSETTS PLUMBING CODES 248 CMR SHALL BE ADHERED TO. CONSULT WITH YOUR LICENSED PLUMBER FOR INSTALLATION OF THIS SYSTEM.

# MAINTENANCE REQUIREMENTS

SERVICE REQUIREMENTS	RECOMMENDED SERVICE INTERVALS
To insure the system operates at its optimum level, certain routine maintenance must be performed. Frequency of maintenance performance will depend on feed water quality and level of system usage. <b>CLEAN:</b> Each time filters are replaced <b>SANITIZE:</b> At least once a year and each time membrane is replaced	Replace filters as required or every 6 to 12 months depending on feed water quality. Replace membrane as required based on Smartap® Water Quality Monitor indication or periodic TDS rejection tests. Maximum recommended service life for membrane is 60 months.

## SMARTAP® WATER QUALITY MONITOR

Aquaflo's 12403 Series Reverse Osmosis Systems incorporate a proven performance indicator. Our patented Smartap® Water Quality Monitor uses dual probe LOGIC PULSE MEMORY technology to accurately indicate membrane performance. A split-second power pulse compares feed water Total Dissolved Solids (TDS) level with that of the product water. Then, by reversing the polarity of the electronic pulse, the probes are cleaned and kept free of chemical plating. A nine-volt alkaline battery provides power to the Monitor. For optimum monitor performance, the battery should be replaced each time system is sanitized.

### NOTE

Monitor Troubleshooting Indicators and Common Solutions are shown in Table 5 on Page 13.

## PUSH BUTTON ACTUATED SMARTAP® - 4VTFC75G-PB SERIES

Pressing a test button located on the manifold cover activates monitor. When button is pressed, and momentarily held down, monitor reports membrane status by illuminating a light located next to test button. A green light means system is operating normally. A yellow light indicates system needs servicing (membrane may be depleted or fouled). While the button may be pressed at any time, the most accurate readings are obtained when the system is making water for at least 10 minutes.

# INSTALLING TUBING INTO FITTINGS

- Step 1** Cut the tube square and remove burrs and sharp edges. Ensure that the outside diameter is free from score marks. For soft or thin walled plastic tubing we recommend the use of a tube insert.
- Step 2** Push the tube into the fitting and up to the tube stop.
- Step 3** Pull on the tube to check that it is secure.

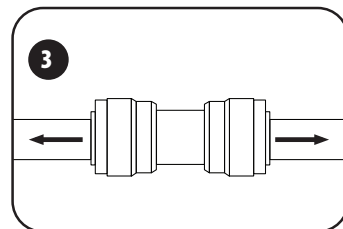
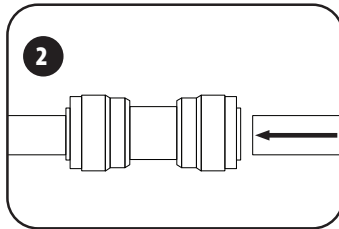
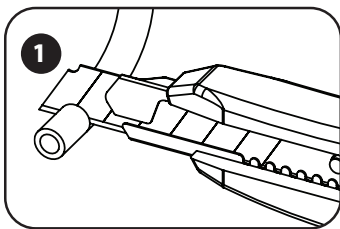

# INSTALL T ADAPTOR VALVE ON WATER SUPPLY

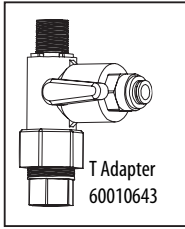

## CAUTION!

The Adapter valve should be connected to cold water supply only. Connection to hot water supply will damage the system and will void all warranty.

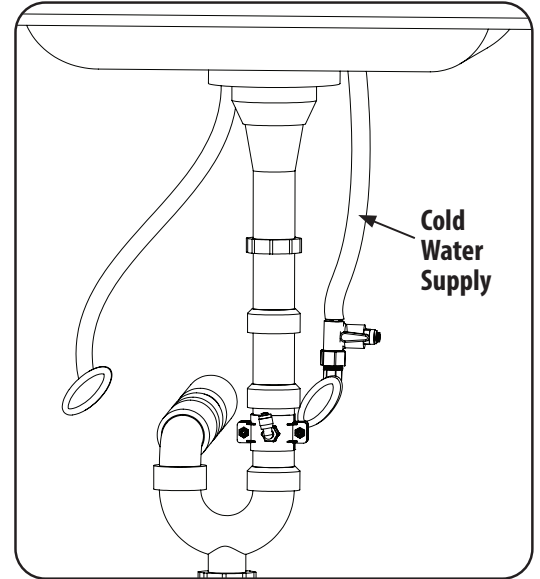
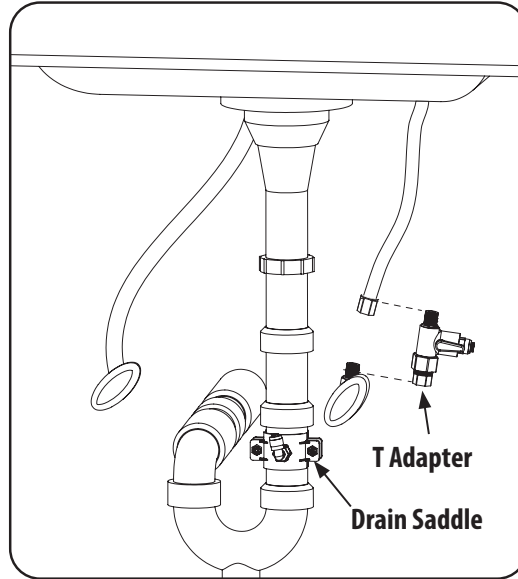

## ADDITIONAL POINT OF USE CONNECTION

1. To connect an additional point of use (icemaker, extra faucet in wet bar and/or another use for treated water), place a "tee" connector (P/N 92403) in 3/8" blue line between faucet and RO Module.
2. Connect "tee" to point-of-use with 3/8" blue tubing (P/N 87600). Connect tubing to point-of-use. Connector requirements are based on type of delivery device i.e., a typical icemaker uses 3/8" x 1/4" reducing device.

## NOTE

Icemakers typically use 1/4" tubing as feed line. Use a reducing union (P/N PI201208S) for this connection.

## NOTE

Reduce the 3/8" Line to 1/4" as close as possible to the additional point-of use device to minimize flow loss.

# DRAIN OUTLET ASSEMBLY INSTALLATION

## NOTE

State, provincial and local plumbing codes may prohibit use of saddle-tapping drain connections and may require use of an air gap.

## NOTE

Location and orientation of drain outlet assembly is vital to system performance.

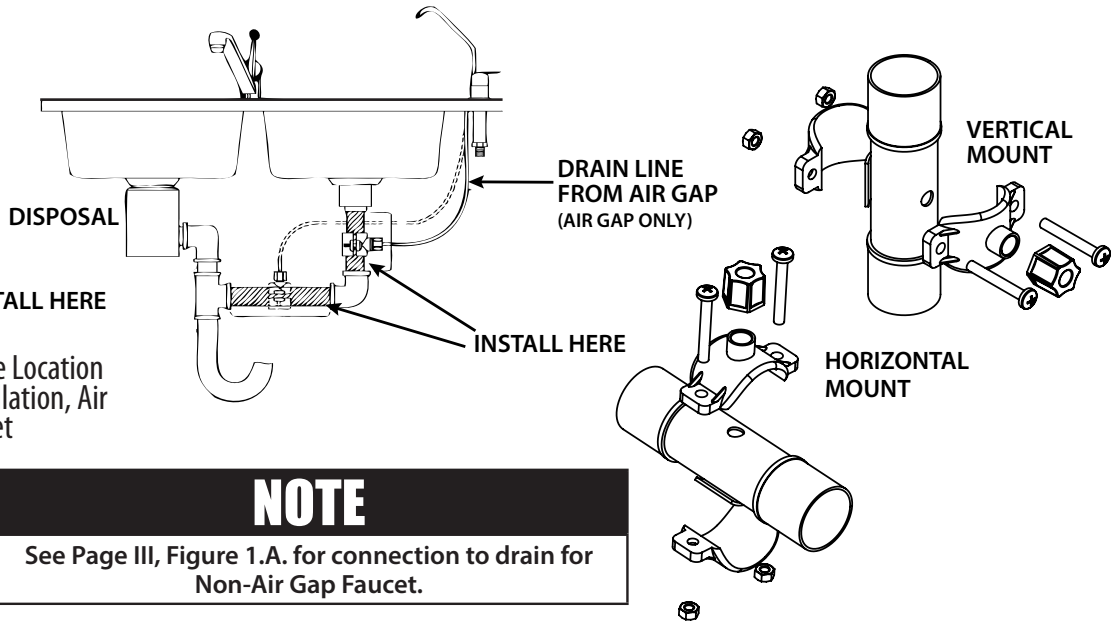

**Figure 4:** Drain Hole Location and Installation, Air Gap Faucet

## NOTE

See Page III, Figure 1.A. for connection to drain for Non-Air Gap Faucet.

### Horizontal Drain Line:

Locate drain hole as close as possible to top of pipe (between 45° and top) and as far as practical from garbage disposal.

### Vertical Drain Line:

Locate drain hole on a straight length of drainpipe next to "P"/"S" trap between trap and sink.

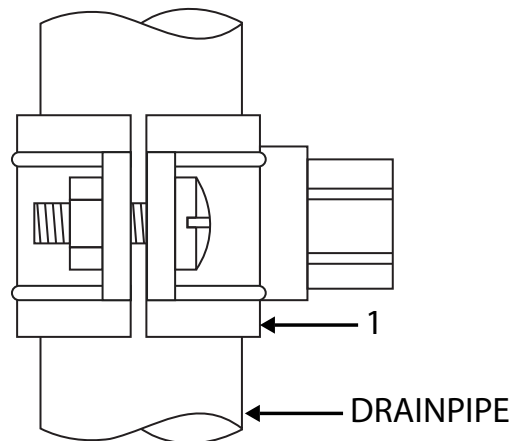

**Figure 5:** Drain Outlet Assembly

## NOTE

Item callouts refer to Figure 5 unless noted otherwise.

Item	Description	Part No.
1	Drain Saddle, Air Gap, 3/8" Connection Drain	92160

# PRODUCT WATER FAUCET SITE PREPARATION

To simplify its access and installation, we suggest you install the faucet on the rear lip of the sink. It should be evenly positioned with the sink faucet and spray attachment. Should the spray faucet hole not be available for the installation, the sink must be drilled.

## Sink Drilling Instructions Stainless Steel Sink

### NOTE

It is recommended retaining the services of a professional counter top craft person when a hole is needed in granite or other specialty counter top materials.

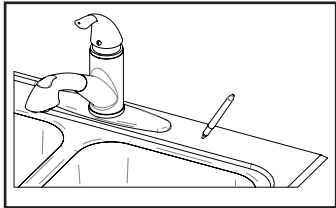

1. Select and mark the proper faucet location.

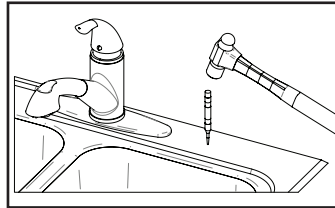

2. Center punch hole to provide a starting point for your drill.

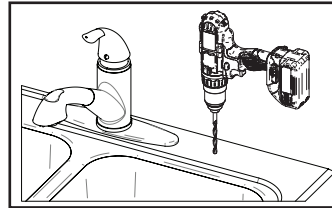

3. Drill a 7/8" hole in the sink using a stepped 7/8" drill bit. If no stepped bit is available, start by drilling a 1/4" hole. Using this hole as a starting point progressively drill larger holes. Increase drill size by 1/8" until you reach a 7/8" hole.

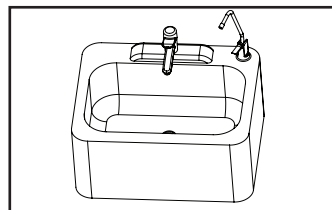
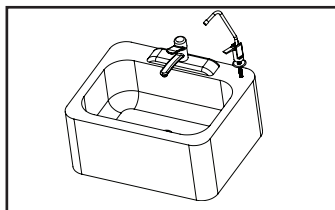
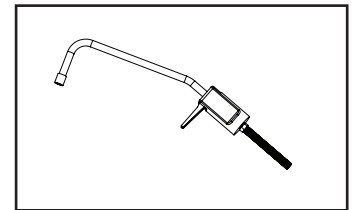
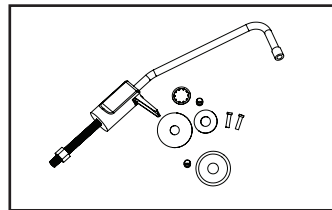
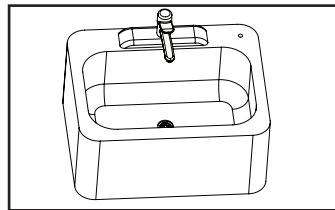
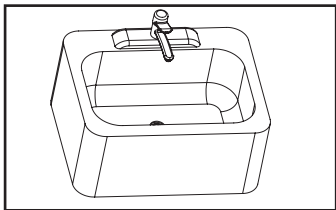

## Porcelain Enamel Sink

Follow these basic guidelines when drilling a porcelain sink:

### Pilot Drill

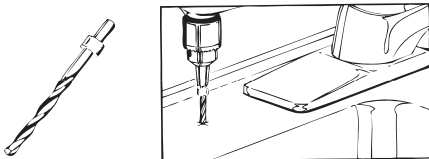

1. Penetrate the porcelain to the base material.

### Spring Loaded Porcelain Saw

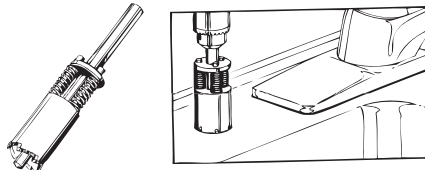

2. Protect the surrounding porcelain material.

### Finish Hole Saw

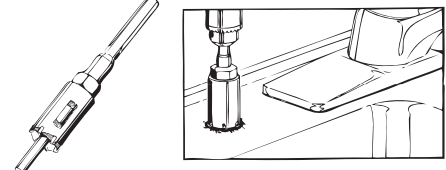

3. Use the appropriate tool to drill the base material.

# FAUCET INSTALLATION

**Figure 5:** Chrome-Plated Metal Product Water Faucet Assembly

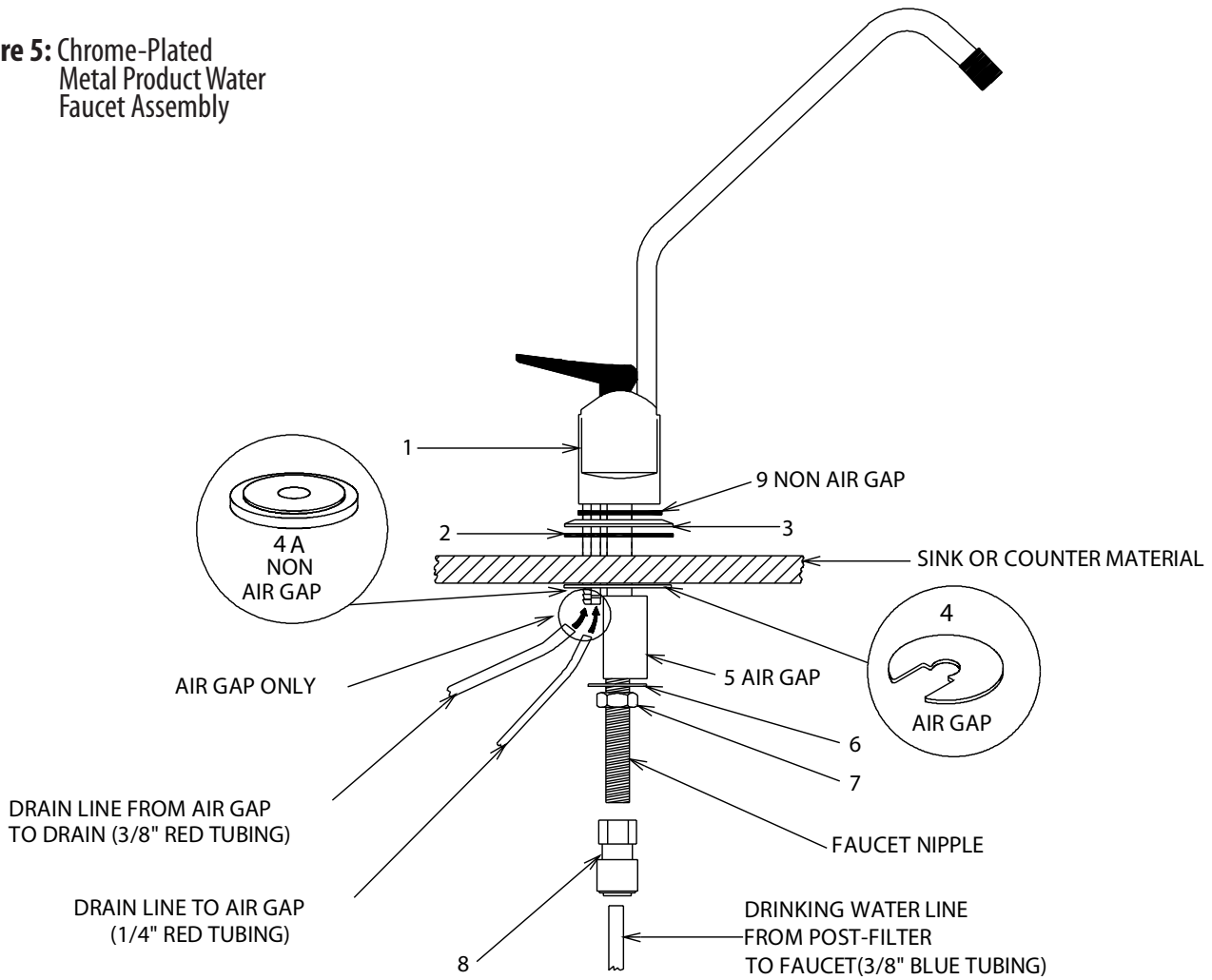

Description	Part No.
Chrome Plated Metal Non-Air Gap Faucet (USEPA Compliant, not available in California)	87511
Chrome Plated Metal Air Gap Faucet (USEPA Compliant, not available in California)	92192

Item	Description
1	Body, Faucet
2	Faucet Base Washer, Rubber
3	Faucet Base Washer, Metal
4	Washer, Slotted (Air Gap, Slot Shape may vary)
4A	Washer, Locating (Non-Air Gap, Replaces Items 4 and 5)
5	Spacer, Faucet (Air Gap)
6	Washer, Faucet
7	Nut, Faucet
8	Connector, Faucet 3/8" x 7/16"
9	Faucet Body Washer, Rubber (Non-Air Gap)

# AIR GAP FAUCET (OPTIONAL - NOT SUPPLIED WITH THIS PRODUCT)

Figure 6

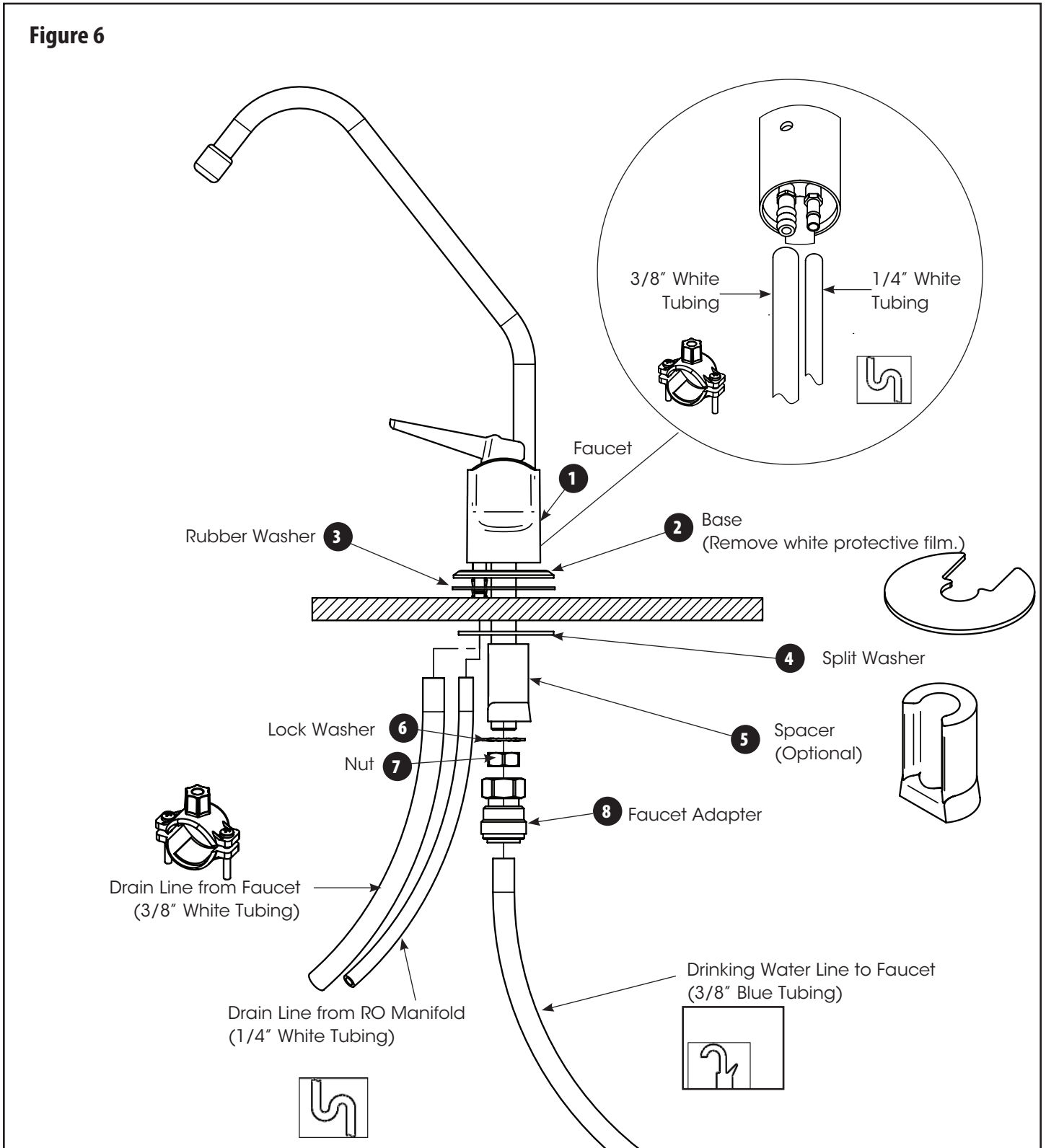

## NOTE

The spacer is required for stainless steel sinks and thin counter tops. If sink is being installed on a thick (5/8" or thicker) counter the spacer is not required.  
Remove white protective film from faucet base.



# PARTS LIST

## MODELS 3VTFC25G 3VTFC50G

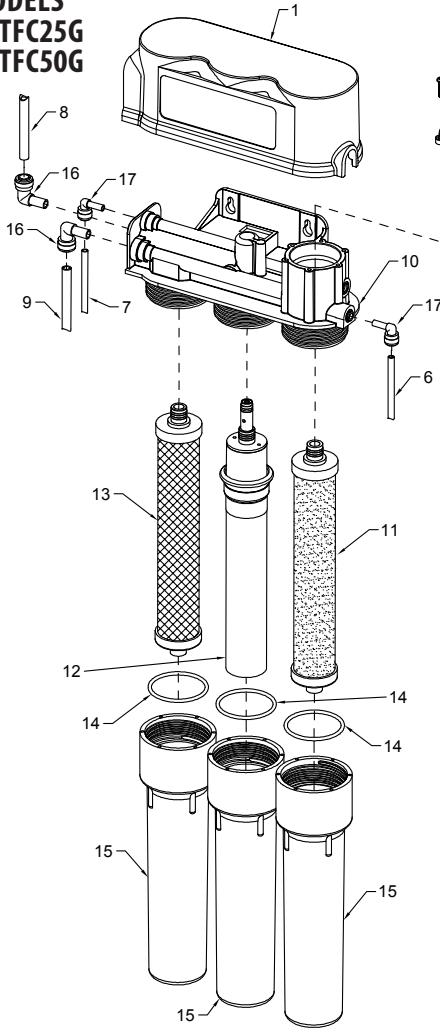

## MODEL 4VTFC75G

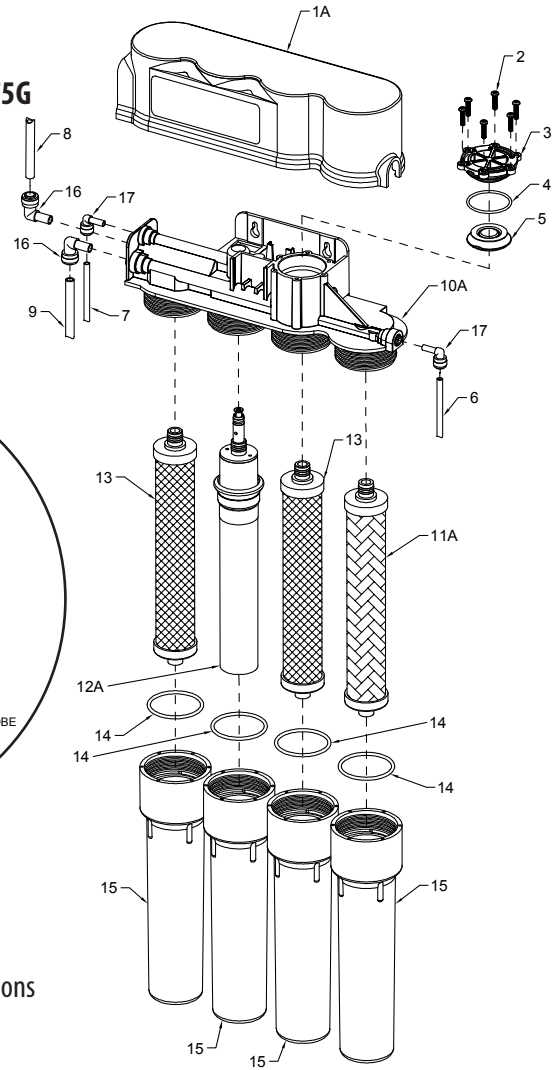

## MODEL 4VTFC75G-PB Push Button Smartap® Monitor Module Cover and Monitor Connections 18. Circuit Board PB 40200132 19. 9 Volt Battery

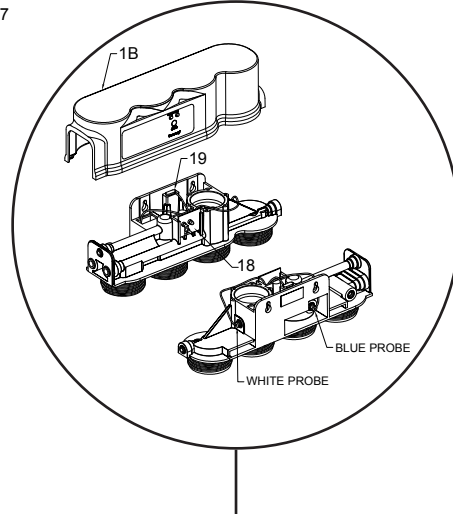

Item	Description	Part No.
1	Cover, 3-vessel Manifold †	20500124
2	Screw, Inlet Valve Cover	20500128
3	Cover, Inlet Valve	
4	"O" Ring, Inlet Valve Cover	
5	Shut Off Assembly	
6	Tubing, 1/4", White *	
7	Flow Restrictor, 1240 Series, Red	
	25 GPD	40600040
	50 GPD	40600041
8	Tubing, 3/8", Blue *	PE-12-EI-0500F-B
9	Tubing, 3/8", White *	PE-12-EI-0500F-W
10	RO, 3V Manifold, Assembled **	124010X0
11	Cartridge, Dual, Sediment/Carbon Filter	41400076
12	Filter, Membrane Thin Film Composite	
	25 GPD, Yellow Casing Black Tape	33001068
	50 GPD, Yellow Casing White Tape	33001033
13	Cartridge, Carbon AES, 10 micron	41400009
14	"O" Ring, Filter Housing	34201026
15	Housing, Filter	20500129
16	Elbow, Stem, 3/8" **	PP221212W
17	Elbow, Stem, 1/4" **	PP220808W

\*Note: These parts are included with installation kit.

\*\*Includes Items: 2, 3, 4, 5.

Item	Description	Part No.
1A	Cover, 4-vessel Manifold †	20500125
1B	Cover, 4-vessel Push Button Manifold †	20500127
2	Screw, Inlet Valve Cover	20500128
3	Cover, Inlet Valve	
4	"O" Ring, Inlet Valve Cover	
5	Shut Off Assembly	
6	Tubing, 1/4", White *	
7	Flow Restrictor, 1240 Series, Red	
	25 GPD	40600040
	50 GPD	40600041
	75 GPD	40600042
8	Tubing, 3/8", Blue *	PE-12-EI-0500F-B
9	Tubing, 3/8", White *	PE-12-EI-0500F-W
10	RO, 4V Manifold, Assembled **	124010X0
11A	Cartridge, Sediment, 5 micron	41400008
12	Filter, Membrane Thin Film Composite	
	15 GPD, Yellow Casing Red Tape	33001071
	25 GPD, Yellow Casing Black Tape	33001068
	50 GPD, Yellow Casing White Tape	33001033
	75 GPD, Yellow Casing Blue Tape	33001056
13	Cartridge, Carbon AES, 10 micron	41400009
14	"O" Ring, Filter Housing	34201026
15	Housing, Filter	20500129
16	Elbow, Stem, 3/8" **	PP221212W
17	Elbow, Stem, 1/4" **	PP220808W

\*Note: These parts are included with installation kit.

\*\*Includes Items: 2, 3, 4, 5.

# ACTIVATING THE SYSTEM



Make sure all water supply lines, drain lines, and fittings are secure and free from leakage.

1. Open source water supply valve. Close product water faucet. Check for leakage.
2. Turn tank valve one-quarter turn counter-clockwise to open valve (handle should be in line with tubing as it enters connection).

### Optional Smartap® Water Quality Monitor

Perform Steps 4 - 7

3. Remove manifold cover if attached by gently lifting cover up and away from manifold.
4. Remove manifold cover if attached by gently lifting cover up and away from manifold.

**CAUTION:** Wiring within module cover connects monitor components. If wires, circuit board, or connections are damaged and/or wetted, monitor will not function.

5. **CAUTION:** Verify battery connector alignment before making connection (Page 12, Figure 9).  
Connect battery on manifold by pressing clip onto battery terminals.
6. Replace manifold cover by gently pushing cover onto manifold until it snaps into place.
7. Test battery connection by activating monitor. Press push button. If either indicator light illuminates, connection is good.

8. Open product water faucet and let water flow until all air has been expelled from system.
9. Close product water faucet. In 30 minutes, check connections for leaks and correct if necessary.

**Icemaker/Extra point of use:** Check connections on these supply lines for leaks.

10. Allow storage tank to fill overnight.
11. **WARNING: DO NOT USE THE FIRST FULL STORAGE TANK OF WATER**

**Icemaker:** Let tray/bin fill with ice cubes. Discard all ice cubes. This flushes sanitizing solution from lines to icemaker.

12. System is ready to use. Should there be any aftertaste or odor to water or ice cubes, repeat Steps 10 and 11.



**DO NOT USE THE FIRST STORAGE TANK OF WATER**  
Allow storage tank to fill overnight. Dispense this water to drain. This process removes factory-installed sanitizing solution from the entire system and sends it to drain. This process also sanitizes fittings and tubing used during installation.

## NOTE

Release button after light illuminates. Test is to confirm battery connection, not water quality.

### RECOMMENDATIONS

HAVE ALL EQUIPMENT AND REPLACEMENT COMPONENTS ON HAND AND READY BEFORE BEGINNING PROCEDURE.  
A CLEAN WORK AREA AND EQUIPMENT ARE ESSENTIAL TO PROPERLY CLEAN AND/OR SANITIZE THE SYSTEM.  
(i.e., CLEAN HANDS, TOOLS, WORK SURFACE, AND CONTAINERS)

### EQUIPMENT NEEDED

Safety glasses Rubber gloves, sanitary Wash Cloth, Clean and Lint-free Liquid dish soap	Household bleach - Unscented Only (5 1/4% sodium hypochlorite) Plastic storage bag Manual Air Pump	Plastic bucket Plastic bowl "O" ring Lube FDA Approved
--	---	--

# CLEANING, SANITIZING, AND CARTRIDGE REPLACEMENT PROCEDURE

1. Mix mild cleaning solution of dish soap and clean potable water in plastic bowl.
2. Empty storage tank and relieve system pressure. Verify tank valve is open. Close feed water supply valve and open product water faucet.  
**Icemaker:** Transfer ice cubes from bin/tray to clean freezer container for storage until procedure is done
3. **CAUTION:** Use air hand pump to avoid damaging tank. Verify product water valve is open before proceeding. Check product water storage tank air pre-charge using a low-pressure gauge (e.g. 0 -15 or 0 – 30 psi). Air valve is located on tank base. Pre-charge should be 55 kPa (8 psig) with tank empty and tank valve open.
4. **CAUTION:** Do not attempt to remove filter housings until water flow stops. This reduces pressure inside the system so housings may safely be removed. **CAUTION:** Additional point-of-use devices (i.e., icemakers) may use filters along their supply line. Remove any filter or treatment device installed between module and device before proceeding. Remove each filter/membrane housing by turning it counter-clockwise. Remove each filter cartridge as its housing is removed. Discard filters.  
**IF MEMBRANE IS PERFORMING SATISFACTORILY: Proceed to Step 5.**  
**IF MEMBRANE IS DEPLETED OR FOULED: Discard it and go to Step 7.**
5. **CAUTION:** Use sanitary rubber gloves for this procedure to avoid contaminating sanitizing solution, filters, or membrane. Wear gloves whenever cleaning/ sanitizing system components or handling new filter/membrane cartridges. Clean membrane outer wrap with washcloth and cleaning solution. Do not immerse membrane in solution. Do not scrub membrane wrap with abrasive cleaners. Rinse membrane well with clean potable water.
6. Place membrane into clean plastic bag, close bag.
7. Remove filter/membrane housing “O” rings and wash them with cleaning solution. Rinse them well with clean potable water. Inspect them for damage (i.e., nicks, scratches). Replace damaged “O” rings.
8. **CAUTION:** Do not get Smartap® Water Quality Monitor electronics, wiring, or connectors wet. Clean filter housings and manifold ports, inside and outside, with washcloth and cleaning solution. Do not use abrasive materials
9. Rinse manifold/housings with clean potable water.
10. Inspect manifold and filter housing “O” ring groove area for damage (i.e., nicks or scratches). Replace damaged components.
11. Place a small amount of “O” ring lubricant over surface of filter/membrane housing “O” ring. Install “O” ring into filter housing groove.  
**TO SANITIZE THE SYSTEM:** Complete Steps 12-34.  
**TO INSTALL FILTERS:** Complete Steps 19-34.  
**WARNING: WEAR SAFETY GLASSES WHILE PERFORMING THIS PROCEDURE.**  
**READ “WARNINGS” INFORMATION ON BLEACH CONTAINER BEFORE USING CONTENTS.**  
**HANDLE SANITIZING SOLUTION CAREFULLY. AVOID CONTACT WITH UNPROTECTED AREAS.**
12. **CAUTION:** Excessive concentrations of bleach will damage plastic and rubber components. Rinse all parts that contact bleach thoroughly with clean potable water. Mix sanitizing solution of 1.5 ml (1/3 teaspoon) of household bleach and 3.8 L (1 gallon) of clean, potable water in the bucket. Mix solution well.
13. **CAUTION:** Tighten filter housings by hand only. Do not use tools as they will over-tighten and damage housings. Take care not to cut or pinch o-rings. Add 236 ml (one cup or 8 oz.) of sanitizing solution to each filter housing and install them onto the manifold (do not install filters or membrane at this time). Tighten each filter housing by hand only.
14. Slowly open source water supply valve.
15. Open product water faucet. Close faucet as soon as water begins to flow from spout.
16. Wait 5 minutes, then close source water supply valve.
17. Wait 25 minutes, then open product water faucet and let water flow to drain.
18. **CAUTION:** Do not attempt to remove filter housings until water flow stops. This reduces pressure inside the system so housings may be removed safely. Remove filter housings and dispose of water. Rinse filter housings and manifold ports thoroughly with clean potable water.

# CLEANING, SANITIZING, AND CARTRIDGE REPLACEMENT PROCEDURE

19. **CAUTION:** Do not remove protective plastic bag from replacement filter/membrane cartridges until so instructed. Install "O" rings into filter housings. Open top of filter bag enough to expose filter cap and "O" ring grooves. Place a small amount of "O" ring lubricant on surface of each "O" ring.
20. **CAUTION:** Tighten filter housings by hand only. Do not use tools as they will over-tighten and damage housings. Take care not to cut or pinch o-rings. **CAUTION:** Refer to Page 8, Figure 8.A., or Page 9, Figure 8.B. for location of each cartridge. Install filter and membrane cartridges. Hold cartridge by its protective plastic bag and insert cartridge into manifold turning it 1/4 turn as it enters the port. Slide bag from cartridge and discard. Replace each filter housing as each cartridge is installed.
21. Turn feed water valve slowly to open position.
22. Confirm system is producing water. Unit will be sending rinse water to drain.  
**TO REPLACE BATTERY: Perform Steps 23 – 29**  
**NOTE:** Replace battery with a new alkaline 9-volt battery.
23. **CAUTION:** Wiring within module cover connects monitor components. If wires, circuit board, or connections are damaged and/or wetted, monitor will not function. Remove module cover by gently lifting manifold cover up and away from manifold body.
24. Disconnect battery. The battery connection is a snap type connector (**Figure 6**).
25. Remove battery by sliding it out of its holder.
26. Slide new battery into its holder.
27. **CAUTION:** Verify battery connector alignment before making connection (**Figure 6**).  
Connect battery by pressing clip onto battery terminals.  
**NOTE:** Release button immediately after light illuminates. Test is to confirm battery connection, not water quality.

28. Test battery connection by activating monitor. Press push button. If an indicator light illuminates, connection is good.
29. Replace manifold cover by gently pushing manifold cover onto manifold until it snaps into place.
30. Open product water faucet. Let water flow until all air has been expelled from the system.
31. Close product water faucet. Wait 30 minutes, check connections for leaks, and correct if necessary.  
**Icemaker/Extra point of use:** Check lines for leaks.
32. Allow storage tank to fill overnight.
33. **WARNING: DO NOT USE THE FIRST FULL STORAGE TANK OF WATER**  
Discard (to drain) first full tank of water by opening product water faucet until water flow stops, then close faucet. This flushes sanitizing solution from system.  
**Icemaker:** Let tray/bin fill with ice cubes. Discard all ice cubes to drain. This flushes sanitizing solution from lines to icemaker. Replace delivery device filter (if applicable).
34. System is ready to use. Should there be any after taste or odor, drain storage tank and repeat **Steps 32 and 33**.

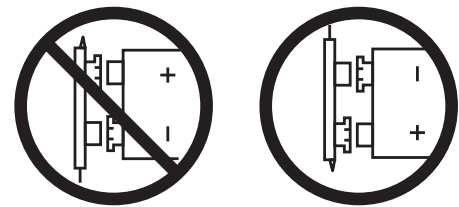

**Figure 6:** Smartap® Battery Connections



## CAUTION!

### DO NOT USE THE FIRST FULL STORAGE TANK OF WATER

Allow reservoir to fill overnight.  
Dispense this water to drain.

This process removes sanitizing solution from system, sanitizes fittings and tubing, and sends solution to drain.

# TROUBLESHOOTING INDICATORS AND COMMON SOLUTIONS

WATER VOLUME AND QUALITY		
SYMPTOM	CONDITION	ACTION
<b>No product water</b>	Water supply is turned off.	Turn on feed water.
<b>Not enough product water</b>	1. Low water pressure.	1. Check source water line pressure.
	2. Water supply is blocked.	2. Clear restriction.
	3. Storage tank valve is closed.	3. Open storage tank valve.
	4. Storage tank is depleted.	4. Increase product water storage capacity and/or install membrane and flow restrictor with higher output rating.
	5. Clogged Pre-filter cartridge(s).	5. Replace Pre-filter cartridge(s).
	6. Storage tank air pressure charge is low.	6. Empty water from storage tank (product water valve must remain open while adjusting pressure) and adjust pressure to 55 kPa (8 psig).
<b>System does not shut off</b>	Shut-off valve is not closing.	Contact your local Dealer.
<b>No drain water</b>	Clogged Flow Restrictor.	Replace Flow Restrictor.
<b>Water has offensive taste and/or odor</b>	1. Carbon post-filter is depleted.	1. Drain storage tank, sanitize system, and replace carbon post-filter cartridge.
	2. Membrane depleted or fouled.	2. Smartap® Monitor reads yellow, or if TDS test is unsatisfactory, drain storage tank, sanitize system, and replace membrane.
	3. Sanitizer not flushed out.	3. Drain storage tank and let it refill overnight.
LEAKAGE AND NOISE		
SYMPTOM	PROBABLE CAUSE	SOLUTION
<b>Leak at fitting</b>	Tubing not pushed completely into fitting. Defective tube.	Push tube into fitting past "O" ring seal. Cut damaged area from tube or replace tube (See Page 2, Figure 2).
<b>Leak at filter housings</b>	1. "O" ring has not seated properly.	1. Remove "O" ring and inspect "O" ring groove for debris. Clean groove, lube, and reseal "O" ring.
	2. "O" ring has nicks or scratches.	2. Replace "O" ring.
<b>Leak from air gap in faucet.</b>	1. Restricted drain tube.	1. Clear restriction.
	2. Obstructed hole in drain clamp	2. Remove obstruction.
	3. Tubing from air gap to drain is routed incorrectly.	3. Reroute tubing so tubing runs vertically with no sharp bends or loops (see Page 4, Figure 4).
<b>Noise from system and/or faucet air gap.</b>	Trapped air in system. Typical of new system or as a result of filter changes.	Nothing, system usage will purge trapped air.
PUSH BUTTON ACTUATED SMARTAP® WATER QUALITY MONITOR		
INDICATION	CONDITION	ACTION
<b>Green Light</b>	System operating normally.	None.
<b>Yellow Light</b>	1. Low or non-usage.	1. Draw enough water from product water faucet to get system into making water. Wait 10 minutes, test.
	2. Membrane depleted or fouled.	2. Clean and sanitize system. Replace membrane.
<b>Dim or No Light</b>	Battery voltage low.	Replace Battery.





## **Aqua Flo® Reverse Osmosis Limited 2 Year Warranty**

Subject to the conditions and limitations described below, Canature WaterGroup™ warrants its AquaFlo® Reverse Osmosis Drinking Water Treatment Systems (excluding membrane and cartridge filters), when installed in accordance with Canature WaterGroup™ specifications, to be free from defects in materials and workmanship under normal use within the operating specifications for a period of two (2) years from the date of purchase (with bill of sale). This warranty shall apply to the original enduser of the system only.

Other than the membrane and cartridge filters, any part found defective within the terms of this warranty will be repaired or replaced by Canature WaterGroup™. If any part is found defective, Canature WaterGroup™ also reserves the right to replace the drinking water appliance with a comparable Canature WaterGroup™ drinking water system of equal or greater quality. You pay only freight for repaired or replaced parts from our factory.

This warranty shall not apply to any part damaged by accident, fire, flood, freezing, Act of God, bacterial attack, membrane fouling and/or scaling, sediment, misuse, misapplication, neglect, alteration, installation, or operation contrary to our printed instructions, or by the use of accessories or components which do not meet Canature WaterGroup™ specifications. If the drinking water system is altered by anyone other than Canature WaterGroup™ the warranty shall be void.

ALL IMPLIED WARRANTIES, INCLUDING WITHOUT LIMITATION WARRANTIES OF MERCHANTABILITY AND FITNESS FOR PARTICULAR PURPOSE, ARE LIMITED TO THE DURATION OF THE PERIOD SPECIFIED ABOVE FOR THE PARTS DESCRIBED IN THIS LIMITED WARRANTY.

As a manufacturer, we do not know the characteristics of your water supply. The quality of water supplies may vary seasonably or over a period of time. Your water usage may vary as well. Water characteristics can also change if the drinking water appliance is moved to a new location. For these reasons, we assume no liability for the determination of the proper equipment necessary to meet your requirements, and we do not authorize others to assume such obligation for us. Further, we assume no liability and extend no warranties, express or implied, for the use of this product with a non-potable water source or a water source which does not meet the conditions for use as described in the Owners Guide.

CANATURE WATERGROUP'S™ OBLIGATIONS UNDER THIS WARRANTY ARE LIMITED TO THE REPAIR OR REPLACEMENT OF THE FAILED PARTS OF THE DRINKING WATER SYSTEM, AND WE ASSUME NO LIABILITY WHATSOEVER FOR DIRECT, INDIRECT, INCIDENTAL, CONSEQUENTIAL, SPECIAL, GENERAL OR OTHER DAMAGES.

**TOLL FREE: 1-877-288-9888**

**[www.canaturewg.com](http://www.canaturewg.com)**