

Econo Flo A10

Air Induction Oxidation Filter

1. This manual contains important safety and operating instructions. Read all instructions and follow them when using this product. Failure to consider this information and follow these instructions, including those concerning maintenance, may result in property damage, injury and or death.

Page 9 contains important information that should be reviewed before installation of this product to ensure proper application.

Page 22 of this manual contains important maintenance procedures for the continued proper operation of your unit. These MUST be performed regularly for your warranty to remain valid.

- 2. We recommend installation only be completed by a competent installer or plumbing professional to insure this product is installed in accordance with local plumbing codes.**
- 3. Read this manual in full and follow all instructions carefully before operation.**
- 4. Avoid pinched O-rings during installation by applying NSF certified lubricant to all seals (provided with install kit).**
- 5. This system is not intended for treating water that is microbiologically unsafe or of unknown quality without adequate disinfection before or after the system.**
- 6. Discard small parts remaining after the installation.**
- 7. Failure to install the system correctly voids the warranty.**
- 8. Handle all components of the system with care. Do not drop, drag or turn components upside down.**
- 9. Save these instructions and keep track of your product's serial number.**

NOTICE: THIS MANUAL CONTAINS A LIMITED WARRANTY. BY INSTALLING AND OR USING THIS PRODUCT, YOU WAIVE CERTAIN LEGAL RIGHTS INCLUDING THE RIGHT TO SUE OR CLAIM COMPENSATION IN THE EVENT OF PROPERTY DAMAGE, INJURY, AND OR DEATH.

Canature WaterGroup Canada Inc.
855 Park St., Unit 1
Regina, SK, S4N 6M1
www.canaturewg.com









Canature WaterGroup U.S.A. Inc.
6353 Commerce Drive
Whitestown, IN, 46075
www.canaturewg.com

Table of Contents

SAFETY	3
FIND AND RECORD VALVE TYPE & SERIAL NUMBERS	4
RECORDS & CONTACTS	4
KNOW THIS BEFORE STARTING YOUR INSTALLATION	5
HOW YOUR WATER FILTER WORKS	7
FEATURES & TERMINOLOGY	7
FLOW RATE INFORMATION	7
CHECK YOUR WATER PRESSURE AND PUMPING RATE	
FEED WATER PARAMETERS	8
BACKWASHING INSTRUCTIONS	9
UNPACKING/INSPECTION	10
BEFORE INSTALLATION	11
PREPARATIONS	12
PLANNING YOUR INSTALLATION	14
INSTALLATION STEPS	16
UNDERSTAND THE SCREEN & KEYPAD CONFIGURATION	18
START-UP INSTRUCTIONS	19
PLUMBING SYSTEM CLEAN UP	21
SYSTEM MAINTENANCE	22
SERVICING YOUR CONTROL VALVE	22
TROUBLESHOOTING GUIDE	25
COMMON SPARE PARTS	27
WARRANTY	28

SAFETY

Throughout this manual, certain conventions are used, including;

HAZARD SYMBOLS	
	For your own safety, please pay strict attention! Examples include: temperature, electrical, and water pressure, etc.
HAZARD SIGNALS	
	Indicates a hazardous situation that, if not avoided will result in death or serious injury, and/or property loss or damage.
	Indicates a hazardous situation that, if not avoided may result in death or serious injury, and/or property loss or damage.
	Indicates a hazardous situation that, if not avoided, could result in a minor or moderate injury, and/or property loss or damage
	Indicates important information, that if not followed may result in damage to equipment, or property loss.
WARRANTY EXCLUSIONS	
	Identify specific instructions that, if not followed, will void the warranty. The warranty provided gives you specific legal rights and otherwise limits your legal rights to the extent permitted by law. By installing and/or using this product, you are accepting these limits on your legal rights.
NOTES	
	Help you take full advantage of the system and are used to emphasize installation, operation, or maintenance information that is important but does not present a hazard.
MANDATORY SIGNS	
	Used to depict a specific behavior that MUST be followed to avoid the present hazard (problem).

Canature WaterGroup U.S.A. Inc. / Canature WaterGroup Canada Inc. (“Canature”) has disclosed all known risks associated with the product within this manual but cannot disclose risks that are beyond its knowledge.

Original instructions. All information, illustrations, and specifications in this manual are based on the latest information available at the time of the publication.

The right is reserved to make changes at any time without notice.

FIND AND RECORD VALVE TYPE & SERIAL NUMBERS

There are two labels located on your Unit: **1) Control valve label** and **2) System number label**. Find and record your product model number, serial number, and valve serial number in the **Records & Contacts** section as they will be important if you need to troubleshoot.



Control Valve Serial # _____

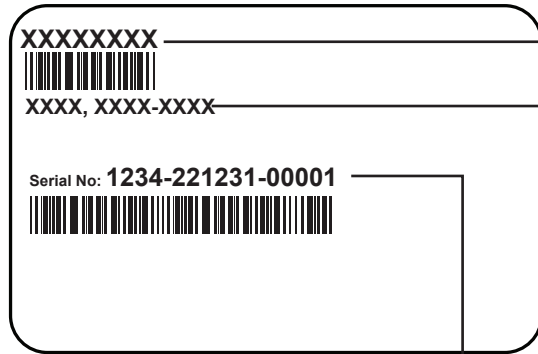

System Serial # _____

Item # _____

Model # _____

NOTE

Do NOT remove or destroy the serial number. It MUST be referenced on request for warranty repair or replacement.

RECORDS & CONTACTS

Please have the information below filled out and available when calling in for parts or warranty:

YOUR DEALER:
Name: _____
Address: _____
Phone: _____
Other: _____
YOUR SYSTEM:
Model number: _____
Serial number: _____
Valve Serial number: _____
Date installed: _____
Installed by: _____
NOTES: _____

KNOW THIS BEFORE STARTING YOUR INSTALLATION

- ▶ Read this manual thoroughly to become familiar with the filter and its capabilities before installing or operating.



Failure to follow instructions could result in personal injury, property damage or death.

This manual will assist you in getting the most out of your new filter.

- ▶ The installation of this filter **MUST** be in accordance with all electrical and plumbing authorities, as well as all applicable local codes and ordinances.

Check with your local public works department for plumbing and sanitation codes.

In the event that the codes conflict with any content in this manual – the local codes should be followed.

Installation by a licensed plumber or certified water treatment professional is recommended.



- ▶ This filter is designed to operate on pressures of 30 -125 psi.

If the water pressure is higher than 125 psi, use a pressure reducing valve ahead of this filter.

- ▶ It is not uncommon for sediment, precipitated iron, or hardness to be present in water supplies. Precipitated minerals or sediment can cause damage to the seals and piston.



If precipitated minerals or sediment are present in your water supply this will be considered a harsh environment. The seals and piston would not be covered by warranty, stated or otherwise.



- ▶ Do NOT use water that is microbiologically unsafe without adequate disinfection before or after this system.

- ▶ This filter is capable of operating at temperatures between 4 °C – 43 °C or (40 °F -110 °F).



Do NOT expose filter to freezing temperatures or vacuum.



- ▶ Do NOT expose filter to direct sunlight.



- ▶ Do not use this filter on hot water supply lines.

- ▶ Avoid pinched O-rings during installation by applying the silicone-based lubricant supplied. Part #92360.

- ▶ It is recommended to inspect and service the control valve on an annual basis.

Cleaning and or replacement of piston, seals, and or spacers may be necessary depending on the raw water quality.

Your installer can provide a maintenance kit for this purpose.

- ▶ Rural applications should have a water analysis annually prior to system checkup or repair.

- ▶ Chlorine bleach and common iron control chemicals may generate toxic fumes when mixed.



- ▶ Always wear appropriate safety gear, such as safety glasses.



NOTICE

The warranty provided gives you specific legal rights and otherwise limits your legal rights to the extent permitted by law. By installing and/or using this product, you are accepting these limits on your legal rights. Canature is NOT responsible for losses, injury, or death resulting from a failure to observe these safety precautions, or misuse or abuse of the equipment.

NOTE

Check with your local public works department for applicable local plumbing and sanitation codes. Follow local codes if they differ from the standards used in this manual. Otherwise, carefully follow the instructions in this manual. Canature is not liable for any non-compliance with local requirements

KNOW THIS BEFORE STARTING YOUR INSTALLATION (CONTINUED)

The AIO all have individual design parameters that must be followed. Please review and verify correct sizing for your application utilizing the chart supplied below and by using the following formula*:

*If your total Iron using the formula below and the number of people line up in a column that shows a Y then your system is sized correctly. If it lines up in a column that shows a N do not install the equipment and review with your supplier to obtain the correctly sized product.

$$(\text{Iron mg/l} \quad \text{X 1}) + (\text{manganese mg/l} \quad \text{X 2}) + (\text{Hydrogen Sulphide mg/l} \quad \text{X 3}) = \text{Total Iron mg/l} \quad \text{_____}$$

AIO Sizing and Application Guide

Chart size is as follows:
100 = 1 Cu.Ft of media
150 = 1.5 Cu.Ft of media
200 = 2 Cu.Ft of media
250 = 2.5 Cu.Ft of media
300 = 3 Cu.Ft of media

# persons in the home	Model Size	Total Iron MG/L from calculation													
		1	2	3	4	5	6	7	8	9	10	15	20	25	30
1	100	Y	Y	Y	Y	Y	Y	Y	Y	Y	Y	Y	Y	Y	Y
1	150	Y	Y	Y	Y	Y	Y	Y	Y	Y	Y	Y	Y	Y	Y
1	200	Y	Y	Y	Y	Y	Y	Y	Y	Y	Y	Y	Y	Y	Y
1	250	Y	Y	Y	Y	Y	Y	Y	Y	Y	Y	Y	Y	Y	Y
1	300	Y	Y	Y	Y	Y	Y	Y	Y	Y	Y	Y	Y	Y	Y
2	100	Y	Y	Y	Y	Y	Y	Y	Y	Y	Y	N	N	N	N
2	150	Y	Y	Y	Y	Y	Y	Y	Y	Y	Y	N	N	N	N
2	200	Y	Y	Y	Y	Y	Y	Y	Y	Y	Y	Y	N	N	N
2	250	Y	Y	Y	Y	Y	Y	Y	Y	Y	Y	Y	Y	Y	N
2	300	Y	Y	Y	Y	Y	Y	Y	Y	Y	Y	Y	Y	Y	N
3	100	Y	Y	Y	Y	Y	Y	Y	Y	Y	N	N	N	N	N
3	150	Y	Y	Y	Y	Y	Y	Y	Y	Y	N	N	N	N	N
3	200	Y	Y	Y	Y	Y	Y	Y	Y	Y	N	N	N	N	N
3	250	Y	Y	Y	Y	Y	Y	Y	Y	Y	Y	N	N	N	N
3	300	Y	Y	Y	Y	Y	Y	Y	Y	Y	Y	N	N	N	N
4	100	Y	Y	Y	Y	Y	Y	Y	N	N	N	N	N	N	N
4	150	Y	Y	Y	Y	Y	Y	Y	Y	N	N	N	N	N	N
4	200	Y	Y	Y	Y	Y	Y	Y	Y	Y	N	N	N	N	N
4	250	Y	Y	Y	Y	Y	Y	Y	Y	Y	N	N	N	N	N
4	300	Y	Y	Y	Y	Y	Y	Y	Y	Y	N	N	N	N	N
5	100	Y	Y	Y	Y	Y	Y	N	N	N	N	N	N	N	N
5	150	Y	Y	Y	Y	Y	Y	N	N	N	N	N	N	N	N
5	200	Y	Y	Y	Y	Y	Y	Y	Y	N	N	N	N	N	N
5	250	Y	Y	Y	Y	Y	Y	Y	Y	Y	N	N	N	N	N
5	300	Y	Y	Y	Y	Y	Y	Y	Y	Y	N	N	N	N	N
6	100	Y	Y	Y	Y	Y	N	N	N	N	N	N	N	N	N
6	150	Y	Y	Y	Y	Y	N	N	N	N	N	N	N	N	N
6	200	Y	Y	Y	Y	Y	Y	Y	N	N	N	N	N	N	N
6	250	Y	Y	Y	Y	Y	Y	Y	Y	N	N	N	N	N	N
6	300	Y	Y	Y	Y	Y	Y	Y	Y	N	N	N	N	N	N



HOW YOUR WATER FILTER WORKS

AIO systems work by passing incoming water through a captive air bubble in a separate tank. The water is then passed through a special filter bed.

As more water passes through this iron filter, the oxygen in the air bubble is used up, and the media gets loaded with iron. The regeneration process then begins in order to replenish the supply of oxygen, and to backwash the precipitated iron trapped in the media bed.

FEATURES & TERMINOLOGY

Time

This is set for your current time of day.

Gallons Remaining or Days Remaining

This shows gallons or days left before a regeneration cycle.

Number of People

Living in the household as programmed during installation. The installer usually sets this for the worst case hardness.

Reserve Capacity

Calculated at seventy-five (75) gallons per person.

Manual Regen Delay

Generally used after servicing the valve so that it will regenerate at the standard preset regeneration time.

Manual Regeneration

To regenerate immediately, turn the center knob clockwise to BA. WA (Backwash) position.

Regen Time

Time of day that the softener is scheduled to regenerate.

FLOW RATE INFORMATION

At the stated service flow rates, the pressure drop through these devices will not exceed 15 psig.

Peak flow rates are intended for intermittent use only (10 minutes or less) and are for residential applications only. Do not use peak flow rate for commercial applications or for a continuous rate when treated water supplies are geothermal heat pump, swimming pool, etc.

For satisfactory operation, the pumping rate of the well system must equal or exceed indicated backwash flow rate.

CHECK YOUR WATER PRESSURE AND PUMPING RATE

Two water system conditions must be checked carefully to avoid unsatisfactory operation or equipment damage:

1. Minimum water pressure required at the filter tank inlet is 20 psi.
2. The pumping rate of your well pump must equal or exceed the indicated backwash flow rate of your unit.
To measure the pumping rate of your pump, follow these instructions:
 - a. Make certain no water is being drawn. Open spigot nearest pressure tank. When pump starts, close spigot and measure time (in seconds) to refill pressure tank (when pump shuts off). This figure represents cycle time.
 - b. With the pressure tank full, draw water into a container of known volume, and measure the number of gallons drawn until the pump starts again. This is draw-down. Divide this figure by cycle time and multiply the result by 60 to arrive at the pumping rate in gallons per minute (gpm). To aid in your calculation, insert the date in the following formula:

DRAW-DOWN _____ ÷ **CYCLE TIME** _____ x 60 = **PUMPING RATE** _____ (gpm)

EXAMPLE: CYCLE TIME is 53 secs.; DRAW-DOWN is 6 gals.; then, PUMPING RATE equals:

6 gals. ÷ 53 secs. x 60 = 6.8 gpm

NOTE

If your pumping rate is inadequate, do not install your filter until problem is corrected.



CHECK YOUR WATER PRESSURE AND PUMPING RATE

(CONTINUED)

BACKWASH FLOW RATES

The most important criteria in sizing a filter is the capacity of the pump. The water must pass through the filter media at a service flow rate that allows it to operate properly. The filter must also be backwashed at a flow rate sufficient to dislodge and remove captured particulates. Failure to provide sufficient water will cause a build-up of particulates in the filter media, impairing its filtration ability. In order for your filter to backwash and rinse properly, your pump must be capable of providing the backwash flow rates indicated in the above specification chart.

FEED WATER PARAMETERS

Make sure you have a copy of your most recent water test results. If your water has not been tested previously, your professional installer can obtain a water sample bottle to be sent to one of our facilities for a free analysis. **It is important that this product not be installed until you have this information.**

The AIO filters all have individual design parameters that must be followed.

ALL UNITS

Maximum TDS = 2000 ppm

Maximum Sulphates = 500 ppm

Maximum Hardness = 75 gpg

Maximum Tannin = 0.0 ppm

A10M

Maximum Iron = 30 ppm ferrous or ferric

Maximum Manganese = 1.0 ppm

Maximum Hydrogen Sulfide = 3.0 ppm

pH = 6.5 to 7.5

A10

Maximum Iron = 30 ppm ferrous or ferric

Maximum Manganese = 0.0 ppm

Maximum Hydrogen Sulfide = 1.0 ppm

pH = 7.0. to 8.5

A10C (Catalytic Carbon)

Maximum Iron = 0.0 ppm ferrous or ferric

Maximum Manganese = 0.0 ppm

Maximum Hydrogen Sulfide = 5.0 ppm

pH = 7.0. to 8.5

Standard Chemfree Filter (A10 Models)

This special media not only increases the pH of the water to enhance iron, manganese and hydrogen sulfide removal but also acts as a physical barrier to trap iron precipitate.

The filter will automatically adjust the pH to neutral or higher on acid water without an acid neutralizer. The ability to raise pH greatly enhances the filter's ability to remove iron efficiently.

Replenishment of the media that raises pH will be required periodically, depending on how low the raw water pH is the amount of manganese (Mn) present in the water and usage rate.

Carbon Filter (A10C Models)

The Hydrogen Sulfide reduction filter combines aeration with catalytic carbon technology to effectively reduce sulfur from water.

BACKWASHING INSTRUCTIONS

BACKWASH FREQUENCY

This unit is factory set for backwash every 4 days. More frequent backwash may be required based on water conditions and amount of water used.

Instructions for Chart Use

From your water test results add the following together: **Iron ppm plus manganese mg/l x 2 plus Hydrogen sulfide ppm x 3. EG 1ppm plus .5 x 2 = 1.0 plus .5 x 3= 1.5** will give you a compensated iron amount of **3.5** locate **3.5** (round up) on the chart if assuming it fits into the area that is shaded with a **Y** in it then the unit is sized correctly. Factory setting is **600 gallons** or **4 days** between regenerations. Please adjust gallons accordingly, do not adjust the day setting as the unit is required to regenerate at least every **4 days** to replenish the air pocket in the air tank. Should the compensated iron fall into the area shown with an **N** please contact your sales representative for additional information before installation.

(Iron mg/l _____ X 1) + (manganese mg/l _____ X 2) + (Hydrogen Sulphide mg/l _____ X 3) = Total Iron mg/l _____

		ppm compensated iron	1	2	3	4	5	6	7	8	9	10	15	20	25	30
People in home	Total Gallons available	3200	1600	1050	800	650	500	450	400	350	300	200	150	100	100	
1		Y	Y	Y	Y	Y	Y	Y	Y	Y	Y	Y	Y	Y	Y	Y
2		Y	Y	Y	Y	Y	Y	Y	Y	Y	Y	Y	N	N	N	N
3		Y	Y	Y	Y	Y	Y	Y	Y	Y	Y	N	N	N	N	N
4		Y	Y	Y	Y	Y	Y	Y	N	N	N	N	N	N	N	N
5		Y	Y	Y	Y	Y	Y	N	N	N	N	N	N	N	N	N
6		Y	Y	Y	Y	Y	N	N	N	N	N	N	N	N	N	N

Note importance of pH in application and setting of your equipment

While the AIO product does have the ability to stabilize and in fact raise the PH some this is not always enough to complete the oxidation process.

If your raw pH is between 7.0 and 7.3 the effective oxidation time is cut in half so please set the unit accordingly (half the amount of gallons noted on the chart)

If the Raw pH is between 6.8 to 7.0 the effective oxidation time is cut by .75 so please set the unit accordingly (1 quarter the amount of gallons noted on the chart)

if the Raw pH is lower than 6.8 additional pH correction measures will need to be taken please contact your representative.

UNPACKING/INSPECTION

Be sure to check the entire unit for any shipping damage or parts loss. Also note damage to the shipping cartons. Contact the transportation company for all damage and loss claims. The manufacturer is not responsible for damages in transit.

Small parts, needed to install the filter, are in a parts box. To avoid loss of the small parts, keep them in the parts bag until you are ready to use them.

What is included in the box?

For Models AIO75, AIO10 and AIO15, you will expect the following. Shipping Carton Quantity – 1

1. Control Valve
2. Tank
3. Parts Box
4. Owners Manual
5. Drain Hose & Clamp

There are 7 Red clips. Please check to make sure you have all of them.

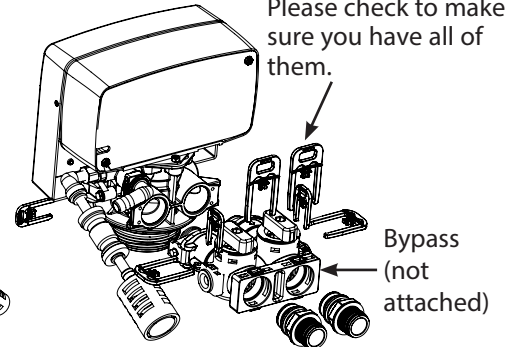

1. Control Valve

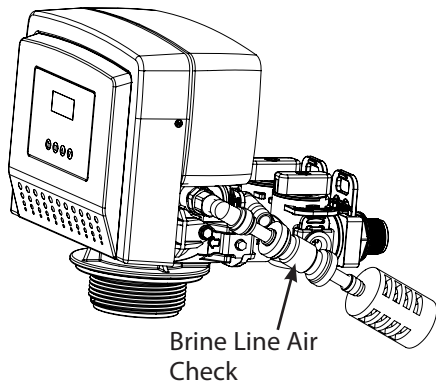

2. Tank

3. Parts Box

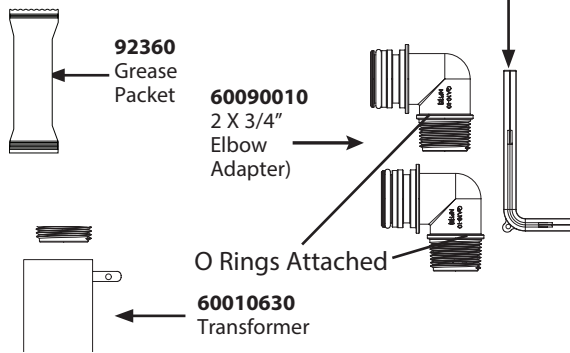

Distributor Tube Inside the Tank

Media Inside the Tank. Media Type will depend on what models were purchased

BEFORE INSTALLATION

Make sure you have a copy of your most recent water test results. If your water has not been tested previously, your professional installer can obtain a water sample bottle to be sent to one of our facilities for a free analysis. **It is important that this product not be installed until you have this information.**

In all cases where metal pipe was originally used and is later interrupted by poly pipe, or the Noryl bypass valve, an approved ground clamp with physical separation and no less than #6 copper conductor must be used for continuity, to maintain proper metallic pipe bonding.

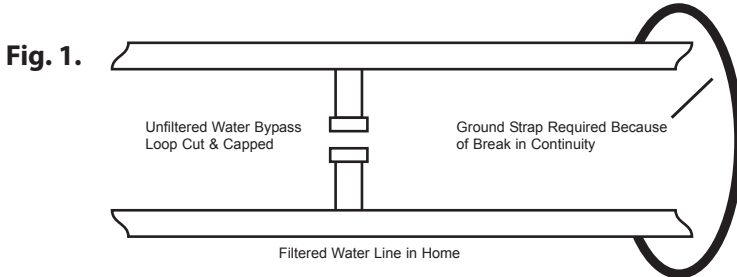

WARNING

If the ground from the electrical panel or breaker box to the water meter or underground copper pipe is tied to the copper water lines and these lines are cut during installation of the bypass valve and/or poly pipe, an approved grounding strap must be used between the two lines that have been cut in order to maintain continuity. The length of the grounding strap will depend upon the number of units being installed and/or the amount of copper pipe being replaced with plastic pipe.

See Figure 1.

MECHANICAL

Do NOT use petroleum-based lubricants such as petroleum jelly, oils or hydrocarbon based lubricants. Use only 100% silicone lubricants (packet Part #92360 provided in parts kit). All plastic connections should be hand tightened only. Thread tape may be used on connections that do not use an O-ring seal.

Do NOT use pliers or pipe wrenches except when indicated by nut shape, e.g., pipe adapters. All plumbing must be completed according to local codes. Soldering connections should be done before connecting any plastic pieces to the pipe as excessive heat can damage them.

TOOLS REQUIRED FOR INSTALLATION

- ▶ Two adjustable wrenches.
- ▶ Additional tools may be required if modification to home plumbing is required.
- ▶ Plastic inlet and outlet fittings are included with the filter. To maintain full valve flow, use of $\frac{3}{4}$ " or 1" [1.9 cm or 2.54 cm] pipes to and from the filter. You should maintain the same or larger pipe size as the water supply pipe to the filter inlet and outlet.
- ▶ Use copper, brass, or PEX pipes and fittings.
- ▶ Some codes may also allow PVC plastic pipe.
- ▶ $\frac{5}{8}$ " [15.8 mm] Outside Diameter drain line is needed for the valve drain.
- ▶ Drain line tubing may be needed for the optional brine tank overflow fitting.

NOTE

Use of a competent installer or plumbing professional to ensure this product is installed in accordance with local plumbing codes is recommended. Canature is not liable for any non-compliance with local requirements.

PREPARATIONS

MEDIA INSTALLATION

Follow the steps below for proper media loading.

1. Temporarily plug the open end at the top of the distributor tube with tape.

Plug the Distributor Tube

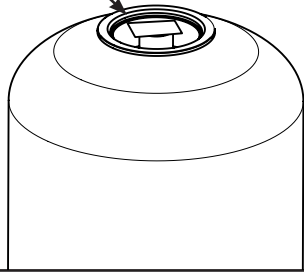

2. Ensure the bottom of the distributor tube remains seated in the depression at the bottom of the tank. Fill tank one-quarter full with water to protect the distribution tube during gravel installation.

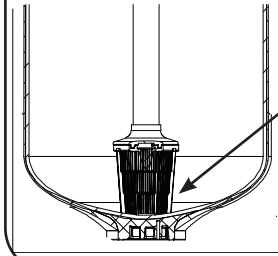

The distributor remains inside the tank seated in the depression at the bottom

3. Fill the gravel support bed first. A large funnel makes filling the tank much easier. Order part #99003 separately for your own funnel. Slowly add the gravel. Depending on the type of system, add the resin, or media next.

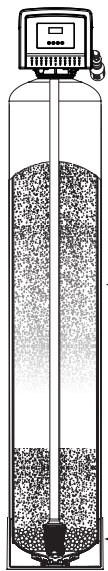
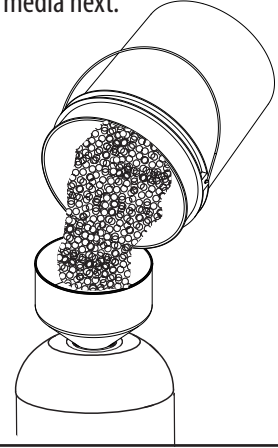

AIO/AIOM Models

← Calcium Carbonate & Magnesium Oxide Mixed Filter Sand

← Support Bed Gravel

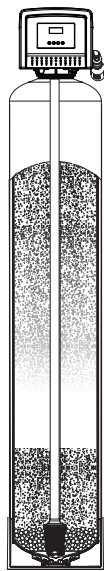

AIOC Models

← Carbon

← Support Bed Gravel

Fill tank one quarter full of water to protect distribution during gravel installation.

Place the media into the tank in the order indicated above. Slowly and carefully add the gravel support bed and the filtration media leveling each layer as it is placed into the tank.

NOTE

If severe loss in water pressure is observed when the filter unit is initially placed in service, the filter tank may have been laid on its side during transit. If this occurs, backwash the filter to 'reclassify' the media.



MANDATORY



Wear a Dust Mask. Airborne particles could pose potential health risks.

PREPARATIONS (CONTINUED)

4. Apply the supplied lubricant (part #92360) to the internal O-ring at the bottom of the control valve. Apply lubricant to the larger O-ring on the bottom of the valve that seals with the tank threads.

Internal O-ring

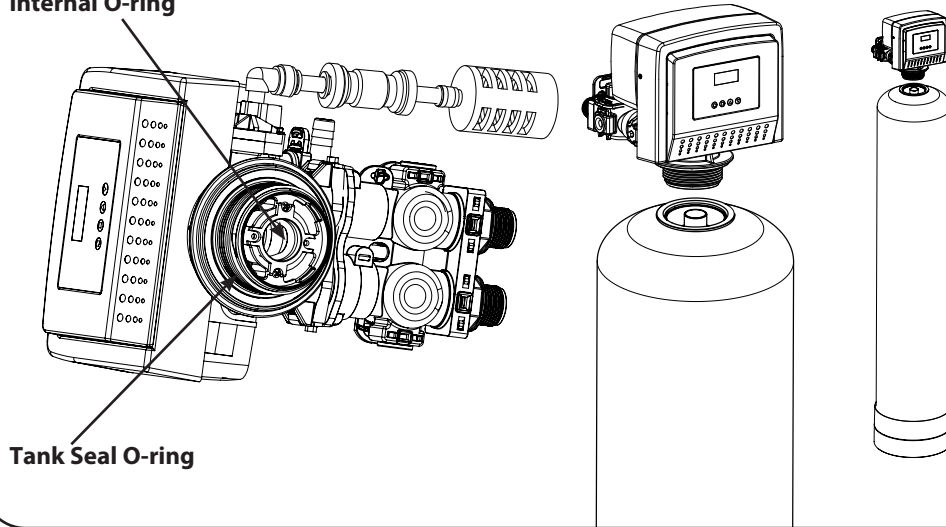

Tank Seal O-ring

NOTICE

Do NOT use petroleum-based lubricants as they will cause swelling of the O-ring seals.

5. Remove the tape from the top of the riser tube. Carefully position the valve over the riser tube, inserting riser into the internal O-ring. Turn the valve clockwise into the threads of the tank until secure.

Unscrew Spill Cap
D-Tube

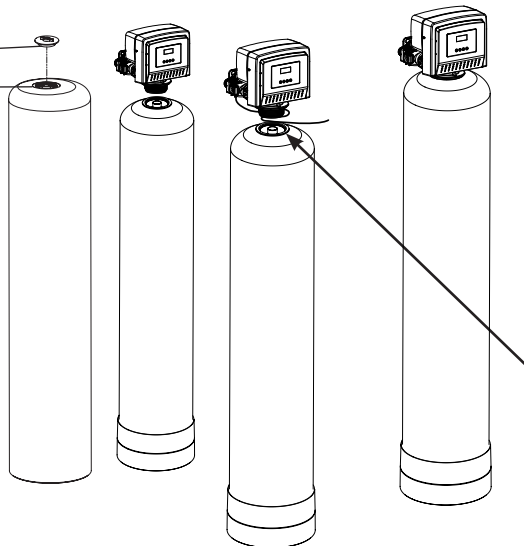

NOTICE

Make sure the quick connect power cord is not yet connected to prevent the cord getting caught between the threads of the tank and the valve.

PLANNING YOUR INSTALLATION

WATER FILTER INSTALLATION LAYOUT

Select the location for your filter tank with care. Various conditions that contribute to proper location include:

1. All installation procedures must conform to local or regional plumbing codes. Canature is not liable for any non-compliance with local requirements
2. Outside taps used to water lawns and gardens should be isolated from the water line required to supply untreated water to the inlet of the water filter – a separate (new) line may be needed.
3. Where required by local plumbing codes, a check valve may need to be installed. Canature is not liable for any non-compliance with local requirements
4. Locate filter as close as possible to the water supply source.
5. Locate filter as close as possible to a floor or laundry tub drain and a 120 volt AC electrical outlet.
6. Filters should be located before the water heater on the supply line. If closer than three (3) metres [10 feet], install a check valve in accordance with local plumbing codes.
7. Do NOT install a filter in a location where freezing temperatures occur. Freezing may cause permanent damage to this type of equipment and will void the factory warranty. Freezing could also result in flooding and / or property loss and damage.
8. Allow sufficient space around the unit for easy servicing.
9. Keep the filter out of direct sunlight.

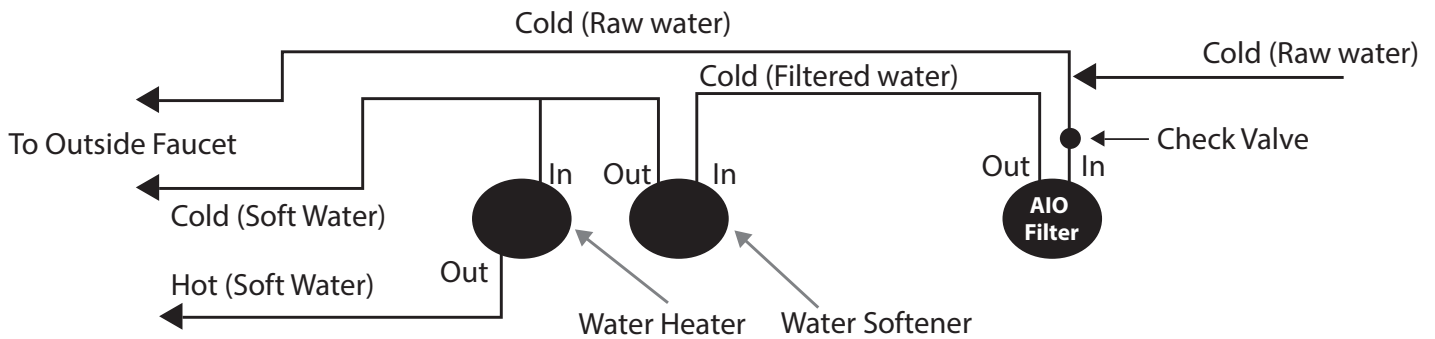

*NOTE

Check local plumbing codes requirements for use of check valve(s), back-flow prevention, or vacuum breakers. Canature is not liable for any non-compliance with local requirements.

PLANNING YOUR INSTALLATION (CONTINUED)

WATER FILTER INSTALLATION

NOTE

Check valve needs to be installed on the inlet side of the system.

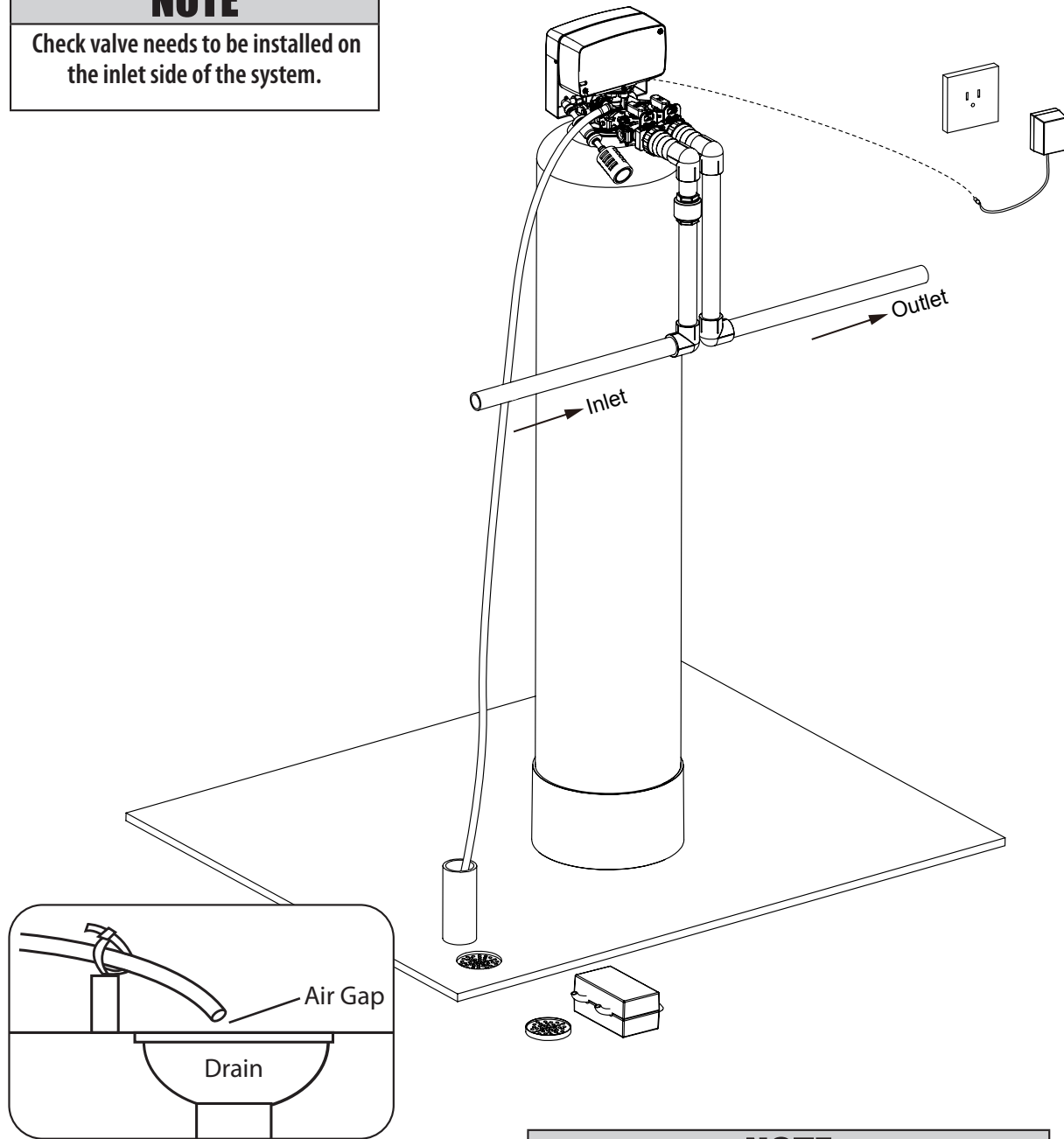

NOTE

Waste connections or drain outlet shall be designed and constructed to provide for connection to the sanitary waste system through an air-gap of 2 pipe diameters or 1 inch (22 mm) whichever is larger.



CAUTION

Never insert drain line directly into a drain, sewer line, or trap. Always allow an air-gap between the drain line and the wastewater to prevent the possibility of sewage being back-siphoned into the filter.

INSTALLATION STEPS

TO BEGIN YOUR INSTALLATION:

1. Make sure the bypass is attached securely to the control valve.
2. Apply thread tape to threaded connections elbow plumbing adaptors
3. Apply the supplied lubricant (#92360) to the O-rings of the fittings.
4. Connect the supplied elbow plumbing adaptors to the bypass with red clips.
5. Connect the inlet and outlet of the water filter to the plumbing of the house.

NOTICE

Any solder joints near the valve must be done before connecting any piping to the valve. Failure to do this could cause damage to the valve.

NOTICE

Do NOT use pipe thread compound as it may attack the material in the valve body.

NOTICE

Failure to leave enough distance could cause damage to the valve. Always leave at least 6" [152 mm] between the valve and joints when soldering pipes that are connected to the valve.

6. For the drain line connection; attach a 1/2" [12.7 mm] Inside Diameter (ID), 5/8" [15.875 mm] Outside Diameter (OD) drain hose to the drain line fitting.
 - a. Run the drain line to a floor or laundry drain.
 - b. Complete any necessary plumbing to maintain a proper air gap.

Make sure both brass and plastic nuts are tightened well

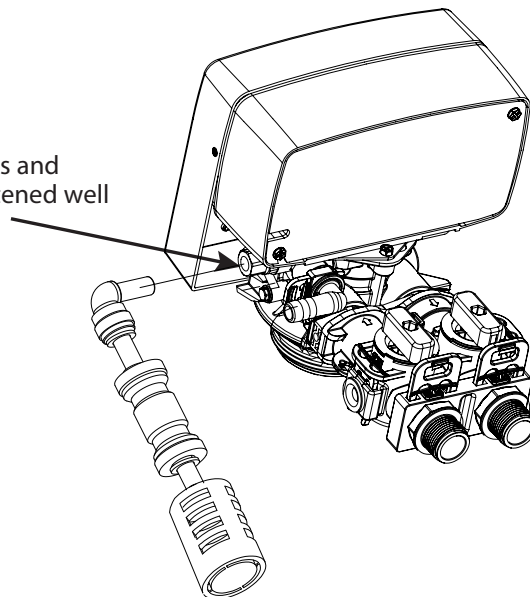

INSTALLATION STEPS (CONTINUED)

7. Using the included Allen key, place the unit in the bypass position.
 - a. Slowly turn the main water supply ON.
 - b. At the nearest cold treated water tap, remove the tap screen, OPEN the tap and let water run a few minutes or until the system is free of any air or foreign material resulting from the plumbing work.

MANUAL WATER BYPASS

In case of an emergency, or to perform filter maintenance, you can isolate your water filter from the water supply using the bypass valve located at the back of the control.

In normal operation the bypass is OPEN with the ON/OFF knobs in line with the INLET and OUTLET pipes, i.e., the black marks in the vertical position. See SERVICE below.

To isolate the filter, simply rotate the knobs as indicated to the CLOSE position until they lock. You can continue to use your water related fixtures as the water supply is bypassing the filter. However, the water you use will be untreated.

To resume treated service, OPEN the bypass valve by rotating the knobs back to the SERVICE position.

NOTE
If the tap has a screen, it should be removed to allow debris to flush out of the plumbing.

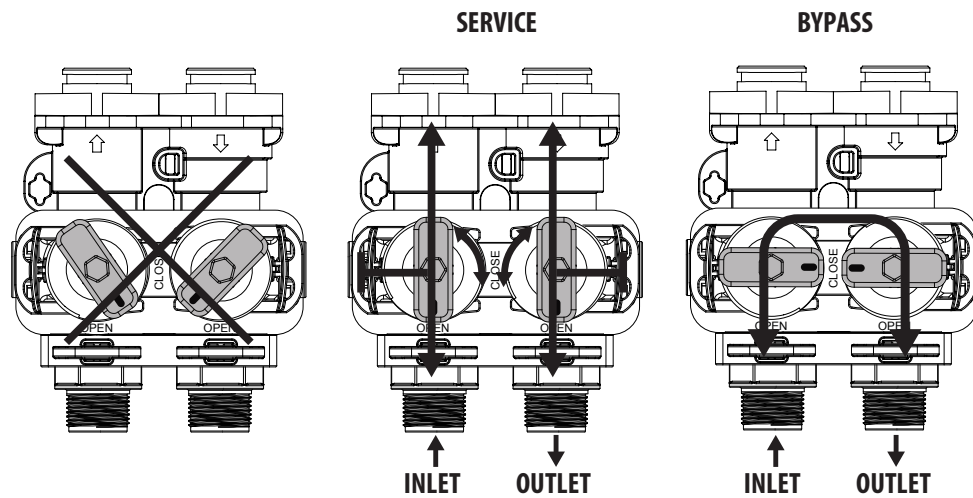

NOTE
Please make sure bypass knobs are completely open otherwise the untreated water may enter through the valve.

UNDERSTAND THE SCREEN & KEYPAD CONFIGURATION

The control valve is controlled with simple, user-friendly electronics, displayed on an LCD screen.

CONNECT THE TRANSFORMER



Connect the transformer to the unit by plugging the 12 volt transformer into a 120 VAC 60 Hz outlet.

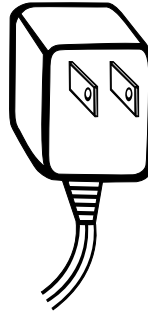
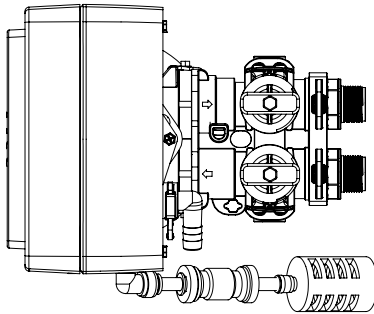

WARNING

If your power supply is subject to surges or frequent outages, surge protection is recommended to protect the electronics in this product

When the power is connected, the screen will show the following information in sequence:

1. Time of Day
2. Remain Days
3. Total Remaining U.S. Gallons.

Key Pad Configuration – the terminology used on the control valve label may vary by model. For the purpose of programming, this manual will use numbers associated with each button position as shown below:

MENU This function is to enter the basic set up information required at the time of installation.

SET/REGEN This function is to initiate an immediate or delayed manual regeneration.

+/- Increase or decrease the value of the settings while in the programming mode.



MANDATORY

Do NOT use an outlet that is controlled by a light switch.

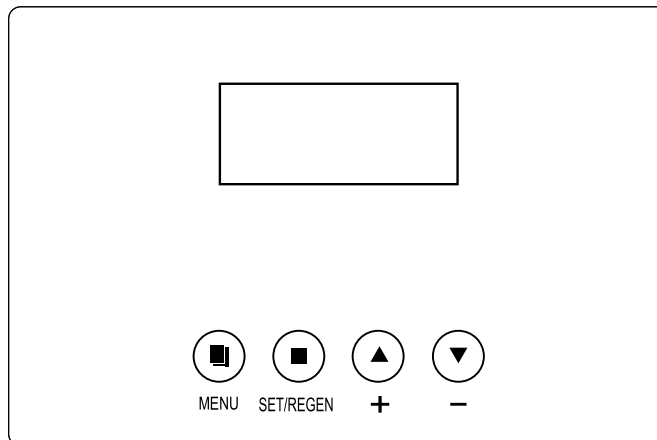

START-UP INSTRUCTIONS

Now that your water conditioner is plumbed into position it is time to start up and program the unit.

STEP 2. PURGE AIR FROM THE UNIT

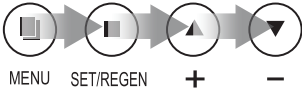

1. Press and hold **SET/REGEN**.
2. Press **SET/REGEN** to make screen flash.
Then press **+** or **-** to change DELAY to IMMEDIATE.



3. Press **SET/REGEN** to accept the change.



4. Press **MENU** to start BACKWASH.

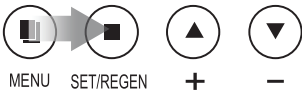
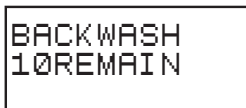

6. Valve will automatically advance to backwash position.

7. **Open the bypass inlet very slowly** until there is a steady stream of water at the drain. Opening the bypass inlet too quickly could result in resin being expelled from the unit and into the plumbing lines. With the valve in the backwash position the unit will purge air from the system, sending it to the drain. This may take longer than the programmed backwash cycle time, so unplug the power so that the valve will remain in the backwash position.

8. With the bypass inlet now fully open, let the system run until all the air is purged and there is a steady stream of clear water at the drain.
9. Reconnect the power, press button two (2) to advance to the air draw position and allow the unit to draw air for the full AIR DRAW cycle. This will add an air bubble in the second tank to aid in the oxidation.
10. Allow the unit to return to the SERVICE position.
11. Slowly open the bypass OUTLET knob until fully open.

NOTE

If severe loss in water pressure is observed when the filter unit is initially placed in service, the filter tank may have been laid on its side during transit. If this occurs, backwash the filter to 'reclassify' the media.



MANDATORY

Be sure to open the bypass inlet very slowly. Do NOT FULLY open the bypass inlet until there is a steady stream of water at the drain as this will result in media being expelled from the unit

START-UP INSTRUCTIONS (CONTINUED)

STEP 3. USER SETTINGS - setting the time of day is the only adjustment required for your new filter.

Your AIO has been preprogrammed to regenerate at a set amount of gallons or every four (4) days.

Contact your plumber or customer service before making any changes to these other fields.

TIME
10:15 AM



TIME
04:20 AM



HARDNESS
001 GPG



3. Press **SET/REGEN** to accept change and advance to next screen.

4. Do not adjust. Press **SET/REGEN** to advance to the next screen.

PEOPLE
001

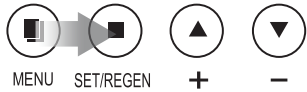

5. Do not adjust. Press **SET/REGEN** to advance to the next screen.

REG. DAYS
04



6. Do not adjust. Press **SET/REGEN** to advance to the next screen.

Congratulations!
Start-Up Instructions are now complete – the unit is operational.

PLUMBING SYSTEM CLEAN UP

The following procedures are guidelines only but have proven successful in most instances. Under no circumstances should any procedure outlined below be followed if contrary to any other household appliances manufacturer's instruction(s). Should there be any questions concerning the advisability of performing a procedure, it is strongly recommended that the dealer be consulted prior to performing the procedure. Canature is not liable for any damages that result of failing to follow the household appliance manufacturer's instructions and/or any issues that arise from following those instructions.

WATER HEATER

If the water heater has been exposed to both iron and hardness for a long period of time, replacement of the heater tank maybe the only practical solution to prevent continued staining originating from this source. After completing the installation of the filter, clean the water heater by following these instructions;

1. Turn the energy supply to the water heater OFF and shut the heater inlet water valve OFF.
2. Drain hot water tank completely. OPEN the Inlet Water Valve allowing the heater tank to be refilled with iron free water. Continue flushing until clear water runs to the drain.
3. If, after 30 minutes flushing, the water does NOT clear, terminate flushing operation.
4. REFILL hot water heater with water and pour approximately .5 gal or [.19 Litres] of household bleach into the top of the heater tank. Allow bleach solution to stand in tank for thirty (30) minutes. Flush tank.
5. Turn the energy supply back ON.

DISHWASHER

Dishwashers may have scale buildup due to prolonged exposure to hard water effecting the factory rated performance. Consult the owner's handbook and follow the manufacturer's instructions.

TOILET FLUSH TANKS

To clean up toilet flush tanks:

1. Pour 4 to 6 fluid ounces [120-175 millilitres] of resin mineral cleaner, Pro-Rust Out or any other suitable cleaner that contains a mild acid, such as CLR, into flush tanks and bowls, and let stand for one (1) hour.
2. When installation is completed, flush toilets several times with conditioned water.
3. If stains or deposits return, check that the lines are connected to treated water.

SYSTEM MAINTENANCE



Maintenance of your new water filter requires very little time or effort but is essential. Regular maintenance will ensure many years of efficient and trouble-free operation. Check with your local dealer about setting up a regular maintenance plan. Failure to follow maintenance instructions and schedule will result in the unit failing to operate properly and void your warranty.

CARE OF YOUR FILTER

To retain the attractive appearance of your new water filter, occasionally clean it with a mild soap solution. Do NOT use abrasive cleaners, ammonia, or solvents.

SERVICE SCHEDULE

- The seals and spacers along with the piston assembly should be inspected/cleaned or replaced annually or as required depending on the inlet water quality and water usage. See Inspection and Replacement of Piston Assembly and Seal and Spacer Kit.
- The injectors should be cleaned/inspected or replaced annually or as required depending on the water quality and use. See Clean Injector Assembly.
- Your inlet water quality and water consumption will determine how often the media should be replenished or replaced. Check with your water treatment expert for the media bed change frequency.
- Maintenance materials – Please see Common Spare Parts.
- Type M units only. The pH of your Raw water and treated water should be monitored at least monthly for the first year to determine when additional media will be required. Once the pH is equal or below 7.0 additional media will be needed to refresh the media bed please order item 95442 5 lb Jar of pH Adder.

SERVICING YOUR CONTROL VALVE

BEFORE SERVICING, YOU WILL NEED TO:

1. Shut the water supply to the filter OFF, put the filter into the BYPASS position.
2. Relieve water pressure in the filter by stepping the control into the backwash momentarily.
3. Return the control to the SERVICE position.
4. Unplug the electrical cord.
5. Disconnect the drain line connection.

Always follow these steps prior to servicing the valve.

POWERHEAD REMOVAL

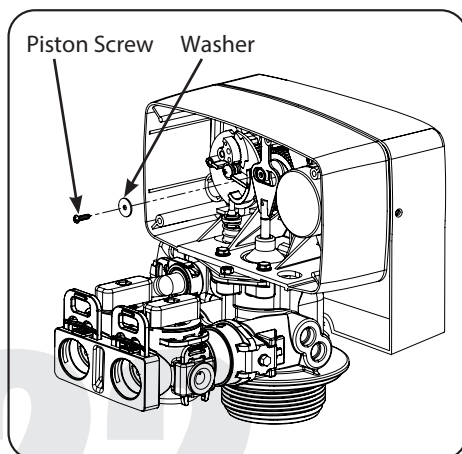

To remove the powerhead:

1. Remove the piston screw and washer from the piston rod.

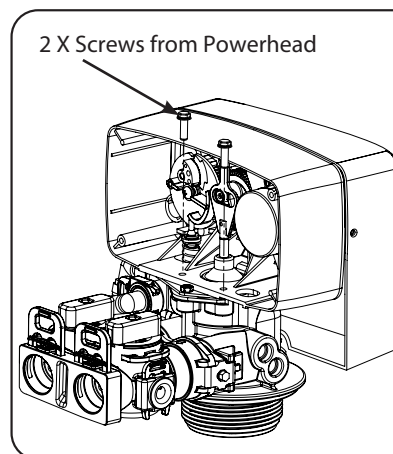

2. Remove the two screws from the powerhead as shown
3. Remove powerhead from body

	CAUTION
RISK OF FLOOD Disassembly while under pressure can result in flooding.	
	WARNING
RISK OF SHOCK Unplug the unit before removing the cover or accessing any internal control parts.	

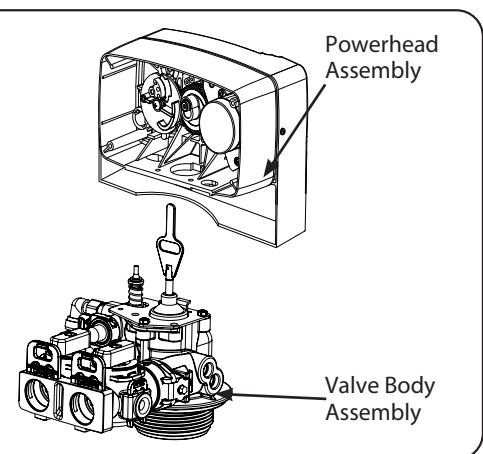

SERVICING YOUR CONTROL VALVE (CONTINUED)

INSPECTION & REPLACEMENT OF PISTON ASSEMBLY AND SEAL & SPACER KIT

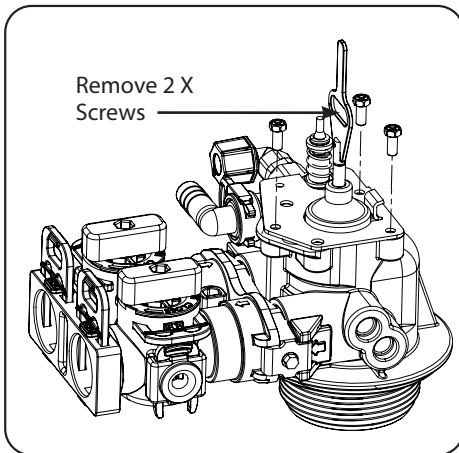

1. Follow steps 1 to 3 of Powerhead Removal above.
2. Remove four (4) screws from the plate on the valve body.

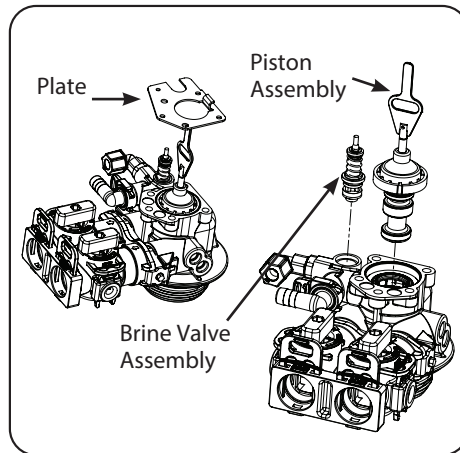

3. Remove the plate from the valve body and pull the piston assembly from the valve. The brine valve assembly can also be removed in this stage.
4. If only lubricating, remove the piston assembly, grease it with silicone lubricant (Part #92360) and put back in.

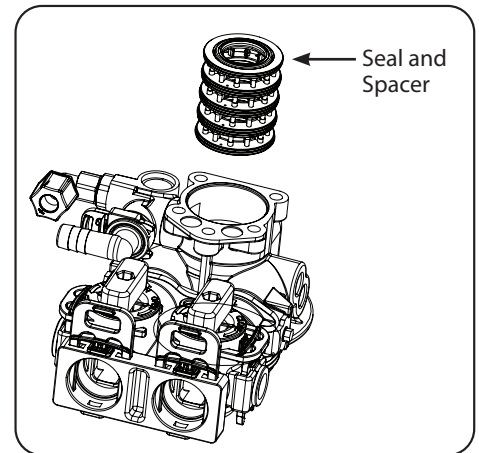

5. Replace seal and spacer set as shown. Place spacer in then a seal and repeat until finishing with a seal. Important, use the specialized end spacer and note it's placement.
6. Lubricate the piston assembly with silicone lubricant (Part #92360) and then replace the Piston Assembly.

NOTICE

Do NOT use petroleum-based grease products during replacement and assembly.

SERVICING YOUR CONTROL VALVE (CONTINUED)

CLEAN INJECTOR ASSEMBLY

Sediment, salt, and silt will restrict or clog the injector. A clean water supply and pure salt will prevent this from happening. The injector assembly is located on the right side of the control valve when facing your softener.

The assembly is easy to clean, start by:

1. Shut the water supply to your softener OFF.
2. Reduce the pressure by opening a cold-treated tap.
3. Using a screwdriver, remove the two (2) screws holding the injector cover to the control valve body.
4. Carefully, remove the cover, and disassemble as shown below.
5. The injector nozzle is removed from the valve body by carefully turning it out with a screwdriver.
6. Remove the injector throat the same way.
7. Carefully flush all parts including the screen.
8. Use a mild acid such as vinegar or Pro Rust Out to clean the small holes in the nozzle and throat.
9. Reassemble by reversing the procedure.

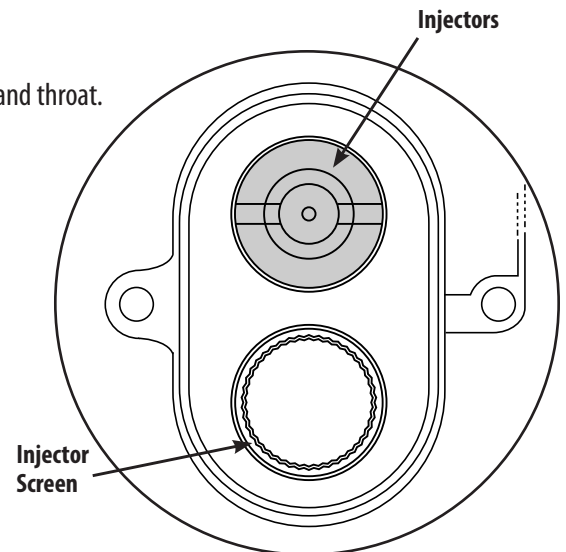
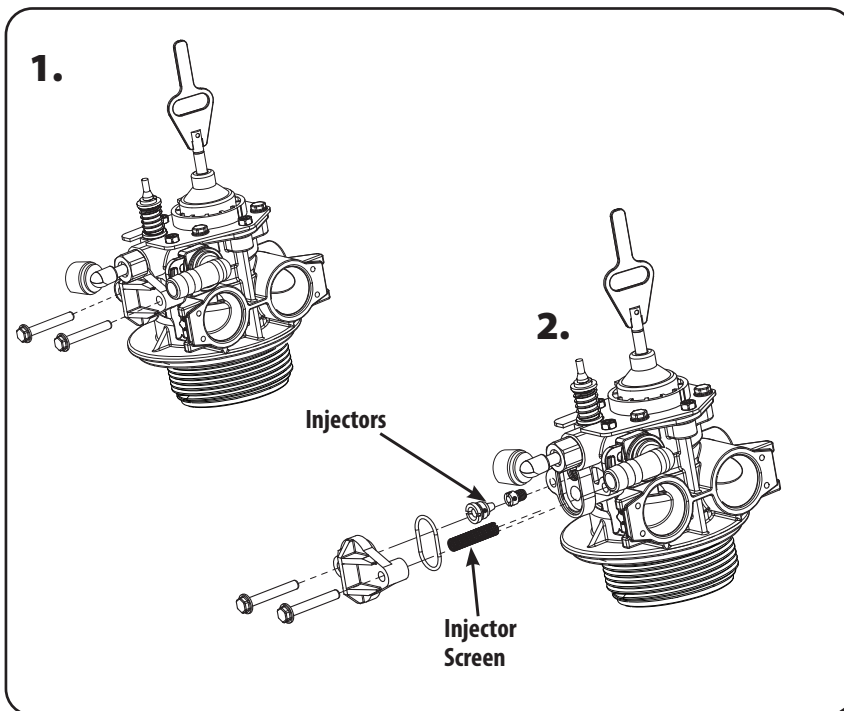

- Remove the two (2) screws of the injector cap.
- Pull the Injector Cap out.
- Remove the Injector Assembly, O-ring, and screen.
- Clean the injectors and replace the cap.
- Be sure to replace the O-rings when reassembling and lubricate with approved 100% silicone-based lubricant. Order Part #92360.
- During final assembly be sure the injector is seated correctly as shown in figure above.

TROUBLESHOOTING GUIDE

NOTE

Before attempting any troubleshooting, be sure to test the water. The tests should include;

1. Raw water
2. Hot treated water
3. Cold treated water.

PROBLEM	POSSIBLE SOLUTION
DELIVERS UNTREATED WATER	
The bypass is closed, sending raw water past the unit.	Return the bypass valve to the open position to service the home. See Manual Bypass.
Bypass loop in the home's plumbing.	Close outlet valve only on filter bypass, open nearest softened water line. If no water flows, then there is not a bypass in the plumbing. If there is water flow, then there is a hidden bypass in the plumbing and you need to call the installer.
Not programmed correctly for the current application.	Verify programming is set correctly for the current application. Verify programming is set to correct the hardness level and the number of people living in the home. See Start-Up & Programming.
Type M units only. The pH of your Raw water and treated water should be monitored at least monthly for the first year to determine when additional media will be required.	Once the pH is equal or below 7.0 additional media will be needed to refresh the media bed. Please order item 95442 5 lb Jar of pH Adder.
NOT REGENERATING AUTOMATICALLY, NOT METERING FLOW	
Check diagnostics for last regeneration.	Open nearest softened water outlet and check if gallons are counting down on meter. If not metering, contact your authorized installer.
NOT REGENERATING AUTOMATICALLY CAUSING ALARMS	
Caused by a power outage or brownout during regeneration.	Unplug power for thirty (30) seconds then reconnect. If the alarm continues contact your authorized installer.
ALARMS AFTER REGENERATION	
Caused by a power outage or brownout during regeneration.	Unplug power for thirty (30) seconds then reconnect. If the alarm continues, contact your authorized installer.
Corroded or damaged rear circuit.	Contact authorized installer and replace circuit.
EXCESSIVE PRESSURE LOSS	
Peak or continuous service flow rate may be exceeding capacity causing the unit to be restrictive due to size.	Check unit specifications to ensure proper sizing for the application. Drain line is blocked causing unit not to regenerate correctly - clean drain line and DLFC control

TROUBLESHOOTING GUIDE (CONTINUED)

PROBLEM	POSSIBLE SOLUTION
WATER CLEAR WHEN DRAWN; TURNS RED UPON STANDING (STAIN PRODUCING)	
Insufficient air in air tank.	<ol style="list-style-type: none"> 1. Increase Brine Time (air draw) 2. Check valve not working.
Bypass open or leaking.	Close bypass and/or repair as necessary.
Filter bed overloaded with precipitated iron due to insufficient backwash.	Increase backwash frequency. Upon correction of problem, manually backwash until backwash water starts to clear. In more severe iron fouling cases, bed may chemical cleaning contact dealer.
Presence of manganese or tannins.	Recheck water analysis.
Flow rate excessive for model.	Check model size and specifications
WATER RED WHEN DRAWN FROM TAP	
Filter bed overloaded with precipitated iron due to insufficient backwash flow rate.	<ol style="list-style-type: none"> 1. Recheck well pumping rate for backwash and repair or replace as required. 2. Check for obstructions or kink in drain line. 3. For improper drain line flow controller, see specs. Upon correction of this problem, if manually backwashing does not clear bed of iron, filter bed may need chemical cleaning contact dealer.
Filter bed overloaded with precipitated iron due to insufficient backwash.	Increase backwash frequency. Upon correction of problem, manually backwash until backwash water starts to clear. In more severe iron fouling cases, bed may need chemical cleaning contact dealer.
Insufficient air in air tank.	<ol style="list-style-type: none"> 1. Increase Brine Time (air draw). 2. Check valve not working.
EXCESSIVE PRESSURE LOSS THROUGH FILTER	
Filter bed overloaded with precipitated iron.	See problem above.
Control inlet/outlet valve(s) not fully open.	Open valves.
Sand, silt or mud collecting in filter bed.	Check well for these conditions.
Filter bed not properly classified.	Manually backwash to reclassify.
MILKY OR BUBBLY WATER (APPEARS TO CONTAIN SMALL BUBBLES)	
Common with this type of filter.	None.
Excess gases in water (carbon dioxide, hydrogen sulphide, methane).	May require draining of water system or installation of air relief control contact dealer.
Excessive flow rate through the unit.	Refer to specifications for the unit. Do not exceed recommended service flow rates. Restrict manually with a valve or contact dealer for a flow restrictor.
UNIT FAILS TO INITIATE A REGENERATION CYCLE	
No power supply.	Check electrical service, fuse, etc.
Defective circuit board.	Replace faulty parts.
Power failure.	Reset time if necessary, initiate manual regeneration to reset.
LOW WATER PRESSURE	
Iron or scale build up in line feeding unit.	Clean pipes.
Iron build up inside valve or tank.	Clean control and add resin cleaner to clean bed. Increase regeneration frequency.
Inlet of control plugged due to foreign material.	Remove piston and clean control valve.
FILTER MEDIA IN DRAIN LINE	
Air in water system.	Check well system for proper air eliminator control.
Incorrect drain line flow control (DLFC) button.	Check for proper flow rate.
VALVE CONTINUOUSLY CYCLES	
Defective position sensor PCB.	Replace faulty parts.
FLOW TO DRAIN CONTINUOUSLY	
Valve settings incorrect.	Check valve settings.
Foreign material in control valve.	Clean control.
Internal leak.	See maintenance page 22.

COMMON SPARE PARTS

Part Number	Description
60090003	QC Valve connector one (1) inch straight with O-ring
60090006	QC Valve connector three-quarters (3/4) inch straight with O-ring
60090010	QC Valve connector three-quarters (3/4) inch elbow with O-ring
60010025	Locking clip large
60010069	Locking clip small
60010006	Bypass tool
60010052	Transformer 12 volt
92360	100% silicone-based lubricant
99003	Media Funnel
60010027	Piston Assembly
60010409	Seals and Spacers kit
60010417	Brine Valve

WARRANTY

Econo Flo AIO Residential Water Filter

NOTICE: THIS MANUAL CONTAINS A LIMITED WARRANTY. BY INSTALLING AND/OR USING THIS PRODUCT, YOU WAIVE CERTAIN LEGAL RIGHTS INCLUDING THE RIGHT TO SUE OR CLAIM COMPENSATION IN THE EVENT OF PROPERTY DAMAGE, INJURY AND/OR DEATH.

Products manufactured and assembled by Canature WaterGroup™ are warranted to do the work for which they are intended where properly installed, operated and maintained. Canature WaterGroup™ warrants each new residential water filter to be free from defects in materials and workmanship subject to the qualifications or exclusions below.

Residential Systems are defined by pressure tank size and / or the amount of resin or filter media contained in the tank. Residential systems use up to 13" [330 mm] diameter tanks and can contain up to 3.0 cubic feet [28.3 L] of resin or filter media.

Warranty on Control Valve and Parts:

Canature WaterGroup™ will replace or repair any part (except for Wear and Tear Items – Media, Piston, Seals and Brine Valve) which fails within five (5) years from date of manufacture, as indicated by the serial number, provided the failure is due to a defect in material or workmanship. The only exception from the date of manufacture shall be proof of purchase or installation is provided and then the warranty period shall be from the date thereof.

Warranty on Mineral Tanks and Brine Tanks:

Canature WaterGroup™ will provide a replacement mineral tank or brine tank to any original equipment purchaser in possession of a tank that fails within ten (10) years, provided the failure is due to a defect in material or workmanship and that the water filter or filter is at all times operated in accordance with specifications provided in the Owner's Manual and not subject to freezing or vacuum.

Exclusions:

Damage to any part of this water filter or filter as a result of misuse, misapplication, neglect, alteration, accident, installation or operation contrary to our printed instructions, damage to ion exchange resin and seals caused by chlorine / chloramines in the water supply, damage to internal pistons and seals caused by wear and tear from iron, manganese, sediment and or silt, or damage caused by any force of nature is not covered in this warranty. At our sole discretion, we will repair or replace defective parts if our warranty department determines it to be defective under the terms of this warranty. Canature WaterGroup™ assumes no responsibility for consequential damage, labor or expense incurred as a result of a defect or failure. Media and Resin coverage is limited to the warranty provided by the original manufacturer.

As a manufacturer, we do not know the characteristics of your water supply. The quality of water supplies may vary seasonably or over a period of time. Your water usage may vary as well. Water characteristics can also change if the appliance is moved to a new location. For these reasons, we assume no liability for the determination of the proper equipment necessary to meet your requirements, and we do not authorize others to assume such obligation for us. Further, we assume no liability and extend no warranties, express or implied, for the use of this product with a non-potable water source or a water source which does not meet the conditions for use as described in the Owners Guide.

CANATURE WATERGROUP'S™ OBLIGATIONS UNDER THIS WARRANTY ARE LIMITED TO THE REPAIR OR REPLACEMENT OF THE FAILED PARTS OF THE WATER SOFTENING SYSTEM AND WE ASSUME NO LIABILITY WHATSOEVER FOR DIRECT, INDIRECT, INCIDENTAL, CONSEQUENTIAL, SPECIAL, GENERAL OR OTHER DAMAGES.

Return of Goods:

An authorization number must be obtained before returning any merchandise. NOTE: All material returned to Canature Watergroup must be returned freight prepaid. Upon inspection, if our warranty department determines the goods to be defective under the terms of this warranty, the warranty shall be limited to the defective parts to be repaired, replaced, or credited at Canature WaterGroup's discretion. You pay only freight to return defective parts to our factory and local dealer charges, including but not limited to labor charges, travel and transportation expenses, and handling fees.

Some State & Provincial jurisdictions do not allow limitations on how long an implied warranty lasts, so the above limitation may not apply to you. Similarly, some State & Provincial jurisdictions do not allow exclusion of incidental or consequential damages, so the above limitations or exclusions may not apply to you. This warranty gives you specific legal rights, and you may also have other rights, which vary from jurisdiction to jurisdiction. Consult your authorized Dealer for warranty and service information.