

Model 2900
2" Top Mount Valve
Softener Unit

Cambridge, Ontario, Canada

-

Fridley, Minnesota, USA

-

Regina, Saskatchewan, Canada

-

Sun Valley, California, USA

Read manual thoroughly before proceeding with installation

Nov 06
#45982

\$50.00

Customer _____
 Project No. _____
 Unit Serial No. _____
 Valve Serial No. _____
 Assembly Date _____
 Assembled By: _____

Model _____ - _____

Softener Type

FAF - Fiberglass
 Tank Automatic
 Control Valve
 AS - Steel Tank
 Automatic
 Control Valve

Softener Capacity (grains)

1ft³ resin =
 30,000 grain
 capacity.

Valve Size

1 - 2750 Valve-1"
 1.5 - 2850 Valve-1.5"
 2 - 2900 Valve-2"
 2A - 3130 Valve-2"
 2B - 2930 Valve-2"
 2.0 - 3150 Valve-2"
 3 - 3900 Valve-3"

Number of Units

S - Single
 D - Duplex
 T - Triplex

Options

O - Standard
 1-Systemax
 2-ET
 4-Systemax System 14
 7-Alternating Systemax
 X - Non standard
*Refer to Option List for
 Non Standard Options*

Option List

- Treated Water Regeneration Kit
- Auxilliary Contacts
 Description _____
- System Max 2000 Programmable Controller
- ET Digital Controller
- Environmental Enclosure
- Side Mounted Valve:
 (2850, 2900, 3150 & 3900 Valves Only)
- 220 VAC/50Hz Power Supply
 (115 VAC/60Hz standard)
 Other, (specify). _____
- Other, (Specify). _____

System Type

C- Calendar Clock
 4 - Single Meter Initiated
 5 - Multi Unit Meter
 Initiated
 Parallel Operation
 6- Single Meter Initiated
 Parallel Operation
 7 - Multi Unit Meter
 Initiated
 Alternating Operation

Table Of Contents

Section 1 Product Summary

1.1 Product Summary

Section 2 General Specifications

2.1 Operating Parameters

2.2 Tanks

2.3 Standard Distribution

2.4 Control Valve

2.5 Performance

2.6 Regeneration Cycle Times, Injectors, Refill Controls

Section 3 Inspection

3.1 General Inspection

Section 4 Installation

4.1 Tank Positioning

4.2 Media Installation

4.3 Piping

.1 Treated Water Regeneration

4.4 Electrical

.1 Standard Mechanical And ET

.2 Systemax

4.5 Valve Wiring Diagrams

Section 5 Media Specifications

5.1 Media Description

5.2 Media Bed Quantities

Section 6 Softener Parts Breakdown

6.0 Major Components

6.1 Control Drive Assembly

6.2 Valve Timer Assembly

6.3 Valve Body Assembly

6.4 Brine Valve Assembly

6.5 Service Valve Operator (SVO)

6.6 Meter Assembly

6.7 Remote Meter Timers

Section 7 Start Up

7.1 Unit Start Up

Section 8 Operation

8.1 Operating Conditions

8.2 Cycle Operation

.1 Service

.2 Backwash

.3 Brine Draw Position

.4 Rinse

.5 Brine Tank Refill

Section 9 Control

9.1 Calendar Clock

9.2 Meter

9.3 Regeneration Cycle Timer

9.4 Regeneration Program

9.5 Changing the Regeneration Cycle Times

Section 10 Troubleshooting

10.1 Troubleshooting

Section 11 Seals & Spacers

11.1 Seal & Spacer and Piston Replacement

Appendix A

Structural Manual – Pressure Vessel Lifting, Handling & Installation Instructions

Section 12 Warranty

Section 1.1 Product Summary

You have just acquired a WaterGroup Companies Inc. / WaterGroup Inc. commercial softening system. Your system may be equipped with one of the following control systems.

Calendar Clock – The calendar clock softener can be a single or multiple unit softener. The single unit comes with standard with delayed regeneration (typically 2:00 am) and has a hard water bypass piston. The duplex or more units also comes standard with delayed regeneration and has a no hard water bypass pistons. These units are not electrically interlocked so the regeneration time must be staggered so more than one unit does not regenerate at a time.

System 4 – The system 4 is a single meter initiated unit. It comes standard with delayed regeneration (typically 2:00 am) and has a hard water bypass piston.

System 5 – The system 5 is a duplex meter initiated system with all units in parallel service. Each unit has its own meter and brine tank. Regeneration is immediately at end of service run and an electrical interlock prevents regeneration of a unit while another is in regeneration. No hard water bypass pistons are standard.

System 6 – The system 6 is a duplex meter initiated system with all units in parallel service. Each unit has its own brine tank but shares a common meter on the outlet header. Regeneration is immediately at end of service run and is series regeneration. No hard water bypass pistons are standard.

System 7 – The system 7 is a duplex alternating (service/stand-by) system with one unit on line and the other in regeneration or stand-by. The system comes standard with one brine tank and one meter on the common outlet header. Hard water bypass is prevented with no hard water bypass pistons (2900 or 3900 valve) and automatic diaphragm valves on all other types.

Options

ET Controller – A precise electronic available with all of our commercial control valves. A bright 7 digit display shows flow and totalizer information and programming is easy with the simple touchpad design. The enclosure is hinged to allow complete access to all internal parts and has a NEMA 3R rating.

Systemax 2000 – New electronic controller monitors and controls up to three water softeners. Featuring a bright 8 digit display, the Systemax can be programmed for each softener individually or as a system, allowing the operator to view flow rates, flow totals and operating status of any softener unit. Electrical connections are simple, prewired interlock cables supplied with the controller. Enclosure rating is NEMA 4X.

Systemax Options:

- ❖ **Systemax 2014** electronic demand recall controller. The Systemax monitors the total system flowrate, and automatically places the required number of units on line to meet the current flow conditions.
- ❖ **Remote Monitoring** – Allows the operator to remotely monitor the Systemax on a PC. This provides access to all front panel data and programming information (such as system status and flowrates) on easy to read screens.

Section 2. 2900 Valve Softeners - General Specifications

2.1 Operating Parameter

Recommended System Operating Range..... 30 - 100 psig, (20.6 kPa - 68.7 kPa)

2.2 Tanks

Size..... 14" x 65", 16" x 65", 21" x 54", 21" x 69" & 24" x 72"

Material, (Standard)..... Fiberglass Reinforced Polyethylene

Maximum Working Pressure..... 150 psi, (1.03 MPa) at 120°F, (49°C)

- All tanks are NSF, (National Sanitation Foundation), approved.

- All standard tanks come with a 4" threaded top hole.

2.3 Distribution

Material, (Standard)..... PVC & Polypropylene

Configuration..... Top Hole Connection, Bottom Hub & Laterals

2.4 Control Valve

Model.....2900

Size..... 2"

Type..... Raw Water Bypass Piston (Single Units)

..... No Raw Water Bypass Piston (Duplex Units)

Material..... Cast Brass

Connection..... Threaded

Working Pressure Range..... 30 - 120 psig, (207 kPa - 827 kPa)

Backwash Flow Control..... Orifice Flow Control

Brine Tank Refill Flow Control..... Orifice Flow Control

Inlet Connection..... 2" FNPT

Outlet Connection..... 2" FNPT

Drain Connection..... 1" FNPT

Recommended Minimum Drain Discharge Piping Size..... 1"

- The valve is electrically operated by either 115 VAC/60Hz (Standard), 220 VAC/50 Hz, or 220VAC/60Hz

2.5 Performance Specifications

Model Number	Resin Capacity (15lb/ft ³)	Resin Capacity (10lb/ft ³)	Resin Capacity (8lb/ft ³)	Service Flowrate (continuous)	Service Flowrate (15 psi loss)	Service Flowrate (25 psi loss)	Tank Size	Unit Weight
FAF 90	90,000	81,000	75,000	26 USgpm	41 USgpm	60 USgpm	14" x 65"	330 lbs
FAF 120	120,000	108,000	100,000	34 USgpm	49 USgpm	70 USgpm	16" x 65"	390 lbs
FAF 150	150,000	135,000	125,000	57 USgpm	76 USgpm	103 USgpm	21" X 54"	500 lbs
FAF 180	180,000	162,000	150,000	57 USgpm	72 USgpm	98 USgpm	21" x 54"	560 lbs
FAF 210	210,000	189,000	175,000	57 USgpm	67 USgpm	93 USgpm	21" x 69"	640 lbs
FAF 240	240,000	216,000	200,000	57 USgpm	63 USgpm	89 USgpm	21" x 69"	690 lbs
FAF 270	270,000	243,000	225,000	45 USgpm	75 USgpm	104 USgpm	24" x 72"	820 lbs
FAF 300	300,000	270,000	250,000	55 USgpm	73 USgpm	102 USgpm	24" x 72"	870 lbs
FAF 330	330,000	297,000	275,000	60 USgpm	71 USgpm	99 USgpm	24" x 72"	920 lbs
FAF 360	360,000	324,000	300,000	60 USgpm	84 USgpm	116 USgpm	30" x 72"	1150 lbs
FAF 390	390,000	351,000	325,000	65 USgpm	82 USgpm	114 USgpm	30" x 72"	1200 lbs
FAF 450	450,000	405,000	375,000	75 USgpm	80 USgpm	112 USgpm	30" x 72"	1360 lbs
FAF 510	510,000	459,000	425,000	79 USgpm	79 USgpm	109 USgpm	30" x 72"	1460 lbs

* - 60PSI is required for proper regeneration

2.6 Regeneration Cycle Times, Injectors, Refill Controls

Model Number	Mineral Tank Size	Canadian Brine Tank Size	Regeneration Cycle Times Backwash--Brine Draw--Fast Rinse--Refill (minutes)	DLFC, BLFC, Injectors
FAF 90	14" x 65"	21" x 36"	10--56--10--22	5, 0.5, #3 Yellow
FAF 120	16" x 65"	21" x 36"	10--68--10--28	7, 0.5, #3 Yellow
FAF 150	21" x 54"	24" x 48"	10--60--10--10	12, 2, 3C Yellow
FAF 180	21" x 54"	24" x 48"	10--72--10--10	12, 2, 3C Yellow
FAF 210	21" x 69"	24" x 48"	10--84--10--12	12, 2, 3C Yellow
FAF 240	21" x 69"	24" x 48"	10--84--10--14	12, 2, 3C Yellow
FAF 270	24" x 72"	30" x 48"	10--62--10--14	15, 2, 4C Green
FAF 300	24" x 72"	30" x 48"	10--70--10--16	15, 2, 4C Green
FAF 330	24" x 72"	30" x 48"	10--78--10--18	15, 2, 4C Green
FAF 360	30" x 72"	30" x 48"	10--66--10--20	25,2,5C Red
FAF 390	30" x 72"	30" x 48"	10--66--10--12	25,4,5C Red
FAF 450	30" x 72"	36" x 48"	10--66--10--12	25,4,6C White
FAF 510	30" x 72"	36" x 48"	10--74--10--14	25,4,6C White

Section 3. Inspection

3.1 General

- Check the product summary to determine what options you have received.
- If you have not received the items that are required for assembly of the softener, please contact your supplier.
- Inspect the equipment, (including internal distribution), for any visible shipping damage. If damaged, notify the transportation company and request a damage inspection. Damage to cartons should also be noted.
- **Read manual thoroughly before proceeding with installation.**
- Handle softener unit with care. Damage can result if dropped or set on sharp, uneven projections on the floor.
- Each softener you have received consists of the following items:
 - Control valve(s).
 - includes assembled valve, backwash and brine line flow controls
 - Fiberglass tank, complete with internal distribution
 - Softener media and gravel support bed
 - Brine tank & accessories, (ie brine tank, tubing, etc.) Note: all standard systems except system 7 have one brine tank per softener.
- Other items that may accompany your softener are:
 - Volumetric meter, (meter initiated units only)
 - Systemax 2000 Programmable Controller.
 - comes with interconnecting cables, and operation manual.
 - Treated water regeneration kit.

Section 4. Installation

4.1 Tank Positioning

- Position the tanks as shown on the installation drawing. See figure 4.1C *Note: The tanks should be located on a level support pad, with adequate access space on all sides, (all units in duplex and/or triplex systems must be within 3 feet of one another for the interconnect cable to properly attach).*
- Check hub and laterals in the tank for any damage that may have occurred during transport. This is critical because if the distribution is broken, the media will be flushed into the service lines.
- Thread the control valve snugly into the tank using silicone grease (# 13691 not included) on o-rings, and adjust softener position until the desired orientation is achieved. *Note: Do not move tank after this is completed, because once the softener media is installed, the unit will be very difficult to move, and damage may occur if the tank is moved when filled with media.*

4.2 Media Installation

- Remove the valve from the mineral tank.
- Temporarily plug the open end of the riser tube to ensure that no resin or gravel falls down into the distribution.
- Fill mineral tank one quarter full of water to protect distribution during gravel installation.
- Slowly and carefully add the gravel support bed and the softener media as outlined in Section 5, Media Specifications, leveling each layer as it is placed into the tank.
- Unplug the riser tube, carefully position the valve over it and turn valve into threads in fiberglass tank, tightening securely into tank. *Note: Ensure that the internal O-ring in the valve fits securely over the riser tube. Silicone grease (#13691) or other food grade lubricant, may be applied to the O-ring to ease installation of the riser tube. DO NOT use petroleum based lubricants as they will cause swelling of O-rings and seals.*
- The softener is now charged with softening resin.
- It is recommended that the softener tank now be completely filled with water (SLOWLY) to soak the resin for approximately 6 hours before startup. This will allow the media to absorb water as well as help displace any trapped air. and this will reduce the chance of backwashing resin out during startup.

4.3 Piping

- Install the piping conforming to federal, provincial and local codes. Unions and/or flanges are recommended and isolation and by-pass valves should also be installed. Flex connections should be used on the inlet and outlet piping to allow for slight expansion and contraction of the fibreglass tank during operation under system pressure. An alternative to flex connectors is the inherent flexibility of right angle system design shown on page 23 of the “Pressure Vessel Lifting, Handling & Installations” manual in appendix A. **For proper system operation and startup, and to monitor the softener’s removal capacity and efficiency, sample points and pressure gauges must be installed on each unit immediately before (on the inlet piping) and after (on the outlet piping) each softener. See Fig. 4.1 for a typical installation.** Putting fibreglass tanks into a vacuum condition will void the tank warranty. If a vacuum condition could ever occur, the tank must be protected by use of a vacuum breaker to ensure the tank does not experience a vacuum condition, see page 23 of the “Pressure Vessel Lifting, Handling & Installations” manual in appendix A.
- The drain line should be as short as possible and must be piped to an open drain. Access to the drain and an air gap are necessary for visual inspection and testing of drain water. The floor drain must be sized to carry the maximum listed flow to drain. (See section 2 for flowrates) It is recommended that the drain pipe size should be at least the same size of pipe or larger as the inlet and outlet piping. (See section 2.4)
- Install the backwash flow control in the drain line piping. The arrow stamped on the side of the control indicates the direction of flow (to drain). The backwash flow rate is controlled by a flow control that is factory set, and does not require adjustment on site. It is recommended that this flowrate be checked by timing and measuring the flow through to the drain.
- If the treated water exiting the system is flowing into an open reservoir, it is recommended that a loop in the piping be installed in the system outlet to prevent the units from draining down, which can lead to operational problems. The loop must extend above the top of the mineral tanks with a vacuum breaker at the high point of the loop, and then drops into the reservoir. Include an air gap to help prevent siphoning. The system will have the best service performance if there is some backpressure on the system (eg. 30 psi). This could be achieved by partially closing a system outlet valve or putting on flow controllers into the outlet piping (not included).
- Any piping before and after the unit(s) must be properly supported, to prevent any stress on the unit by the piping.
- Due to the thermal expansion caused by systems which have a water heater on line with a backflow preventer, installation of a pressure reducing valve is recommended.

Fig. 4.1 Typical Piping Shown Below.

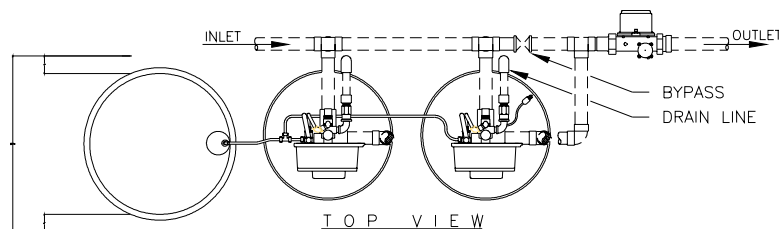

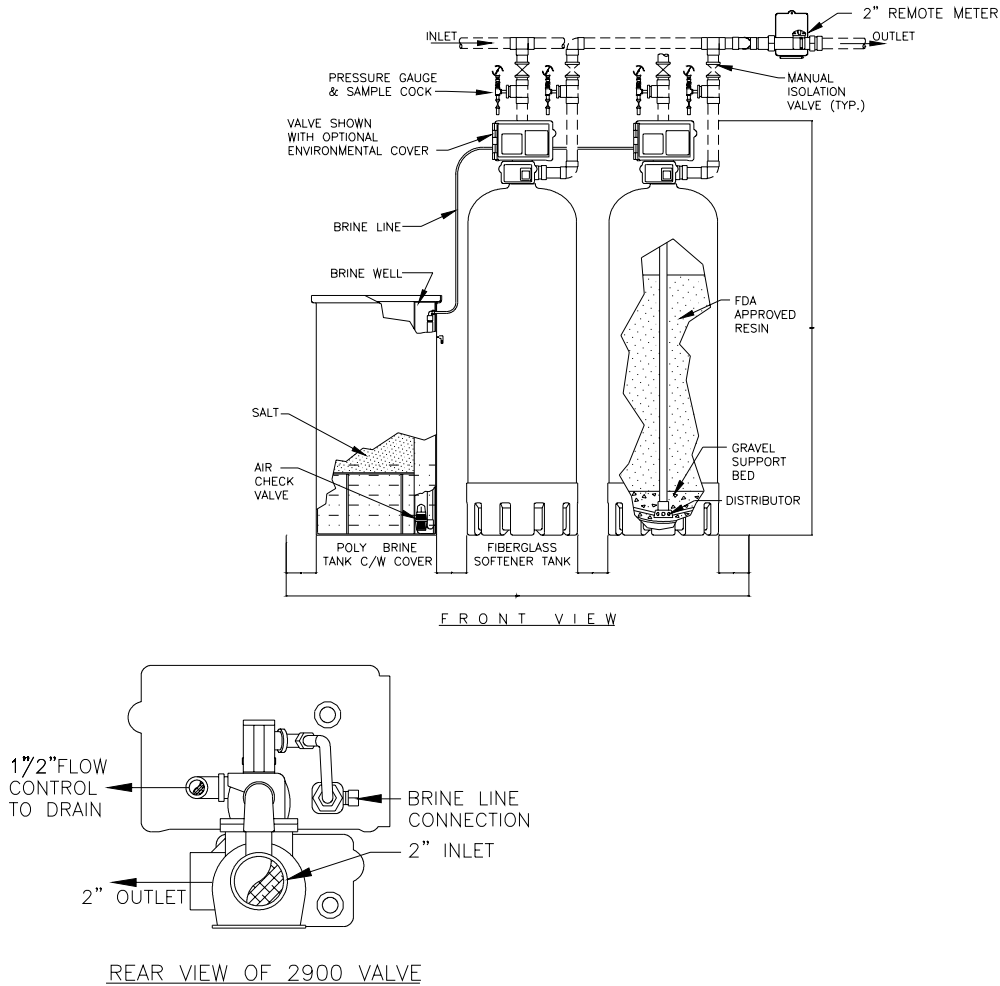

Fig. 4.2 Connections On Softener Valves

Minimum Installation Space*						
Tank Size	Height In(mm)	Width (using largest standard brine tank) In(mm)			Depth In(mm)	
		Single	Duplex 2 Brine Tanks	Duplex 1 Brine Tank	Top Mount	Side Mount
					26(660)	54(1372)
10" Tank	79 (2007)	49(1245)	94(2388)	67(1702)	26(660)	
14" Tank	90(2286)	53(1346)	102(2591)	75(1905)	26(660)	54(1372)
16" Tank	90(2286)	55(1397)	106(2692)	79(2007)	28(711)	56(1422)
21" Tank	90(2286)	63(1600)	122(3099)	92(2337)	33(838)	61(1550)
24" Tank	93(2362)	72(1828)	140(3556)	104(2642)	36(914)	64(1626)
30" Tank	99(2515)	84(2134)	164(4166)	122(3099)	42(1067)	70(1778)
36" Tank	115(2921)	96(2438)	188(4775)	140(3556)	48(1219)	76(1930)
42" Tank	113(2870)	102(2591)	200(5080)	152(3861)	48(1219)	82(2083)
48" Tank	118(2997)	114(2896)	224(5990)	170(4318)	65(1651)	88(2235)

*Note: Required installation space is for the top mounted valve and includes the brine tanks at the sides (installation size shown for the largest valve/tank combination). It is recommended that the brine line to the unit is no longer than 5 feet in length. The brine line is included for units up to the FAF 510. On units larger than, it is recommended that 3/4" or 1" pvc pipe be used (not included).

4.3.1 Optional Treated Water Regeneration Installation

The treated water regeneration kit allows a clean water source to be used as the regeneration water supply. This results in a more efficient regeneration.

The treated water regeneration kit consists of two, pneumatically or hydraulically actuated diaphragm valves (per unit) installed in the piping, as shown on Figure 4.3.

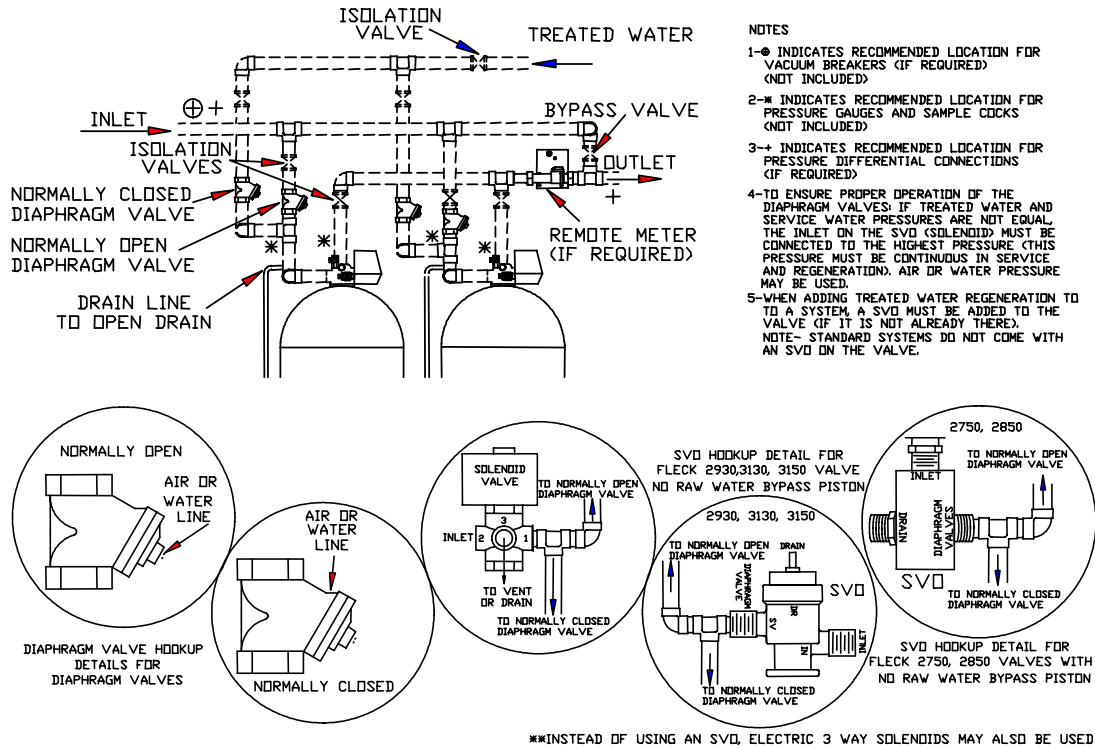

Fig. 4.3 Treated Water Regeneration Kit Typical Installation – Drawing C-1590

- A service valve operator (SVO) or solenoid typically controls the two diaphragm valves. There are two different SVO's; one used for the 2750, 2850, & 2900 valves, and another used for the 2930, 3130, 3150 and 3900 valves. Both are shown here. (2930 & 3130 SVO available in Canada only.)

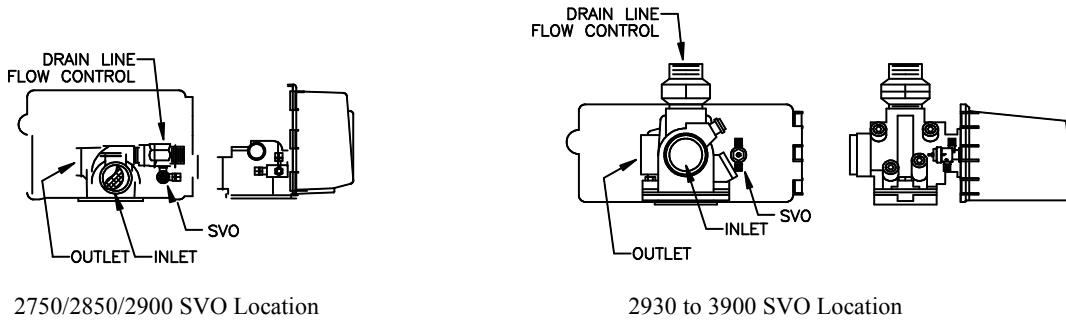

Fig. 4.4 Service Valve Operator Location

- An SVO, or service valve operator has three ports, drain, pressure, and control valve. The diagram below illustrates the location of each of these ports on the SVO. To ensure proper operation of the diaphragm valves, the supply pressure must be a continuous water pressure source and the pressure must be equal to the highest pressure the system will see. If this is not possible, air pressure may also be used with the air pressure set to the highest water pressure the system will see.

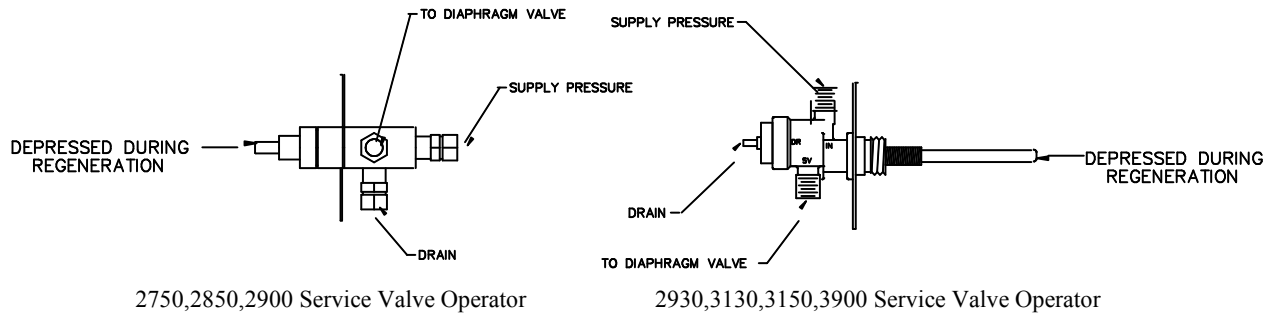

Fig. 4.5 SVO (for Solenoid see Figure 4.10)

4.4 Electrical

4.4.1 3200 and 3200 ET Controlled Units

Electrically connect each unit together with the interconnect cable supplied on the units. The lead unit is denoted by having the power cord. Lag unit only has interconnect cord. Middle unit has receptacle and interconnect cord. External wiring to be done according to federal and provincial regulations, with the power coming from a fused source.

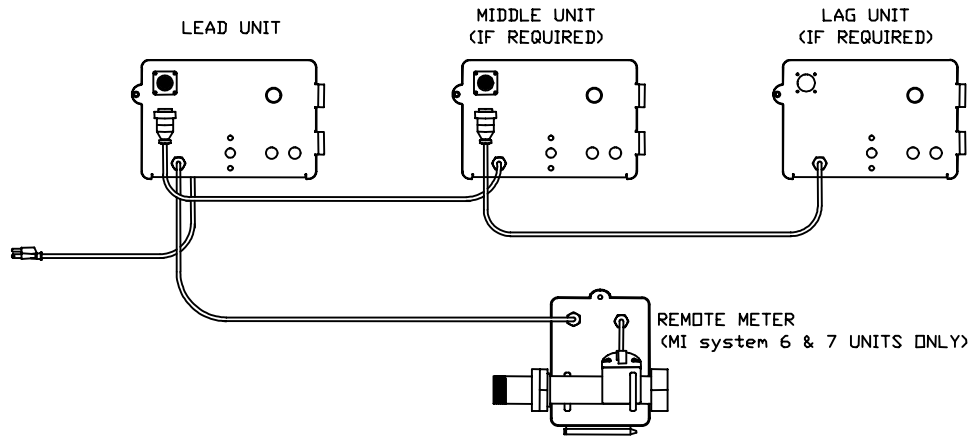

Fig. 4.7 Mechanically and ET Controlled Multiple 2750, 2850, 2900 Unit Electrical Connection

Electrical Connections For 2900/3900

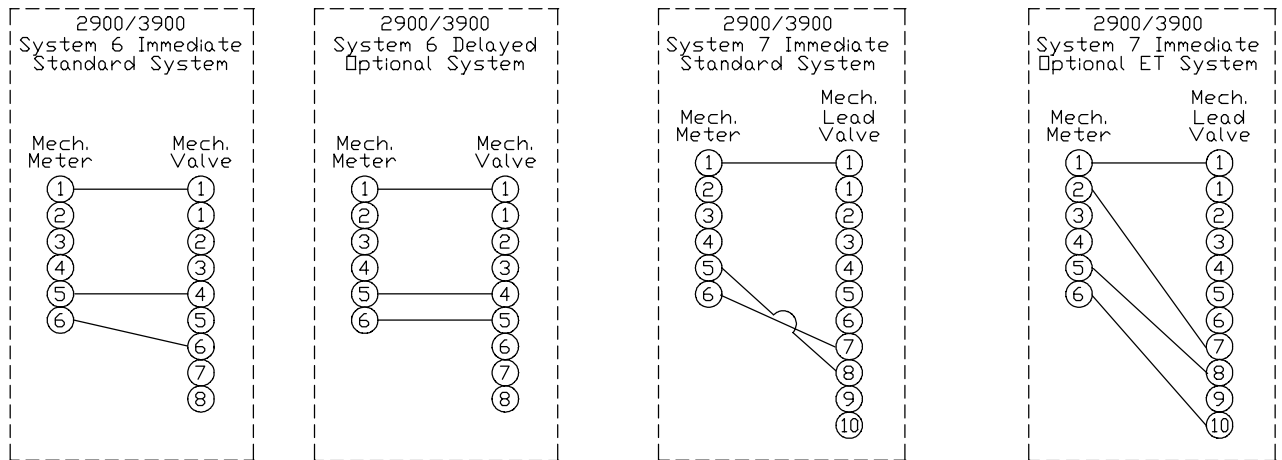

Fig. 4.8 Meter/Timer Connections for 2900/3900 Valves

Note: U.S. companies should look at the Fleck manual for wiring diagrams

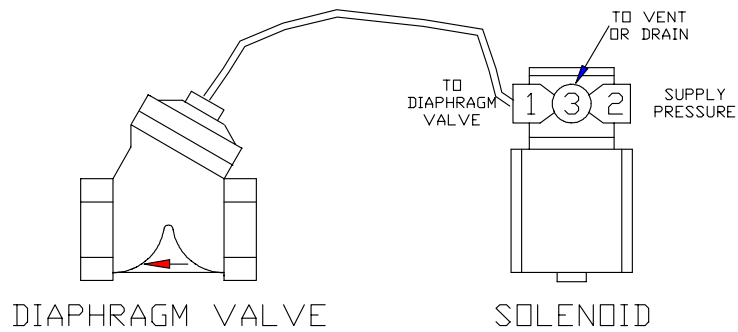
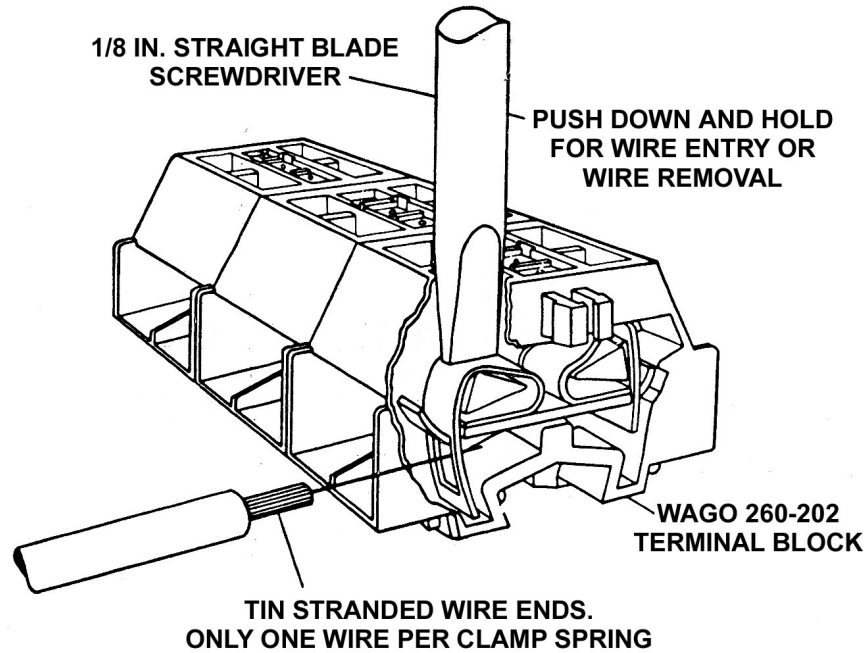

Fig. 4.10 Diaphragm/Solenoid Connections (Also for system 7 & 14 on 2750/2850/3130/3150 Valves)

Note: Supply pressure can be air or water; Solenoid wires are one green (ground) and two red (AC connections)

Note: For Systemax, other ET systems, and custom applications, please refer to complete electrical drawing for wiring details (located in their own separate manual or for custom applications, see addition drawing)

4.4.2 Systemax 2000 Controlled Units

Electrically connect each unit to the Systemax Controller via the interconnect cable supplied on the control panel. All units operated by a System Max Controller are identical, and do not require any particular order. External wiring to be done according to federal and provincial regulations, with the power coming from a fused source. The meter, (if required), are electrically connected to the units terminal strip.

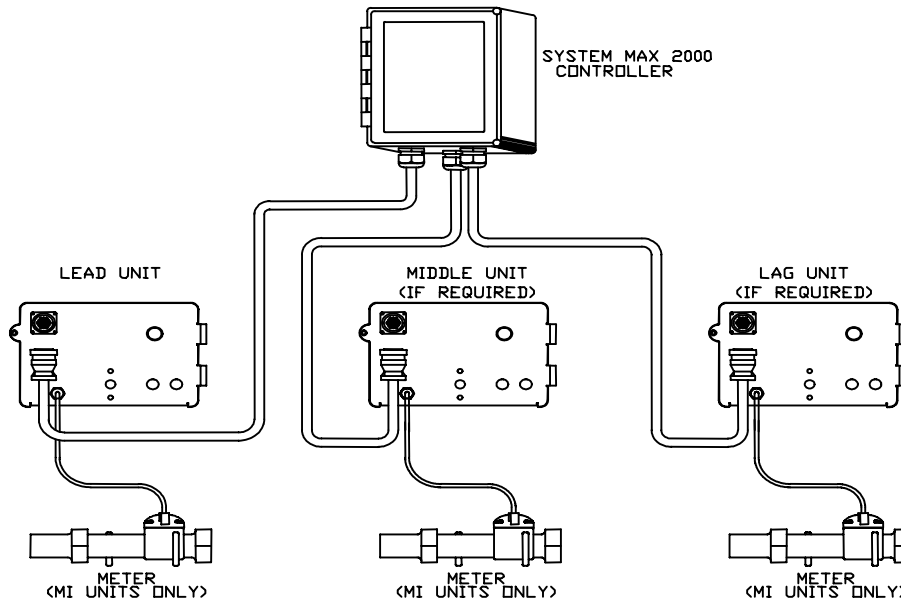

Fig. 4.11 System Max 2000 Controlled Multiple 2750,2850 & 2900 Unit Electrical Connections

Connection of remote meter to Systemax controller (meter initiated units only)

Connect the following terminals:

- Red meter wire to terminal #1, on terminal block #2
- Black meter wire to terminal #2, on terminal block #2
- White meter wire to terminal #8, on terminal block #3

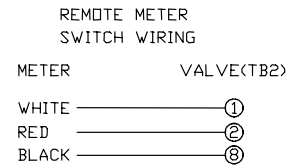

Fig. 4.12 Meter/Systemax Connection

Note: U.S. companies should look at the Fleck manual for wiring diagrams

4.5 Valve Wiring (Standard Mechanical Units Only, Dual Piston Valves)

4.5.1 System 4

System 4 is a single meter initiated unit and the standard is delayed regeneration.

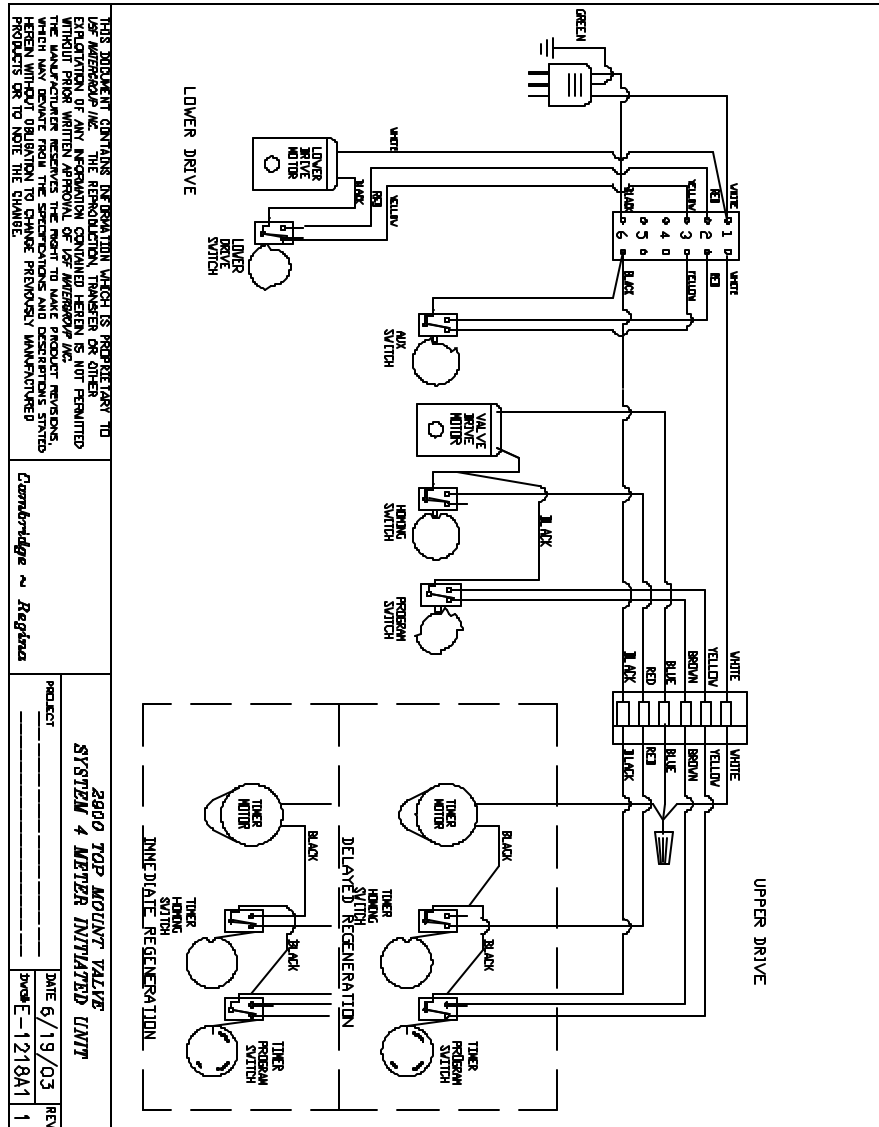

Note: U.S. companies should look at the Fleck manual for wiring diagrams

4.5.2 System 5

System 5 is a duplex softener system, both on line each with it's own meter. Regeneration is immediate and the system is interlocked to allow only one unit to regenerate at a time.

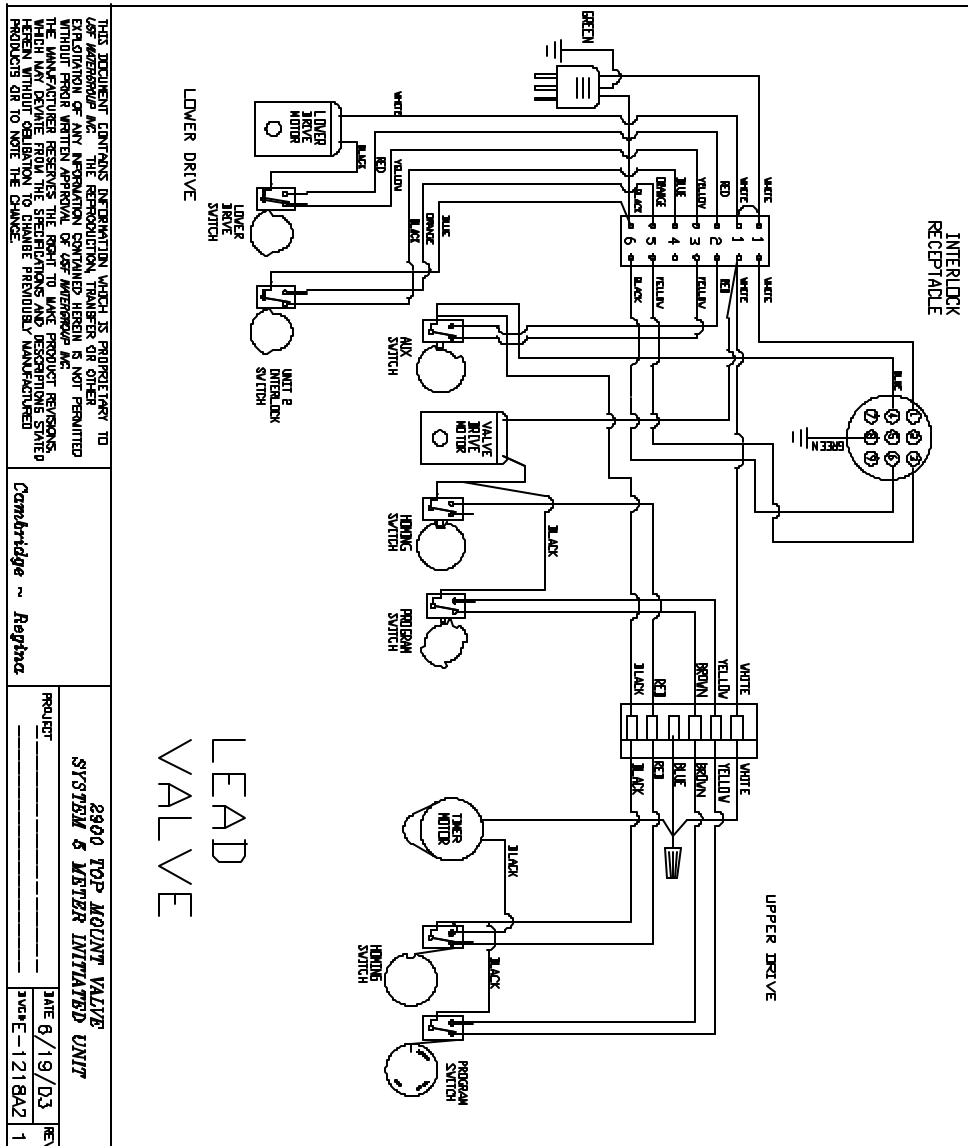

Note: U.S. companies should look at the Fleck manual for wiring diagrams

4.5.3 System 6

System 6 is a duplex softener system, both on line, with one common meter on the system. Regeneration is immediate, series regeneration with one unit regenerating at a time.

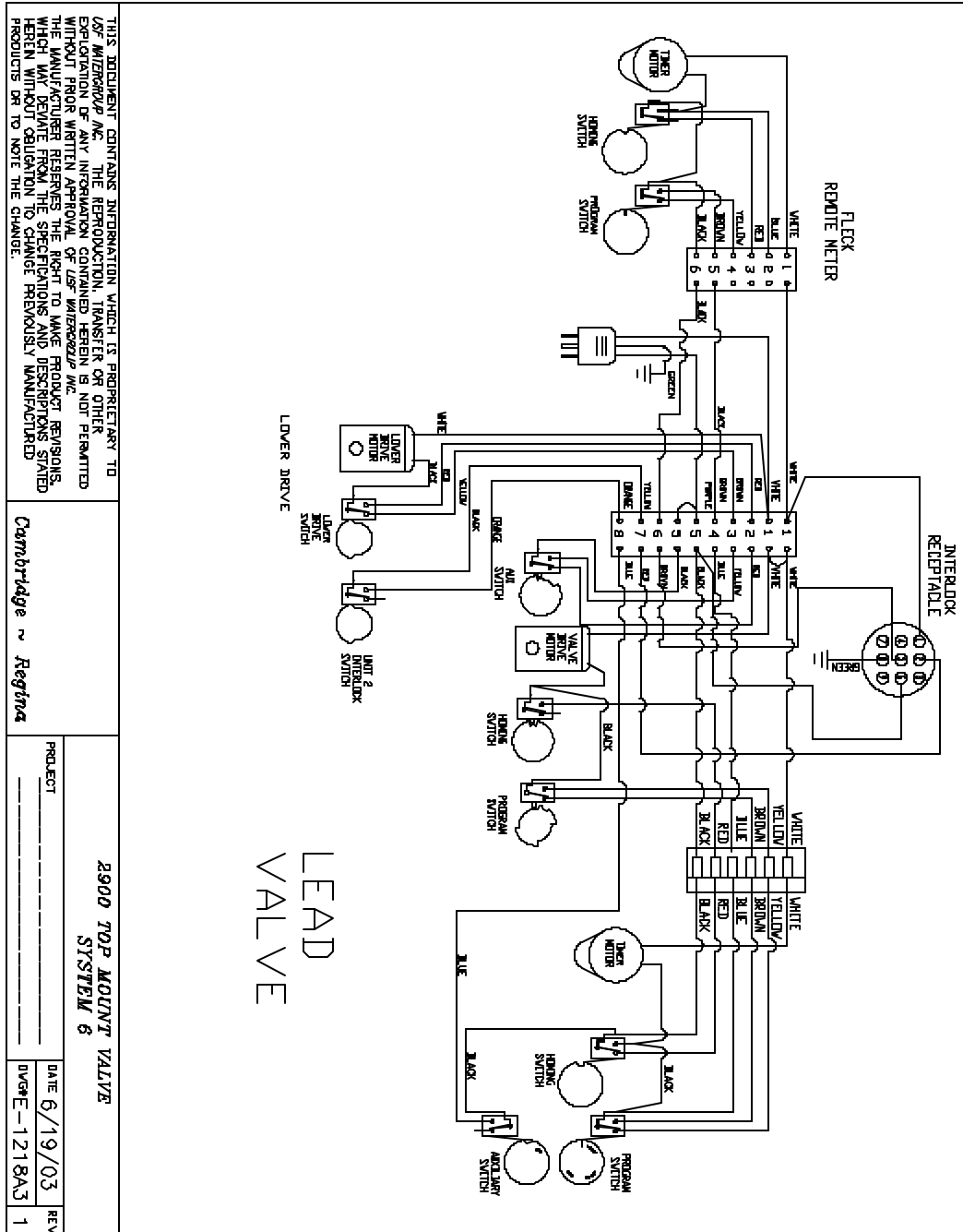

Note: U.S. companies should look at the Fleck manual for wiring diagrams

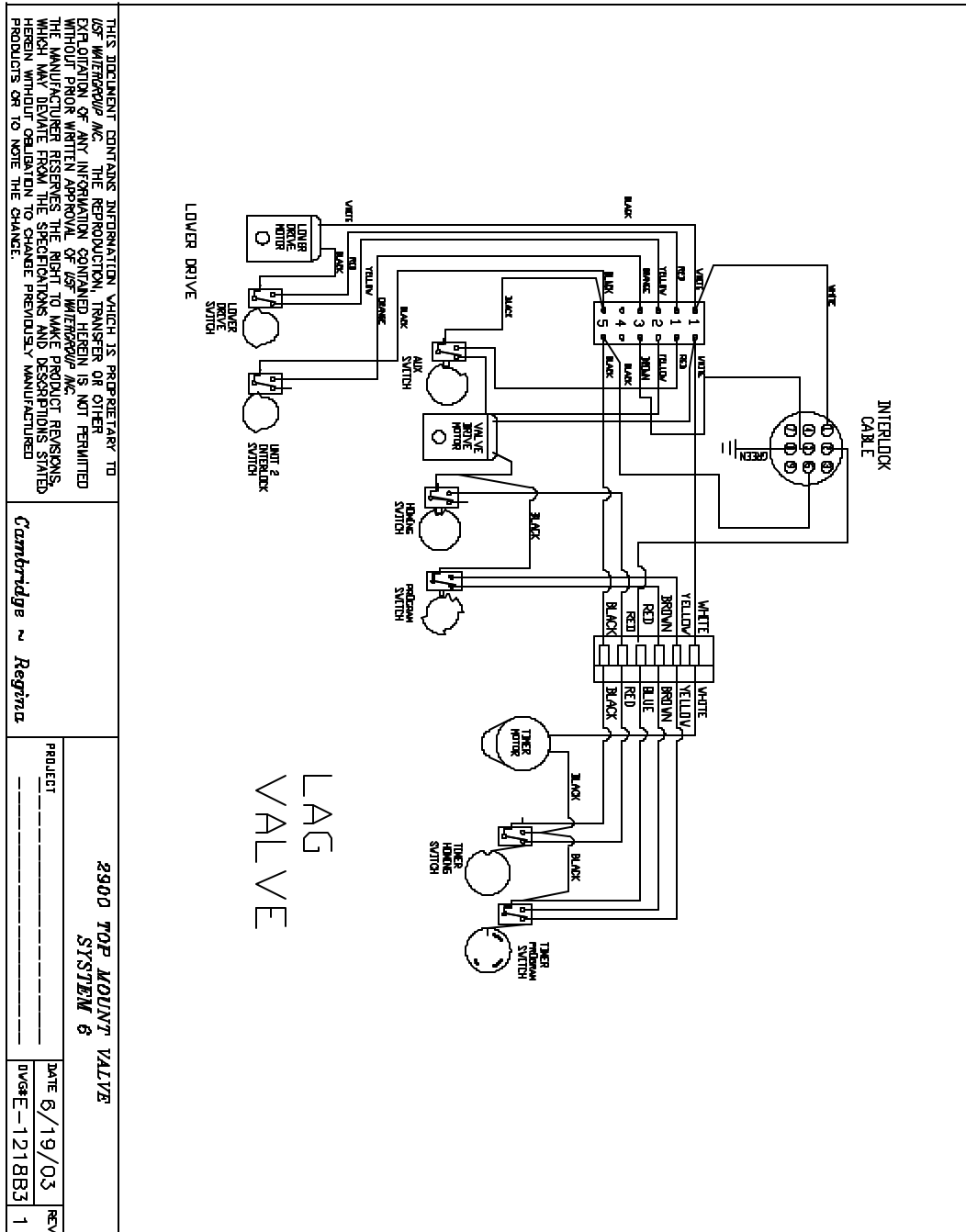

Note: U.S. companies should look at the Fleck manual for wiring diagrams

4.5.4 System 7 – Standard Duplex

System 7 is a meter initiated, duplex softener system, one on line with one in regeneration or standby. Regeneration is immediate.

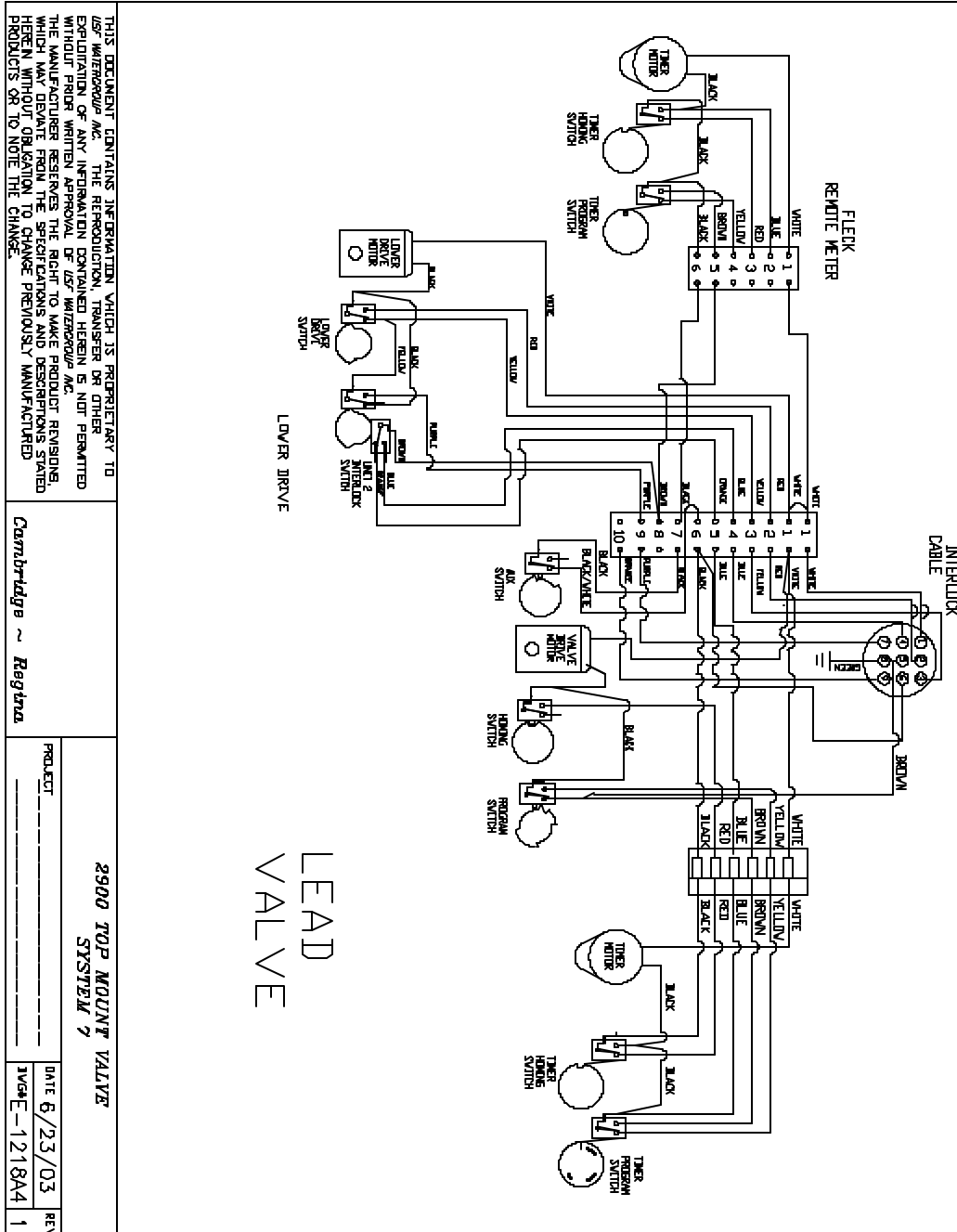

THIS DOCUMENT CONTAINS INFORMATION WHICH IS PROPRIETARY TO
 LEAD WATERWORKS, INC. THE REPRODUCTION, TRANSMISSION OR OTHER
 EXPLOITATION OF ANY INFORMATION CONTAINED HEREIN IS NOT PERMITTED
 WITHOUT PRIOR WRITTEN PERMISSION OF LEAD WATERWORKS, INC.
 THE INFORMATION HEREIN IS NOT TO BE USED IN ANY MANNER WHICH
 MAY DEPART FROM THE SPECIFICATIONS AND DESCRIPTIONS STATED
 HEREIN WITHOUT OBLIGATION TO CHANGE PREVIOUSLY MANUFACTURED
 PRODUCTS OR TO NOTE THE CHANGE.

Cambridge ~ Regina

2900 TOP MOUNT VALVE SYSTEM 7	
PRODUCT	DATE 6/23/03
	WWE-1218A4
	REV 1

Note: U.S. companies should look at the Fleck manual for wiring diagrams

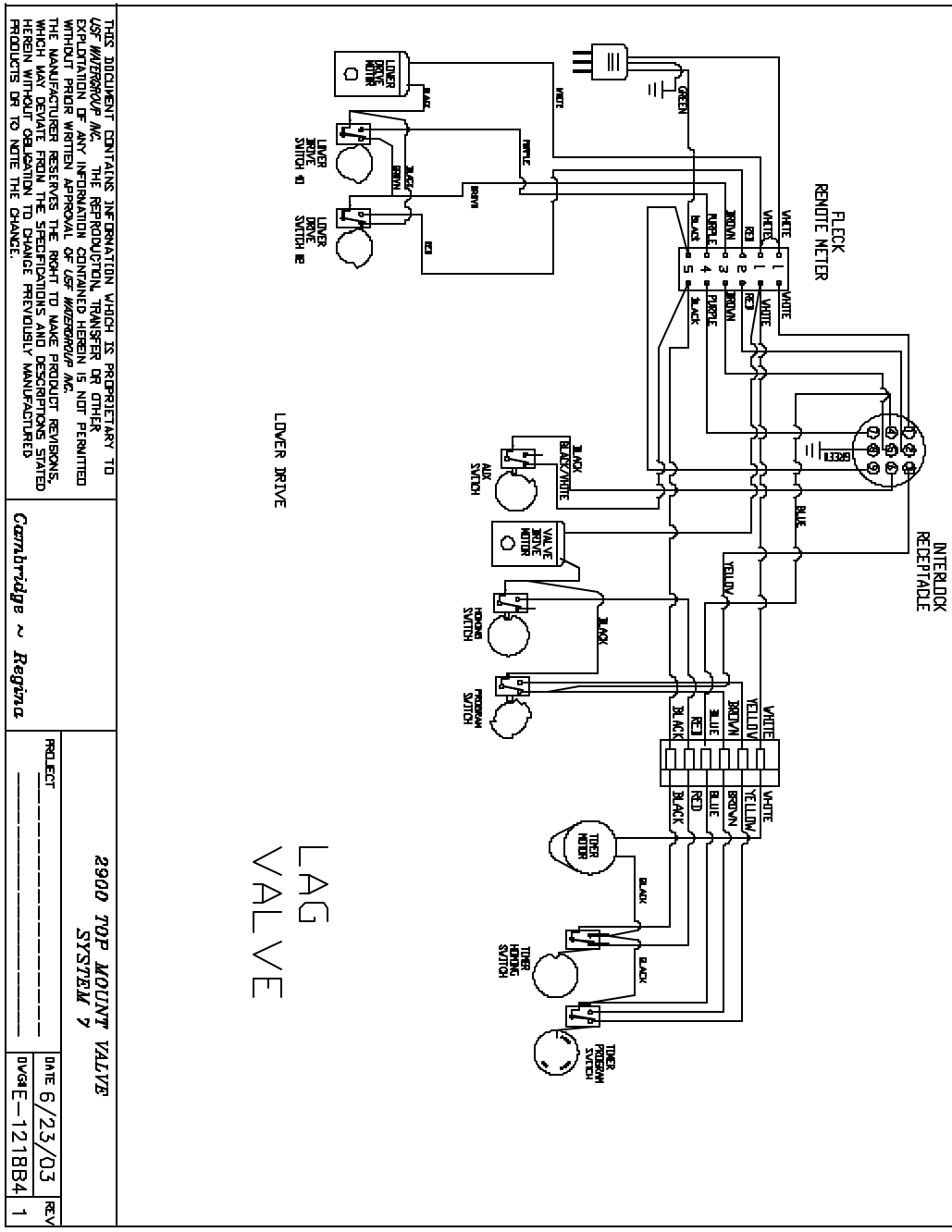

THIS DOCUMENT CONTAINS INFORMATION WHICH IS PROPRIETARY TO USF WATERWORKS INC. THE REPRODUCTION, TRANSFER OR OTHER EXPLOITATION OF ANY INFORMATION CONTAINED HEREIN IS NOT PERMITTED WITHOUT PRIOR WRITTEN APPROVAL OF USF WATERWORKS INC. THE MANUFACTURER RESERVES THE RIGHT TO MAKE PRODUCT REVISIONS, WHICH MAY DEVIATE FROM THE SPECIFICATIONS AND DESCRIPTIONS STATED HEREIN WITHOUT OBLIGATION TO CHANGE PREVIOUSLY MANUFACTURED PRODUCTS OR TO NOTE THE CHANGE.

Cambridge ~ Regina

2900 TOP MOUNT VALVE SYSTEM 7	
PROJECT _____	DATE 6/23/03
_____	DESIGNER-1218B4
_____	REV 1

Note: U.S. companies should look at the Fleck manual for wiring diagrams

Section 5. Media Specifications

Each softener size is based upon the volume of softening resin that is in the mineral tank. Each cubic foot of our standard softening resin is FDA approved for potable water and has a generic capacity of 30,000 grains (@15 lbs salt/ft³). This number is only approximate, and does vary depending upon the influent water quality. For example, an TMI 120 softener has 120,000 grains of generic capacity in each tank, i.e., four cubic feet of softening resin in each mineral tank. Note: Softeners are factory set for 10 lbs salt/ft³.

5.1 Media Description

Item #	Media	Description	Density (lb/ft ³)
1	Resin	Sybron C-249NS softening resin.	52
2	Fine Gravel	1/8" x 1/16" graded and washed quartz	100
3	Medium Gravel	1/4" x 1/8" graded and washed quartz	100
4	Coarse Gravel	1/2" x 1/4" graded and washed quartz	100

5.2 Softener Beds: *Quantities in cubic feet*

Softener Model	Tank Size	Resin 1 Volume	Fine 2 Gravel	Medium 3 Gravel	Coarse 4 Gravel	Part Number	Media Shipping Weight (lbs)
FAF45	10x54	1.5	0.16	0	0	410001	94
FAF 60	14x50	2	0.15	0	0.15	410002	134
FAF 90	14x65	3	0.15	0	0.15	410003	186
FAF 120	16x65	4	0.15	0	0.20	410004	243
FAF 150	21x54	5	0.15	0.15	0.20	410005	310
FAF 180	21x54	6	0.15	0.15	0.20	410006	362
FAF 210	21x69	7	0.15	0.15	0.20	410007	414
FAF 240	21x69	8	0.15	0.15	0.20	410008	466
FAF 270	24x72	9	0.20	0.20	0.30	410009	538
FAF 300	24x72	10	0.20	0.20	0.30	410010	590
FAF 330	24x72	11	0.20	0.20	0.30	410011	642
FAF 360	30x72	12	0.35	0.35	0.40	410012	734
FAF 390	30x72	13	0.35	0.35	0.40	410013	786
FAF 450	30x72	15	0.35	0.35	0.40	410015	890
FAF 510	30x72	17	0.35	0.35	0.40	410017	994
FAF 570	36x72	19	0.50	0.50	0.70	410019	1158
FAF 600	36x72	20	0.50	0.50	.070	410020	1210
FAF 630	36x72F	21	0.50	0.50	0.70	410021	1262
FAF 660	42x72F	22	1.50	1.50	2.20	410022	1664
FAF 720	42x72F	24	1.50	1.50	2.20	410024	1768
FAF 780	72x72F	26	1.50	1.50	2.20	410026	1872
FAF 900	48x72F	30	2.00	2.00	2.20	410030	2180
FAF 1020	48x72F	34	2.00	2.00	2.20	410034	2388
FAF 1080	48x72F	36	2.00	2.00	2.20	410036	2492
FAF 1740	63x86	58	8.00	8.00	7.00	410058	5316

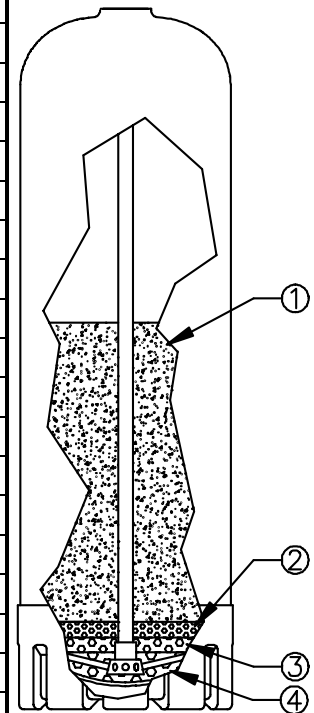

Section 6. 2900 Valve Softener Parts Breakdown

Note: Unit shown with Environmental Enclosure which is standard on ET and Systemax units. Standard mechanical units equipped with standard enclosure.

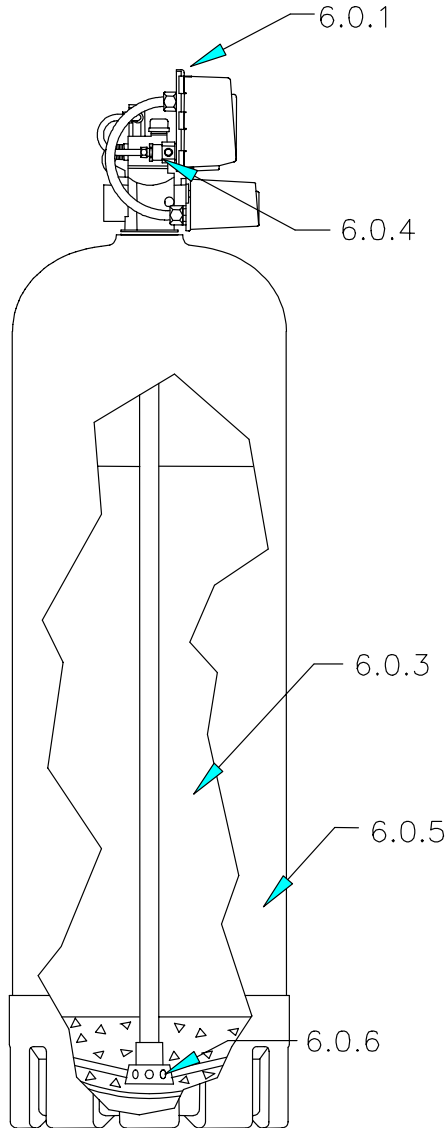

Fig. 6.1 Softener Unit

6.0.1 Control Valves:

Valves	Part Number 1600 Brine System	Part Number 1700 Brine System
2900 CC Single	290001	290011
2900 CC Duplex	290002	290012
2900 Systemax Single	290003	290013
2900 Single MI Sys 4	290004	290014
2900 Duplex MI Sys 5	290005	290015
2900 Duplex MI Sys 6	290006	290016
2900 Duplex MI Sys 7	290007	290017
2900 Single Sensor	290008	290018
2900 Duplex Sensor	290009	290019

All above valves require the appropriate valve kit (see 6.0.8) which includes the backwash flow control, injectors and refill flow control. Backwash flow controller brass bushing may be required 1" x 3/4" (not shown) #12702. For system descriptions, see Section 1 Product summary

6.0.2 Remote Meters, (not shown, System 6 & 7 MI initiated units only)

Meter Size	Part Number	Flow Range	Gal. Range
2" Std. Range	17527	3-150 USGPM	1,250-21,250
2" Ext. Range	Special	3-150 USGPM	6,250-106,250
2" ET w/o Timer	60616	3-150 USGPM	N/A
3" Std. Range	17859	7-300 USGPM	3,750-63,750
3" Ext. Range	Special	7-300 USGPM	18,750-318,750
3" ET w/o Timer	60617	7-300 USGPM	N/A

6.0.3 Media Bed: See section 5.2.3 for part numbers

6.0.4 SVO, only. (Service Valve Operator): (for treated water regeneration) #13920.

6.0.5 Tank: See following table in 6.0.8

6.0.6 Distribution: See table in 6.0.8

6.0.7 Accessories (not shown)

Treated water regen backwash diaphragm valve kit (requires SVO)

- includes one N.O. & one N.C. 2" diaphragm valves # 19610

Brine Tank air checks-1600 series (FAF 120 & smaller) #13910

-1700 series (FAF 150 & larger) #19999

Section 6.0.8 2900 Valve

Softener Model	Tank Size	Tank	Dist.	Brine Tank Size	Standard Brine Tank	Safety Float Brine Tank	Valve Kit
FAF 60	14x50	114506	61000	21x36	410302	P410502	430501
FAF 90	14x65	114656	61000	21x36	410303	P410503	430801
FAF 120	16x65	116656	61000	21x36	410304	P410504	431101
FAF 150	21x54	100416	61001	24x48	410305	P410505	431401
FAF 180	21x54	100416	61001	24x48	410306	P410506	431701
FAF 210	21x69	100423	61001	24x48	410307	P410507	432001
FAF 240	21x69	100423	61001	24x48	410308	P410508	432301
FAF 270	24x72	100424	61001	24x48	410309	P410509	432601
FAF 300	24x72	100424	61001	24x48	410310	P410510	433001
FAF 330	24x72	100424	61001	24x48	410311	P410511	433401
FAF 360	30x72	100425	61002	30x48	410312	P410512	433701
FAF 390	30x72	100425	61002	30x48	410313	P410513	434101
FAF 450	30x72	100425	61002	36x48	410315	P410515	434901
FAF 510	30x72	100425	61002	36x48	410317	P410517	435701
FAF 570	36x72	100429	61003	36x48	410319	P410519	436201
FAF 600	36x72	100429	61003	42x48	410320	P410520	436401
FAF 630	36x72	100429	61003	42x48	410321	P410521	436601

Section 6.1.0 2900 Typical Upper Control Drive Assembly

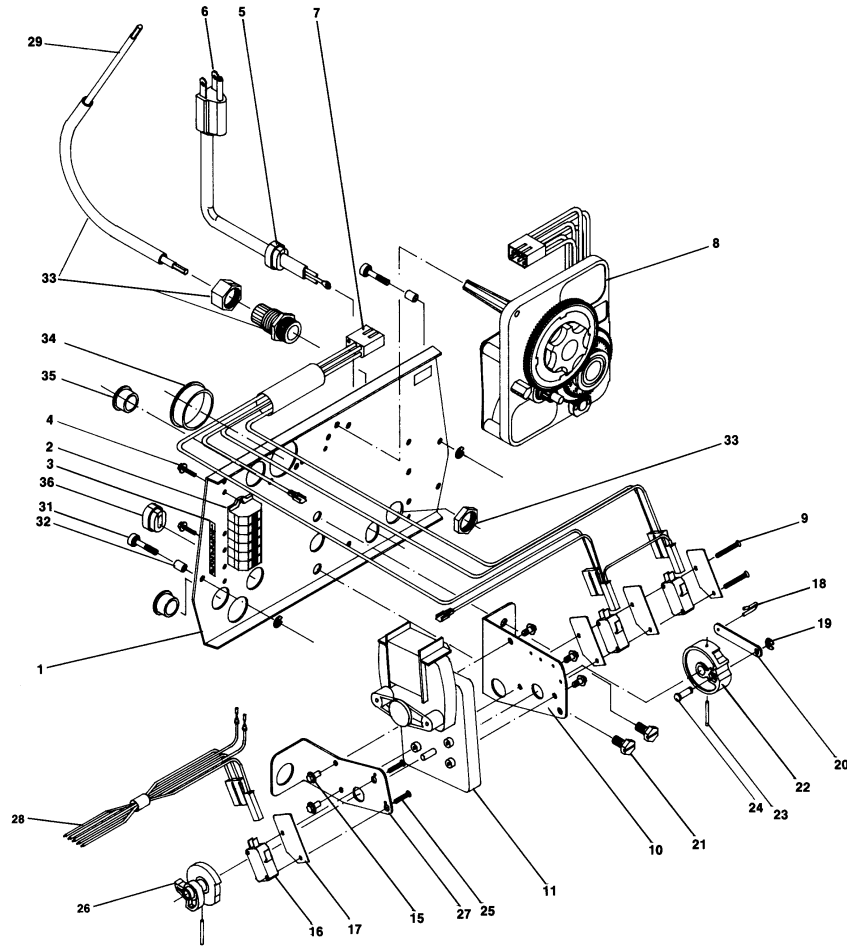

Section 6.1.0 2900 Typical Upper Control Drive Assembly

ITEM NO.	NO.REQ'D.	PART NO.	DESCRIPTION
1	1	15156	Back Plate
		11828	Wide Slant Front Back Plate(Not Shown)
2	1	15226-6	Terminal Block
3	2	15250	Label-Terminal Block
4	2	10299	Screws-Terminal Block-#6-20x1/2"
5	1	13547	Strain Relief
6	1	11842	Power Cord
7	1	11667	Wire Harness
8	1		Timer Assembly -Specify 3000,3200,or3210 SERIES
9	2	14923	Micro Switch Screw-#4-40x1"
10	1	10774	Motor Bracket
11	1	10769	Motor 120V., 60Hz.

	1	40385	Motor 24V
12	1	14779	Designer Cover Assembly (Not Shown)
15	5	10872	Motor Mount Screw-#8-32x5/16"
16	3	10218	Micro Switch
17	3	10302	Insulator
18	1	10909	Connecting Rod Clip
19	3	10250	Retaining Ring
20	1	10621	Connecting Rod
21	2	10231	Drive Mount Screw
22	1	12576	Drive Cam-Separate Time Fill
	1	12576-02	Drive Cam for the 2900S Valve
23	2	10338	Drive Roll Pin
24	1	13366	Drive Bearing
25	2	11805	Micro Switch Screw
26	1	12777	Brine Valve Cam
27	1	11826	Motor Bracket-Brine Side
28	1	14822	Motor Lead Wires-Pigtail
29	1	15216	Meter Cable
31	2	15742	Cover Screw
32	2	15833	Spacer
33	1	15879	Cable Guide,Assembly
34	1	17421	Plug,Heyco
35	2	13741	Plug,Heyco
36	1	15602	Strain Relief,Harness
37	2	10300	Screw,Timer Mounting-Not Shown
38	2	12732	Nut,Terminal Block,Mounting-Not Shown
39	1	19291-020	Cover,1 Piece,Black-Not Shown
40	2	19367	Screw,Cover-Not Shown
	1	19010	9 Pin Receptacle (Lead and Middle Valves Only)
	1	19009	9 Pin Cable (Middle and Lag Valves Only)

Section 6.1.1 2900 Typical Lower Control Drive Assembly

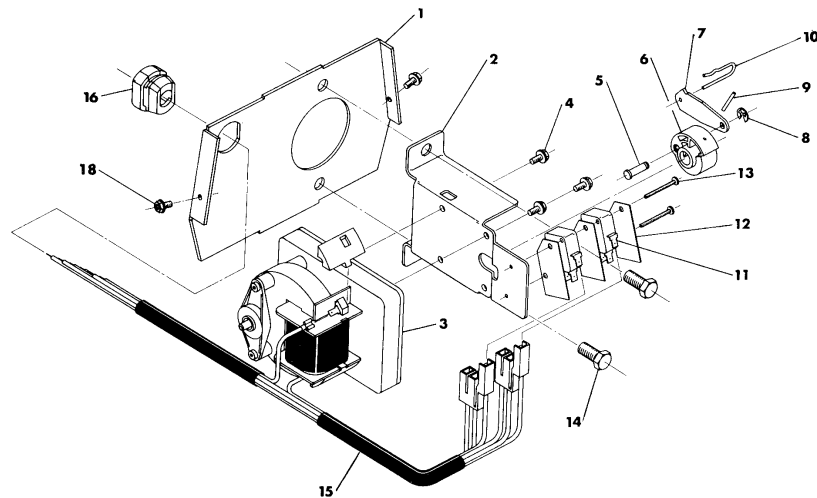

Section 6.1.1 2900 Typical Lower Control Drive Assembly

ITEM NO.	NO.REQ'D.	PART NO.	DESCRIPTION
1	1	14770	Back Plate
2	1	14769	Motor Bracket
3	1	14772	Motor-110V.,60Hz.
	1	40388	Motor 24V
4	4	10872	Screw-Motor Mtg.
5	1	14784	Connecting Rod Bearing
6	1	14775	Drive Cam
7	1	14759	Piston Drive Link
8	1	10250	Retaining Ring
9	1	11381	Pin Drive Cam Mtg.
10	1	14813	Spring Clip
11	1	10218	Micro Switch-System 4
	2	10218	Micro Switch-System 5,6,7
12	2	10302	Insulator-System 4
	3	10302	Insulator-Systems 5,6,7
13	2	11805	Screw, Micro Switch-system 4
	2	14923	Screw-Micro Switch-systems 5,6,7
14	2	11224	Screw-Drive Mounting
15	1	15926	Wire Harness #4
	1	14827	Wire Harness #5 & #6
	1	15938	Wire harness #7-Lead Valve
	1	15936	Wire harness #7 Lag Valve
16	1	14924	Strain Relief
17	1	14800	Cover
18	2	15236	Screw Assy-Cover
NOTE: For System 7 Lead Only, Add			
	1	10218	Micro Switch(Not Shown)
	2	10302	Insulator(Not Shown)
	2	11805	Mtg.Screw(Not Shown)
	1	15713	Mtg.Plate(Not Shown)
	1	16103	Insulator(Not Shown)
	2	11413	Mtg. Screw(Not Shown, replaces 14923)

Section 6.2 2900 Valve Timer Assembly

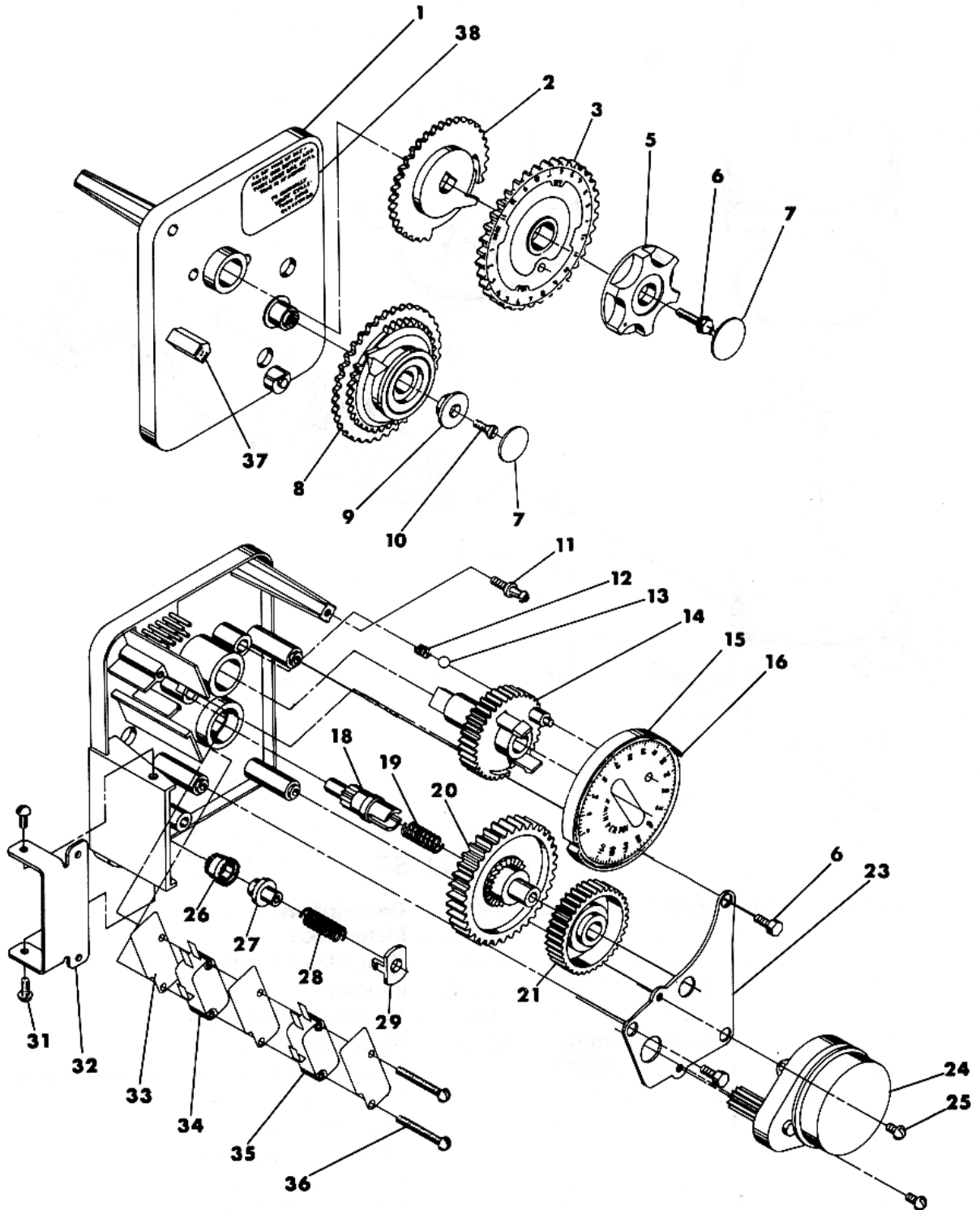

Section 6.2 2900 Valve Timer

ITEM NO.	NO.REQ'D	PART NO.	DESCRIPTION
1	1	13870-01	Timer Housing Assembly
2	1	13802	Cycle Actuator Gear (Domestic Only)
	1	13011	Cycle Actuator Gear (All Filter Systems)
3	1	19205	24 Hour Gear Assembly, Silver
		19205-01	24 Hour Gear Assembly, Tan (Delay Valve: Specify Regeneration Time usually 2:00 AM)
4	1	13886-01	Knob
6	4	13296	Screw-Timer Knob & Motor Plate Mtg.
7	2	11999	Button Decal
8	1	60405-30	Program Wheel Assembly
9	1	13806	Program Wheel Retainer
10	1	13748	Screw-Program Wheel Mtg.
11	1	14265	Spring Clip
12	1	15424	Spring-Detent (Delay Only)
13	1	15066	Ball-1/4 in. dia. (Delay Only)
14	1	13911	Main Drive Gear (Delay Only)
	1	15055	Main Drive Gear (Immediate)
15	1	19210	Program Wheel (Delay Only)
	1	13880-02	Program Wheel (Immediate)
16	21	15493	Roll Pin
18	1	13018	Idler Shaft
19	1	13312	Spring-Idler
20	1	13017	Idler Gear
21	1	13164	Drive Gear (Wide)
	1	15275	Drive Gear (Narrow)
23	1	13887	Motor Mounting Plate
24	1	13944	Motor-110V.,60Hz
		14104	Motor-24V.,60Hz.
25	3	13278	Screw-Motor Mounting & Ground Wire
26	1	13830	Drive Pinion-Program Wheel
27	1	13831	Clutch-Drive Pinion
28	1	14276	Spring
29	1	14253	Spring Retainer
30			Not Assigned
31	2	11384	Screw-Timer Hinge
32	1	13881	Hinge Bracket
33	3	14087	Insulator
34	1	10896	Switch (1/2 Moon)
	1	15314	Switch (Modified Metal Tip)
35	1 Or 2	15320	Switch (White Tip)
36	2	11413	Screw-Switch Mounting
37	1	14007	Decal-Time of Day
38	1	14045	Decal-Instructions (Delayed Valve Only)
	1	14198	Decal-Meter Label Indicator
	1	15148	Decal-(To Manually Start...)
	1	15313	Decal-Instructions (Warning)
	1	15465	Decal-Instructions (MI Valve Caution)

39	1		Timer Motor Harness-Specify Valve, System & Position (Lead, Lag, Etc)
40	2	12681	Wire Connector-Not Shown
41	1	15354-01	Ground Wire-Not Shown
	1	14381	12 Day Standard CC Skipper Wheel (Not Shown)
	1	14860	7 Day CC Skipper Wheel (Not Shown)
	1	13864	Skipper Wheel Ring (Not Shown)
	2	13311	Skipper Wheel Spring (Not Shown)
	2	13300	Skipper Wheel Ball (Not Shown)
	1	14381	Skipper Wheel Pointer (Not Shown)
	1	13296	Skipper Wheel Screw (Not Shown)
	1		Timer Assembly CC Valve (specify valve)
	1		Timer Assembly System 4 (specify valve)
			Timer Assembly System 5 (specify valve)
			Timer Assembly System 6 (specify lead or lag valve)
	1		Timer Assembly System 7 (specify valve)

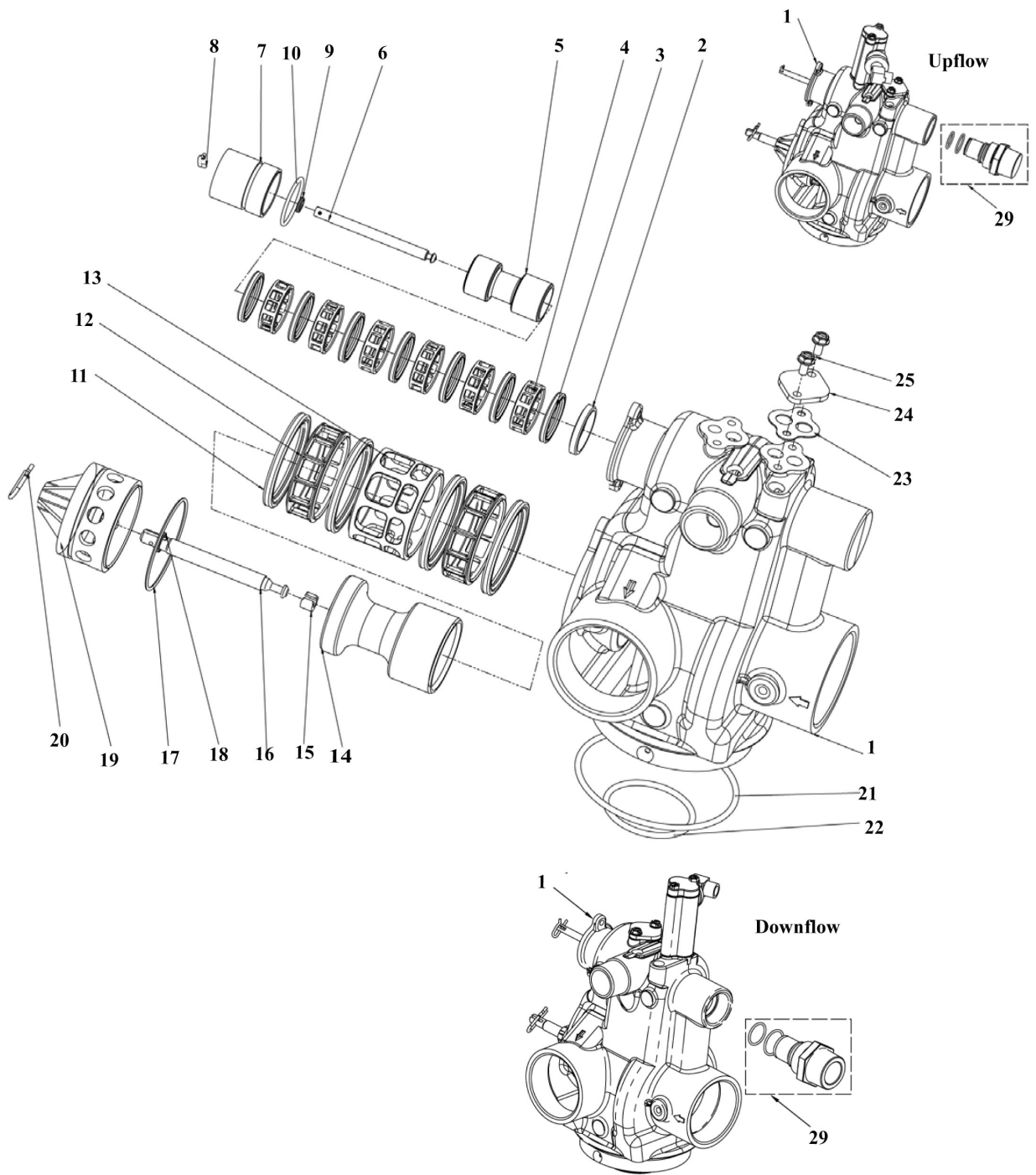

Section 6.3A 2900S Valve Body Assembly

CONTROL VALVE PARTS LIST

ITEM NO.	QUANTITY	PART NO.	DESCRIPTION
1	1	41428	2900S Valve Body
		41428-11	2900S Valve Body with Soft Water Adapter
2	1	10757	End Spacer
		10757B	End Spacer, Hot Water
3	6	10545	Piston Seal
		10545-01	Piston Seal, Viton
		10545-02	Piston Seal, Silicone
4	5	11451	12 Hole Spacer
		16589	Spacer, Hot Water
5	1	14451	Upper Drive Piston
6	1	41424	Piston Rod
7	1	41131	End Plug
8	1	10909	Pin, Link
9	1	10209-01	Quad Ring, 010
10	1	10234-01	O-ring
11	1	11720	Piston Seal
12	1	14241-01	2" Spacer, HW
13	1	14753	Spacer, 2900
		16589	Spacer, HW
14	1	14757	Piston, HWBP
		14752	Piston, NHWBP
15	1	14818	Piston Ring
16	1	14758	Piston Rod
17	1	14922	O-ring, 035
18	2	14926	Quad Ring, 012
19	1	14754-00	End Plug Assy
		14754-10	End Plug Assy, NHWBP
20	1	14813	Pin, Spring, Connecting Rod
21	1	113575	O-ring, 240
		15210	O-ring, 343
22	2	13577	O-ring, 226
23	1	19925	Gasket, Injector Body, 1700 Regulator
24	1	11893	Cap, Injector, SS
25	1	15137	Screw
29	1	61525	Softwater Adapter Kit, 2900S

Section 6.3A 2900 Valve Body

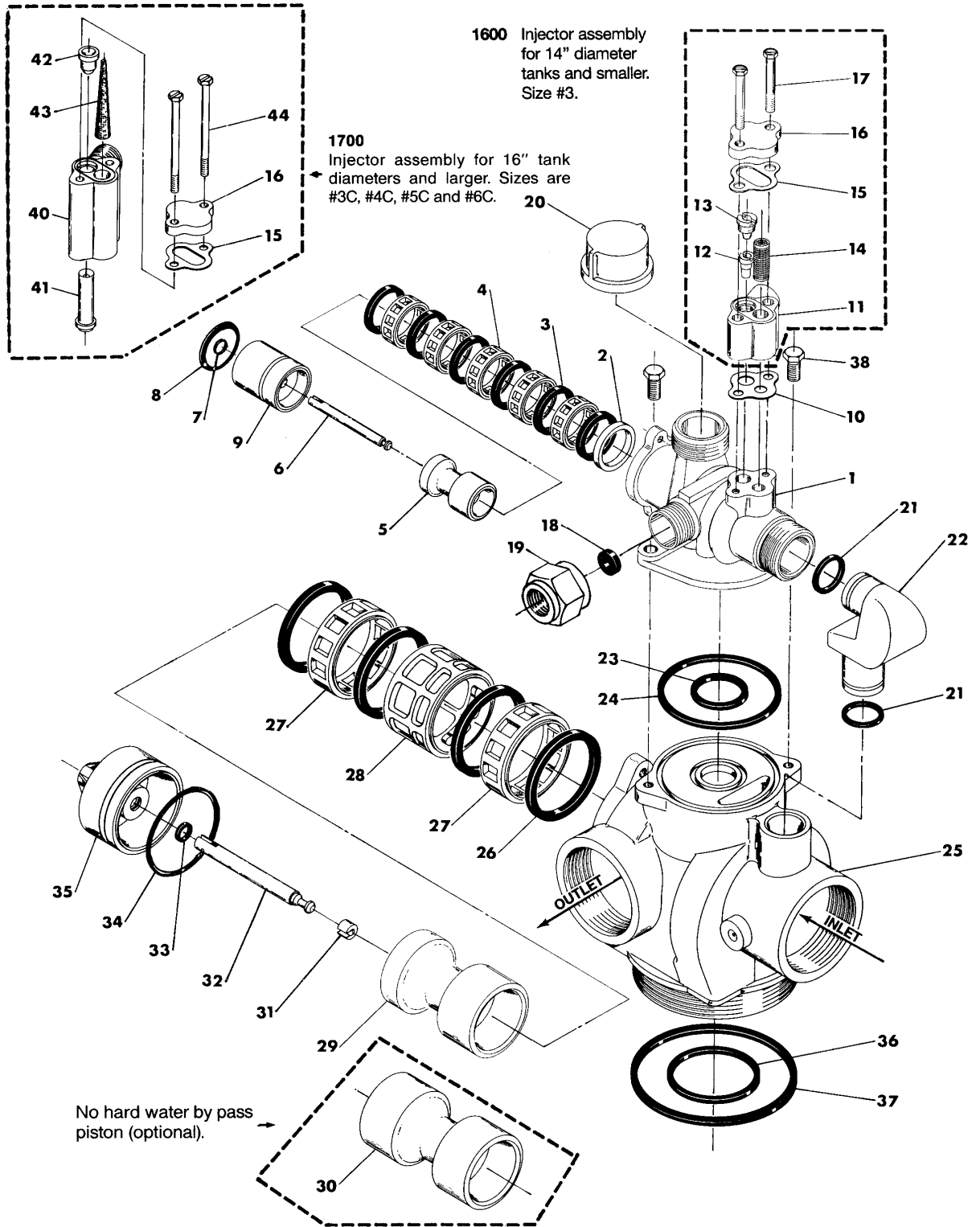

Section 6.3A 2900 Valve Body Assembly

CONTROL VALVE PARTS LIST

ITEM NO.	QUANTITY	PART NO.	DESCRIPTION
1	1	14749	Valve Body
2	1	10757	End Spacer
		10757B	End Spacer,Hot Water
3	6	10545	Seal
4	5	11451	Spacer
		16589	Spacer,Hot Water
5	1	14451	Piston
6	1	14452	Piston Rod
7	1	10209	Quad Ring-Piston Rod
8	1	10234	“O”Ring-End Plug
9	1	10598	End Plug Assembly
		10598-01	End Plug Assembly,Hot Water
10	1	14805	Injector Body Gasket
11	1	17776	Injector Body
12	1	10914-3	Injector Throat #3,Yellow
		10226-03	Injector Throat #3,Hot Water
13	1	10913-3	Injector Nozzle #3,Yellow
		10225-03	Injector Nozzle #3,Hot Water
14	1	10227	Injector Screen
15	1	10229	Injector Cover Gasket
16	1	11893	Injector Cover
17	2	10692	Screw-Injectory Body
18	1		Washer-Flow Control-Specify Size
19	1	15177	Flow Control Housing
20	1	12248	1”NPT Pipe Cap
21	2	14812	“O”Ring Coupling
22	1	14751	Coupling
23	1	11710	“O”Ring-Regeneration Port
24	1	11208	“O”Ring-Regeneration Port
25	1	14750	2” Adapter Valve
26	4	11720	Seal
27	2	10369	Spacer
		16141	Spacer,Hot Water
28	1	14753	Spacer
		16142	Spacer,Hot Water
29	1	14757	Piston
30	1	14752	Piston-No Hard Water By-Pass
31	1	14818	Piston Rod Clip
32	1	14758	Piston Rod
33	1	14926	Quad Ring-Piston Rod
34	1	14922	“O”Ring-End Plug
35	1	14754-00	End Plug Assembly(White)
		14754-10	End Plug Assembly-No Hard Water By-Pass(Black)
		19276	End Plug Assembly-Hot Water
36		13577	“O”Ring-Distributor
37	1	13575	“O”Ring-Top of Tank
	1	15210	“O”Ring-Top of “Park” Tank
38	1	11224	Screw-Valve Mounting
39	2		Not Assigned

40		17777	Injector Body
41	1	*14802	Injector Throat
42	1	*14801	Injector Nozzle
43	1	14803	Injector Screen
44	1	14804	Screw-Injector Body
45	2	16221	Air Disperser-1600 Injector(not shown)
46	1	19608-15	Disperser,Upper(not shown)
	1	15170	Elbow (not shown, used with meter initiated)

*Injector Throat	*Injector Nozzle	Size	Color
14802-03	14801-03	#3C	Yellow
14802-04	14801-04	#4C	Green
14802-05	14801-05	#5C	White
14802-06	14801-06	#6C	Red

Section 6.4.0 1600 Series Brine Valve Assembly #13804

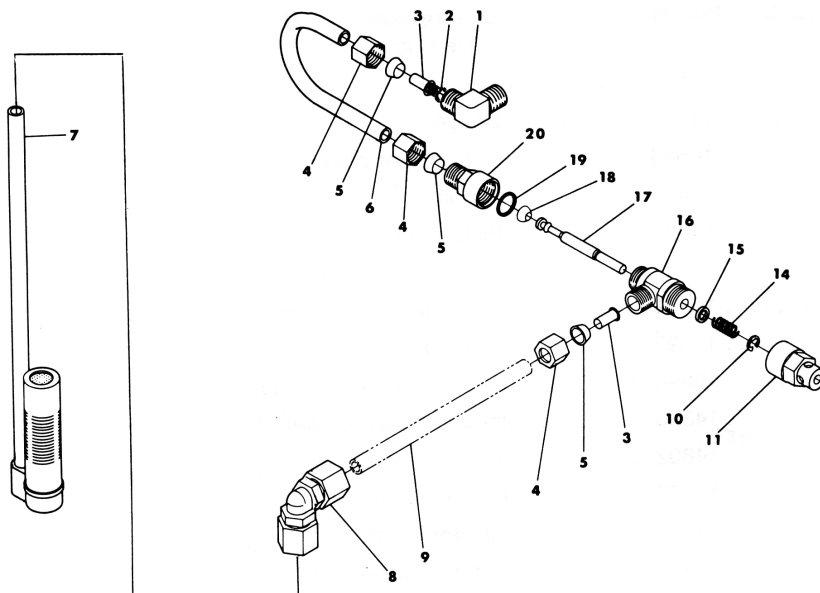

ITEM NO.	QUANTITY	PART NO.	DESCRIPTION
1	1	10328	90degree Elbow-1/4 Pipe Thd. to 3/8 Tube
2	1	12767	Brine Line Screen
3	2	10332	Insert Sleeve(3/8 Tube)
4	3	10329	Fitting Nut(3/8 Tube)
5	3	10330	Derlin Sleeve (3/8 Tube)
6	1	15221	Brine Valve Tube
	1	16460	2900S Brine Valve Tube (Single Cast Valve)
7	1	60002	#500 Air Check Assembly
		60003	#500 Air Check Assembly,Hot Water
8	1	12794	90degree Elbow-3/8 Tube to 3/8 Tube
9	1	Not Supplied	Brine Line Tube(3/8 Flexible Tube)
10	1	10250	Retaining Ring
11	1	11749	Stem Guide
12	1		Not Assigned
13	1		Not Assigned
14	1	10249	Brine Valve Spring
15	1	12550	Quad Ring

16	1	12748	Brine Valve Body
17	1	12552	Brine Valve Stem
18	1	12626	Brine Valve Seat
19	1	11982	"O"Ring
20	1	60020-25	BLFC .25GPM
		60020-50	BLFC .50GPM
		60020-100	BLFC 1.0GPM
	1	13805	Assembly includes #10, 14 to 18
	1	13804	Assembly includes 13805 + 11, 19, & 20 (1.0 GPM)

Section 6.4.1 1700 Series Brine Valve Assembly #19497

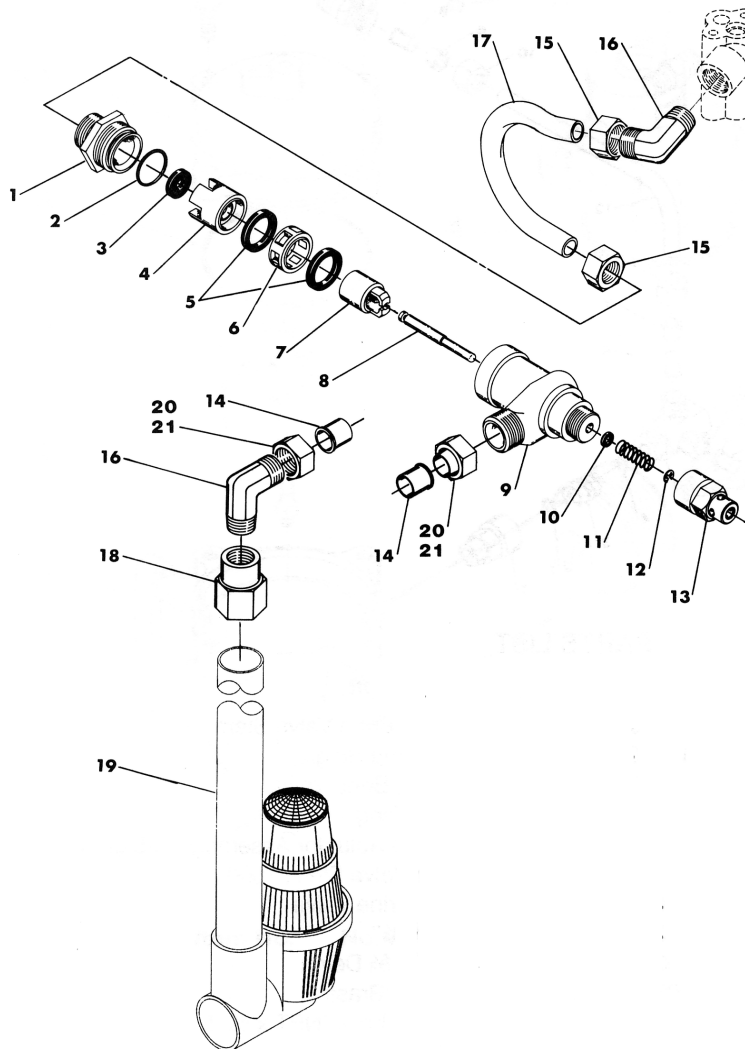

Section 6.4.1 1700 Series Brine Valve Assembly

ITEM NO.	NO.REQ'D.	PART NO.	DESCRIPTION
1	1	14792	End Plug
2	1	13201	“O”Ring-End Plug
3	1		Washer Flow Control(specify size)
4	1	14785	Flow Control Retainer
5	2	14811	Piston Seals
6	1	14798	Spacer
7	1	14795	Brine Valve Piston
8	1	14797	Brine Valve Stem
9	1	14790	Brine Valve Body
10	1	12550	Quad Ring-Brine Stem
11	1	15310	Spring-Brine Valve
12	1	10250	Retaining Ring
13	1	15517	Stem Guide
14	2	15415	Insert
15	2	15414	Nut & Sleeve
16	2	15413	Elbow
17	1	15416	Brine Tube
18	1	16977	Reducer Coupling,1/2NPT to 3/8 NPT
19	1	19999	#900 Air Check Assembly
20	2	16123	Nut
21	2	16124	Sleeve
	1	19497	Assembly includes #1 to 13, and 15 to 18

Section 6.5 2900 Valve Service Valve Operator (SVO)

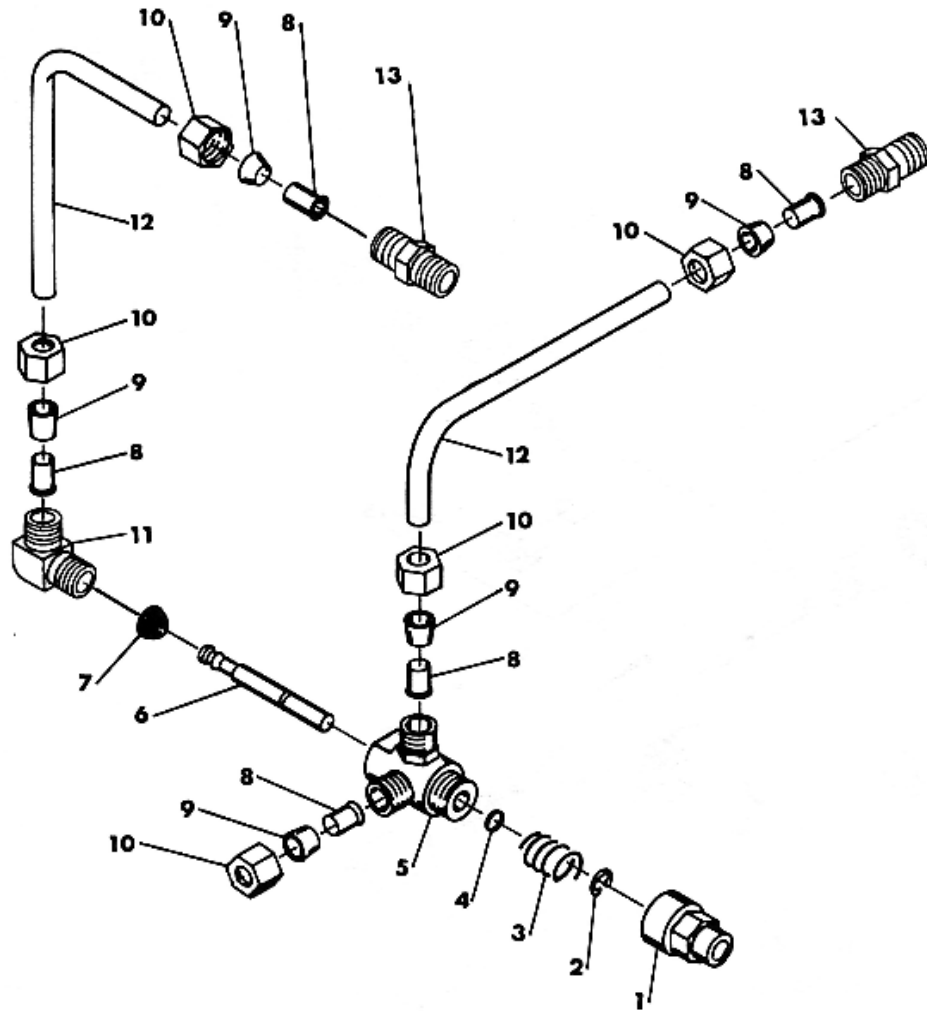

SERVICE VALVE OPERATOR PARTS LIST

<u>ITEM NO.</u>	<u>NO.REQ'D</u>	<u>PART NO.</u>	<u>DESCRIPTION</u>
1	1	11749	Guide,Brine Valve Stem
2	1	10250	Retaining Ring
3	1	10249	Spring,Brine Valve
4	1	12550	Quad Ring
5	1	10785	Service Actuator Assembly-.25gpm
6	1	12552	Brine Valve Stem,1600
7	1	12626	Seat,Brine Valve
8	5	10332	Insert,3/8"
9	5	10330	Sleeve,3/8 Delrin
10	5	10329	Nut,3/8" Brass
11	1	10328	Elbow,90 1/4"NPTx3/8"T
12	2	12897	Tube
13	2	16730	connector,Male1/8"NPT to 3/8"T
	1	13920	Assembly includes #2 to 7

Section 6.6 2" Meter Assembly

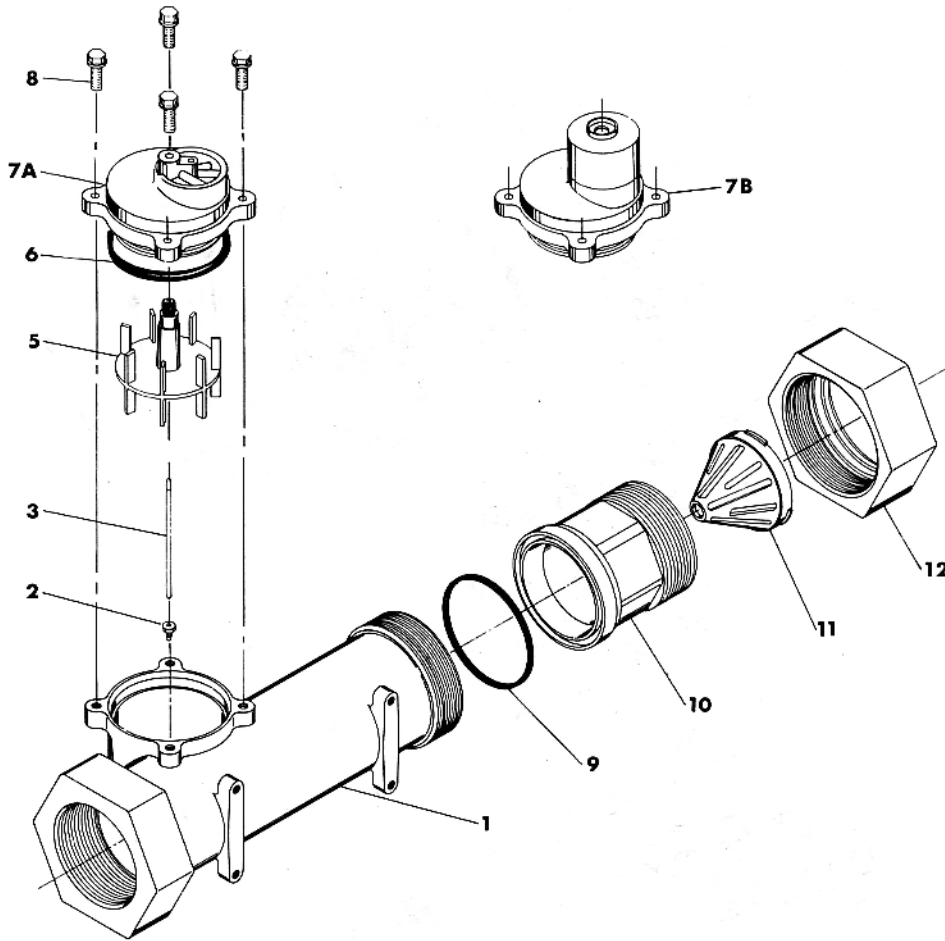

ITEM NO.	NO.REQ'D	PART NO.	DESCRIPTION
1	1	14456	Meter Body
2	1	15532	Impeller Shaft Retainer
3	1	15432	Impeller Shaft
4	1		Not Assigned
5	1	15374	Impeller
6	1	13847	"O" Ring-Meter Cover
7A	1	15218	Meter Cover Assembly(Standard)
7B	1	15237	Meter Cover Assembly(Extended Range)
8	4	12112	Screw-Meter Cover
9	1	14679	"O" Ring-Quick Connect
10	1	14568	Nipple-Quick Connect
11	1	14680	Flow Straightener
12	1	14569	Nut-Quick Connect

Section 6.7 Remote Meter Immediate Regeneration Mechanical Timer Assembly (Standard)

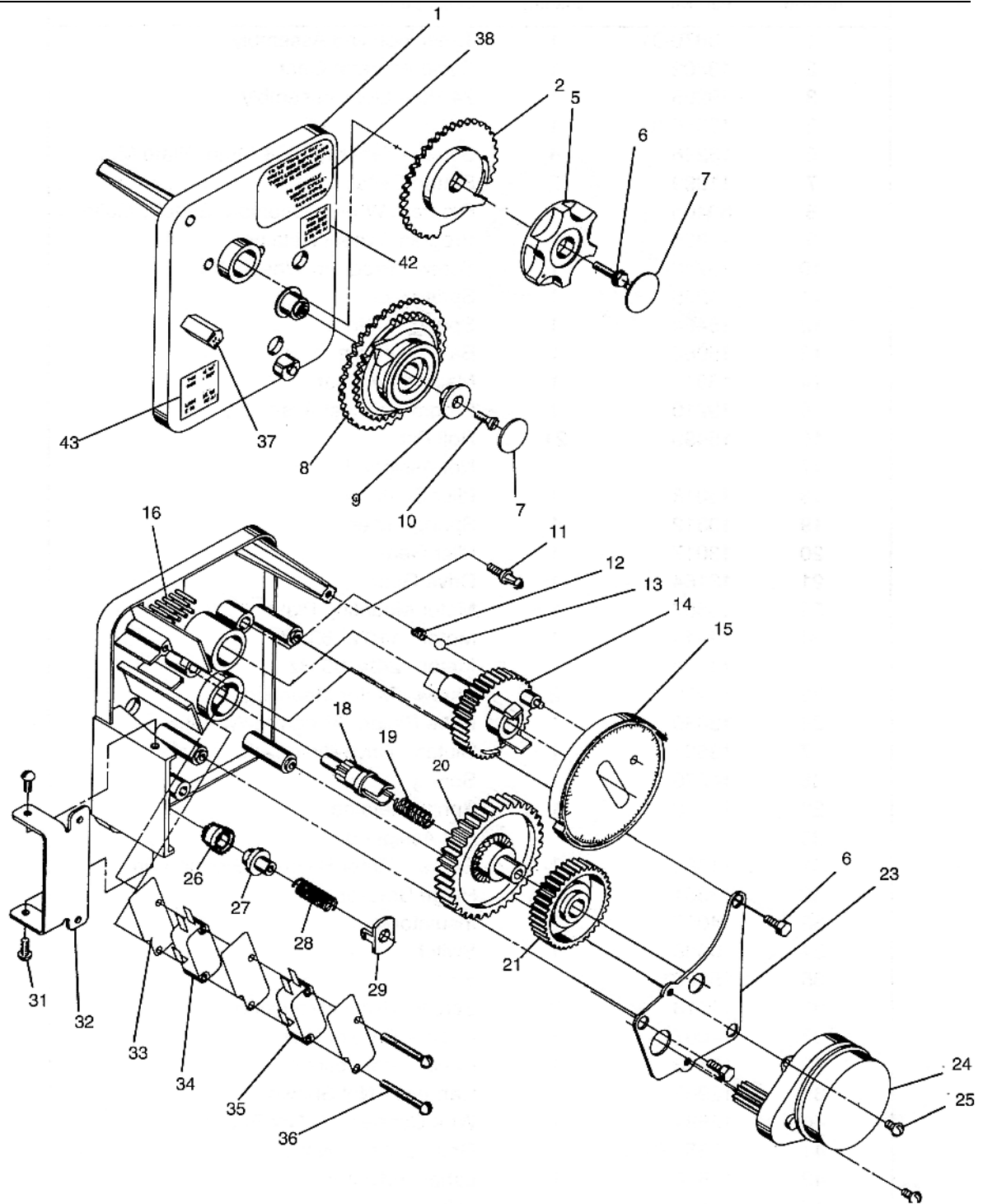

Section 6.7 Remote Meter Immediate Regeneration Mechanical Timer Assembly

IMMEDIATE REGENERATION TIMER ASSEMBLY

ITEM NO.	PART NO.	QUANTITY	DESCRIPTION
1	13870-01	1	Timer Housing Assembly
2	15431	1	Cycle Actuator Gear
5	13886-01	1	Knob
6	13296	4	Screw-Timer Knob & Motor Plate Mtg.
7	11999	2	Button Decal
8	60405	1	Program Wheel Assembly,Specify Gallons
9	13806	1	Program Wheel Retainer
10	13748	1	Screw-Program Wheel Mtg.
11	14265	1	Spring Clip
12	15424	1	Spring Detent
13	15066	1	Ball-1/4in. dia.
14	15055	1	Main Drive Gear
15	13880-04	1	Program Wheel 1RPM
16	15493	10	Roll Pin
17			Not Assigned
18	13018	1	Idler Shaft
19	13312	1	Spring Idler
20	13017	1	Idler Gear
21	13164	1	Drive e Gear
23	13887	1	Motor Mounting Plate
24	14974	1	Motor-110V.,60Hz.,1RPM
25	13278	2	Screw-Motor Mounting
26	14502	1	Drive Pinion-Program Wheel
27	14501	1	Clutch-Drive Pinion
28	14276	1	Spring
29	14253	1	Spring Retainer
30			Not Assigned
31	11384	3	Screw-Timer Hinge & Ground Wire
32	13881	1	Hinge Bracket
33	14087	3	Insulator
34	15314	1	Switch
35	10896	1	Switch,1RPM
36	11413	2	Screw-Switch Mounting
37	14007	1	Decal-Time of Day
39	13902	1	Harness-Not Shown
40	12681	2	Wire Connector-Not Shown
41	15354-01	1	Ground Wire-Not Shown
42	17870	1	Label,Indicator
43	15465	1	Label,Caution

Section 6.7.1 Remote Meter Delayed Regeneration Mechanical Timer Assembly

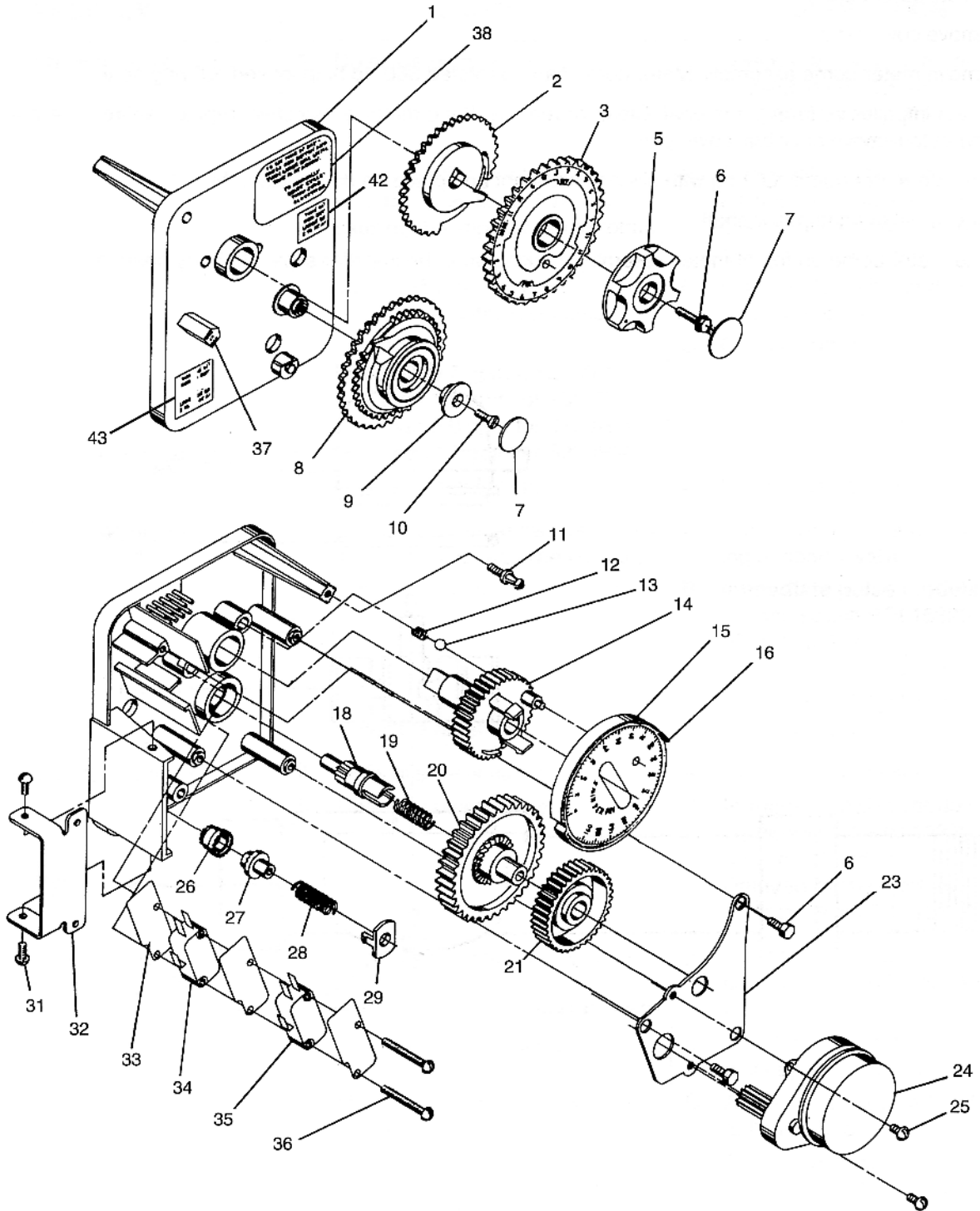

Section 6.7.1 Remote Meter Delayed Regeneration Mechanical Timer Assembly

DELAYED REGENERATION TIMER ASSEMBLY

ITEM NO.	PART NO.	QUANTITY	DESCRIPTION
1	13870-01	1	Timer Housing Assembly
2	13802	1	Cycle Actuator Gear
3	19205	1	24 Hour Gear Assembly
5	13886-01	1	Knob
6	13296	4	Screw-Timer Knob & Motor Plate Mtg.
7	11999	2	Button Decal
8	60405	1	Program Wheel Assembly,Specify Gallons
9	13806	1	Program Wheel Retainer
10	13748	1	Screw-Program Wheel Mtg.
11	14265	1	Spring Cup
12	15424	1	Spring-Detent
13	15066	1	Ball-1/4in. dia.
14	13911	1	Main Drive Gear
15	19210	1	Program Wheel Assembly
16	15493	21	Roll Pin
17			Not Assigned
18	13018	1	Idler Shaft
19	13312	1	Spring-Idler
20	13017	1	Idler Gear
21	13164	1	Drive Gear
23	13887	1	Motor Mounting Plate
24	13944	1	Motor-110V.,60Hz
	14104		Motor-24V.,60Hz
25	13278	2	Screw-Motor Mounting
26	13830	1	Drive Pinion-Program Wheel
27	13831	1	Clutch-Drive Pinion
28	14276	1	Spring
29	14253	1	Spring Retainer
30			Not Assigned
31	11384	3	Screw-timer Hinge & Ground Wire
32	13881	1	Hinge Bracket
33	14087	3	Insulator
34	10896	1	Switch
35	15320	1	Switch
36	11413	2	Screw-Switch Mounting
37	14007	1	Decal-Time of Day
38	16118	1	Decal-Instructions
39	13902	1	Harness-Not Shown
40	12681	2	Wire Connector-Not Shown
41	15354-01	1	Ground Wire-Not Shown
42	17870	1	Label,Indicator
43	15465	1	Label Caution

Section 6.8 Repair Kits

- #61530 – 2900S Upper Drive Seal & Spacer Kit
- #60121 – 2900 Upper Drive Seal & Spacer Kit
- #60128 – 2900 and 2900S Lower Drive Seal & Spacer Kit
- #60090-HF – 2900 Upper Drive Piston Assy.
- #61540 – 2900S Upper Drive Piston Assy.
- #60103 – 2900 Lower Drive Piston Assy. for Hard Water Bypass
- #61550 – 2900S Lower Drive Piston Assy. for Hard Water Bypass
- #60104 – 2900 Lower Drive Piston Assy. for No Hard Water Bypass
- #61555 – 2900S Lower Drive Piston Assy. for No Hard Water Bypass

See Section 10.2 for seal & spacer stuffer and puller part numbers.

Section 7. Recommended Start Up Procedure

7.1 Softener Start-Up

NOTE: *It is important to follow the startup instructions as improper start up may result in unsatisfactory softener operation or possibly damage the softener. Also on Systemax & ET units, confirm programming is as required. The programming when the unit left the factory is shown on the programming sheets in the ET or Systemax manual.*

1. Check all system piping ensuring that it is correct and all connections are complete, (see installation drawing fig. 4.1) and ensure the drain line has an air gap. Ensure that all of the manual isolation and bypass valves are closed prior to start up. Check all electrical connections and ensure that they are correct and complete (fig 4.8 or 4.9).
2. With the brine tank empty, add clean water (approx. 3.5 US gallons per cubic foot of resin Section 5.2.3) to the brine tank ensuring the water level is at least 2" above the grid plate. Add at least 15 lbs of salt for each cubic foot of resin to the brine tank and allow the brine tank to sit for a couple of hours to make a good brine solution. The salt level should be kept above the level of the water.
3. Plug in the control valve, and manually advance the valve out of the home position. (for ET & Systemax, see their respective manuals.) On all systems except system 7, this is done by the timer on the valve. (On system 7 units, the regeneration is initiated by the remote meter which electrically starts the appropriate valve timer) .This is done by removing the dust cover, and swinging the cycle timer open, in order to expose the program wheel located inside, (mechanical timers only) The meter cable may have to be temporarily disconnected. Turn the program wheel out of the home position, until the home switch comes out of the notch in the program wheel. Once the softener is in the backwash position, where the position switch rides up on to the first set of pins, (refer to section 8 for position confirmation), unplug the softener.
4. **Slowly** partially open the inlet isolation valve, and allow the softener to **slowly** fill with water. When the tank is full, water begins to run out through the drain. ***If the unit is filled too quickly, the media could be blown out, as well as possible damage the unit.*** When full, close the inlet valve.
5. Allow the unit to stand for 1-2 hours once the tank is full to saturate the media bed.
6. Plug the unit back into the power supply, and slowly open the inlet isolation valve all of the way, and allow the unit to automatically complete its regeneration cycle. During the backwash cycle, constantly check the drain water for resin to ensure nothing other than fines are being backwashed out. During the brine draw cycle, ensure the unit is drawing brine out of the brine tank. The brine should be drawn out in 15 to 30 minutes depending upon injector size and line pressure. Also check the brine tank refill cycle to ensure the water level returns to above the grid plate and there is no water flowing to the brine tank once the regeneration cycle is complete. Ensure that an adequate supply of salt is available, and that enough salt is situated in the brine tank. For example, if an FAF 120 softener was to be regenerated at 10 lbs/ft³, this equates into 40 lbs of salt required for one regeneration cycle. Thus at least 40 lbs is required in the brine tank for a single regeneration of this softener. It is recommended that the salt be above the water level. If the meter cable was disconnected, ensure it is reconnected.
7. Once the start-up is complete, the valve control system must be configured. (Note: if the system was purchased as a complete system, normally all the regeneration cycle times have been factory set. The only item(s) that have to be set would be the gallonage (for meter initiated units.) To configure a calendar clock or meter initiated softener, please refer to section 9. To configure either the ET Digital Timer, or the Systemax 2000 Controller, please refer to their service manuals.
8. Upon completion of the steps above, the softener outlet isolation valves are **slowly** opened, and the bypass valve can then be closed. The softener is now ready for normal service operation.. It is recommended that both the raw water and treated water be tested to confirm the unit is working properly.

Section 8. Softener Operation 2900 Valve

8.1 Operating Conditions

For correct operation of the softener system, the minimum water pressure required is 30 psig, (206 kPa), in order for valve to operate effectively.

Caution: Water Pressure is not to exceed 100 psig, (690 kPa), water temperature is not to exceed 100 °F, (38 °C), and the unit can not be subjected to freezing conditions without taking special precautions.

The manual bypass valve, (by others), must always be closed and the manual inlet and outlet isolation valves, (by others), open except during maintenance of the equipment.

8.2 Cycle Operation

The current position of the control valve can be confirmed by opening the control valve cover, and looking at the cycle cam position. Each cycle is completed at specific locations during the cam's rotation.

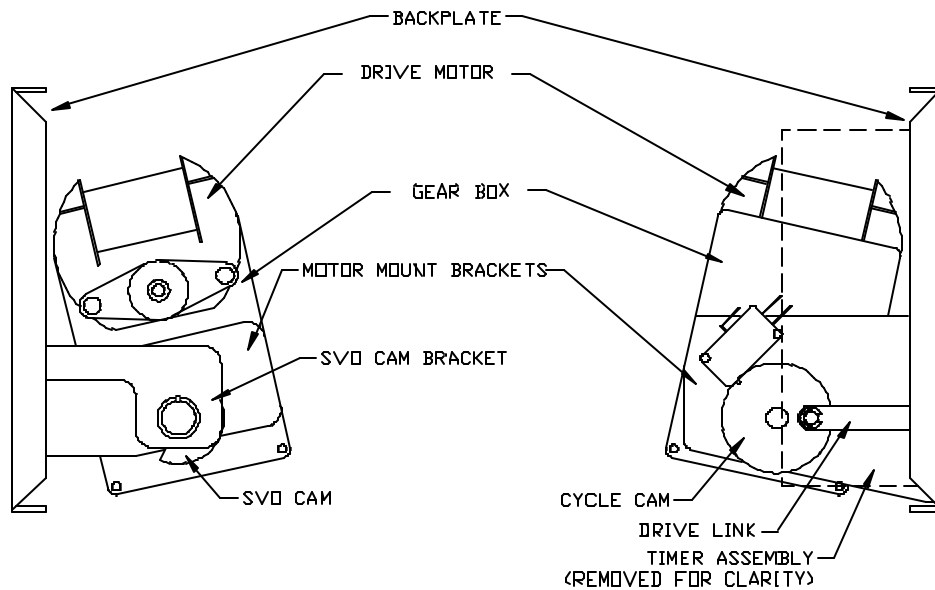

Fig. 8.1A Top Powerhead Schematic
(Powerhead shown with Standard Backplate, (Environmental Powerhead also Available))

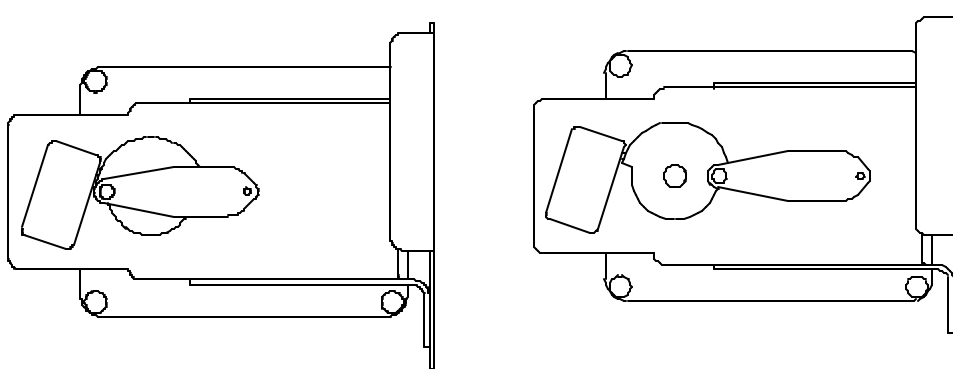

Fig. 8.1B Lower Powerhead Schematic
Left Powerhead Service Position Shown Right Powerhead Regeneration / Standby Position Shown

Position 1. Service

During service, water is directed into the top of the tank by the control valve and flows downward through the softener media, into the distribution, and out to service. As the water flows through the softener media, the hardness (calcium and magnesium) dissolved in the water is ionically exchanged with either sodium or potassium present in the softening resin. During service, the drive gear holds the drive link completely horizontal, with the piston withdrawn to its maximum length.

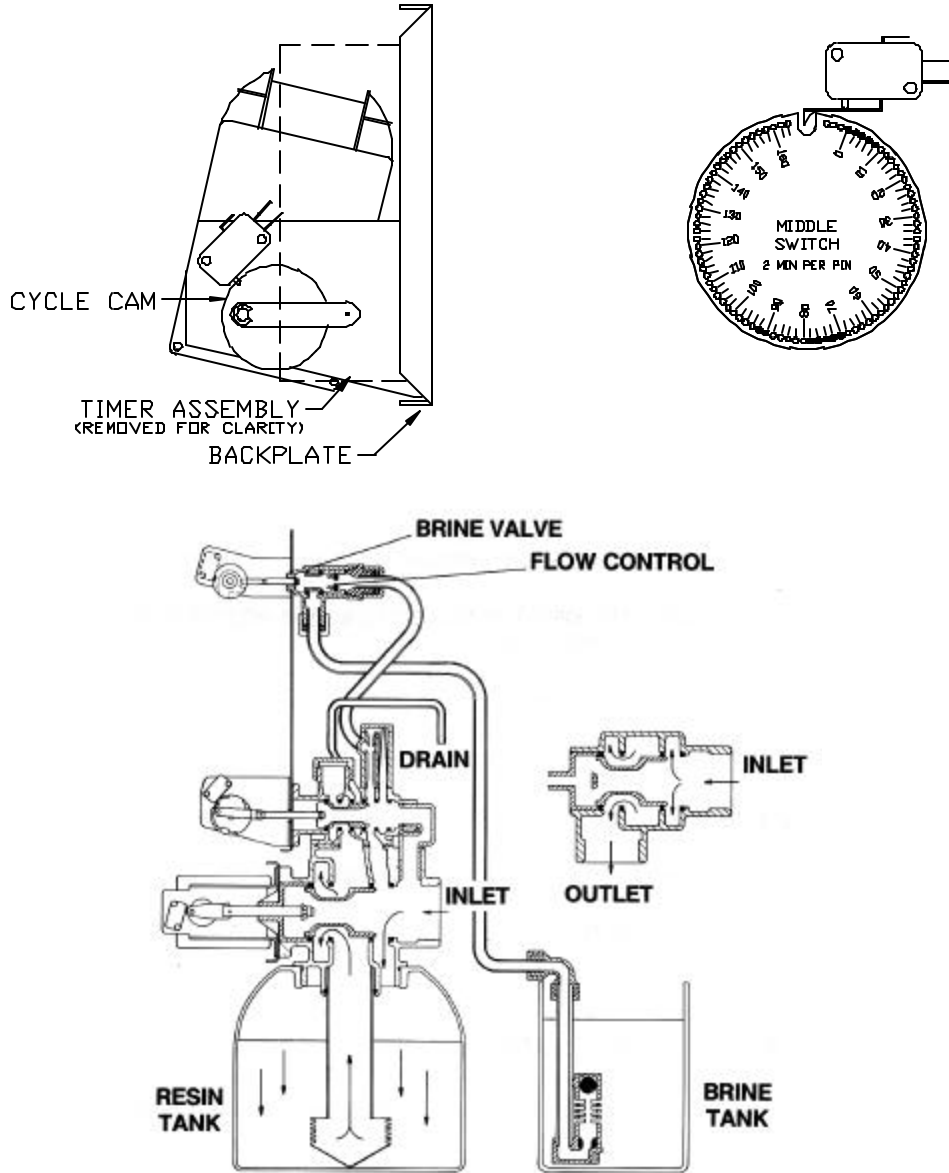

Fig. 8.2 Drive Motor Service Position , Program Wheel Location and Flow During Service

As the duration of the service run increases, the softening resin slowly depletes, losing its ion exchange capacity, until the softening resin can no longer remove the hardness (calcium and magnesium). It is at this time that regeneration of the softener is required, in order to replenish the bed's softening capacity. During regeneration the hardness (calcium and magnesium) that accumulated during the previous service run are replaced on the resin by sodium or potassium. A brine solution rinsed down through the bed is the source of the replenishing sodium or potassium.

Position 2. Backwash

The regeneration procedure is performed automatically by the softener after the cycle controller has started. Each regeneration cycle consists of four steps; backwash, brine draw/slow rinse, fast rinse, and refill.

During backwash, water is directed upwards through the filter and out to drain. This loosens the softener bed, allowing the brine solution to rinse through the resin more easily during the next cycle. The backwash cycle has been factory preset to take place for 10 minutes.

The drive gear holds the drive link completely horizontal, 180° from the service position, with the piston rod fully inserted into the valve body.

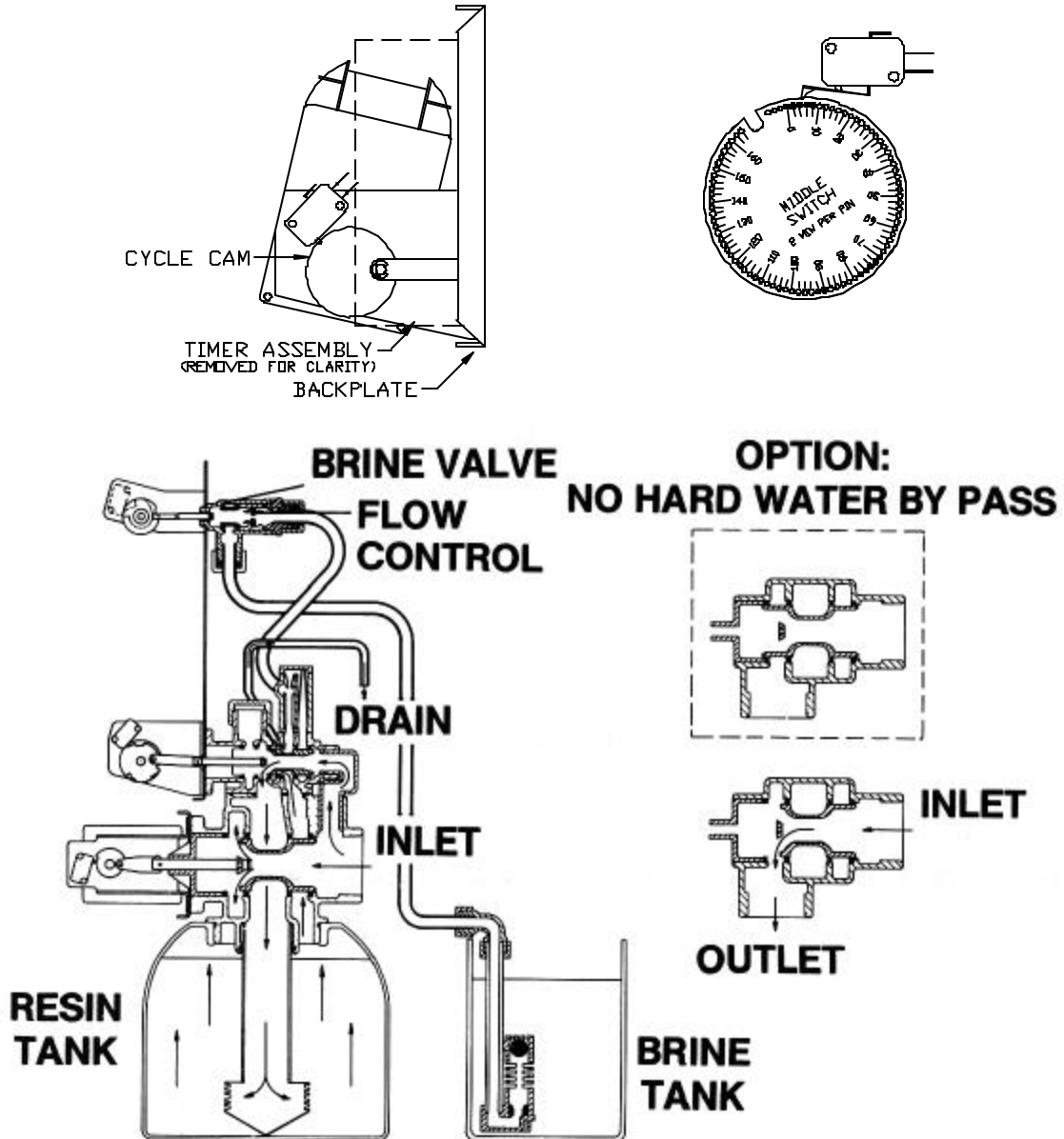

Fig. 8.3 Drive Motor Position , Program Wheel Location and Flow During Backwash

Position 3. Brine Draw

During the brine draw position, water flows through the injector, drawing in the brine solution. This solution then flows down through the bed, and out the drain. The brine draw cycle ends when the brine tank is empty, and the air check in the brine tank closes, stopping the flow of concentrated brine. Water continues to flow through the injector, and down through the bed, but no brine is drawn in. This is referred to as the slow rinse cycle.

When in the brine draw/slow rinse position, the drive link is rotated approximately 40° from the backwash position, until the drive gear stops with the drive link connection at the bottom of the drive gear, with the drive link at approximately 40° angle from the horizontal.

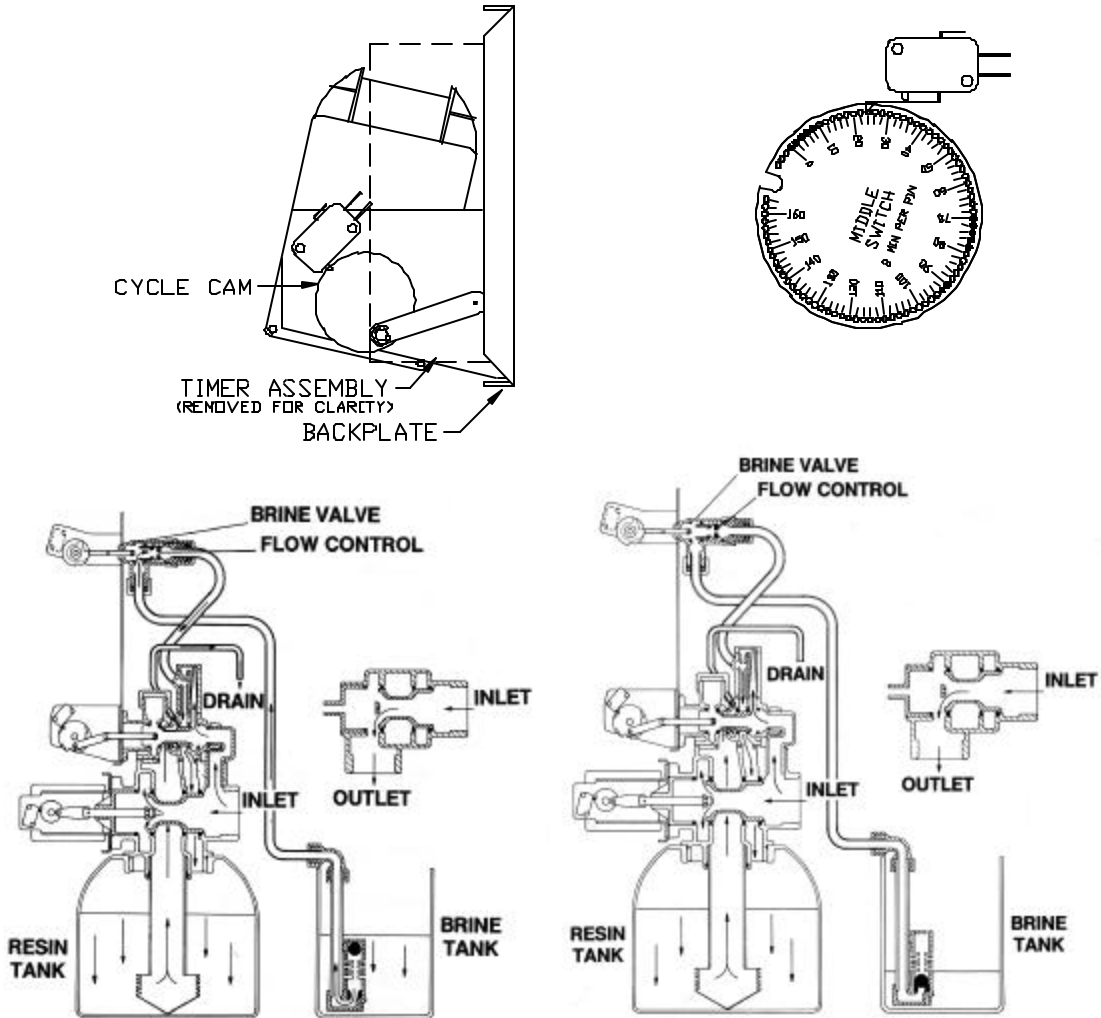

Fig. 8.4 Drive Motor ,Program Wheel Location and Flow During Brine Draw/Slow Rinse

Position 4. Rinse

During rinse, water is directed downwards through the softener and out to drain. This reconsolidates the softener bed and rinses any remaining brine in the softening bed to drain.

When in the rinse position, the drive link is rotated another 5° from the settle position, until the drive gear stops with the drive link connection at the bottom of the drive gear, with the drive link at a 45° angle from the horizontal.

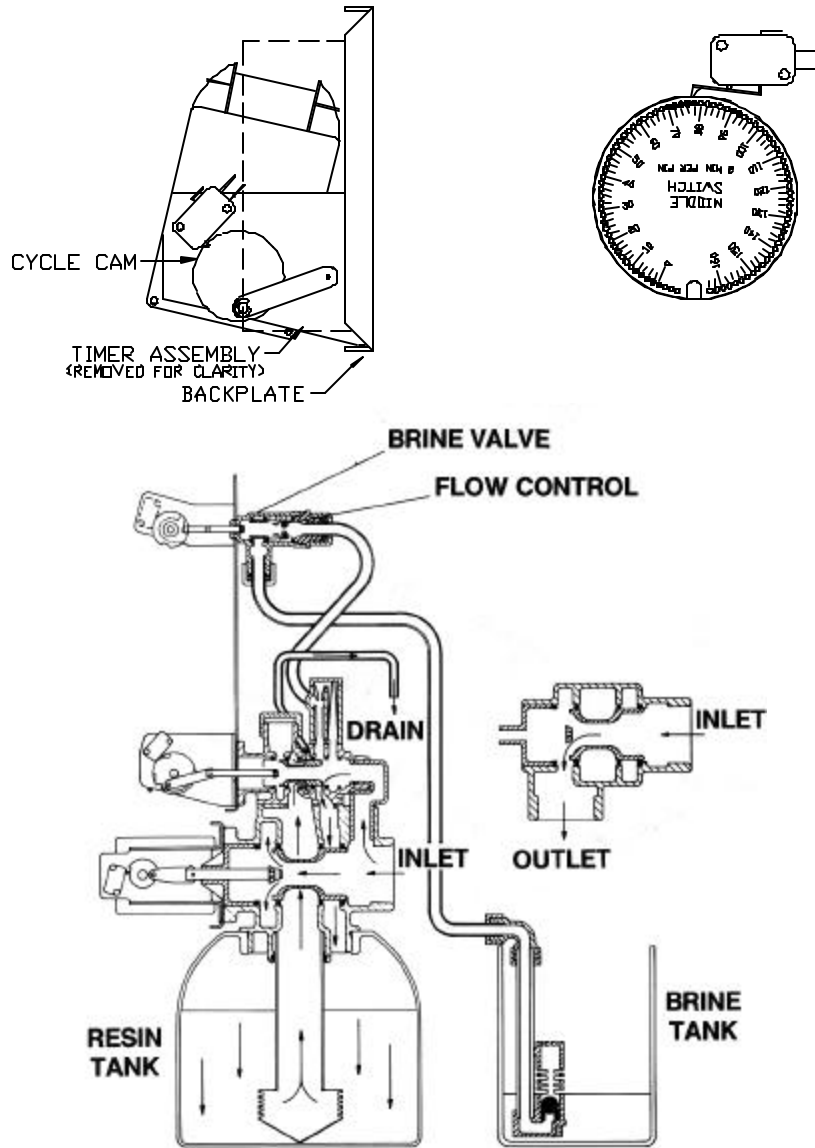

Fig. 8.5 Drive Motor Position , Program Wheel Location and Flow During Rinse

Position 5. Brine Tank Refill

Upon the fast rinse cycle ending, the softener advances into what is essentially service, with the exception that a portion of the softened water is diverted backwards through the injector, and into the brine tank. This is known as the brine tank refill cycle. The flow into the brine tank is controlled by a flow control orifice, and is timed in order to measure a calculated volume of water into the brine tank. The brine tank refill position is very similar to the service position, but the drive link stops just short of the horizontal. To confirm the refill cycle is occurring, simply watch the tubing running from the softener to the brine tank, and watch the brine tank to ensure that the water level is rising. The water should continue to flow to the brine tank until the microswitch is depressed by the last two pins on the cycle timer wheel.

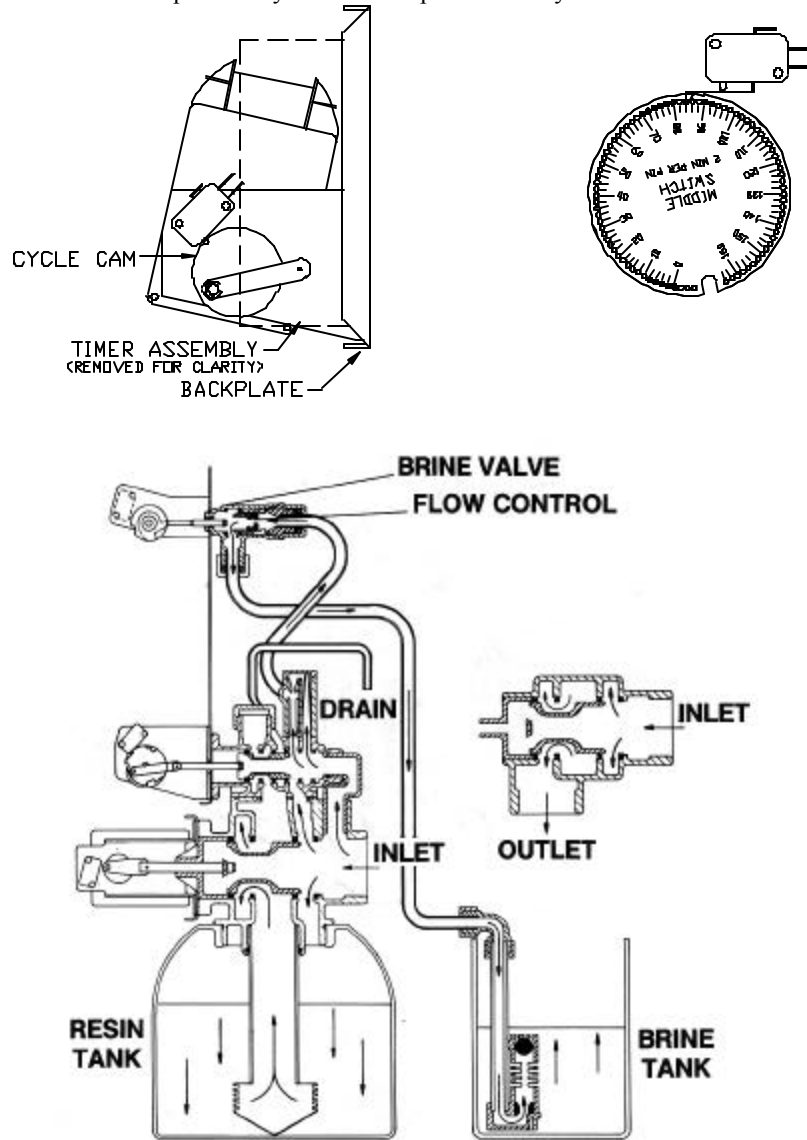

Fig. 8.6 Drive Motor Position , Program Wheel Location and Flow During Refill.

Section 9. Softener Control

The standard softener controller is a mechanical type controller, which automatically initiates the backwash sequence by one of two methods: calendar clock or volumetric meter.

All systems can be manually initiated by simply moving the manual regeneration knob clockwise. Only a slight turn is required to start the unit into regeneration. Remote meter initiated units should be manually initiated ONLY from the remote meter, which is again started by a slight clockwise movement on the remote meter timer knob.

Other control systems are available, such as the ET digital timer, which can replace the standard mechanical controller; and the Systemax 2000 Digital Controller, which looks after the operation of up to three, (3), separate units; including giving visual indication of flowrates, time, and allowing operator control of the method of initiation. *For information on configuring either the ET digital timer or the System Max, please consult their service manuals.*

For a description of the various systems, see section 1.

9.1 Calendar Clock

With calendar clock initiation, a 12-day repeating timer automatically initiates the regeneration sequence after a preset number of days during the 12-day cycle. The regeneration sequence is factory preset to occur at 2:00 AM on the day that the clock initiates regeneration. Once initiated, the cycle timer operates the control valve, advancing the valve into each position, and holding it there for a specific length of time. The interval between regenerations can be adjusted to suit each application, depending on the raw water quality. This time interval is adjustable, with a minimum regeneration sequence interval of one regeneration per day.

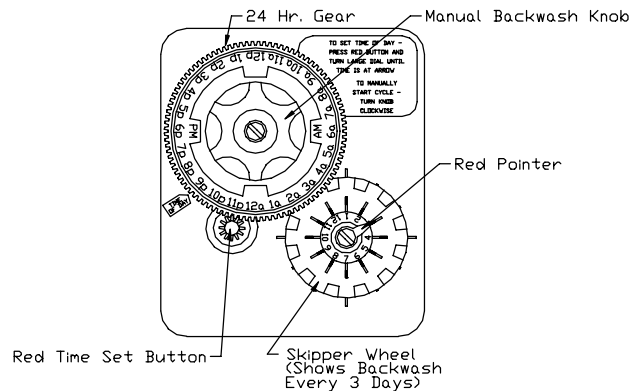

Figure 9.1 Calendar Clock Timer

Setting the time of day:

- Press and hold the red button in to disengage the drive gear.
- Turn the large gear until the actual time of day is opposite the time of day pointer.
- Release the red button to again engage the drive gear.

Frequency of regeneration:

To set the frequency of regeneration, simply pull out the metal tabs on the skipper wheel on the days that you wish the filter to regenerate. For example, every 3rd tab has been extended in the illustration above, indicating that regeneration of that filter will take place every three, (3), days.

9.2 Volumetric Meter

The second method of regeneration initiation is by a volumetric meter, which counts the volume of water as it passes through the filter during service. The meter is attached to a Fleck model 3210 control timer, by a rotating cable. The control timer has an adjustable volume dial on it, where the volume of water to pass through the meter between regenerations can be set. As the water flows through the flowmeter, the cable rotates, slowly moving the volume dial on the timer towards zero. On all standard single units, once the meter reaches zero, the start signal will be delayed until the preset time. (This is why on single units a reserve capacity needs to be calculated into the meter setting.) On all standard duplex units, once the meter reaches zero, it immediately signals the cycle timer to begin the regeneration sequence (provided that the other unit is not already in regeneration.). Once signalled, the cycle timer takes over for the duration of the regeneration cycle, controlling the regeneration sequence, just as in the calendar clock control method.

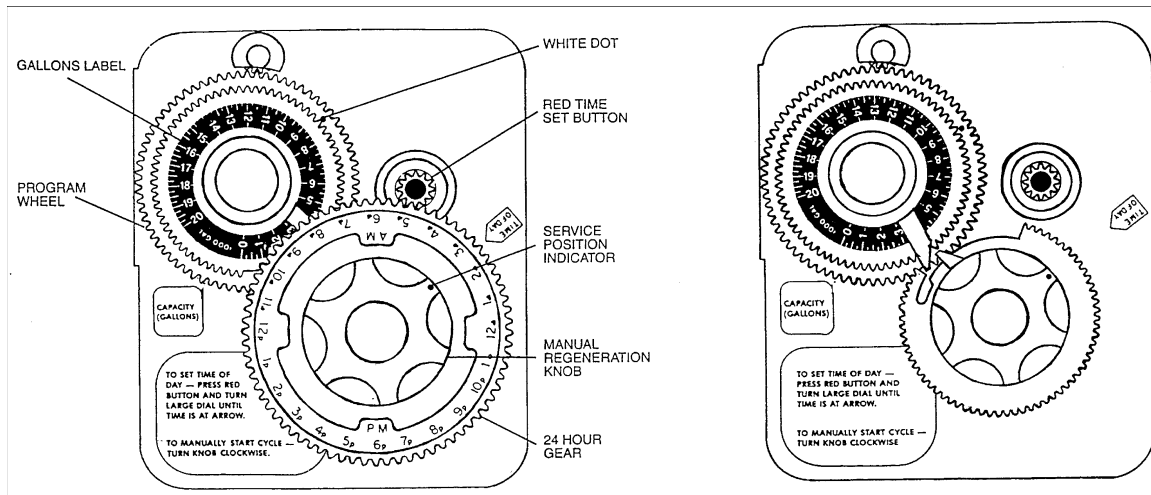

Fig. 9.2A Delayed Meter Timer

Fig. 9.2B Immediate Meter Timer

Meter Setting Procedure

System 4

- Take the number of cubic feet of resin in the tank and multiply by 27,000 grains per cubic foot (for a 10 lbs salt setting).
- Divide this number by the (compensated) grains of hardness in the water. This gives you the total number of gallons the softener can treat before regeneration is required. REMEMBER that 1 part of iron is equal to 4 grains of hardness and 1 part of manganese is equal to 8 parts of hardness. For commercial units, the combined ppm maximum for iron + 2x manganese is ONE.
- Since system 4 is delayed regeneration, a reserve (typically one-day) must be built into the meter setting.
- Typically for a three-day sizing, the reserve is 1/3 of the bed so take the total number of gallons and multiply by 0.67. This is what you set the meter for.
- For a two day sized unit, take the total number of gallons and divide by two. This is what you set the meter for.

System 5 or 7

- Take the number of cubic feet of resin in ONE tank and multiply by 27,000 grains per cubic foot.
- Divide this number by the (compensated) grains of hardness in the water. This gives you the total number of gallons the softener can treat before regeneration is required. REMEMBER that 1 part of iron is equal to 4 grains of hardness and 1 part of manganese is equal to 8 parts of hardness. For commercial units, the combined ppm maximum for iron + 2x manganese is ONE.
- Since system 5 & 7 is immediate regeneration, a reserve is not normally required.

System 6

- Take the number of cubic feet of resin in BOTH tanks and multiply by 27,000 grains per cubic foot.
- Divide this number by the (compensated) grains of hardness in the water. This gives you the total number of gallons the softener can treat before regeneration is required. REMEMBER that 1 part of iron is equal to 4 grains of hardness and 1 part of manganese is equal to 8 parts of hardness. For commercial units, the combined ppm maximum for iron + 2x manganese is ONE.
- Since system 6 is immediate regeneration, a is not normally required, but due to the fact that typically you get more water through one unit than the other, you may want to adjust the gallonage setting down to compensate for this factor.

9.3 Regeneration Cycle Timer (mechanical)

The cycle timer controls the operations of the valve during the regeneration sequence by incorporating a series of switches, which are opened and closed in a specific order to control the movement of the valve drive motor at certain times. The cycle timer rotating a program wheel accomplishes this. In this program wheel, there are holes spaced so that each hole takes two minutes to pass by. By inserting pins into these holes, and having the switches depressed by these pins as the program wheel rotates, the switches can be depressed in a specific order. The regeneration cycle timer is illustrated below. Note: you can tell if the motor is running by looking at the “viewport” located on the motor.

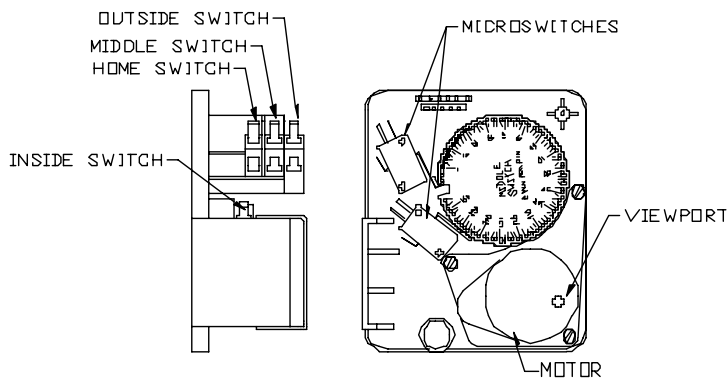

Figure 9.3 Regeneration Cycle Timer (Rear View)

The various typical standard softener control timer uses only the home, inside, and middle switches, with the outside switch being used only in specific custom applications. When certain switches in the control valve are closed simultaneously, the timer allows the valve drive motor to rotate, moving the piston to certain positions during the backwash sequence.

9.4 Regeneration Program

If the unit was purchased as a complete system, the regeneration cycle program on your valve has normally been factory pre-set. Typical cycle times are 10 minutes backwash, varying brine draw and slow rinse times (dependent upon the unit), 10 minutes rinse, and varying brine tank refill times (dependent upon the unit). It should be noted however, that these cycle times may be lengthened or shortened to suit local conditions. See Section 2.6 for standard cycle times.

The pins on the program wheel determine the length of each cycle. Each pin represents two minutes of cycle time. The length of each cycle is either the number of pins (for backwash or fast rinse) or the number of holes (for brine draw/slow rinse and brine tank refill). Please note that, when one set of pins is moved, it may affect the cycle time of other cycles unless other pins are also adjusted accordingly.

NOTE: Ensure pins for inside switch, (if required), do not extend far enough to cause interference with lower gear.

9.5 Changing the Regeneration Cycle Times

- To expose cycle program wheel, grasp the timer in upper left-hand corner and pull, releasing snap and swinging timer to the right.
- To change the regeneration cycle program, the program wheel must be removed. Grasp the program wheel and squeeze protruding lugs toward centre, lift program wheel off timer (switch arms may require movement to facilitate removal).
- Add or remove pins in the backwash or rinse cycles in order to lengthen or shorten the cycle times. See Section 2.6 for standard factory recommended pin settings.
- Make certain all electrical wires locate above snap retainer post when closing the timer assembly.

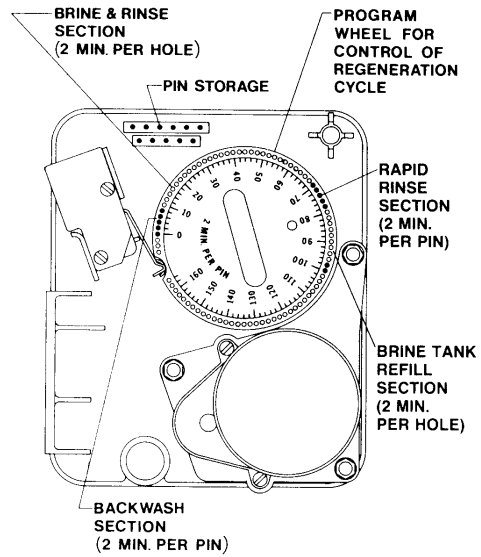

Fig. 9.5 Typical Preset Pin Settings

Section 10.1 Softener Trouble Shooting Guide

<u>PROBLEM</u>	<u>POSSIBLE CAUSE</u>	<u>REMEDY</u>
1. No water flowing to service.	A. Inlet and/or outlet isolation valves closed.	A. Open isolation valve(s).
	B. Unit unplugged during last regeneration.	B. Plug unit in, and return unit to service position.
2. Untreated water passing out to service.	A. By-Pass valve either partially open or not sealing.	A. Inspect bypass valve position and seal, replace or repair if necessary.
	B. Insufficient regeneration frequency and/or times and / or no salt in brine tank.	B. Increase regeneration frequency and/or backwash time and maintain salt level to above water level.
	C. Injector / screen plugged.	C. Clean injector / screen assembly.
	D. Insufficient water flowing into brine tank.	D. Check brine tank fill time and clean brine line flow control if plugged.
	E. Service flowrate exceeding maximum allowable rate.	E. Confirm service flowrate does not exceed recommended rate. Reduce if necessary.
	F. Broken or leaking distribution.	F. Inspect distribution, replace if necessary. Check O-ring between distribution riser tube and valve.
	G. Leak or crack in control valve seals. Particles partially jamming control valve.	G. Inspect seals, for damage and/or interference; replace if necessary.
	H. Flowrate through meter too low or meter not operating correctly.	H. Check meter with meter checker. Size meter to suit flowrate. Ensure meter operating correctly. Pull cable out of meter cover and rotate manually. Program wheel must move without binding and clutch must give positive "clicks" when program wheel strikes regeneration stop. If not working properly, replace timer.
	I. Have raw water bypass piston or no raw water bypass piston assembly failed.	I. Raw water bypass piston assemblies have white end plugs. No raw water bypass assemblies have black end plugs. Inspect piston & seals. Lubricate and/or replace internals if required.
	J. Fouled mineral bed.	J. Clean bed using resin cleaner. Replace bed if necessary. Most common fouling found on water containing iron and / or manganese.
K. Reserve capacity has been exceeded.	K. Check capacity and salt dosage requirements. Reset	

		program wheel to provide additional reserve.
3. Control valve fails to regenerate unit.	A. Loss of power to control valve.	A. Inspect power supply, ensure that control valve is powered and all connections are correct. Reset time of day (if required).
	B. Drive motor and/or timer assembly not receiving power.	B. Check continuity of wiring for shorts, breaks, etc.
	C. Drive gears and/or motor binding in gearbox.	C. Check motor and gearbox, ensure that they run smoothly.
	D. Control valve piston jammed in valve body due to foreign material in valve body.	D. Remove piston, clean piston and seal/spacer assembly with water, and lubricate. Replace seals & spacers if required.
	E. Broken or shorted microswitch.	E. Check microswitches for continuity replace damaged switch.
	F. Flowrate through meter too low	F. Size meter to suit flowrate.
4. Control valve continuously cycles unit.	A. Broken or shorted microswitch.	A. Check microswitches for continuity, replace damaged switch.
5. Water flows to drain continuously.	A. Inadequate sealing of seals due to foreign material trapped in valve body.	A. Remove Piston, inspect seals and spacers, flush with water.
	B. Damaged and/or broken seals or spacers	B. Replace damaged and or broken seals or spacers.
	C. Unit unplugged during last regeneration.	C. Plug unit in, and return unit to service position.
6. Media flowing out though service.	A. Broken distributor	A. Replace distribution
7. Loss of mineral through drain line	A. Air in system	A. Assure that system has proper air eliminator control. Check for dry well conditions.
	B. Improper sized drain line flow control	B. Check for proper drain rate. Note: if water temperature is very low, the drain line flow rate may have to be reduced.
8. Unit used too much salt.	A. Improper salt setting	A. Check salt usage and salt setting.
	B Excessive water in brine tank.	B. See problem #9
9. Excessive water in brine tank	A. Plugged drain line flow control	A. Clean flow control
	B. Plugged injector / screen	B. Clean injector / screen assembly.
	C. Foreign material in brine valve.	C. Replace brine valve seal and clean valve.
	D. Foreign material in brine line flow control	D. Clean brine line flow control.
10. Fails to draw brine properly.	A. Drain line flow control plugged	A. Clean drain line flow control
	B. Plugged injector / screen	B. Clean injector / screen assembly.

	C. Foreign material in brine valve.	C. Replace brine valve seal and clean valve.
	D. Foreign material in brine line flow control	D. Clean brine line flow control.
	E. Line pressure too low	E. Increase line pressure to 30 psi minimum.
	F. Internal control leak	F. Change seals, spacers and piston assembly.
	H. Service adapter did not cycle	H. Check drive motor and switches.
	I. Brine tank line too long or brine tank too far away.	I. Shorten brine line (recommended 5 feet maximum).
11. Loss of water pressure.	A. Scale or iron buildup in line to unit	A. Clean lines to unit.
	B. Inlet to valve plugged with foreign material.	B. Clean and inspect valve for damage. Repair as required.
	C. Iron buildup in unit.	C. Clean control valve and media bed.
12. Drain flows continuously.	A. Valve not programmed correctly.	A. Check timer program and position of control. If not positioning properly, check for faulty microswitches and / or adjustments.
	B. Foreign material in control.	B. Check brine valve and ensure it is operating properly. Remove powerhead and inspect bore. Remove any foreign material and check valve in various regeneration positions.
	C. Internal control leak.	C. Change seals, spacers and piston assembly.

(Treated Water Regeneration Only)

No supply/raw water available during service.	A. Inlet diaphragm valve installed incorrectly.	A. Inspect inlet piping, confirm proper locations for treated water regeneration diaphragm valves. Reinstall in correct locations if required. Check pressure source to the SVO. Ensure it is a continuous pressure supply equal to the max. pressure the filter is subjected to.
No treated water supply available during regeneration.	A. Treated Water Supply diaphragm valve installed incorrectly.	A. Inspect inlet piping, confirm proper locations for treated water regeneration diaphragm valves. Reinstall in correct locations if required. Ensure it is a continuous pressure supply equal to the max. pressure the filter is subjected to.
Treated water regeneration diaphragm valves not operating properly	A. Treated Water Supply diaphragm valve installed incorrectly.	A: Inspect tubing connections to diaphragm valves (see section 4). Ensure it is a continuous pressure

	supply equal to the max. pressure the filter is subjected to.
B. Diaphragm valves sticking	B. Inspect diaphragm valves internals and repair or replace as necessary.

Section 11.1 Seal and Spacer Replacement

1. Remove electrical plug from outlet, turn off water supply to valve and relieve water pressure.
2. Remove control box cover.
3. Disconnect the brine line, from the injector housing to the brine valve (if your unit has timed brine tank fill).
4. Remove the two cap screws that hold the back plate to the valve.
5. Grasp the back plate on both sides and slowly pull end plug and piston assembly out of the valve body, (see Fig. 1) and lay aside.

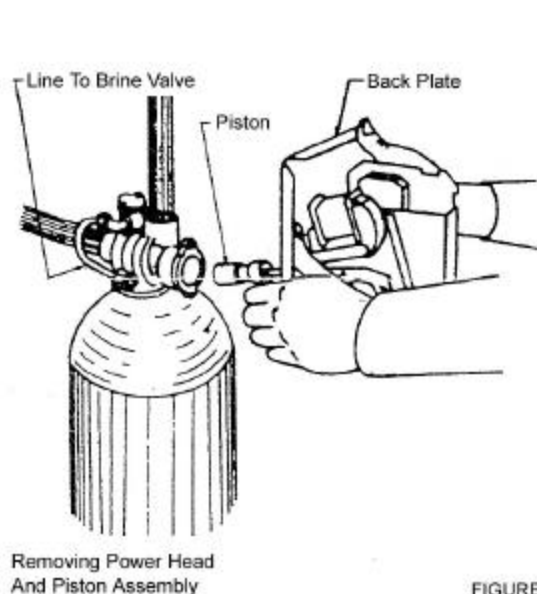

FIGURE 1

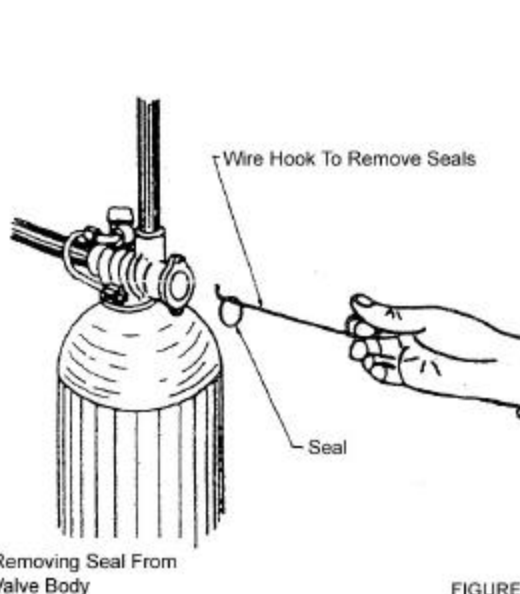

FIGURE 2

6. Remove the seal first using the wire hook with the finger loop (see Fig. 2)
7. The spacer tool (sue only for removing the spacers) has three retractable pins, retained by a rubber ring, at one end; they are retracted or pushed out by pulling or pushing the center button on the opposite end.
8. Insert the pin end of the spacer tool into the valve body with the pins retracted (button pulled back). Push the tool tight against the spacer and push the button in, (see Fig. 3). When the button is pushed in, the pins are pushed out to engage the ¼ dia. Holes in the spacer. Remove the tool from the valve body. The spacer will be on the end. Pull the center button back, the pins will be retracted and the spacer can be removed from the spacer tool.

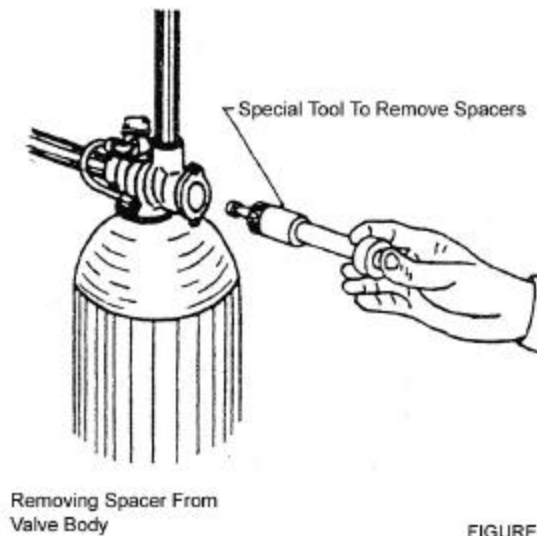

FIGURE 3

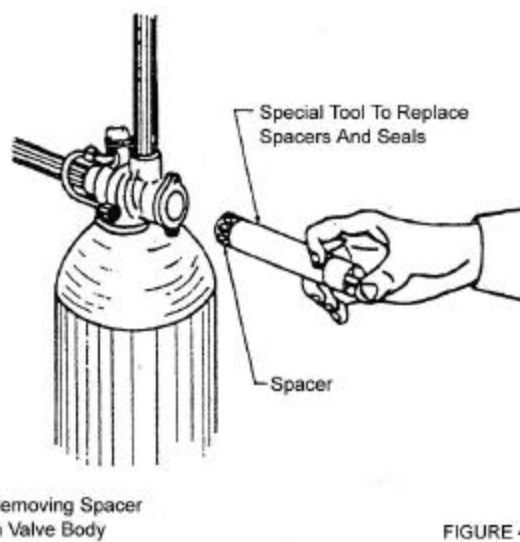
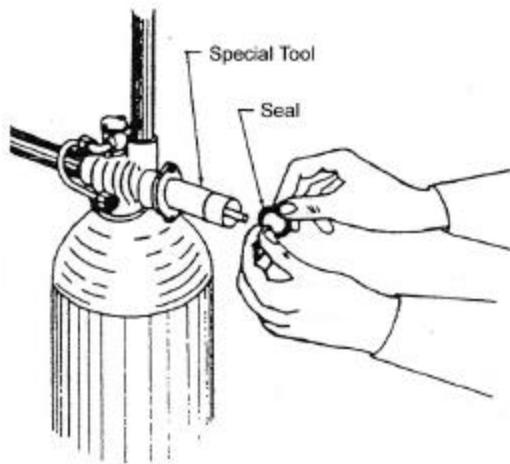

FIGURE 4

9. Alternately remove the remaining seals and spacers in accordance with steps No.6 and 8.
10. The last or end spacer does not have any holes for the pins of the spacer too to engage, therefore if the end spacer does not come out on the first try, try again using the wire hook with the finger loop.
11. To replace seals, spacers and end ring use special tool with the brass sleeve on one end. This is a double-purpose tool. (See Fig. 4.) The male end acts as a pilot to hold the spacers as they are pushed in—to the valve body and the brass female end is used to insert the seals into the valve body.
12. To restuff a valve body first take the end ring, (the plastic or brass ring without holes), then with your thumb press the button on the brass sleeve end, the large dia. Inner portion is now exposed. (See Fig. 4.) Place the end ring on this pilot with the lip on the end ring facing the tool, and push the tool into the valve body bore until it bottoms. While the tool is in the valve body take a seal and press it into the inside diameter of the exposed brass female end. (See Fig. 5.)
13. Remove the tool, turn it end for end and insert it into the valve body bore. While holding the large dia. Of the tool, slide it all the way into the valve body bore until it bottoms, then push the center button to push the seal out of the tool and leave it in place in the valve body. (See Fig. 5.)
14. Remove the tool from the valve body and push the center on the brass female end to expose the pilot on the opposite end. Place a spacer on this end and insert the spacer and tool into the valve.



Placing Seal in Brass Sleeve
Of Special Tool

FIGURE 5

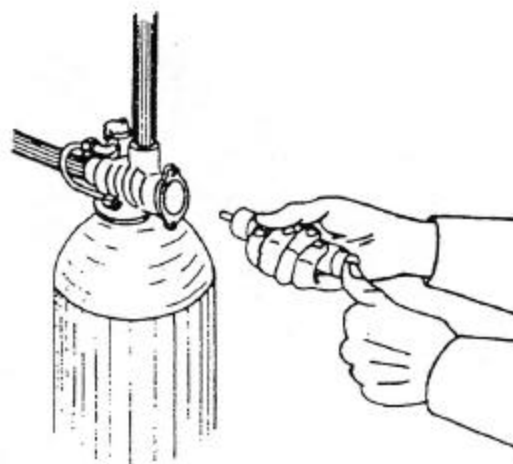

Removing Special Tool From Valve
Body After Inserting Seal

FIGURE 6

15. While the tool is still in the valve, press another seal into the inside diameter of the exposed brass sleeve end.
16. Remove the tool, turn it end for end, and insert it into the valve body bore.
17. Alternately repeat steps No. 13 and 14 until all seals and spacers have been pushed into the valve. (See valve cross section of your valve.)
18. Place silicone lubricant on the piston and inside the valve.
19. Hold the back plate with one hand and guide the piston into the valve body with the other hand, then grasp the back plate on both sides and slowly push the piston assembly and end plug assembly into the valve. (See Fig. 1.)
20. Replace the two cap screws to hold the back plate to the valve and tighten securely.
21. Connect the brine line from the injector housing to the brine valve, (if your unit has timed brine tank fill).
22. Set the time of day dial to the correct time.
23. Replace the electrical plug in the outlet.
24. Turn on water supply.
25. Cycle control and check for proper function.
26. Check by-pass valve.

Piston Assembly Replacement

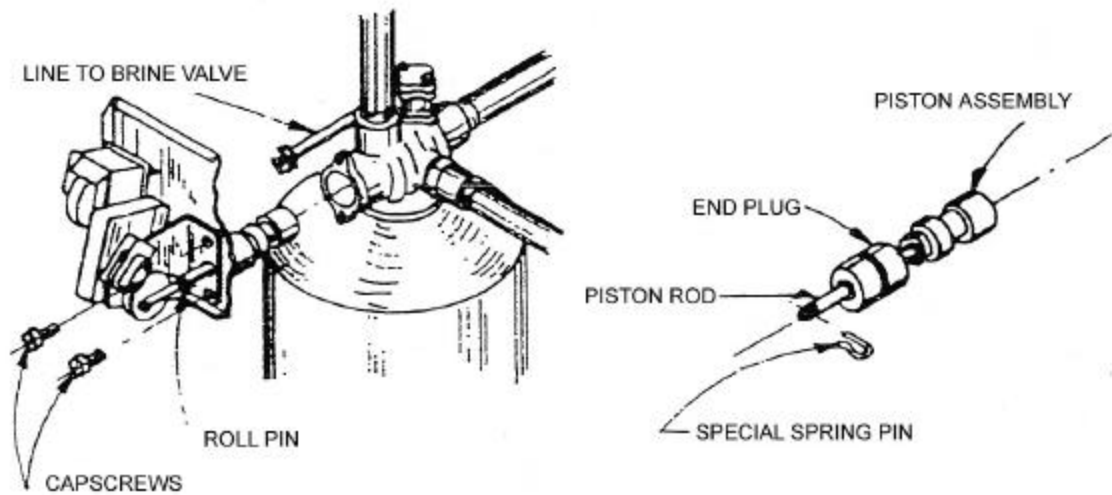

1. Turn off water supply to the valve and relieve water pressure.
2. Cycle the valve until the piston is in the service position (piston rod all the way out).
3. Remove electrical plug from outlet.
4. Remove two cap screws holding back plate to valve.
5. Disconnect brine line, from injector housing to brine valve, at the brine valve (if your unit has timed brine tank fill).
6. Grasp the back plate on both sides and slowly pull end plug and piston assembly out of the valve body.
7. Pull out the roll pin or special spring pin that connects the piston rod to the connecting link and remove the complete end plug and piston assembly.
8. Take the new piston assembly as furnished, pass through the back plate and motor support and fasten piston rod to the connecting link with special spring pin.
9. Inspect the inside of the valve to make sure that all seals and spacers are in place.
10. Spread or spray silicone lubricant on the piston and on the seals inside the valve body.
11. While holding the back plate on the side with one hand, start the piston into the valve by guiding it with the other hand. Then grasp the back plate on both sides and slowly push the piston and then the end plug into the valve.
12. Replace the two valve body cap screws and tighten.
13. Connect the brine line to the brine valve, if used.
14. Place electrical plug in outlet.
15. Set time of day.
16. Turn on water supply.
17. Cycle control and check for proper function.
18. Make sure that valve is in service position (piston rod all the way out).
19. Check by-pass valve.

	Seal & Spacer Stuffer Part Number	Seal & Spacer Puller Part Number
2750 Valve	11098	13061
2850 Valve	16516	17623
2900 Valve	12683	12682
3150 Valve	12683	12682
3900 Valve	12683	12683
9000 Valve	12763	13061
9500 Valve	16516	17623

* Other tools include: #12874 Seal Hook
#13644 Molex Pin Tool

PRESSURE VESSEL LIFTING, HANDLING & INSTALLATION INSTRUCTIONS



STRUCTURAL
PRESSURE VESSELS

Contents

	Page
Receiving	3
Basic Handling Rules	4
Approved Lifting Methods	8
Installing Pressure Vessel with Fiberglass Base .	10
Installing Pressure Vessel with I-Beam Base	12
Flange Cover Assembly and Torque Ratings	18
Side Flange Support Strength	20
UV Protection	21
Vacuum Protection Flex Connectors	22
Flexibility in Piping	23
Vertical Base Removal and Replacement	25
Install the New Base	27

RECEIVING

Pressure vessels from Structural North America are protected during shipment by custom-size cradle skids. All pressure vessels are placed horizontally on the skid.



A pressure vessel with an integral fiberglass base should be placed in a vertical upright position before removing its skid.

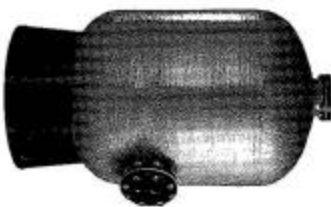

A pressure vessel with an I-Beam base to be attached, should remain in a horizontal position until ready to attach legs.

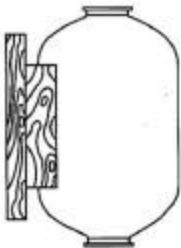
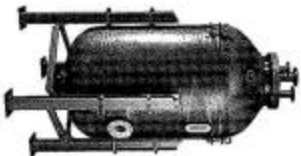

At the time of delivery, inspect both the inside and outside of the pressure vessel. If damage has occurred, notify the carrier immediately or prior to signing the acceptance form. Damage occurring during shipment is the responsibility of the carrier. Any damage claims must be pursued promptly by the receiving party with the delivering carrier.

BASIC HANDLING RULES

This guide is designed to help install pressure vessels properly. Improper handling or installation can result in damage or pressure vessel failure.



1. If pressure vessels are being stored prior to installation, leave them in their **protective shipping skid** until ready to install.

3. Never drop a pressure vessel or allow **hard impact or abrasion** of the pressure vessel from contact with walls, partitions, tools, or equipment.

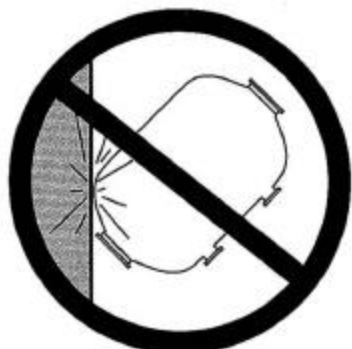

2. Never roll or slide a pressure vessel on its side.

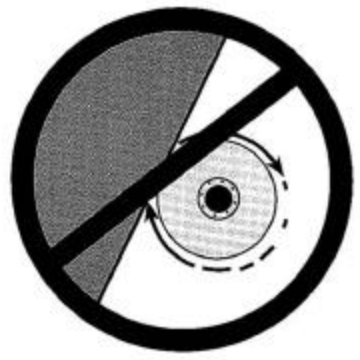

4. Lift the pressure vessel using a **crane or forklift** and the approved methods shown on pages 8 and 9.

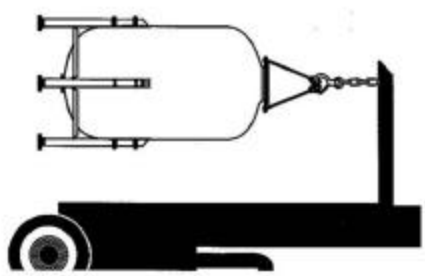

4

5

BASIC HANDLING RULES continued



5. Operators of hoist equipment must follow **proper rigging** procedures.



6. Avoid use of hooks or equipment on the **inside** of the pressure vessel.

7. Set rigging to lift from the **outside**, otherwise the lining could be damaged.

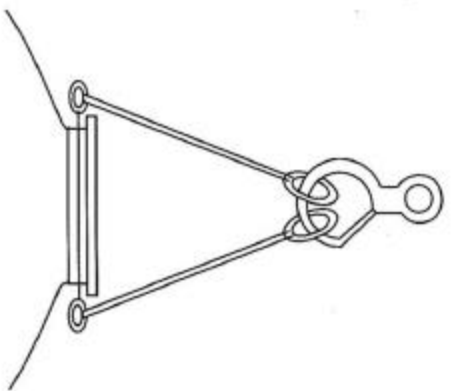

8. Never fasten cables or chains around pressure vessel. Use canvas or nylon straps to avoid damage to the flange area.



6

7

APPROVED LIFTING METHODS

By Flange

The empty pressure vessel is lifted by placing a user-supplied, webbed nylon reinforced sling, Penco, or rated steel cable around the top flange. Sling must be rated at minimum of 10,000 lbs. (4,500 kg).
CAUTION: Steel cable must have protective coating to prevent scratching of the flange's Teflon coating.

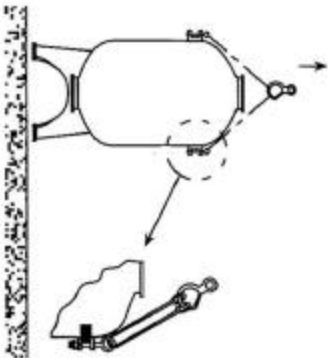
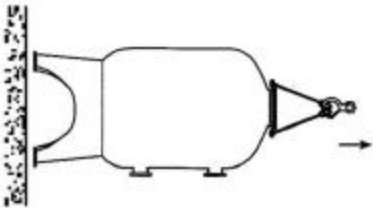

By Lifting Lugs

Bolt lifting eyes to the pressure vessel's integral lifting lugs (if specified) and attach a rated (10,000 lbs.; 4,500 kg) steel cable to the eyes.
CAUTION: Protect the flange's protective coating from being scraped by the cables.

By Lift Strap

Attach a 1/2" (12.7 mm) thick, user-supplied steel lift strap to the top flange, using at least two (2) holes per side. Then connect to a rated (10,000 lbs.; 4,500 kg min.) eyehook and cable.

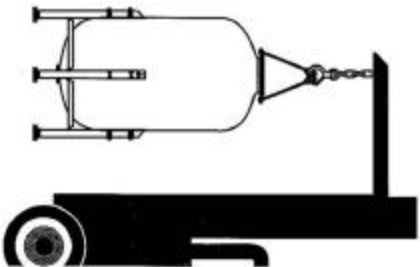
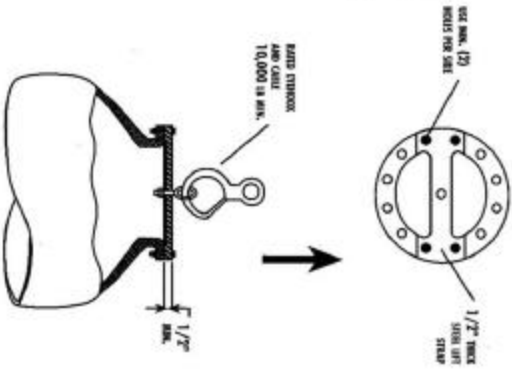

By Forklift

When unloading and installing a pressure vessel with I-Beam base, the pressure vessel may be lifted using a forklift unit.
CAUTION: Use only the approved sling rig methods; do not place chain or cable around or inside pressure vessel. Be sure forklift is designed to handle the pressure vessel's weight at the height the pressure vessel is to be lifted above the floor.

INSTALLING PRESSURE VESSEL WITH FIBERGLASS TRIPOD OR SKIRT BASE

To prevent breakage of the Fiberglass base, the following procedure is recommended for handling, unloading, and installing these pressure vessel types.



1. When delivered, the pressure vessel and skid may be in a horizontal position. The first step is to stand the whole assembly upright. All precaution described earlier should be observed to protect the pressure vessel from damage.

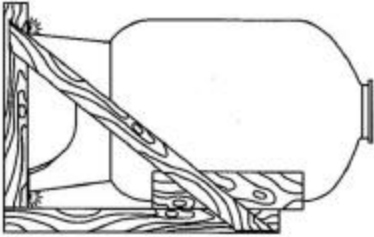

2. When the pressure vessel and skid are upright, remove the lag bolts which are holding the skid to the base of the pressure vessel.

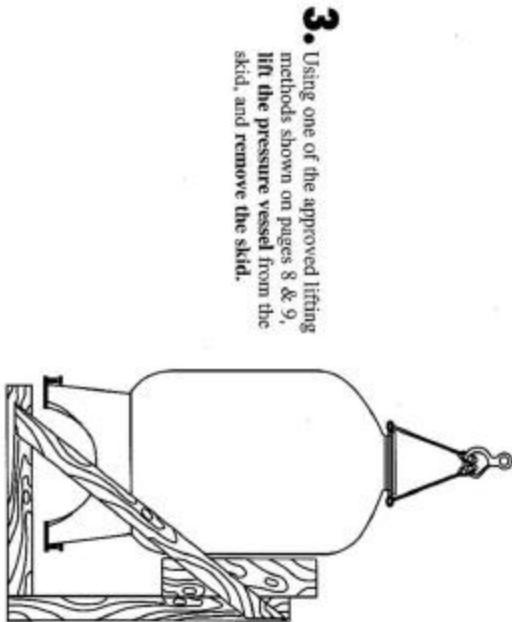

3. Using one of the approved lifting methods shown on pages 8 & 9, lift the pressure vessel from the skid, and remove the skid.

4. Lower the pressure vessel to the floor, level the pressure vessel, and anchor it with 3/8" lag bolts to floor.

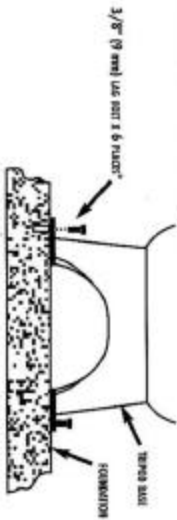

* FORS AND ASSOCIATES, INC. CONSULTING ENGINEERS, 10000 15TH AVENUE, DENVER, CO 80202

INSTALLING PRESSURE VESSEL WITH I-BEAM BASE

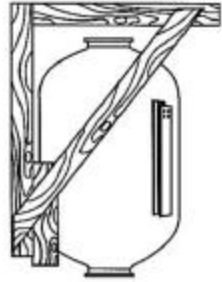

1. When delivered, the pressure vessel and skid will be in a horizontal position. Leave pressure vessel on skid and remove the four legs which were temporarily attached for shipment.

4. Install the 7-3/4" (197 mm) long cross brace brackets to the legs, with the slotted surface up.

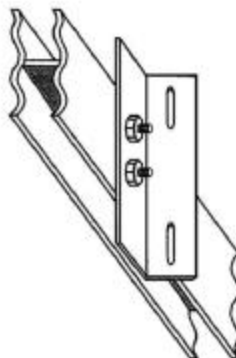

2. Install a pair of 2" (51 mm) long angle brackets to the bottom of each of the legs.

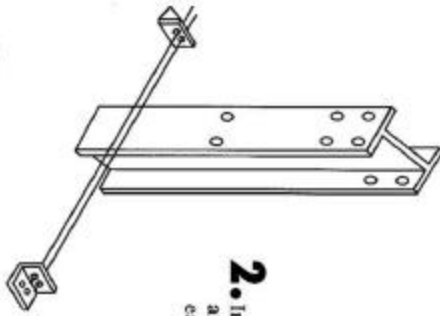

3. Attach a leg pad to the angle brackets on each leg.

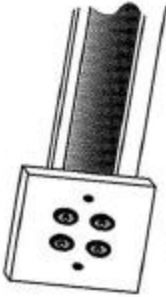

5. Lift the pressure vessel from the skid and into a full upright position. Keep the pressure vessel suspended until remaining hardware is attached and secured.

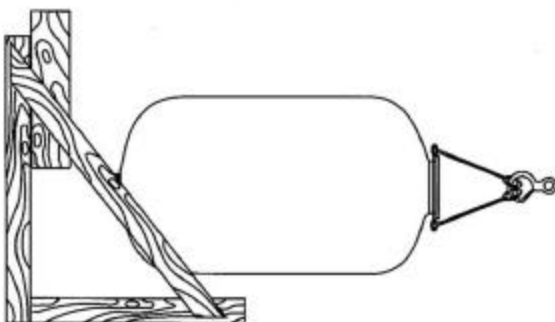

12

13

INSTALLING PRESSURE VESSEL WITH I-BEAM BASE continued

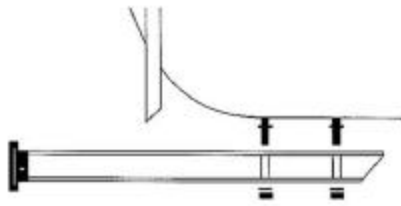

6. Attach the legs, inserting a spacer within the I-Beam web at each bolting point. See page 17 for details.

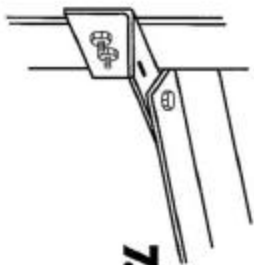

7. Attach the cross braces on all four sides.

8. Tighten all bolts, position pressure vessel over supporting surface and gently lower pressure vessel into place. (Refer to local code requirements.)

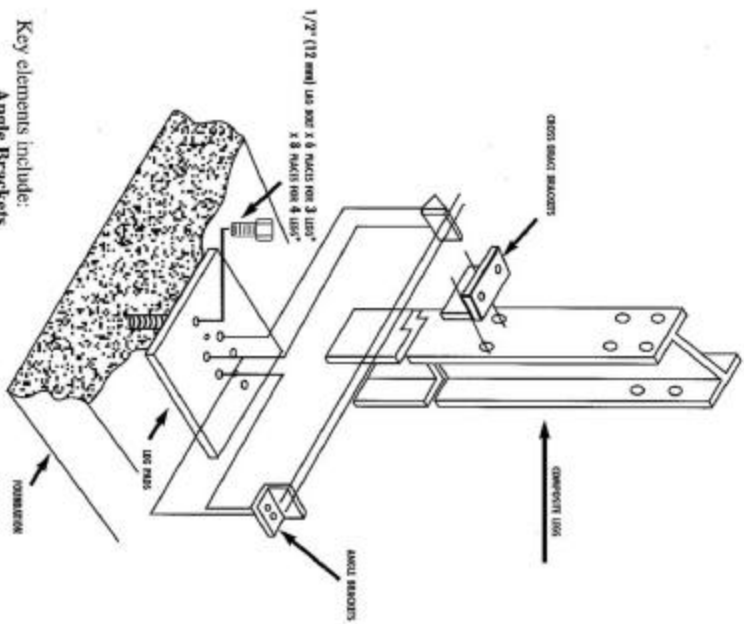

- Key elements include:
- Angle Brackets
 - Leg Pads
 - Cross Brace Brackets
 - Cross Braces
 - Composite Legs

* THIS AND ALL OTHERS SHOWN ARE FOR GENERAL INFORMATION ONLY. THE MANUFACTURER SHALL BE RESPONSIBLE FOR THE DESIGN AND CONSTRUCTION OF THE VESSEL.

INSTALLING PRESSURE VESSEL WITH I-BEAM BASE continued

9. Adjust the internal nuts to level the leg.

10. DO NOT raise or lower the pressure vessel by pivoting on the leg base. Permanent damage will result.

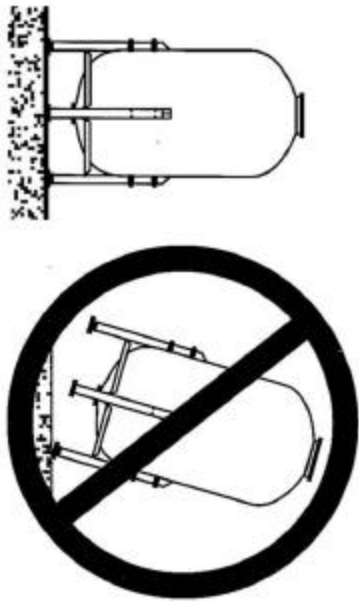

3.0 MM FOR 28", 30" AND 36" PA. PRESSURE VESSELS
 4.0 MM FOR 42", 48", AND 60" PA. PRESSURE VESSELS

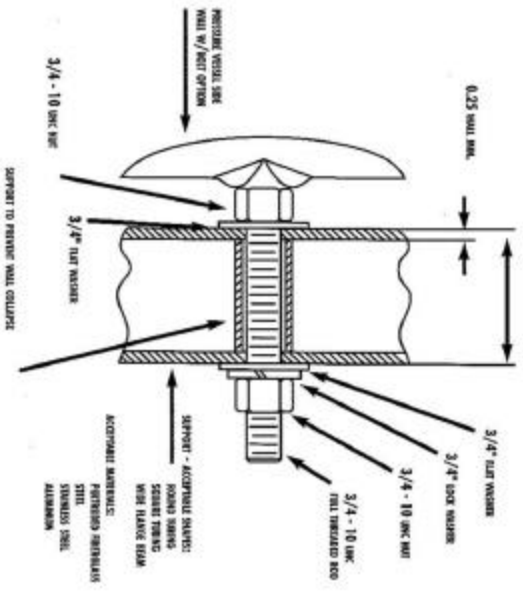

In connecting the I-Beam legs to the integral bolts on the pressure vessel, the hardware sequence is:

- Nut
- Flat Washer
- Leg with Spacer
- Flat Washer
- Lock Washer
- Nut

FLANGE COVER ASSEMBLY AND TORQUE RATINGS

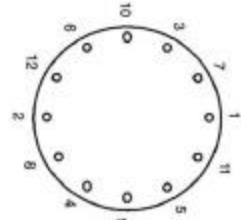

12-bolt Flange Cover (6", 152 mm Flange)
Tightening Sequence for 5/16" (7.9 mm)
Stainless Steel Bolts
Torque to 11 ft.-lbs. (15 NM)

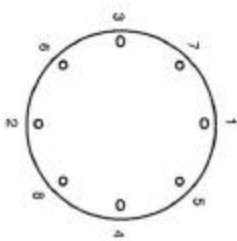

8-bolt Flange Cover (4-1/2", 114 mm Flange)
Tightening Sequence for 3/4" (19 mm)
Stainless Steel Bolts
Torque to 130 ft.-lbs. (176 NM)

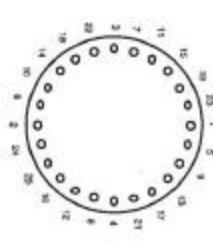

24-bolt Manway Flange Cover
24" (610 mm) Dia. Pressure Vessels
Tightening Sequence for 3/8" (9.5 mm)
Stainless Steel Bolts
Torque to 18 ft.-lbs. (24 NM)

For 24" Diameter Vessels

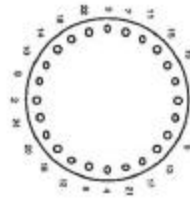

24-bolt Manway Flange Cover
Tightening Sequence for 1/2" (12.7 mm)
Stainless Steel Bolts
Torque to 45 ft.-lbs. (61 NM)



8-bolt, 4" (102 mm) ANSI Flange
Tightening Sequence for 5/8" (15.9 mm)
Stainless Steel Bolts
Torque to 90 ft.-lbs. (122 NM)

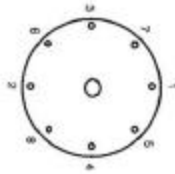

8-bolt, 6" (152 mm) ANSI Flange
Tightening Sequence for 3/4" (19 mm)
Stainless Steel Bolts
Torque to 130 ft.-lbs. (176 NM)

TORQUE CHART

5/16" (7.9 mm) s/s bolts = 11 ft. lbs. (15 NM)
3/8" (9.5 mm) s/s bolts = 18 ft. lbs. (24 NM)
1/2" (12.7 mm) s/s bolts = 45 ft. lbs. (61 NM)
5/8" (15.9 mm) s/s bolts = 90 ft. lbs. (122 NM)
3/4" (19 mm) s/s bolts = 130 ft. lbs. (176 NM)

SIDE FLANGE SUPPORT STRENGTH

Valves, piping and hardware all contribute to the weight loads put on side flanges.

Side Flanges are rated for a bending torque, M , maximum of 50 ft. lbs. This means that:

$$d \times F \text{ must be } \leq 50 \text{ ft. lbs.}$$

For $d = 1$ ft., $F_{max} = 50$ lbs.

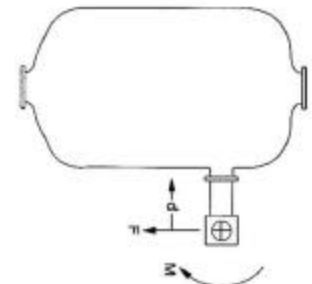

Where d = distance in feet from flange face to center of the load (such as a valve)
 F_{max} = maximum support load in pounds

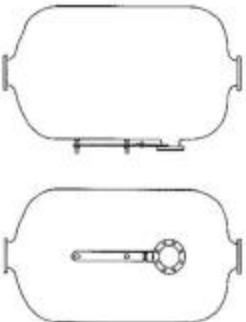

To support greater loads, a support kit, No. 12647, is available for upper side flanges only. With the support kit, the side flange is rated for a bending torque, M , of 300 ft. lbs.

Thus, for $d = 1$ ft.,
 $F_{max} = 300$ lbs.

Note: Lower side flanges not available when upper side flange support kit is used.

20

UV PROTECTION

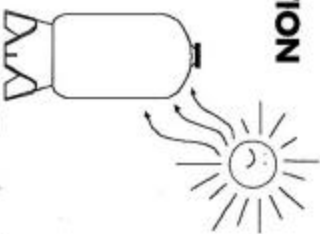

Painting a Composite Pressure Vessel for UV Protection

1. Wash the pressure vessel with detergent and water, using a scrub brush. Use the brush actively over the pressure vessel surface to remove oil and grime.
2. Rinse the pressure vessel several times with water to remove soap residue and let dry.
3. Using a clean rag wetted with acetone, rinse the pressure vessel thoroughly with the acetone. Make sure that the rag does not become gritty, and use as much acetone as is practical to perform a "wet rinse" over the pressure vessel surface. **NOTE:** Acetone is extremely flammable. Should not be inhaled. Requires use of gloves.
4. Spray paint or paint with a roller or brush.
5. A 100% interior/exterior acrylic latex enamel is preferred. The paint has a good adhesion and will not chalk. This is a one-step paint with water clean-up. The 100% acrylic latex enamel can be purchased at a paint store.
6. Coat the UV areas first, such as the top of the pressure vessel and the side, where sun rays directly hit the pressure vessel.
7. A light-colored, pigmented paint is preferred. White paint is best.

21

VACUUM PROTECTION FLEX CONNECTORS

The pressure vessel is rated for an internal negative pressure of 5" Hg (17 Pa) vacuum below atmospheric. If negative pressure could ever exceed 5" Hg (17 Pa), an adequate vacuum breaker must be installed between the pressure vessel inlet and any valves, as shown here.

System connections to the pressure vessel must accommodate vertical expansion between side, top, and bottom openings. Either flexibility in piping, as shown on pages 22 and 23, or flex connectors as shown here, are recommended.

Flex connectors and Vacuum Breakers are available from Structural North America. Please consult SNA accessory catalog. Contact Customer Service; Tel: 440-286-4116, Fax: 440-286-4351

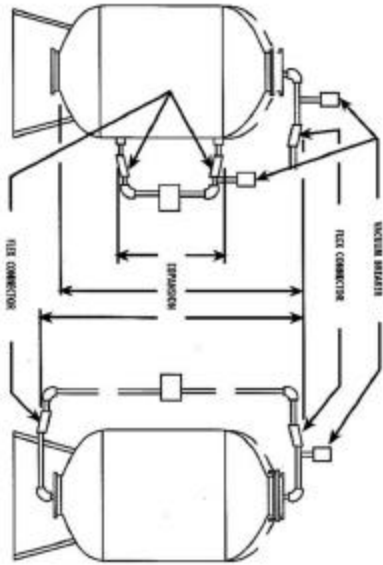

NOTICE

FLEXIBILITY IN PIPING

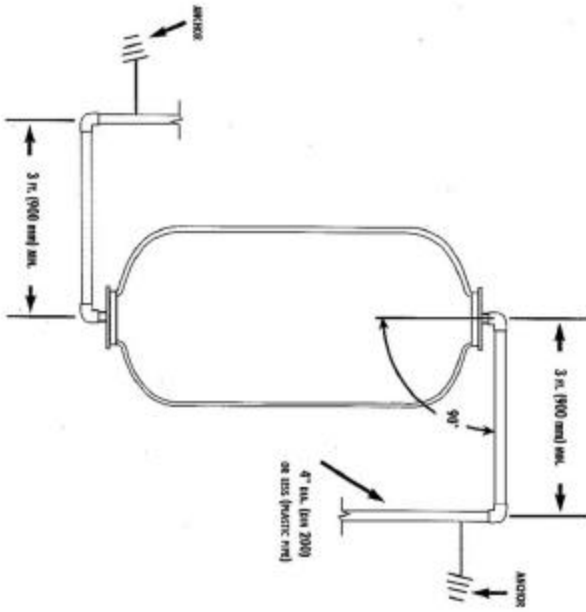

An effective alternative to flex connectors uses the inherent flexibility of right angle system design. By calculating the amount of cantilever overhang needed to absorb the torsional effect created by the pressure vessel's vertical movement, it is possible to build the needed flexibility right into the piping system. This can be done with both top/bottom and side flow piping setups.

FLEXIBILITY IN PIPING (continued)

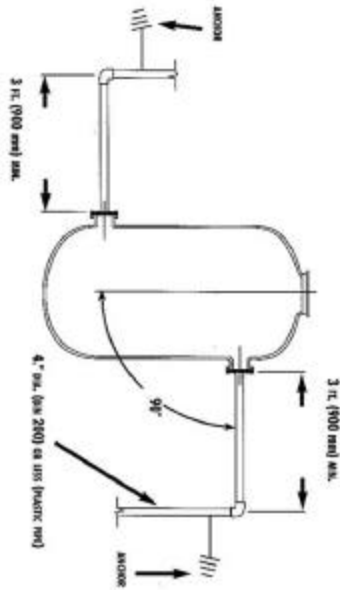

The figures shown here are the acceptable minimum for the pressure vessel at its rated pressure of 150 psig. When using the pressure vessel at a lower pressure, the minimum pipe run length can be reduced, using this formula:

- Multiply pressure vessel pressure in psi x 36
- Divide above by 150
- Result is minimum span of horizontal piping in inches

For example, if the pressure vessel pressure is 120 psi:

- $120 \times 36 = 4,320$
- $4,320$ divided by $150 = 28.8$
- Minimum span of horizontal piping is 29 inches

24

VERTICAL BASE REMOVAL AND REPLACEMENT

FOR:

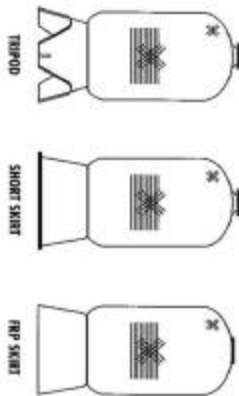

REMOVAL KIT

A kit (#11644) with the required tools and instructions is available for purchase with the replacement base. The kit consists of wooden wedges (2), saw blades (3) with handle, adhesive (Bostic 1000), gloves, safety glasses and a rubber hammer.

REMOVAL

To remove the original base, the pressure vessel must be empty and in the horizontal position. The pressure vessel must be lying on a protective material, such as cardboard, to protect it.

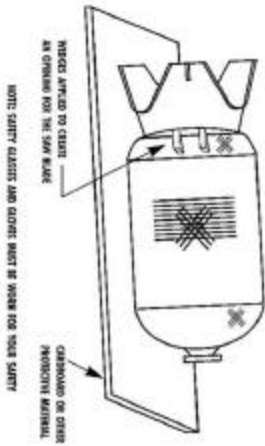

25

VERTICAL BASE REMOVAL AND REPLACEMENT (continued)

1. Drive a wooden wedge between the pressure vessel and the base with the rubber hammer to create an opening to insert the saw blade. If necessary, use the second wooden wedge to make an opening for the saw blade. Have the saw blade teeth toward your hand so that you cut the adhesive with a pulling motion rather than a pushing motion. **Use extreme caution** to avoid injury when performing this step.



NOTE: Use extreme caution to avoid damaging fibers. If fibers are damaged, pressure vessel must **not** be used.

2. As the adhesive is being cut, the wedges must be moved (around the outer diameter of the base) to maintain a gap between the pressure vessel and the base to allow the saw blade to cut the adhesive without getting bound up.
3. After the base is removed, the heavy excess adhesive on the pressure vessel must be removed. Be careful. Do not damage exterior surface of the pressure vessel. It is not necessary to remove all of the old adhesive, but just the heavy excess to allow room for the fresh adhesive. Take your time, the base was installed for the life of the pressure vessel, so it may take a great deal of effort and patience to remove the old base without damaging the pressure vessel.

26

INSTALL THE NEW BASE

1. You must first level the base on a concrete floor. The wooden wedges may need to be used under one or two of the tripod legs to get the base level if the floor is not level.

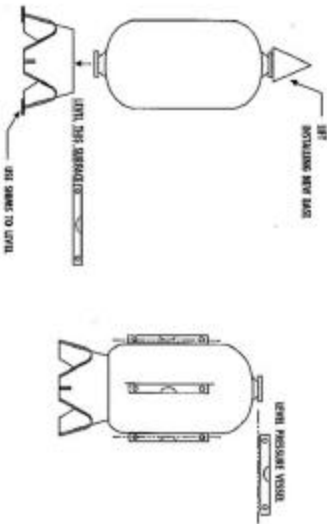

2. The adhesive is applied to the base (with a caulking gun) in a pattern that duplicates the area covered on the old base. The tip of the adhesive tube must be cut to apply the adhesive in a 1/4" diameter minimum.
3. The pressure vessel must be lifted vertically (see drawings on lifting options) and set down onto the base.
4. Level the pressure vessel by using a level on at least 4 points around the outer diameter of the pressure vessel.
5. Once you are satisfied that the pressure vessel is level, the pressure vessel must be allowed to set (undisturbed) for at least 8 hours.
6. Install the pressure vessel.

27

BASIC HANDLING RULES



Never roll or slide a pressure vessel on its side.



Never drop a pressure vessel or allow **hard impact or abrasion** of the pressure vessel from contact with walls, partitions, tools, or equipment.



Hoist operators must follow **proper rigging** procedures.



Avoid use of hooks or equipment on the **inside** of the pressure vessel.



Never fasten **cables or chains** around pressure vessel. Use carvers or nylon straps to avoid damage to the flange area.

STRUCTURAL

The leader in Composite Pressure Vessel Technology
Industrial Parkway • Chardon, OH 44024 U.S.A.
Tel: 440-286-4116 • Fax: 440-286-4331

Section 12 Warranty

Commercial Unit Warranty

All equipment manufactured by WaterGroup Companies Inc. / WaterGroup Inc. is warranted against defects in material or workmanship for the following periods (from date of manufacture)

-Fiberglass tanks - 5 Years

-Brine Tank - 1 Year

-Control Valve and Electronics - 5 Years under normal use and service excluding maintenance items such as pistons, seals, spacers, and brine valves

-Brine Tank Air Check Valve - 2 Years

-All other components are for a period of one year

If a part proves defective within the warranty period, it should be returned to the factory, transportation charges prepaid, together with the serial number of the unit and the model number and a replacement part will be supplied free of charge.

This warranty is limited to the replacement of defective parts, f.o.b. our factory, and does not cover any labor charges or payment for damages.

WaterGroup Companies Inc. / WaterGroup INC. assumes no responsibility for consequential damage, labor or expense incurred as a result of a defect or failure to meet the terms of this warranty because of circumstances beyond its control.

Further, the warranty on any components, not of WaterGroup Companies Inc. / WaterGroup INC. manufacture, is limited to the warranty or guarantee given by the manufacturer of the component.

Use of the product for any purpose other than its intended use will void all warranties.

WaterGroup Companies INC.
580 Park Street
Regina, SK
S4N 5A9

WaterGroup Companies INC.
265 Industrial Road
Cambridge, ON
N3H 4R9

WaterGroup INC.
193 Osborne Road
Fridley, MN.
55432

WaterGroup INC.
9848 Glenoaks Blvd.
Sun Valley, CA
91352

OPERATOR NOTES
