

INSTALLATION MANUAL & OWNER'S GUIDE

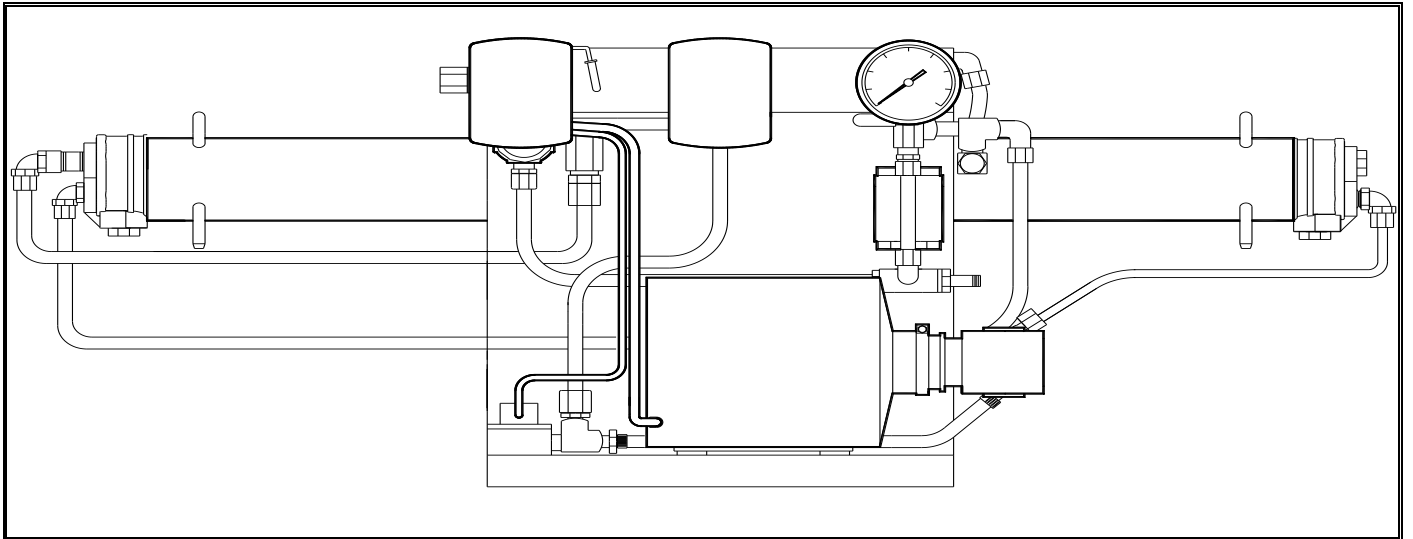

Advanced Reverse Osmosis Water Treatment System



Model Series 111

CM Series
Commercial – Industrial RO Systems

MODELS FROM 2004

265 Industrial Road P.O. Box 5000 Cambridge, ON Canada N3H 5N3	193 Osborne Road Fridley, MN U.S.A. 55432	580 Park Street Regina, SK Canada, S4N 5A9	9848 Glenoaks Boulevard Sun Valley, CA U.S.A. 91352	Toll Free U.S. 800.354.7867 Canada 877.299.5999 www.hydrotechwater.com
--	--	---	--	--

INTRODUCTION

Your new reverse osmosis system was designed with serviceability and ease of installation in mind. It is constructed from the finest materials available.

Installing the system in accordance with these instructions facilitates a speedy, trouble-free installation. The use of approved materials (NSF, FDA) compatible with RO water to install the system will assure the user of quality product water and minimum maintenance.

These procedures are for the use of installers who are familiar with the city, state and local plumbing and electrical codes. If there are any conflicts between the manual and the city, state and local codes, you must follow the codes that are applicable.

Before the installer leaves the facility where the Hydrotech system is installed, explain the operation of the system to the person who will be responsible for the operation, maintenance and record keeping of the system.

Have this person sign and date the form at the back of this manual that he/she understands the working of this equipment. Retain this form for the installers' company records.

CM PART NUMBERING INFORMATION

The part number of the CM series RO systems is based on the exact system configuration. The list below shows how the part number can be broken down to determine exactly which system you have. The first three digits signify that the system is a Series 111 RO, the next three signify the GPD, and the final two digits show the pump type and the system voltage.

111	CM SERIES	030	400 GPD	0	Brass pump	2	115 Volts
		050	600 GPD	1	Stainless Steel Pump	4	230 Volts
		060	800 GPD				
		090	1500 GPD				
		100	2500 GPD				

Example - 111 030 0 2 – CM Series, 400 GPD, Brass Pump, 115 Volt System

INSTALLATION REQUIREMENTS

SYSTEM					
PRODUCTION RATE – gpd (Lpd)	400 (1514)	600 (2271)	800 (3028)	1500 (5678)	2500 (9463)
MEMBRANE TYPE	THIN FILM COMPOSITE (TFC)				
FLOW REQUIREMENTS					
MINIMUM PRESSURE – psi (kPa)	30 (207)				
MINIMUM FLOW – gpm (Lpm)	2.0 (7.6)	3.0 (11.4)	3.0 (11.4)	3.0 (11.4)	4.0 (15.1)
TEMPERATURE RANGE – °F (°C)	40-100 (4-38)				
MINIMUM DRAIN FLOW – gpm (Lpm)	4 (15.1)				
POWER REQUIREMENTS					
MOTOR HOUSEPOWER – HP	1/3	1/2	1/2	1/2	3/4
CURRENT DRAW – amp – 115v (230v)	6 (3)	8 (4)	8 (4)	8 (4)	9 (5)
HERTZ	50-60	50-60	50-60	50-60	60
PHASE	SINGLE				
FEED WATER REQUIREMENTS					
HARDNESS – gpg	<15.00	<15.00	<15.00	<1.00	<1.00
SOFTENER REQUIRED	NO	NO	NO	YES	YES
IRON – mg/L	< 0.10				
MANGANESE – mg/L	< 0.05				
FREE CHLORINE – mg/L	< 0.10				
SILT DENSITY INDEX	< 5.00				
TURBIDITY – NTU	< 1.00				
HYDROGEN SULFIDE – mg/L	0.00				
ORGANICS – mg/L	< 1.00				
TOTAL DISSOLVED SOLIDS – ppm	< 1500				
pH -	3 - 11				
SYSTEM INFORMATION					
SIZE – WIDTH x HEIGHT x DEPTH	31"x15"x15"	53"x15"x15"	53"x15"x15"	53"x15"x15"	53"x15"x15"
WEIGHT – Pounds (Kg)	45 (20)	60 (27)	65 (30)	70 (32)	80 (36)

* A softener is recommended if the supply water hardness is greater than 15 grains per gallon.

Note: A softener will extend the life of the RO membrane when the hardness is greater than 1 grain per gallon.

COMPONENT IDENTIFICATION

1. **POWER SUPPLY:**
115v or 230v
2. **STORAGE CONNECTION:**
This is the product water connection to the storage system.
3. **STORAGE PRESSURE SWITCH:**
Controls the on and off set points of the amount of water pressure applied to the storage tank. This switch is preset with a full tank (off) set point of 60 psi, and an empty tank (on) set point of 40 psi.
4. **OFF/AUTO ON LEVER:**
On or off switch. The up position is off and the down position is the auto on.
5. **LOW/NO PRESSURE SWITCH:**
Protects the pump from running with no/low supply water, which would destroy the pump. This switch is preset by Hydrotech to turn off at 12 psi and on at pressures above 25 psi. Low pressure can cause the system to cycle on and off, which could damage the motor or the pressure switch.
6. **PRESSURE GAUGE:**
Indicates the operating pressure of the system.
7. **PRESSURE REGULATOR/RE-CIRCULATION VALVE:**
Controls the system operating pressure. This regulator is preset for best performance (maximum 200psi). Excess flow is returned to the supply water line.
8. **STORAGE TANK PRESSURE RELIEF VALVE:**
Protects the storage tank from high pressure. If the tank pressure control switch should fail, this valve will open when the tank pressure reaches 85 P.S.I.
9. **PRODUCT CHECK VALVE:**
Protects the membrane from backpressure inside of the membrane envelope.
10. **FLUSH VALVE:**
When open this valve allows the pump output to flow at full velocity (flow) to flush across the membrane surface. This action scrubs the surface of the membrane and sends the concentrated minerals and sediment (fine dirt) that can accumulate on the surface of the membrane to the drain.
11. **CONCENTRATE FLOW CONTROL:**
The concentrate flow control diverts a portion of the concentrate stream to the drain. The flow control is fixed to provide the correct drain flow for the system.
12. **CONCENTRATE (DRAIN) CONNECTION:**
The excess concentrate solution and the flush water connection to the drain air gap.
Note: Do not restrict or stop this flow.
13. **MEMBRANE MODULE:**
The membrane vessel is constructed of stainless steel. The membrane is a thin film composite polyamide material. The TFC membrane can only be used on non-chlorinated water or when the free chlorine has been removed.
14. **SUPPLY WATER CONNECTION.**
15. **SUPPLY WATER SOLENOID.**
16. **MOTOR:**
1/3, 1/2, or 3/4 HP pump motor.
17. **PUMP:**
The pump is a positive displacement type. The pump must be protected by a 5-micron filter to prevent internal damage.

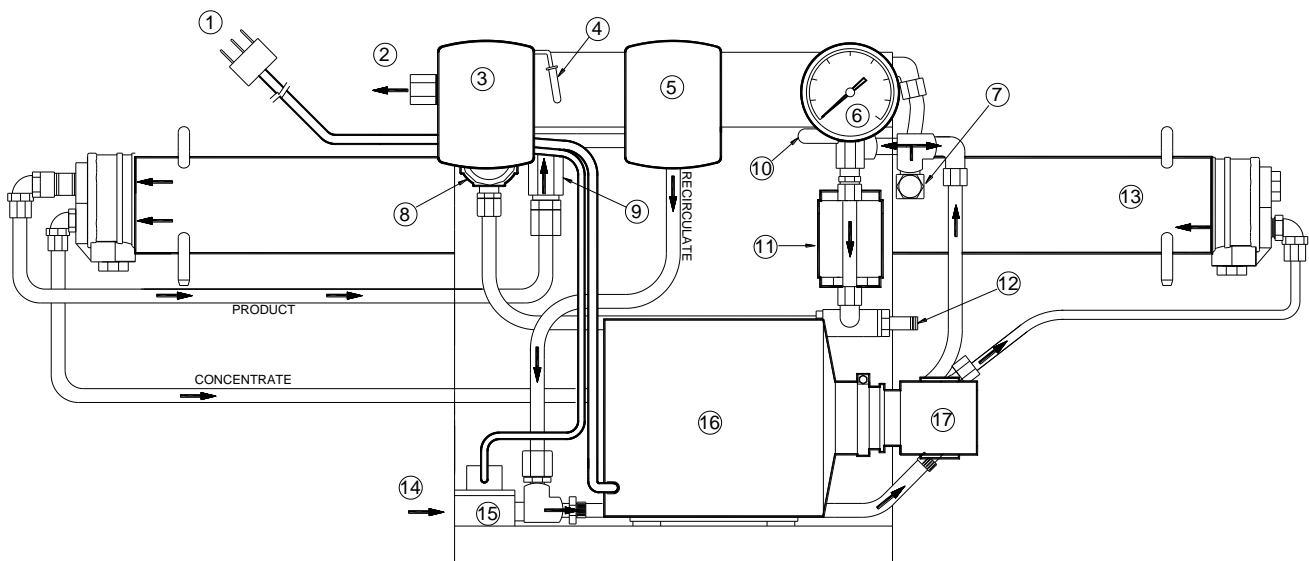

FIGURE 1: CM SERIES BASIC COMPONENTS

PRE-TREATMENT

Pre-treatment of the water supply is recommended to receive the best performance from the Hydrotech RO. Obtain a water analysis from the local water supplier or have a laboratory provide one, this is recommended to help determine the proper pre-treatment. Check the pre-treatment requirements with the water analysis for any conflicts.

If the system requires the installation of a softener, a five-micron sediment filter should be installed just before the RO system (Fig.2)

If the system requires non-chlorinated water and the feed water is chlorinated, install a carbon cartridge filter after the five-micron sediment filter and before the RO. (Fig.3)

If using a backwashing carbon filter, the five-micron sediment filter will have to be installed after the carbon filter and before the RO. (Fig.2)

The pre-treatment is required to protect the system from damage, fouling of the membrane and to decrease the maintenance requirements.

The buyer of the Hydrotech system is responsible for any pre-treatment required to prevent the membrane from fouling, scaling, or deteriorating because of the water chemistry.

PRE-TREATMENT SIZING:

Sizing the pre-treatment is important to RO system performance. The following packages will provide the minimum protection the system will require. Filtration capacity may have to be increased if the supply water has excessive amounts of turbidity, chlorine or other oxidizers, foulents, and contaminants. Check with your local dealer.

NON-CHLORINATED WATER:

GPD	Min. Filter Requirements
400	1 – 10" 5 micron sediment
600	
800	
1500	1 – 20" 5 micron sediment
2500	

CHLORINATED WATER:

GPD	Min. Filter Requirements
400	1 – 10" 5 micron sediment 2 – 10" carbon cartridges
600	
800	1 – 20" 5 micron sediment
1500	2 – 20" carbon cartridges
2500	

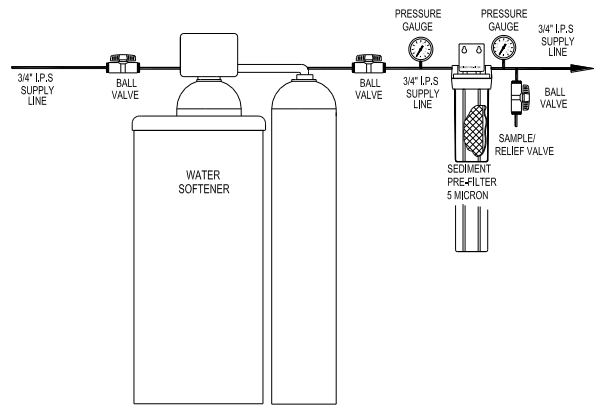

FIGURE 2: NON-CHLORINATED FEED

PRE-FILTER INSTALLATION:

CAUTION: Flush carbon filters before use.

1. Locate the pre-filter close to the RO system on a wall capable of supporting the weight. Ensure that the mounting will support the weight of the filter when full of water.
2. Install a shut-off valve before the pre-filter, so the water supply can be shut off for servicing. All valve porting must be the same inside diameter connecting plumbing.
3. Install a valve (sample/relief/flush) at the exit port of the pre-filter set up (Fig.2, Fig.3).
4. Connect the output of the pre-filter to the RO inlet solenoid valve.
5. Install the filters in the filter housings; make sure the sediment and carbon are in the proper position.
6. Place a bucket under the pre-filter flush valve. Open the supply valve and the flush valve slowly to flush any debris from the filters; flush the filters until the water clears. Close the valves.

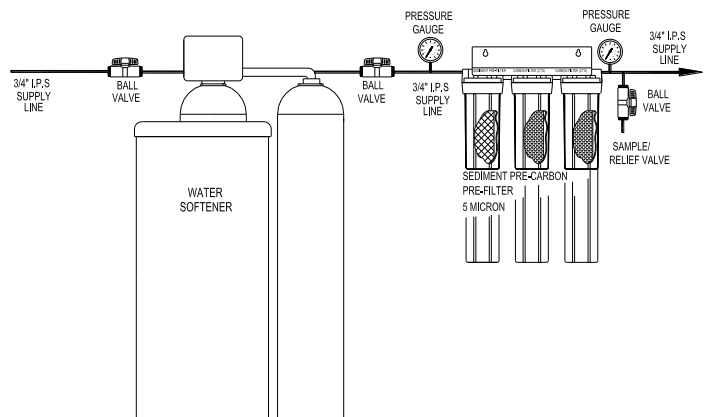

FIGURE 3: CHLORINATED FEED

INSTALLATION PROCEDURES

Place the Hydrotech R.O. equipment in a well-ventilated area (not in a small enclosed cabinet). The required water supply, drain and electrical supply for this system (see pre-installation requirements) should be located as close as possible to the unit. Do not use extension cords. Long runs for the water and /or drain lines must use the appropriate increase in size and capacity to handle the flow and psi.

FEED WATER SUPPLY CONNECTION:

1. Install a supply line from the 5-micron pre-filter system to the solenoid valve port (Fig. 1, #14). Check the pre-installation requirements for the pipe size, pressure and flow of this system. If a softener is required, check the hardness of the supply water to the RO it must be less than one grain per US gallon hard. If this system has a thin film composite membrane and your supply water has been chlorinated, you will have to install a carbon pre-filter to remove the chlorine. This will prevent oxidation and subsequent failure of the membrane.

PRODUCT STORAGE CONNECTION:

1. Install a supply line from the storage connection (Fig.1, #2) to the storage system. This could be a hydro-pneumatic or an atmospheric tank.

2. If sacrificing media post treatment is required, install the post treatment between the R.O. and the storage tank.

DRAIN CONNECTION:

1. Install a line to drain from the concentrate connection (Fig.1, #12) to a suitable drain that will handle the flushing flow rate. Check the pre-installation requirements for this system.

CAUTION: Use of an approved air gap is required, do not put the line directly into a drainpipe or sink. See local plumbing codes.

Do not restrict the drain flow.

ELECTRICAL CONNECTION:

1. Locate an appropriate grounded electrical connection close to the system (check local codes and requirements for the type and size for this system) and connect the grounded power supply (Fig.1, #1). If an atmospheric tank is used connect the power cord to the float connection (Fig.5).
2. Off/Auto On lever: This lever disconnects the power to the pump/motor (Fig1, #4). This lever should be off (up position) when installing the system.

START UP PROCEDURES

1. The product line should be disconnected and run to the drain for the first thirty minutes to flush the system. After all the connections are completed and checked, turn on the supply water valve and check the installation plumbing for leaks. After flushing, reconnect to the storage tank.
2. Move the Off/Auto On lever (Fig.1, #10) on the tank pressure switch to the auto position (vertical position, turn down). The system should start at this time. If the system cycles on and off, move the lever to the off position. The system has a low/no water pressure switch (Fig.1, #6). This switch is preset by Hydrotech to turn the system off at 12 psi (low pressure) and will turn on when the pressure returns to 25 psi. This cycling is caused by low/no water pressure and or low flow of the supply water. This situation must be corrected before the system will operate properly. Increase the flow and pressure to the required parameters for this system to operate properly. Check the pre-installation requirements.
3. The fast flush valve (Fig.1, #14) should be in the open position (vertical position, turn counter

clockwise). This will allow the preservative to flush to drain.

Caution: The motor has an automatic internal thermal overload switch and if activated will automatically restart.

4. After flushing, close the flush valve slowly. The pressure gauge (Fig.1, #14) should show 150 to 200 psi maximum operating pressure. Run the system until it shuts off. The system has a pressure switch (Fig.1, #9) to control the storage tank pressure. This switch is preset by Hydrotech, to turn off at 60 psi and will turn on at 40 psi. If an atmospheric tank is used, the float switch (Fig.5) will shut the system off when the tank is full. Add 6 milliliters of chlorine bleach (5-1/4% chlorine) to every 1 gallon of capacity into the tank, after one-hour drain the tank. This will help sanitize the tank
5. The system is now ready for use. Periodic maintenance is required to enhance the performance and longevity of the Hydrotech RO.

CAUTION: TURN OFF OR DISCONNECT ELECTRICAL SUPPLY PRIOR TO ANY REPAIRS OR ADJUSTMENTS

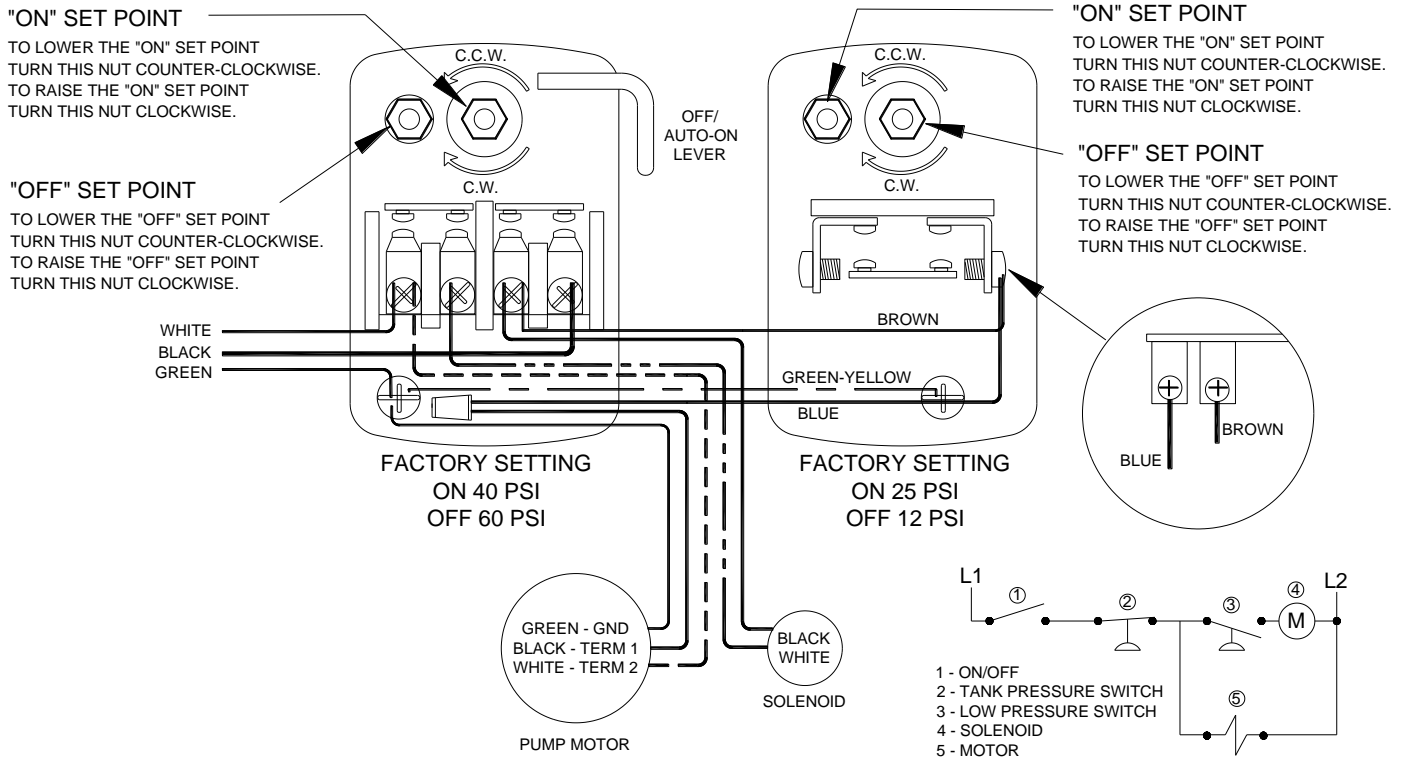

FIGURE 4: ELECTRICAL DIAGRAM

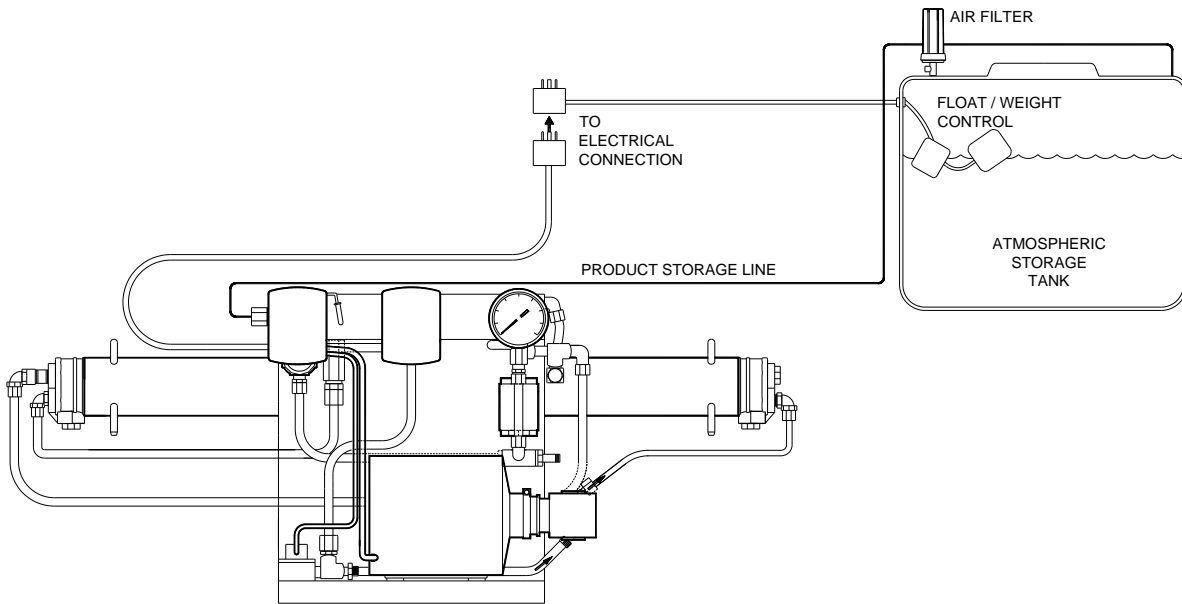

FIGURE 5: ATMOSPHERIC STORAGE TANK CONNECTION

MAINTENANCE

To insure the Hydrotech system continues to operate at the optimum level, a routine maintenance/service schedule must be maintained. The frequency of service will depend on the feed water conditions. For warranty purposes a weekly record of performance may be required (schedule #1) at the back of this manual.

FILTER CHANGES:

1. The sediment pre-filter should be changed as often as necessary to prevent the flow of water from becoming restricted, causing the RO to cycle on/off.
2. The carbon filter should be changed every three months, or more often, depending on the oxidizers, contaminants and the usage of the water.

CAUTION: Flush all granular activated carbon filters before use.

3. Date the filter changes. The Maintenance Schedule at the back of this manual can be used.
4. Turn the power off at the RO tank pressure switch.
5. Turn off the water supply just before the pre-filter.
6. Relieve the pressure in the filter housings(s) by opening the sample / relief valve installed at the end of the filter housing.
7. Remove the filters and dispose of the cartridges.
8. Clean the inside of the filter housings using a mild soap and water. Rinse the filter housing with clean water.

Caution: Do not use abrasives on the plastic components.

9. Disinfect the filter housings. Add ¼ teaspoon of household bleach into the filter housing and fill with clean water. Let stand for 15 minutes, and then discard the water to drain.
10. Replace all o-rings.
11. Place a small amount of an FDA approved o-ring lube on the o-ring and reinsert into the o-ring groove.
12. Replace the filter housings and tighten.

Caution; Do not over tighten the filter housings.

13. After changing the filters, place a bucket under the relief valve. Open the feed water valve and the sample/relief valve. Flush the filters until the water clears. Close the sample/relief valve.

FLUSHING THE MEMBRANE:

HYDROPNEUMATIC TANK:

1. If the system is not running close the hydro-pneumatic storage tank valve.
2. Open any point-of-use valve and leave it open. The system should automatically start.
3. With the system running, open the flush valve (Fig.1, #10) by turning the valve straight down. Let the system flush for 3 minutes. This will scrub the surface of the membrane and send the concentrate to the drain.
4. Close the flush valve. Close the point-of-use valve and open the storage tank valve.
5. The system is now in service.

ATMOSPHERIC TANK:

1. Move the off/auto on lever (Fig.1, #4) to the off position.
2. Disconnect the RO electrical plug from the storage tank connection receptacle and remove the float switch connection receptacle. Replace the RO electrical plug into the wall receptacle (Fig. 5).
3. Move the off/auto on lever to the auto on position. This will start the system.
4. With the system operating, open the flush valve (Fig.1, #10) by turning the valve straight down. Let the system flush for 3 minutes. This will scrub the surface of the membrane and send the concentrate to the drain. Close the flush valve.
5. Move the off/auto on lever to the off position.
6. Remove the RO electrical plug and replace the float switch connection plug. Replace the RO electrical plug into the float switch connection receptacle.
7. Move the off/auto on lever to the on position.
8. The system is now in service.

STORAGE TANKS:

1. Drain storage tanks once a month. This will insure a complete product water exchange.
2. Clean and sanitize storage tanks at least once a year to insure the highest quality of the storage water.

PRESSURE REGULATOR:

1. Lube the piston (Fig.6, #6) and the quad ring (Fig.6, #7) using a non-soluble FDA approved o-ring lubricant every 6 months. More often if the water is high in hardness.
2. Move the off/auto on lever to the off position.
3. Remove the piston guide (Fig.6, #9).
4. Remove piston and quad ring.
5. Lubricate piston and quad ring and replace into piston guide.
6. Replace piston guide and move the off/Auto on lever to the on position.
7. Check operating pressure and adjust if necessary.

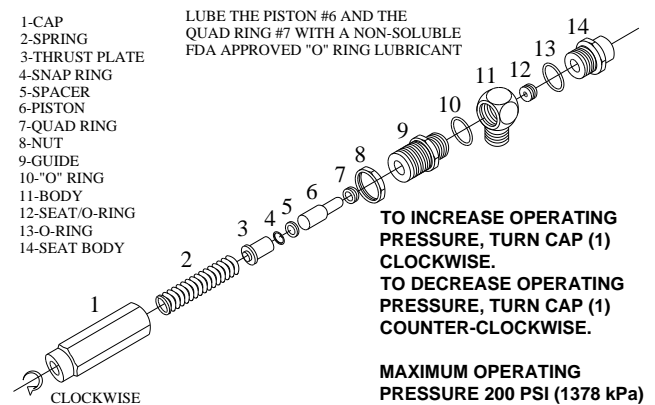

FIGURE 6: PRESSURE REGULATOR

TECHNICAL INFORMATION & IMPORTANT REVERSE OSMOSIS EQUATIONS

1. TOTAL DISSOLVED SOLIDS:

- a. TDS plays a major factor in product water quality since membranes reject a percentage of feed water TDS.
- b. TDS is a major factor in operating pressure.

2. WATER PRESSURE OR FEED PRESSURE

- a. A major factor in determining how fast the RO system filters water. Generally, doubling inlet pressure will double the rate of water production.
- b. Higher water pressure is required as TDS increases. Every 100-ppm of TDS in feed water has the effect of subtracting 1 psi from the operating pressure.

3. TEMPERATURE OF FEED WATER

- a. A major factor in determining how fast the RO system filters water. Often overlooked as reason for insufficient water production. Most RO membranes are rated at 77°F. Product water production rate increases (warmer) or decreases (colder) approximately 1-1/2 % per degree

4. PRODUCT WATER FLOW RATE (GPD).

- a. Use a graduated container (oz or ml) and measure product water for 60 seconds.
- b. Divide the ounces by 128 to obtain gpm.
- c. Divide the milliliters by 3785 to obtain gpm
- d. Multiply gpm by 1440 for gallons per day (gpd).

5. CONCENTRATE WATER FLOW RATE.

- a. Use a graduated container (oz or ml) to measure concentrate water for 60 seconds, Calculate concentrate gpm and gpd

6. PRODUCT /CONCENTRATE RATIO.

- a. To find product/concentrate ratio, divide the concentrate gpd by the product gpd.

Example:

$$\left(\frac{\text{Concentrate}(750)}{\text{Product}(250)} \right) = 3 = 3 \text{ to } 1 \text{ Ratio}$$

7. RECOVERY FORMULA.

- a. To find the % recovery divide the product flow by feed water flow times one hundred (100).
- b. Feed water flow is product plus concentrate

Example:

$$\left(\frac{\text{Product}(250)}{\text{Feed}(750 + 250)} \right) \times 100 = 25 \% \text{ Recovery}$$

8. WATER QUALITY PERCENT REJECTION.

- a. Take a reading on the product water and the supply water (let the system run for 30 minutes before taking these readings). Subtract the product TDS from the supply TDS and divide the answer by the supply TDS, then multiply by 100.

Example:

$$\left(\frac{\text{Supply}(450) - \text{Product}(12)}{\text{Supply}(450)} \right) \times 100 = 97.3 \% \text{ Rejection}$$

9. TEMPERATURE EFFECT ON MEMBRANE.

- a. Membrane production will vary approx. 1-1/2% per degree above or below 77°F.

Example:

$$(77^\circ - 60^\circ) \times 1.5\% = 25.5\% \text{ decrease in product output}$$

10. OSMOTIC PRESSURE.

- a. Osmotic pressure reduces the amount of operating pressure equal to one psi for every 100 ppm of TDS.

Example:

$$\left(\frac{\text{TDS}(1500)}{100} \right) = 15 \text{ psi osmotic pressure}$$

$$\left(\frac{15}{200} \right) \times 100 = 8\% \text{ Reduction in product output}$$

Therefore a 250 gpd system minus 8% will produce approximately 230 gpd product output.

SANITIZING PROCEDURES

Caution: Do not use abrasives on plastic components.

FILTER HOUSING(S):

1. Move the off/auto on lever (Fig.1, #4) to the off position.
2. Close the feed water supply valve and open the relief valve.
3. Remove the filter housing(s).
4. Wash inside of the housing and mounting cap with a solution of dish soap and water.
5. Rinse the inside of the housing and the mounting cap with clean tap water.
6. Add 1/4 teaspoon of unscented household bleach to the filter housing and fill with tap water.
7. Rinse the inside of the mounting cap with the chlorinated solution.
8. Let stand for 30 minutes.
9. Discard the solution to drain.
10. Rinse filter housing and mounting cap with clean tap water.
11. Filter housing is now ready for filter installation.

STORAGE TANK:

Product storage tanks should be sanitized when first installed and at least once a year. Water used for sanitizing should be clean filtered potable water. Unscented household bleach containing 5-1/4% chlorine can be used as a sanitizer. The use of a Hydrotech sanitizer kit is recommended.

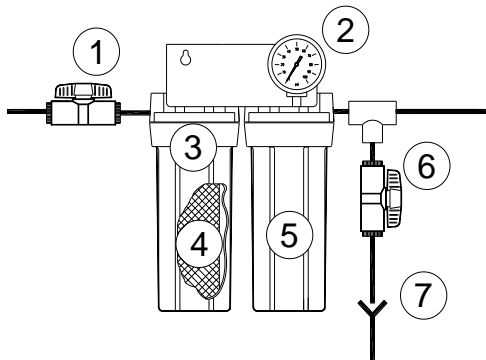

FIGURE 10: SANITIZER KIT

HYDROPNEUMATIC TANK:

1. Move the off/auto on lever (Diagram 1, Item 4) to the off position.
2. Turn the tank valve (Fig.11, #3) to the off position.
3. Connect the output of the sanitizer kit to the inlet to the storage tank (Fig.11, #22).
4. Disconnect the supply lines from the tank at the tee, plug one end of the tee and connect the

Hydrotech sanitizer tubing to the other end of the tee. (Fig. 11, #4)

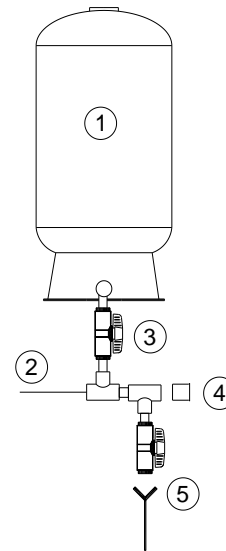

FIGURE 11: HYDROPNEUMATIC TANK

5. Open the supply valve (Fig.10, #1) and fill the tank to 40 psi then close the supply valve.
6. Open the drain valve (Fig.10, #7) on the sanitizer and the storage tank and drain completely.
7. Check the air pressure in the tank for the recommended pre-charge (Table 1).
8. Remove the housing (Fig.10, #5) from the sanitizer and add the sanitizer required (Table 2) for the size of the tank you are sanitizing. Replace the housing. Close the drain valve on the sanitizer kit.
9. Slowly open the supply valve (Fig.10, #1). Leave the valve open until the gauge (Fig.10, #2) shows 40 psi, and then turn off the valve.
10. Let the tank sit for 30 minutes then open the tank drain valve (Fig.11, #5) and empty the tank to drain. Close the valve after entire contents of the tank are drained. Do not use this water.
11. Open the supply valve (Fig.10, #1) and fill the tank to 40 psi.
12. Close this valve and open the sanitizer drain valve (Fig.11, #5). Discard the rinse water to the drain. Do not use this water.
13. For tanks that are severally contaminated repeat lines 8 through 11 several times, depending on the amount of contamination.
14. Reconnect the tank to the RO system and the point of use supply lines.
15. Fill the tank with the RO system product water and discard the first full tank to the drain.

16. The tank is now ready for use.

If the usable volume of the tank is not known, but the volume and pre-charge is known, use the following formula to determine the approximate capacity of the tank in gallons.

$$AC = TV \times \left(1 - \left(\frac{PC + 14.7}{SC + 14.7} \right) \right)$$

Where:

- AC = Approximate tank capacity (gal.)
- TV = Total tank volume (gal.)
- PC = Pre-Charge (psig)
- SC = System Charge (psig) (40 psig)

For Example –

TV = 5 Gallons; PC = 12 psig; SC = 40 psig

$$AC = 5 \times \left(1 - \left(\frac{12 + 14.7}{40 + 14.7} \right) \right)$$

$$AC = 5 \times \left(1 - \left(\frac{26.7}{54.7} \right) \right)$$

$$AC = 5 \times (1 - (.49)) = 5 \times (.51) = 2.6 \text{ Gallons}$$

If you do not have this information, connect the Hydrotech sanitizer kit to the tank. Fill the tank with clean water to 40 psi and measure the capacity of the tank by draining the tank into a measuring bucket

NOTE:

These procedures are to be used as guidelines only. If the storage tanks are contaminated with unknown substances replace the tank.

ATMOSPHERIC TANK:

1. Move the off/auto on lever (Fig.1, #10) on the RO to the off position.
2. Turn off all electrical equipment connected to the storage tank, i.e. UV, ozone, repressurizing pump, recirculation pumps, etc.
3. Turn off the storage tank ball valve (Fig.12, #3) to the supply line and disconnect the supply lines.
4. Connect a line from the tank ball valve (Fig.12, #6) to a drain and drain the tank.
5. Clean the inside of the tank with mild dish soap and clean potable water. Scrub the side, bottom, top, all lines and tubing inside the tank. Do not use abrasive or hard brush bristles that will scratch the tank surface.

6. Rinse the inside of the tank with clean potable water. Make sure the inside of the tank and all components inside the tank are rinsed well.

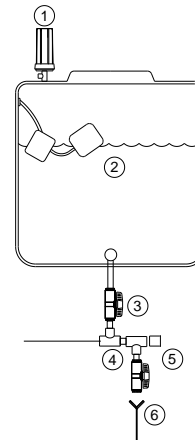

FIGURE 12: ATMOSPHERIC TANK

7. Make a solution of chlorine and clean potable water to sanitize the inside of the tank. See Table 2 for mixing sanitizing solution.
8. Swab the inside of the tank completely and let the solution sit for 15 minutes. Repeat this procedure.
9. Rinse the inside of the tank with clean potable water.
10. Rinse the tank with RO water several times.
11. Reconnect the items that were disconnected at lines 2 and 3.
12. Change the tank air exchange filter (Fig.12, #1) and clean the housing.
13. The tank is now ready for use.

To determine the approximate capacity (AC) of the tank measure the height of the tank in inches (H), and measure the tank circumference, the distance around the tank in inches (C).

The following formula will determine the approximate capacity of the tank in gallons:

$$D(in) = \frac{C(in)}{3.14}$$

$$AC(gal.) = \frac{(785 \times D(in) \times H(in))}{231 \left(\frac{in^3}{gal.} \right)}$$

- 1 Gallon = 231 in³ = 3.785 L
- 1 Gallon of water weighs 8.34 lbs.

NOTE:

These procedures are to be used as guidelines only. If the storage tanks are contaminated with unknown substances replace the tank.

Table 1	
TANK PRE-CHARGE PRESSURE SETTINGS	
Total Tank Volume - Gallons (Liters)	Pre-Charge of Empty Tank PSI (kPa)
3 (11.4)	7 (48)
5 (18.9)	7 (48)
8 (30.3)	7 (48)
11 (41.6)	7 (48)
20 (75.7)	15 (103)
35 (132.5)	15 (103)
40 (151.4)	15 (103)
45 (170.3)	15 (103)

Table 2	
SANATIZING SOLUTION	
RO (or clean filtered water) plus unscented household bleach containing 5 ¼ % chlorine.	
Gallons of H ₂ O - Gallons (Liters)	Bleach - Ounces (Milliliters)
1 (3.79)	0.014 (0.4)
3 (11.4)	0.042 (1.2)
5 (18.9)	0.070 (2.1)
10 (37.85)	0.140 (4.1)
15 (56.78)	0.210 (6.2)
20 (75.7)	0.280 (8.3)
35 (132.5)	0.490 (14.5)
40 (151.4)	0.560 (16.6)
45 (170.3)	0.630 (18.6)

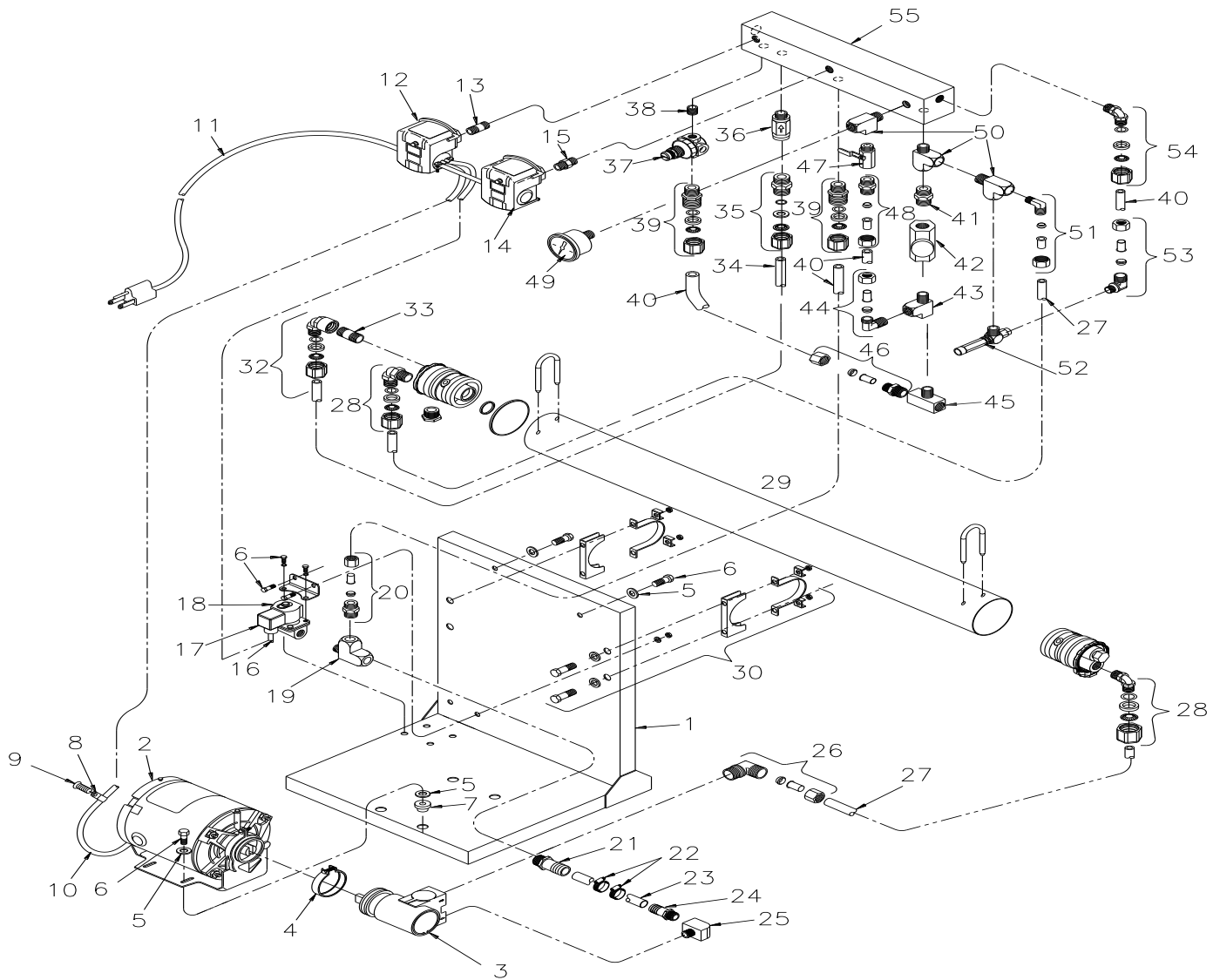

Figure 9 – Exploded View

#	Description	Part Number
1	Frame	31900073
2	Motor - 1/3hp 100-240/50-60 (400 GPD Systems)	34100002
	Motor - 1/2hp 100-240/50-60 (600, 800 and 1500)	34100004
	Motor - 3/4 hp 120-240/60 (2500 GPD Systems)	34100028
3	Pump - 100 GPH (400 GPD Systems)	34300001
	Pump - 100 GPH – Stainless Steel Pump	34300004
	Pump - 165 GPH (600, 800 and 1500 GPD)	34300003
	Pump - 165 GPD – Stainless Steel Pump	34300005
	Pump - 240 GPH (2500 GPD Systems)	34300018
	Pump - 240 GPH – Stainless Steel Pump	34300006
4	Pump clamp	32300004
5	Washer flat 1/4"	32800022
6	Screw 1/4"-20x 3/4"	32101017
7	Nut 1/4"-20 insert	32800017
8	Clamp cord 3/8"	32301017
9	Screw #8x3/8"	32701023
10	Cord motor to switch	60701001
11	Cord to electrical supply (115v)	30800027
	Cord to electrical supply (230v)	60701001
12	Switch storage tank pressure with on/off lever	31400034
13	Nipple - stainless steel	33400012

#	Description	Part Number
14	Switch low pressure	31400003
15	Nipple - brass	33209005
16	Cord power 18-2	60702001
17	Din connector	30800064
18	Valve, solenoid - 120-50/60, 1/2" NPT (115v)	34800032
	Valve, solenoid - 240-50/60, 1/2" NPT (230v)	34800038
19	Street tee 1/2" NPT	33206003
20	Fitting connector 3/8" c x 1/2" NPT	33210010
21	Fitting - 1/2" barb x 1/2" NPT (400 GPD)	33210023
	Fitting - 3/4" barb x 1/2" NPT (600, 800, 1500, and 2500)	33210011
22	Clamp - 1/2" hose clamp (400 GPD)	32301011
	Clamp - 3/4" hose clamp (600,800, 1500, and 2500)	32301012
23	Tubing - Hose gray pvc 1/2" (400 GPD)	60610010
	Tubing - Hose gray pvc 3/4" (600, 800, 1500, and 2500)	60610011
24	Fitting - 1/2" barb x 3/8" NPT (400 GPD)	33210022
	Fitting - 3/4" barb x 1/2" NPT (600, 800, 1500, and 2500)	33210011
25	Fitting - 3/8"NPT street elbow (400 GPD)	33202031
	Fitting - 1/2"NPT street elbow (600, 800, 1500, and 2500)	33202007
26	Fitting - 1/2" c x 3/8" NPT elbow (400 GPD)	33202018
	Fitting - 1/2" c x 1/2" NPT elbow (600, 800, 1500, 2500)	33202017
27	Tubing black nylon 1/2"	60612003
28	Fitting - 1/2" x 3/8" elbow (400 GPD)	33100049
	Fitting - 1/2" x 1/2" elbow (600, 800, 1500, and 2500 GPD)	33100007
29	Vessel Assembly - 2-1/2" x 21" (400 GPD)	33801113
	End plug assembly (Same for 2-12" x 40")	33100084
	Inner o-ring (Same for all Vessels)	34201025
	Outer o-ring (Same for 2-12" x 40")	34202012
	Vessel Assembly - 2-1/2" x 40" (600 and 800 GPD)	33803304
	Vessel Assembly - 4-0" x 40" (1500 and 2500 GPD)	33801112
	End plug assembly	33100085
	Outer o-ring	34201048
30	Vessel Mounting - 2-1/2" (400, 600, and 800 GPD)	40800010
	Vessel Mounting - 4.0" (1500 and 2500 GPD)	40800011
31	Membrane - 400 GPD 2-1/2 X 21	33001070
	Membrane - 600 GPD 2-1/2 X 40	33001009
	Membrane - 800 GPD 2-1/2 X 40	33001404
	Membrane - 1500 GPD 4 X 40	33001042
	Membrane - 2500 GPD 4 X 40	33001046
32	Fitting - Female elbow 1/2" x 3/8" (400 GPD)	33100063
	Fitting - 1/2" Elbow (600, 800, 1500, and 2500 GPD)	33100006
33	Fitting - Nipple 3/8" x 2" (400 GPD)	33601008
	Fitting - Nipple 1/2" x 2" (600, 800, 1500, and 2500 GPD)	33601010
34	Product tube 1/2" gray	60603003
35	Fitting 1/2" x 1/4" NPT	33100044
36	Check valve	35200014
37	Pressure Relief Valve (Storage Tank)	34400016
38	Fitting nipple 1/4"	33601002
39	Fitting connector 3/8"	33100021
40	Tubing 3/8" black	60602005
41	Fitting reducer 3/8" x 1/4"	33209004
42	Flow control needle valve	01005014
43	Fitting tee 3/8"	33206001
44	Fitting elbow 3/8" c x 3/8" NPT	33202002
45	Fitting branch tee 3/8"	33206011
46	Fitting connector 3/8c x 3/8" NPT	33210003
47	Fitting connector 3/8c x 1/4" NPT	33210005
48	Fitting ball valve 1/4"	35200004
49	Gauge operating pressure	34002002
50	Fitting tee 1/4"	33206002
51	Fitting elbow 1/2" c x 1/4" NPT	33202011
52	Recirculation valve	34400001
53	Fitting 3/8" c x 1/8" NPT elbow	33202005
54	Fitting elbow 3/8" x 1/4"	33100003
55	Manifold	32000042

HYDROTECH® TROUBLE SHOOTING GUIDE

Symptom	Possible Causes	Action
System will not run; Pressure switch light is off	<ul style="list-style-type: none"> A. No power to system. B. Off / Auto On Lever in Off position. C. Incorrect voltage. 	<ul style="list-style-type: none"> A. Check power connection; verify that unit is connected to a constant power source (Not an outlet on a switch). B. Move Off / Auto On lever to On position. C. Ensure that the voltage supply is the same as the system requirements.
System will not run; Pressure switch light is on	<ul style="list-style-type: none"> A. Sediment or carbon pre-filters clogged or dirty. B. Feed water supply shut off. C. Low pressure supply. D. Solenoid not opening. 	<ul style="list-style-type: none"> A. Replace any plugged filters. B. Open feed water supply. C. Verify that you have at least 30 psi of supply pressure. D. Verify that solenoid is getting power, check if debris has plugged the solenoid.
System cycles on and off	<ul style="list-style-type: none"> A. Sediment or carbon pre-filters clogged or dirty. B. Low pressure supply. 	<ul style="list-style-type: none"> A. Replace any plugged filters. B. Verify that you have at least 30 psi of supply pressure. Verify that feed water supply is fully open. Verify the supply plumbing is large enough.
No product water	<ul style="list-style-type: none"> A. Flush valve open B. Air pressure in hydro-pneumatic tank too high C. Restriction in post filter D. Membrane not performing properly 	<ul style="list-style-type: none"> A. Flush valve lever should be in the horizontal (Off) position. B. Check tank air pressure setting. C. Check flow through post filters. D. Verify that membrane is receiving adequate water supply. Replace membrane if all else is operational.
Motor overheats	<ul style="list-style-type: none"> A. Improper voltage and amp draw B. Operating pressure above 200 psi. C. System not located in well ventilated area. D. Pump does not turn freely. 	<ul style="list-style-type: none"> A. Verify that system has proper voltage and amp draw. B. Verify that you do not have over 200 psi of operating pressure. C. Relocate system to area with proper ventilation. D. Debris may be clogging pump, check pump and all pre-filtration.
High product water TDS	<ul style="list-style-type: none"> A. O-Ring failure in membrane vessel. B. Membrane failure 	<ul style="list-style-type: none"> A. Check TDS directly at output of membrane. Verify placement of vessel o-rings. Replace as required. B. Replace membrane.

LIMITED WARRANTY

Subject to the conditions and limitations described below, Hydrotech, Inc. warrants its Commercial / Industrial CM Series Reverse Osmosis Systems, when installed in accordance with Hydrotech, Inc. specifications, to be free from defects in materials and workmanship under normal use within the operating specifications for a period of one (1) year from the date of purchase.

Other than the cartridge filters and RO membranes, any part found defective within the terms of this warranty will be repaired or replaced by Hydrotech, Inc. If any part is found defective, Hydrotech, Inc. also reserves the right to replace the RO system with a comparable Hydrotech, Inc. RO system of equal or greater quality. You pay only freight for repaired or replaced parts from our factory and local dealer charges, including but not limited to labor charges, travel and transportation expenses and handling fees. RO Membranes carry a 12 month prorated warranty as follows: Credit 1/12th of the current retail replacement cost for each unused month provided the system is installed and maintained according to Hydrotech requirements.

This warranty shall not apply to any part damaged by accident, fire, flood, freezing, Act of God, bacterial attack, membrane fouling and/or scaling, sediment, misuse, misapplication, neglect, alteration, installation, or operation contrary to our printed instructions, or by the use of accessories or components which do not meet Hydrotech, Inc. specifications. If the drinking water system is altered by anyone other than Hydrotech, Inc., the warranty shall be void.

ALL IMPLIED WARRANTIES, INCLUDING WITHOUT LIMITATION WARRANTIES OF MERCHANTABILITY AND FITNESS FOR PARTICULAR PURPOSE, ARE LIMITED TO THE DURATION OF THE PERIOD SPECIFIED ABOVE FOR THE PARTS DESCRIBED IN THIS LIMITED WARRANTY.

As a manufacturer, we do not know the characteristics of your water supply. The quality of water supplies may vary seasonably or over a period of time. Your water usage may vary as well. Water characteristics can also change if the drinking water appliance is moved to a new location. For these reasons, we assume no liability for the determination of the proper equipment necessary to meet your requirements, and we do not authorize others to assume such obligation for us. Further, we assume no liability and extend no warranties, express or implied, for the use of this product with a non-potable water source or a water source which does not meet the conditions for use as described in this Owners Guide.

HYDROTECH'S OBLIGATIONS UNDER THIS WARRANTY ARE LIMITED TO THE REPAIR OR REPLACEMENT OF THE FAILED PARTS OF THE DRINKING WATER SYSTEM, AND WE ASSUME NO LIABILITY WHATSOEVER FOR DIRECT, INDIRECT, INCIDENTAL, CONSEQUENTIAL, SPECIAL, GENERAL OR OTHER DAMAGES, WHETHER FROM CORROSION OR OTHER CAUSES.

Some states do not allow limitations on how long an implied warranty lasts, so the above limitations may not apply to you. Similarly, some states do not allow the exclusion of incidental or consequential damage, so the above limitation or exclusion may not apply to you. This warranty gives you specific legal rights, and you may have other rights that vary from state to state.



265 Industrial Road P.O. Box 5000 Cambridge, ON Canada N3H 5N3	193 Osborne Road Fridley, MN U.S.A. 55432	580 Park Street Regina, SK Canada, S4N 5A9	9848 Glenoaks Boulevard Sun Valley, CA U.S.A. 91352	Toll Free U.S. 800.354.7867 Canada 877.299.5999 www.hydrotechwater.com
--	--	---	--	---