

All specifications data are per tank

Model	Capacity		Salt Usage				Critical Flow			Dimensions		Installation			Shipping		Operating
	gpg	Resin	@6 lbs/ft ³		@10 lbs/ft ³		95 - 1.25"		Max Flow To Drain	Mineral Tank	Brine Tank	Drain Pipe Size	Height	Depth	Width	Shipping Weight	Operating Weight
	@6 lbs/ft ³	ft ³	lbs	lbs	USGPM	@ 15 PSI	@ 25 PSI	in		in	in						
	@10 lbs/ft ³	m ³	kg	kg	l/s	l/s	USGPM	l/s	l/s	mm	mm	mm	mm	mm	mm	mm	kg
95STS 90-1.5"	66,000	3	18	30	15	25	35	5	14 x 65	24 x 37	1"	81	30	48	332	1,532	
	81,000	0.08	8.2	13.6	0.95	1.58	2.21	0.32	356 x 1651	610 x 940	25	2,057	762	1,219	151	695	
95STS 120-1.5"	88,000	4	24	40	20	27	38	7	16 x 65	24 x 37	1"	81	30	50	430	1,730	
	108,000	0.11	10.9	18.2	1.26	1.70	2.40	0.44	403 x 1651	610 x 940	25	2,057	762	1,270	195	785	
95STS 150-1.5"	110,000	5	30	50	25	32	43	8	18 x 65	24 x 37	1"	83	30	52	501	1,901	
	135,000	0.14	13.6	22.7	1.58	2.02	2.71	0.50	475 x 1651	610 x 940	25	2,108	762	1,321	227	863	
95STS 180-1.5"	132,000	6	36	60	30	31	42	11	21 x 62	29 x 50	1"	83	36	60	623	2,723	
	162,000	0.17	16.4	27.3	1.89	1.96	2.65	0.69	533 x 1575	740 x 1275	25	2,108	914	1,524	283	1,235	
95STS 210-1.5"	154,000	7	42	70	31	31	42	11	21 x 62	29 x 50	1"	83	36	60	679	2,779	
	189,000	0.20	19.1	31.8	1.96	1.96	2.65	0.69	533 x 1575	740 x 1275	25	2,108	914	1,524	308	1,261	
95STS 240-1.5"	176,000	8	48	80	32	32	44	17	24 x 72	29 x 50	1"	91	36	63	798	3,198	
	216,000	0.23	21.8	36.4	2.02	2.02	2.78	1.07	610 x 1829	740 x 1275	25	2,311	914	1,600	362	1,451	
95STS 270-1.5"	198,000	9	54	90	32	32	44	17	24 x 72	33 x 53	1"	91	40	67	866	3,766	
	243,000	0.25	24.5	40.9	2.02	2.02	2.78	1.07	610 x 1829	840 x 1335	25	2,311	1,016	1,702	393	1,709	
95STS 300-1.5"	220,000	10	60	100	32	32	43	17	24 x 72	33 x 53	1"	91	40	67	922	3,822	
	270,000	0.28	27.3	45.5	2.02	2.02	2.71	1.07	610 x 1829	840 x 1335	25	2,311	1,016	1,702	418	1,734	

LEGEND:

- ✕ ISOLATION VALVE
- ⊗ BYPASS VALVE
- ⊕ PRESSURE GAUGE & SAMPLE POINT
- ⌋ OPEN DRAIN
- ⊔ DIAPHRAGM VALVE
- ✱ VACUUM BREAKER
- # FLEX CONNECTORS
- ▶ RAW WATER LINES
- ▶ FILTERED/SOFTENED WATER
- ▶ TREATED WATER LINES
- ⊞ ELECTRIC BALL VALVE

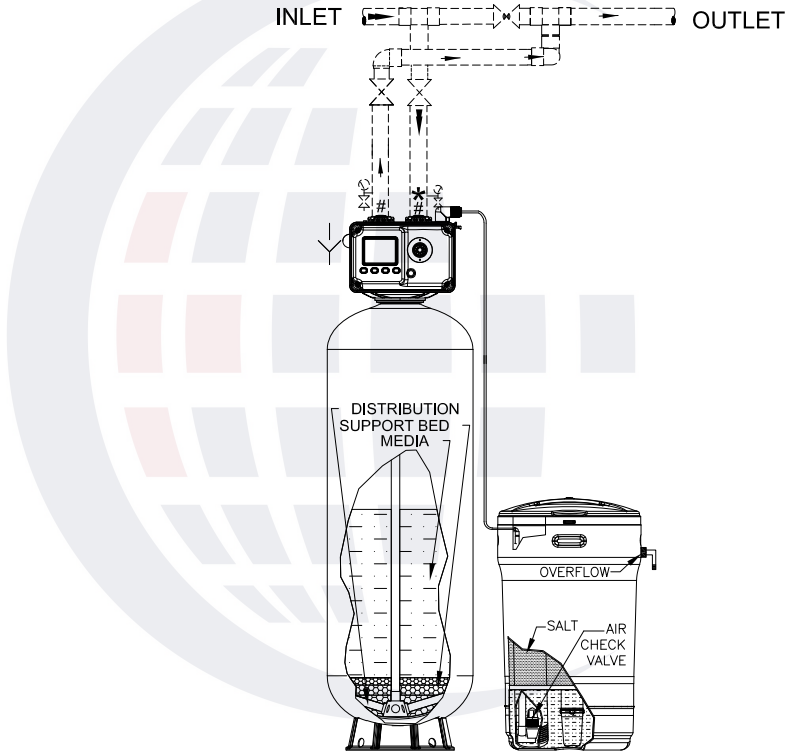

RAW WATER REGENERATION PIPING SHOWN

NOTES:

- SOFTENER(S) EQUIPPED WITH A 95 SERIES ELECTRONIC CONTROL VALVE.
- ALSO AVAILABLE IN 1" AND 1.25" PIPING CONNECTION.
- REQUIRES 120 VOLT, 1 PHASE, 60 Hz ELECTRICAL POWER.
- ALL EXTERNAL PIPING, FITTINGS, INTERCONNECTING PIPING, ISOLATION & SAMPLE VALVES AND GAUGES SHOWN BY BROKEN LINES ARE BY OTHERS
- TANKS AND MEDIA ARE NSF APPROVED.
- RECOMMENDED MINIMUM SYSTEM PRESSURE IS 207 kPa (30 PSI) & MAXIMUM SYSTEM PRESSURE IS 690 kPa (100 PSI). MAXIMUM TEMPERATURE IS 38°C (100°F).
- TRIPOD TANKS TO BE SECURELY ATTACHED TO THE FLOOR.
- "MAX FLOW TO DRAIN" IS BASED ON WATER TEMPERATURES OF 4°C (40°F).
- FLOOR DRAINS MUST BE SIZED TO CARRY THE MAXIMUM LISTED FLOW TO DRAIN.
- REFER TO THE INSTALLATION AND OPERATION MANUAL FOR FURTHER DETAILS.
- SYSTEM MUST BE INSTALLED TO COMPLY WITH ALL FEDERAL, STATE, PROVINCIAL AND LOCAL CODES.
- MINIMUM FREE SPACE OF 152 mm (6") REQUIRED ABOVE VALVE.
- IF USING SYSTEM TREATED WATER REGENERATION, THE BALL VALVE MUST BE INSTALLED ON THE INLET INSTEAD OF THE OUTLET.

- DUE TO SLIGHT EXPANSION AND CONTRACTION OF MINERAL TANKS, PIPING MUST BE DESIGNED TO ALLOW SOME MOVEMENT AS WELL AS PROTECTED FROM VACUUM. FLEX CONNECTORS AND A VACUUM BREAKER MAY BE REQUIRED.
- NOTE: IF NEGATIVE PRESSURE EXCEEDS 5" HG (17 kPa), AN ADEQUATE VACUUM BREAKER MUST BE PROPERLY INSTALLED. FAILURE TO INSTALL FLEX CONNECTION PROPERLY, OR IMPROPER INSTALLATION OF A VACUUM BREAKER WHEN REQUIRED, MAY VOID THE WARRANTY.

MODEL:95STS 240 -1.5" S4000

95STS SOFTENER 1.5" SINGLE SYSTEM

THIS DOCUMENT CONTAINS INFORMATION WHICH IS PROPRIETARY TO CANATURE WATERGROUP. THE REPRODUCTION, TRANSFER, OR OTHER EXPLOITATION OF ANY INFORMATION CONTAINED HEREIN IS NOT PERMITTED WITHOUT PRIOR WRITTEN APPROVAL OF CANATURE WATERGROUP. THE MANUFACTURER RESERVES THE RIGHT TO MAKE PRODUCT REVISIONS, WHICH MAY DEVIATE FROM THE SPECIFICATIONS AND DESCRIPTIONS STATED HEREIN WITHOUT OBLIGATION TO CHANGE PREVIOUSLY MANUFACTURED PRODUCTS OR TO NOTE THE CHANGE. NOT DRAWN TO THE SCALE UNLESS OTHERWISE SPECIFIED.



Project:	Date: 02/21/2024	Rev
	Dwg# 95STS1.5S	0