



LUMINOR™ EVEREST

5.0 / 6.0

Installation & Operation Instructions







**ILLUMINATING
TECHNOLOGIES**
FOR LIFE

Table of Contents

Product Matrix.....	1
Safety Considerations	2
Water Quality Parameters.....	3
System Sizing.....	3
Assembly.....	4
Installation.....	6
Maintenance of UV System.....	8
Cleaning the quartz sleeve	8
Cleaning the UV sensor	9
Operation	10
EVEREST Control Panel	10
EVEREST 3-Position Switch.....	11
EVEREST Power-up Sequence	12
Major Alarm Set Points	12
Minor Alarm Set Points	12
EVEREST Lamp Countdown Sequence	12
EVEREST Lamp Replacement	13
EVEREST Lamp Countdown Reset Sequence.....	13
EVEREST Failure Modes	13
EVEREST Options.....	14
Remote monitoring output definitions.....	14
Flow Curves.....	15
Equipment Specifications	18
Limited Warranty Statement	20
Electrical Schematics for LEX-A42	22
Electrical Schematics for LEX-A62	27
Electrical Schematics for LEX-A72	32

Product Matrix

	 "Normal" 30 mJ/cm ² @ 95% UVT	 Hot Water 30 mJ/cm ² @ 75% UVT	 LOW UVT 30 mJ/cm ² @ 50% UVT	 TOC 150 mJ/cm ² @ 95% UVT
SYSTEM				
4-Lamp "A42" series	LE5-A42	LE5-A42-HW	LE5-A42	LE5-A42-TOC
	LE6-A42	LE6-A42-HW	LE6-A42-50	LE6-A42-TOC
6-Lamp "A62" series	LE5-A62	LE5-A62-HW	LE5-A62	LE5-A62-TOC
	LE6-A62	LE6-A62-HW	LE6-A62-50	LE6-A62-TOC
7-Lamp "A72" series	LE5-A72	LE5-A72-HW	LE5-A72	LE5-A72-TOC
	LE6-A72	LE6-A72-HW	LE6-A72-50	LE6-A72-TOC

Note: Products with "-S" have Sanitary fittings per ASME BPE-2009 TYPE B

Safety Considerations

It is important that care is taken when operating and/or maintaining your system.

Please read the instructions

- The appliance is not to be used by persons (including children) with reduced physical, sensory or mental capabilities, or lack of experience and knowledge, unless they have been given supervision or instruction.
- **WARNING:** During periods of reduced water flow, reactor may be hot.
- Children should be supervised so that they do not to play with the appliance.
- **WARNING:** Do not operate the UV-C emitter when it is removed from the appliance enclosure.
- The appliance is to be supplied through a residual current device (RCD) having a rated residual operating current not exceeding 30 mA.
- This appliance contains a UV-C emitter.
- Unintended use of the appliance or damage to the housing may result in the escape of dangerous UV-C radiation. UV-C radiation may, even in little doses, cause harm to the eyes and skin.
- The appliance must be disconnected from the supply before replacing the UV-C emitter.
- The appliance is intended to be permanently connected to the water mains and not connected by a hose-set.
- Maximum working voltage of built-in UV driver U-OUT=240V
- Before servicing this equipment, disconnect the power.
- Energy given off by the UV lamp is harmful to your eyes and skin. NEVER look directly at an illuminated UV lamp without adequate eye protection and always protect your skin from direct exposure to the UV light.
- Use ONLY genuine replacement parts.
- Do not operate the unit if it has any damaged or missing components.
- To avoid possible electrical shock, ensure the unit is properly grounded.
- Never perform any maintenance to the system unless you are comfortable in doing so. Contact the manufacturer for service instructions if required.
- Do not use this system for any purpose other than what it was intended for. Misuse of this system could potentially cause harm to the user or others.
- This system is intended to be installed indoors and away from leaking plumbing. DO NOT power the unit if the system or any of the components are wet.
- We recommend that a licensed plumber or certified technician install the system.

THIS PRODUCT IS NOT TO BE USED FOR GENERAL LIGHTING / ILLUMINATION.

Before you begin

Water Quality Parameters

Treated water should be tested for at the least the parameters listed below. If the water exceeds the listed parameters LUMINOR strongly recommends that appropriate pretreatment equipment be installed (equipment required will depend on parameters being treated):

Hardness: <7GPG (120 mg/L) – if hardness level is 7 GPG (grains per gallon) or slightly below the quartz sleeve must be cleaned periodically in order to ensure efficient UV penetration, if above the water must be softened.

Iron (Fe): <0.3 ppm (0.3 mg/L)

Manganese (Mn): <0.05 ppm (0.05 mg/L)

Turbidity: < 1 NTU

Tannins (organics): <0.1 ppm (0.1 mg/L)

UVT (transmittance): >85% (Please contact LUMINOR if your water has a UVT that is less than 80% for pre-treatment recommendations)

Chlorine (Cl): <4 ppm (4.0 mg/L)

You can have your water tested at a private analytical laboratory or by your local dealer. It is always recommended to install pre-filtration of at least 5 microns prior to a LUMINOR UV system.

System Sizing

All LUMINOR UV Systems are rated for a specific flow under specific water quality parameters. The equipment has been designed to ensure that the appropriate dose will be delivered provided all the parameters are met. *PLEASE NOTE that unless a flow restrictor is part of the installation, the system may pass more water through the system than what the system is rated at. If this happens, the system may be delivering a UV dose level that is below what may be expected. As a result, the maximum flow specified in the equipment specifications should be strictly adhered to (a lower flow is not a concern as the dose will increase due to a longer contact time).

***Please note:** It is always better to oversize your UV system than to undersize. There will come a time where the water demand will reach the system's maximum capacity.

Assembly

Step 1: Unpack the system and ensure all the components are included with the system. Your system is shipped with the following components:

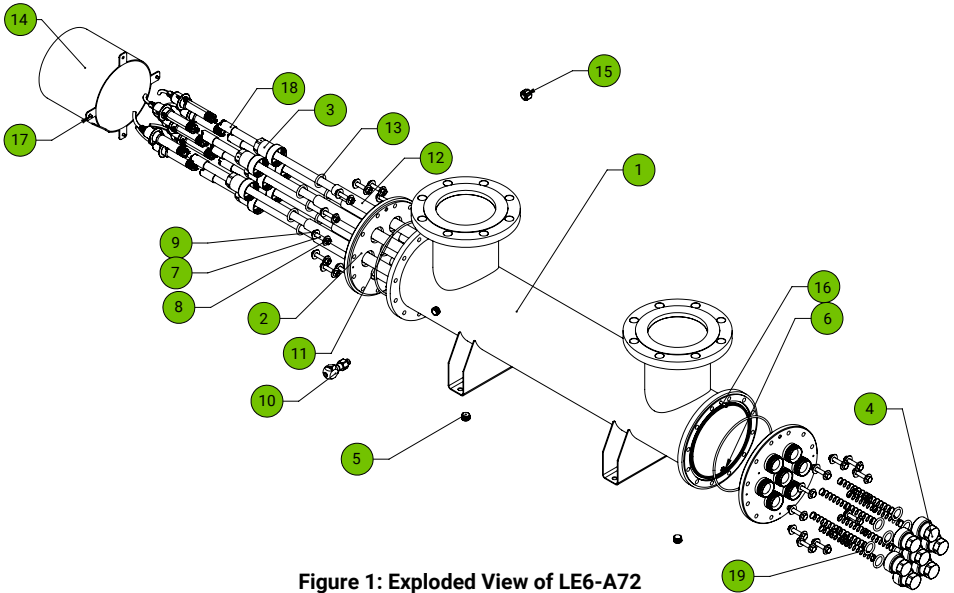

Figure 1: Exploded View of LE6-A72

Item	Description	Item	Description
1	Weldment, LEX-AX2, 8" 316 SS	11	O-Ring, Everest 8" chamber (310090)
2	Front Plate	12*	Quartz sleeve (RQ-K2)
3*	Gland nut, T6, open (300046)	13*	O-Ring, T-6 gland seal (310043)
4*	Gland nut, T6, closed (310042)	14	End cap, 8" Everest chamber
5	Plug, 3/4" NPT socket head, SS (390018)	15	Plug, assy, sensor port (2 for LE5) (300016)
6	Plug, 1/4" NPT socket head, SS (390019)	16	Roll pin, 1/4"OD x 1-5/8", 302 SS (390023)
7	Bolt, 3/8"-16 UNC x 2" hex head cap screw, SS (390020)	17	Screw, 10-32 x 3/8" stainless steel Phillips drive pan head (390040)
8	Nut, 3/8"-16 UNC, SS (390021)	18*	Lamp (RL-1000A / RL-1000A-TOC)
9	Washer, 3/8", SS (390022)	19*	Spring (3x per sleeve) (310206)
10	Sensor (LE6 only) (RS-EUV)		

Figure 2: Bill of Materials and replacement parts for EVEREST

*Please note that quantities required for these items depend on the number of lamps in the system.

Step 2: All four, six, and seven lamp configurations use the same control panel, for consistent and simple installation. **PLEASE NOTE:** All LUMINOR UV systems are intended for indoor use only as they should not be exposed to the elements.

Step 3: There is only one size of EVEREST control panel, regardless of system size purchased. Find a suitable location to mount the panel.

Step 4: Ensure that the UV reactor and control panel are mounted in accordance with local regulations and with suitable hardware.

Each of the four, six, and seven lamp configurations utilize the same chamber, for consistent and simple installation.

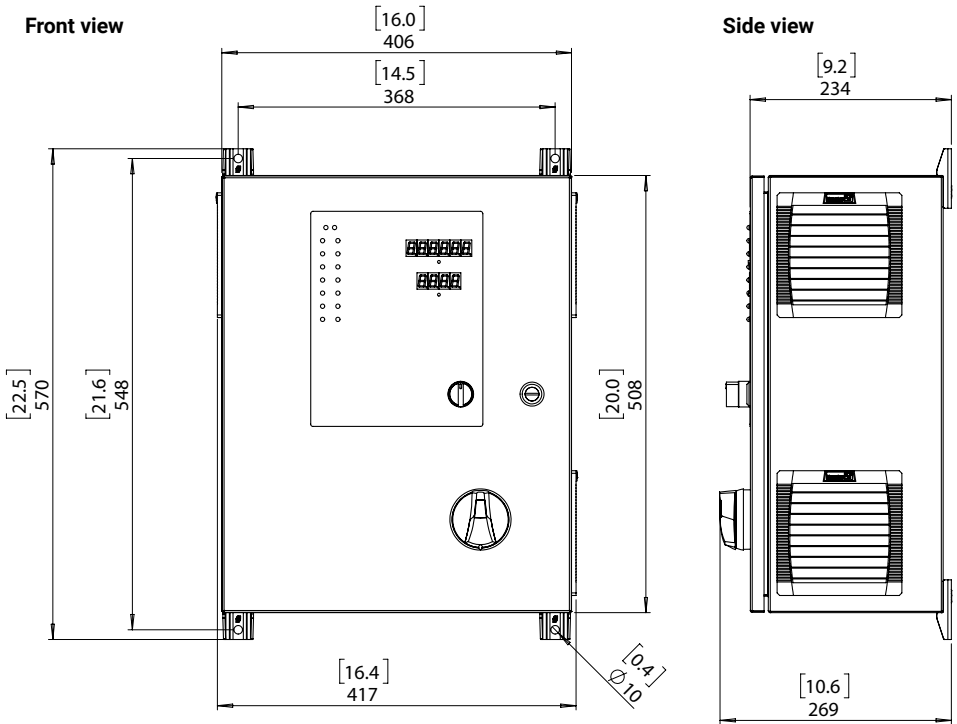
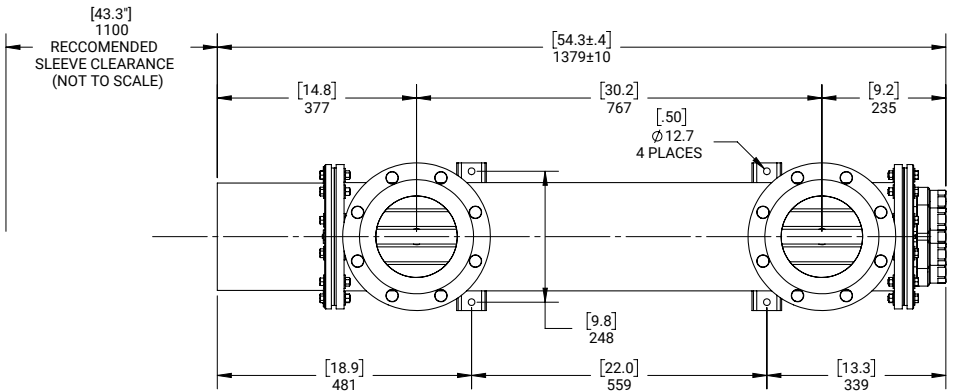

Figure 3: EVEREST Control Panel Dimensions



**Figure 4: LE5-A6/72 Chamber with showing sleeve clearance.
4 lamp systems require the same sleeve clearance.**

Installation

The UV system can be installed in many configurations, and is equipped with vent ports to eliminate hot air pockets in any orientation.

Step 1: The UV system should always be the last piece of treatment before the water branches off to hot or cold-water lines.

Step 2: LUMINOR strongly recommends that a 5 micron filter be installed **BEFORE** the UV system for final polishing step before the water is treated.

Step 3: The reactor can be installed either horizontally or vertically, however horizontal installation is the preferred method (**Figure 5a**) with the inlet at the bottom as it allows any air that may be in the lines to be easily purged from the UV system.

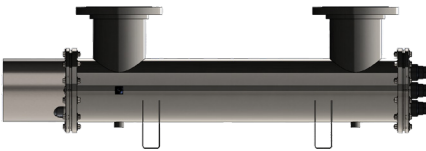

Figure 5a: Preferred installation orientation



Figure 5c: Alternate orientation. Ensure chamber is vented

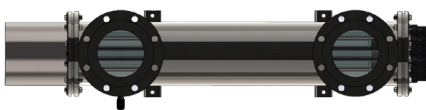

Figure 5b: Alternate orientation. Ensure sensor is on the bottom and chamber is vented

Step 4: If you do not know the flow rate of the water supply in the application, it is recommended that you use a flow restrictor so that the rated flow of your particular EVEREST system is not exceeded, and the UV dose is not compromised. The flow restrictor should be installed on the outlet port of the reactor.

Step 5: The system is shipped with the quartz sleeves installed in the chamber and has been pressure tested at the factory to 150 PSI. **PLEASE NOTE:** Do not install a UV lamp inside the quartz sleeve without the sleeve springs in place.

Step 6: (Applicable only if you have a UV sensor). Carefully remove the sensor from its packaging and insert the sensor into the UV sensor port (**Figure 6**). There are two sensor ports on the chamber. It is recommended to install on the bottom port if the chamber is installed horizontally to avoid air bubbles in front of the sensor. The sensor can only go in one way. Ensure that the flat portion of the UV sensor matches up with the half metal lip on the sensor port (flat portion should face the lamp connection end) (see Figure 6) Ensure that the sensor is fully seated in the sensor port and then tighten (turning clockwise) the sensor nut. **PLEASE NOTE:** DO NOT over tighten the nut as this could damage the Teflon sensor body. Plug the male connector into the sensor port located on the bottom of the control panel.

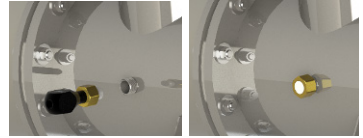

Figure 6: LE6 Sensor installation (left), LE5 Glow Plug installation (right)

Step 7: The reactor is now ready for water flow. **WARNING:** Sudden filling of an empty reactor could potentially break the protective quartz sleeves. It is strongly recommended to gradually fill the empty reactor. Damage because of sudden filling is not covered under warranty. When all plumbing connections have been completed you should check for any possible leaks. Slowly turn on the water supply and check for leaks. Make sure the by-pass valves are functioning properly and that the water is flowing through the reactor. The most common leak is from the O-rings (**Figure 7**) not making a proper seal on the reactor. If this is the case turn the water off, drain the reactor, remove each O-ring, dry them and reapply silicon grease. Replace each O-ring ensuring they are properly sealed against the reactor, retighten the gland nuts and check again for leaks. **WATER-HAMMER WARNING:** Quartz sleeves can break inside the reactor if water-hammer occurs. Water hammer is caused by sudden closing of valves elsewhere in the piping system. It is strongly recommended to ensure that the piping and valve system is designed to prevent water-hammer. Damage due to water-hammer is not covered by warranty.

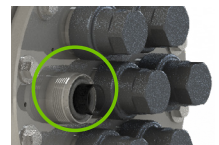

Figure 7: O-ring installation on sleeve

Step 8: The control panel can now be mounted on the wall. It should always be above or beside the reactor to ensure that no moisture can deposit on any of the connections. The control panel can be mounted up to 8 feet away from the reactor. The control panel requires a single phase, 208-240VAC 50/60Hz connection and should be hardwired in accordance with local electrical code.

Step 9: Now you can remove the UV lamp from its packaging being careful not to touch the lamp quartz with your hands. Again, the use of cotton gloves is recommended to avoid depositing oils on the lamp glass. Always hold the lamp by the ceramic ends. Carefully insert the UV lamp into the reactor sliding it inside the quartz sleeve located inside the reactor. (Do not drop the lamp into the reactor).

Step 10: Before the lamp is completely inserted into the sleeve, affix the lamp to the lamp connector as shown in Figure 7. Affix the LUMI-Loc™ connector into the gland nut by aligning the arrows with the pins in the nut and turning connector ¼ turn to lock the connector to the gland nut.



Figure 8: Connecting socket to lamp base

Step 11: One lamp connector has a ground terminal. Affix the ground screw to the ground lug on the UV reactor. Local codes may require additional grounding for the piping system.

Step 12: Affix “Danger: Hot” label to the reactor.

Step 13: Your system is now ready to be powered on.

Maintenance of UV System

Cleaning the Quartz Sleeve

Depending on the water quality, the quartz sleeve may require periodic cleaning. At a minimum, the quartz sleeve should be cleaned on an annual basis. The following steps outline a basic cleaning procedure.

Step 1: If the system has an inlet shut-off valve, shut this valve off to prevent water flowing through the system. If there is not an inlet shut-off valve, turn off main water inlet valve (and turn off water pump if you have one).

Step 2: Power off the system at the main disconnect.

Step 3: Close the outlet shut-off valve and release the water pressure by slowly opening one of the drain ports.

Step 4: Completely drain the system of all water.

Step 5: Remove the captive ground screw from the ground lug on the UV reactor.

Step 6: Remove the lamp connector from the reactor (gland nut) by pushing the LUMI-Loc connector in and turning it ¼ turn counter-clockwise.

Step 7: Pull the lamp out of the reactor still attached to the connector.

Step 8: Remove the gland nut from each end of the reactor exposing the ends of the quartz sleeve.

Step 9: Carefully remove the O-ring from the end opposite from the lamp connection and then pull the quartz sleeve out of the reactor (ensure no water enters the inside of the quartz sleeve; remove the second O-ring)

Step 10: Using a soft, lint-free cloth or towel wipe the sleeve down using CLR® or LIME-A-WAY® (or other commercial scale cleaner) to remove any scaling or iron deposits that may be on the outside of the quartz sleeve. Be careful not to get any moisture or liquids on the inside of the sleeve.

Step 11: Wipe the sleeve with separate dry cloth.

Step 12: Once the sleeve is cleaned slide it back into the reactor.

Step 13: Replace both O-rings, and repressurize the system.

Cleaning the UV Sensor

Depending on the water quality, the UV sensor may require periodic cleaning. At a minimum, the UV sensor should be cleaned on an annual basis. The following steps outline a basic cleaning procedure.

Step 1: If the system has an inlet shut-off valve, shut this valve off to prevent water flowing through the system. If there is not an inlet shut-off valve, turn off main water inlet valve (and turn off water pump if you have one).

Step 2: Power off the system at the main disconnect.

Step 3: Close the outlet shut-off valve and release the water pressure by slowly opening one of the drain ports.

Step 4: Completely drain the system of all water.

Step 5: Unscrew (counterclockwise) sensor nut from the reactor and pull the sensor slowly out of the sensor port.

Step 6: Holding the sensor in your hand wipe the flat portion (sensor face) of the sensor with isopropyl alcohol using a clean lint-free cloth.

Step 7: Replace sensor as per instructions on page 7.

Operation

The LUMINOR Everest system comes with a feature laden control system that incorporates both the lamp drivers (ballasts) and control features in one modular panel. **CAUTION:** Prior to performing any maintenance on your UV system, you must always disconnect power with the red disconnect switch.

EVEREST Control Panel

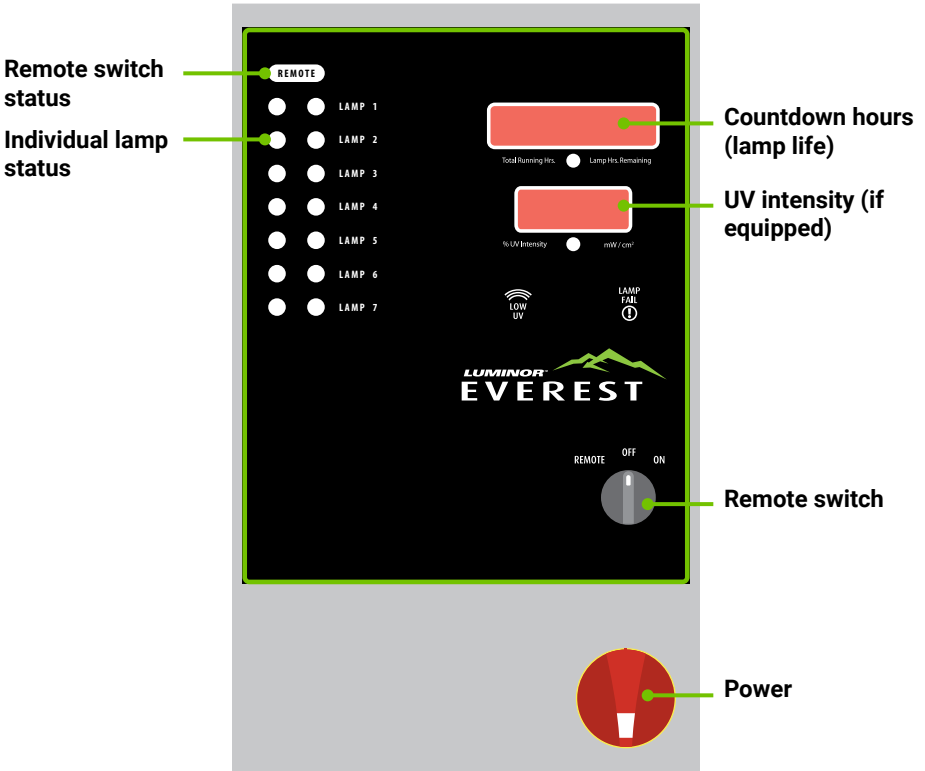

The control panel features power factor corrected and constant current lamp drivers. Simplistic in operation, the panel features an LED display for remaining lamp life, total running hours, audible and visual lamp failure, remote on and solenoid ready. When the UV lamps are on, the LEDs on the panel will indicate the status of each lamp. If any lamp is "OFF" and audible alarm will sound.

Please Note: If the LED reads "OFF" and the alarm is sounding then the UV water from the system should NOT be consumed. If any water does pass through the UV system during this period, treatment of the downstream system may be required. It should also be noted that on the EVEREST5.0 system even though this system does have a visual and audible warning built into the controls, the LED reading "ON" does not necessarily indicate that the water coming from this system is in fact potable (safe to drink). This

system does not measure the level of disinfection; it simply measures the “ON-OFF” status of the lamp. For a constant reassurance of safe water quality, you should consider the EVEREST6.0 as it comes equipped with a UV sensor (you can also add the optional RS-EUV sensor on all EVEREST5.0 systems). Please have your water checked for microbiological contaminants on a regular basis.

EVEREST 3-position Switch

The control panel features a 3-position user-selectable switch. This switch is NOT a power switch. The red disconnect switch or breaker should be used prior to servicing the equipment

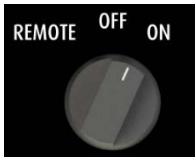

“ON” position

Power is supplied to the lamps and the controller will read “ON” on the lower LED display on units without a UV sensor installed and will read the intensity (or UV output) on units with a UV sensor installed. Please note that when first starting the lamps, the system will cycle through a declining numerical sequence while

the lamps reach full power.

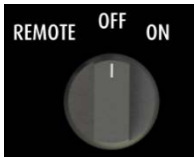

“OFF” position

Power is NOT supplied to the lamps and the lamps will be off. The controller will be reading “OFF” on the lower LED display.

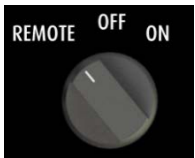

“REMOTE” position

In this position, the control of the unit is placed in a remote location (i.e., a computer) via an added remote cable. Through this cable, the operator must supply a 24-volt power source that will allow these “dry contacts” to operate. The screens and the “ON” and “OFF” functions will now be all operated remotely. While the

UV controller is in the remote position, **EXTREME CAUTION** must be exercised around the UV reactor while servicing the UV lamps as they may be turned on or off remotely without the operator’s knowledge or control. As a result, it is not recommended to service the lamps while the controller is in the “REMOTE” mode. The system should be physically disconnected from the power source, or the controller should be manually switched to the “OFF” position while servicing the lamps.

EVEREST Power-up Sequence

The system will countdown from 180 seconds while the lamps are warming up.



If dry contacts are being used, the following logic will apply. The EVEREST control panel will indicate when the system is ready for treatment by the indicated countdown on the bottom LED screen. During the countdown the “Ready for flow” logic is “NO”. After 180 seconds, the “Ready for flow” logic is “YES” and the system will operate as intended.



If your system is equipped with a UV sensor, your EVEREST control panel will display the UV output in either “% UV Intensity” or “mW/cm²”. The default output is “%UV Intensity” and to toggle between these two outputs, simply press the button located directly beneath the bottom LED screen. The UV output LED screen will indicate the level of UV intensity that is being detected within the reactor by the sensor. This will always be visible on the front of the control panel. Things that can affect the UV Output are poor water quality, scaling of the quartz sleeve and/or sensor, lamp failure, expired lamp life and sensor failure.

When the UV output drops to 60%, the system will display a “LOW UV” warning light in yellow and the system will emit an intermittent audible chirp to signal this “LOW UV” condition. When the UV output drops to 50% the system will display a “LOW UV” warning light in red and the system will emit a constant audible alarm to signal this critical “LOW UV” condition. Additionally, at this point, the controllers also provides a signal to de-activate the flow of water if implemented in the system. When the system registers a low UV condition, the only way to silence the alarm is to correct the reason for the low UV condition.

Major Alarm Set Points:

Contact factory for details.

Minor Alarm Set Points:

Contact factory for details.

EVEREST Lamp Countdown Sequence

The **EVEREST** control panel has a countdown feature that displays the number of hours remaining until a lamp change is required. When the lamp has 512 hours remaining, the display will flash indicating that the lamp is nearing end of life. At “zero hours remaining”, the system registers and audible alarm. If you wish to silence this audible alarm condition, simply press, and hold down the button located directly beneath the top LED screen for a period of three seconds. **PLEASE NOTE:** During the condition of lamp expiration, the water may be unsafe for consumption.

EVEREST Lamp Replacement

After the lamp is expired, it must be replaced with the same part number as indicated by the label on the reactor. Begin replacing the lamp by disconnecting the power for the controller, then refer to Installation for instructions on installing the new lamp.

EVEREST Lamp Countdown Reset Sequence

After changing all lamps on the EVEREST system, hold down the button located directly beneath the top LED screen for a period of fifteen seconds and then restart power to the system.

EVEREST Failure Modes

The EVEREST control panel continuously monitors your UV system and if there is a problem with the system the panel will provide both a visual and audible signal indicating the specific fault that may be adversely affecting the operation of your system. The fault conditions are listed in a priority sequence as follows:



LAMP FAILURE

If at any time during the operation of the system, the UV lamps fail to be illuminated, the controller will return both an audible and visual signal indicating lamp failure. In addition, a constant audible buzzer will sound during lamp failure.



UV SENSOR FAILURE

Assuming the system has a UV sensor installed, if at any time during the operation of the system, a UV sensor fails, the controller will return a "FAIL" indicator on the bottom LED screen and a constant audible buzzer will sound during sensor failure.

EVEREST Options

Additional monitoring is possible by wiring directly into the control panel. A 4-20mA output is built into the controller. This reports the UV intensity as an analogue output. If the system is in alarm, the dry contacts can be used to confirm operational state remotely. Please refer to the schematics for specific details.

Remote Monitoring Output Definitions

4, 6 or 7 Lamp Systems

Condition	UV%	mW/cm ² (Note 1)	Alarm	Fault Relay	Reactor Ready Relay	4-20mA Value (Note 2)
Lamps ON	100%	40	NO	OK	YES	20mA
Lamps ON	90%	36	NO	OK	YES	18.4mA
Lamps ON	80%	32	NO	OK	YES	16.8mA
Lamps ON	70%	28	NO	OK	YES	15.2mA
Lamps ON, Low UV	60%	24	MINOR	FAULT	YES	13.6mA
Lamps ON, Low UV	50%	20	MAJOR	FAULT	NO	12mA
Lamps ON, Low UV	40%	16	MAJOR	FAULT	NO	10.4mA
Lamps ON, Low UV	30%	12	MAJOR	FAULT	NO	8.8mA
Lamps ON, Low UV	20%	8	MAJOR	FAULT	NO	7.2mA
Lamps ON, Low UV	10%	4	MAJOR	FAULT	NO	5.6mA
Lamps ON, Low UV	0%	0	MAJOR	FAULT	NO	4mA
Lamp Off	N/A	N/A	NO	OK	NO	20mA

Note 1: The values provided are theoretical values, the true value will be within $\pm 5\%$ of this value. This can vary among different systems.

Note 2: The values provided are theoretical values, the true value will be within $\pm 10\%$ of this value. This can vary among different systems.

Flow Curves

LE5/6-A42

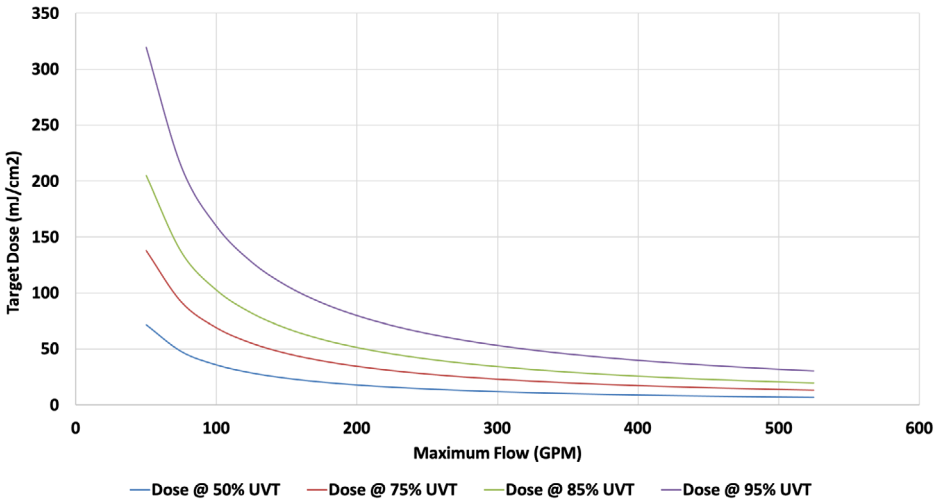

LE5/6-A62

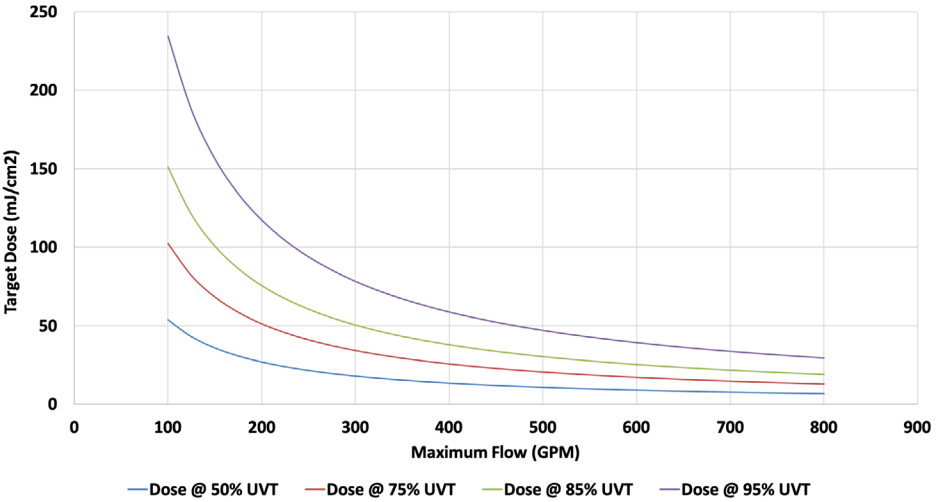

LE5/6-A72

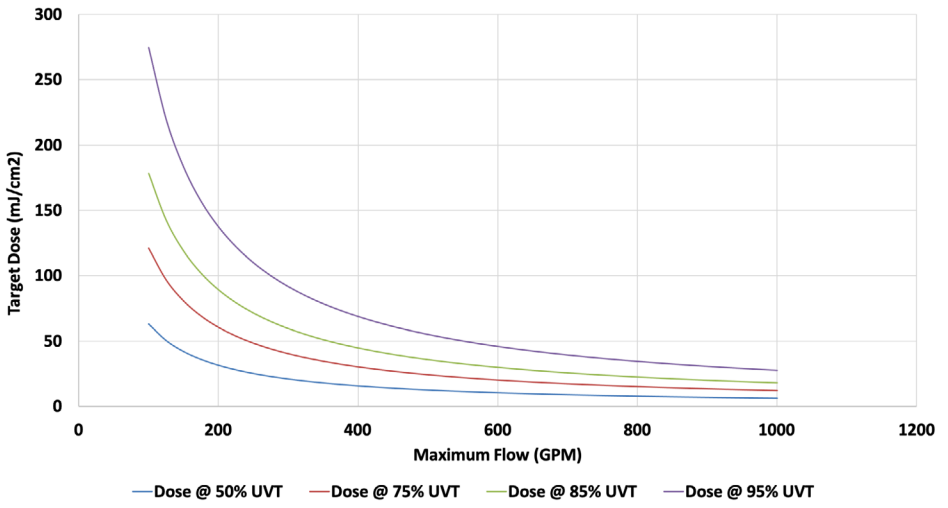



LUMINOR EQUIPMENT SPECIFICATIONS

EVEREST, Commercial/Industrial Amalgam UV systems

MODEL ¹	LE5 (non-monitored)	LEX-A42 LEX-A42-50 LEX-A42-TOC	LEX-A62 LEX-A62-50 LEX-A62-TOC	LEX-A72 LEX-A72-50 LEX-A72-TOC
	LE6 (UV-monitored)			
Normal Flow Rate 30 ml/cm ² @ 95% UVT		530 GPM (2013 lpm) (120.8 m ³ /hr.)	780 GPM (2957 lpm) (177.4 m ³ /hr.)	915 GPM ¹ (3468 lpm) (208.0 m ³ /hr.)
Hot Water Flow Rate 30 ml/cm ² @ 75% UVT		230 GPM (870 lpm) (52.2 m ³ /hr.)	341 GPM (1292 lpm) (77.5 m ³ /hr.)	404 GPM (1530 lpm) (91.8 m ³ /hr.)
LOW UVT Flow Rate 30 ml/cm ² @ 50% UVT		119 GPM (452 lpm) (27.1 m ³ /hr.)	179 GPM (679 lpm) (40.7 m ³ /hr.)	210 GPM (796 lpm) (47.7 m ³ /hr.)
TOC Flow Rate 150 ml/cm ² @ 98% UVT		122 GPM (462 lpm) (27.7 m ³ /hr.)	179 GPM (679 lpm) (40.7 m ³ /hr.)	209 GPM (793 lpm) (47.6 m ³ /hr.)
Alternate flow @ 16 ml/cm² at 95% UVT (US Public Health)		997 GPM ² (3775 lpm) (226.5 m ³ /hr.)	1464 GPM ² (5545 lpm) (332.7 m ³ /hr.)	1717 GPM ² (6502 lpm) (390.1 m ³ /hr.)
Alternate flow @ 40 ml/cm² at 95% UVT		400 GPM (1510 lpm) (90.6 m ³ /hr.)	586 GPM (2218 lpm) (133.1 m ³ /hr.)	687 GPM (2601 lpm) (156.0 m ³ /hr.)
Port Size	6" Flange (150lb, RF ANSI)			
Electrical	208 - 240V ± 10% / 50-60Hz (hard wired)			
Total Lamps Power (Watts)	828		1242	1449
Total System Power (Watts)	900		1340	1560

Replacement Lamp (disinfection @ 254 nm)	RL-1000A (4 used)	RL-1000A (6 used)	RL-1000A (7 used)
Replacement Lamp (TOC @ 185 nm)	RL-1000A-TOC (4 used)	RL-1000A-TOC (6 used)	RL-1000A-TOC (7 used)
Replacement Quartz Sleeve	RQ-K2 (4 used)	RQ-K2 (6 used)	RQ-K2 (7 used)
Reactor Material	316L Stainless Steel, A249 Pressure Rated Tubing, Polished & Passivated		
Control Panel Dimensions	16.4 x 22 x 10.6" (42 x 56 x 27 cm)		
Control Panel Material	304 Stainless Steel		
Reactor Dimensions*	54.3 x 18.0 x 10.75" (1379 x 457.6 x 273.1 cm)		
Drain Ports	YES, qty 2 - ½" FNPT		
Maximum Operating Pressure	10.3 bar (150 psi)		
Optimum Water Temperature	2-40° C (36-104° F)		
254nm UV Intensity Monitor	Optional / Upgradeable (LE5 Models), Yes (LE6 Models)		
Remote-On	YES (DIN Rail Terminal Blocks)		
Dry Contacts (solenoid ready)	YES (DIN Rail Terminal Blocks)		
4-20 mA Output	YES (DIN Rail Terminal Blocks)		
Lamp Age Counter	YES		
Visual/Audible Lamp-Out Indicator	YES		
Audible Lamp-Out Alarm	YES		
Lamp/UV Sensor Cable Length	Standard @ 3.05 m (10')		
Shipping Weight	275 lbs (125 kg)		

Note: ¹ Based on a flow velocity of 8.2 ft/s (2.5 m/s), flow rates are limited to 883 gpm.

² Flow rates for lower doses may not be achievable. Contact factory for custom port sizing.

Our sizing is based on standard ideal average dose calculation and 80% lamp efficiency at end of life.

NOTE: Electrical certification optional for various markets.

* Dimensions are for reference only, and may be revised by LUMINOR without notice.

Limited Warranty Statement

Products manufactured by LUMINOR Environmental Inc., (LUMINOR) are warranted to the original user only to be free of defects in material and workmanship for a period as specified below. This warranty only applies to the original purchaser and is not transferable.

UV SYSTEMS

Ten (10) year Limited Warranty on the stainless steel reactors, from the date of original purchase, or installation (proper documentation required for verification).

ELECTRONICS

Three (3) year Limited Warranty on the ballasts and controllers, from the date of original purchase, or installation (proper documentation required for verification).

UV LAMPS, UV SENSORS & QUARTZ SLEEVES

One (1) year Limited Warranty on all LUMINOR ultraviolet lamps, UV sensors and quartz sleeves from the date of original purchase, or installation (proper documentation required for verification).

LUMINOR warrants that it will repair, replace or refund, at LUMINOR's sole option, any ultraviolet system or component that is defective in materials or workmanship for the period as outlined above, subject to the "Limitations of Warranty" as outlined below. LUMINOR's liability under this warranty shall be limited to repairing or replacing at LUMINOR's option, without charge, F.O.B. LUMINOR's factory or authorized service depot, any product that LUMINOR manufactures. LUMINOR will not be liable for any costs of removal, installation, transportation, or any other charges which may arise in connection with a warranty claim. Products which are sold but not manufactured by LUMINOR are subject to the warranty provided by the manufacturer of said products and not by LUMINOR's warranty. LUMINOR will not be liable for damage or wear to products caused by abnormal operating conditions, accident, abuse, misuse, unauthorized alteration or repair, or if the product was not installed in accordance with LUMINOR's installation and operating instructions.

LIMITATIONS OF WARRANTY

This warranty does not apply to any of the following:

- Water Quality Parameters lie outside of the following ranges:
 - Hardness > 120 mg/L (7 gpg)
 - Iron > 0.3 mg/L (ppm)
 - Manganese > 0.05 mg/L (ppm)
 - Tannins > 0.1 mg/L (ppm)
 - Turbidity > 1 NTU
 - Transmittance (UVT) < 75%
 - Chlorine <4 ppm (4.0 mg/L)
- A product that has been incorrectly installed according to the owners manual.
- A product that has been modified in any manner, unless approved by the manufacturer.

- A product where the serial number has been altered defaced or removed.
- Damage caused by the use of parts that are not compatible, suitable and/or authorized by LUMINOR for use with the product (e.g., non-original lamps or sleeves).
- Damage caused during shipment of the product.
- Water damage is found inside ballast housing or controllers.
- Product is installed outdoors in direct contact with the environment (rain).
- Product is installed in freezing temperatures.
- Product is used in conditions that exceed LUMINOR's specifications.

TO GET WARRANTY SERVICE

To obtain service under this warranty, you must first contact where the product was originally purchased to obtain a Return Goods Authorization. You will require proof of purchase and installation date, failure date, and any other requested data. Unless otherwise provided, the Dealer or Distributor will contact LUMINOR for instructions on returning the product. Any defective product to be returned to LUMINOR must be sent freight prepaid; documentation supporting the warranty claim and/or a Return Goods Authorization must be included if so instructed.

LUMINOR WILL NOT BE LIABLE FOR ANY INCIDENTAL OR CONSEQUENTIAL DAMAGES CAUSED BY FIRE, FLOOD, OR ACTS OF GOD, LOSSES, OR EXPENSES ARISING FROM INSTALLATION, USE, OR ANY OTHER CAUSES. THERE ARE NO EXPRESS OR IMPLIED WARRANTIES, INCLUDING MERCHANTABILITY OR FITNESS FOR A PARTICULAR PURPOSE, WHICH EXTEND BEYOND THOSE WARRANTIES DESCRIBED OR REFERRED TO ABOVE.

THIS LIMITED WARRANTY IS THE SOLE AND EXCLUSIVE WARRANTY MADE BY LUMINOR WITH

RESPECT TO THE PRODUCT, AND IS GIVEN IN LIEU OF ANY OTHER WARRANTY. TO THE EXTENT ALLOWED BY APPLICABLE LAW, ANY AND ALL EXPRESS OR IMPLIED WARRANTIES NOT SET FORTH HEREIN ARE WAIVED AND DISCLAIMED, INCLUDING ANY IMPLIED WARRANTY OF MERCHANTABILITY OR FITNESS FOR A PARTICULAR USE. LUMINOR LIABILITY UNDER THIS LIMITED WARRANTY IS LIMITED SOLELY TO THOSE LIABILITIES SET FORTH ABOVE. IN THE EVENT THAT ANY PROVISION OF THIS LIMITED WARRANTY SHOULD BE OR BECOME INVALID OR UNENFORCEABLE UNDER APPLICABLE LAW, THE REMAINING TERMS AND CONDITIONS HEREOF SHALL REMAIN IN FULL FORCE AND EFFECT AND SUCH INVALID OR UNENFORCEABLE PROVISION SHALL BE CONSTRUED IN SUCH A MANNER AS TO BE VALID AND ENFORCEABLE.

Electrical Schematics for LEX-A42

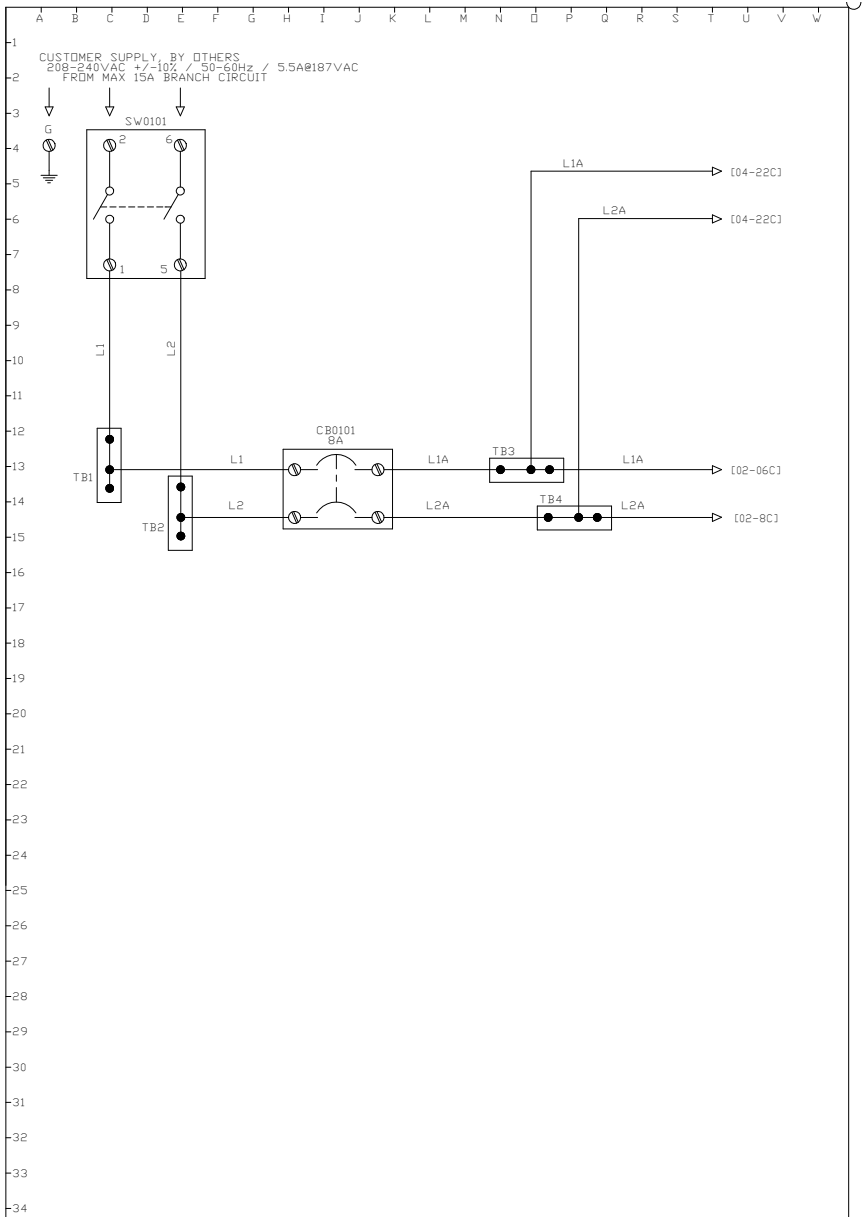

B	UPDATE LABELS AND REFLECT AS-BUILT	TEB	2023-08-29
A	RELEASE FOR PRODUCTION	TEB	2023-08-09
REV.	REV. DESCRIPTION	REV BY	DATE
DESCRIPTION CONTROL PANEL, EVEREST, 4-LAMP SCHEMATIC			
PROJECT	DRAWING NO LEX-A42	SHEET 01	REV B



COPYRIGHT © 2023 BY LUMINOR ENVIRONMENTAL, INC. QUELUP, ONTARIO, CANADA. ALL RIGHTS RESERVED. NO PART OF THIS DOCUMENT MAY BE REPRODUCED, STORED IN A RETRIEVAL SYSTEM, OR TRANSMITTED IN ANY FORM, WITHOUT THE WRITTEN PERMISSION OF LUMINOR ENVIRONMENTAL, INC.

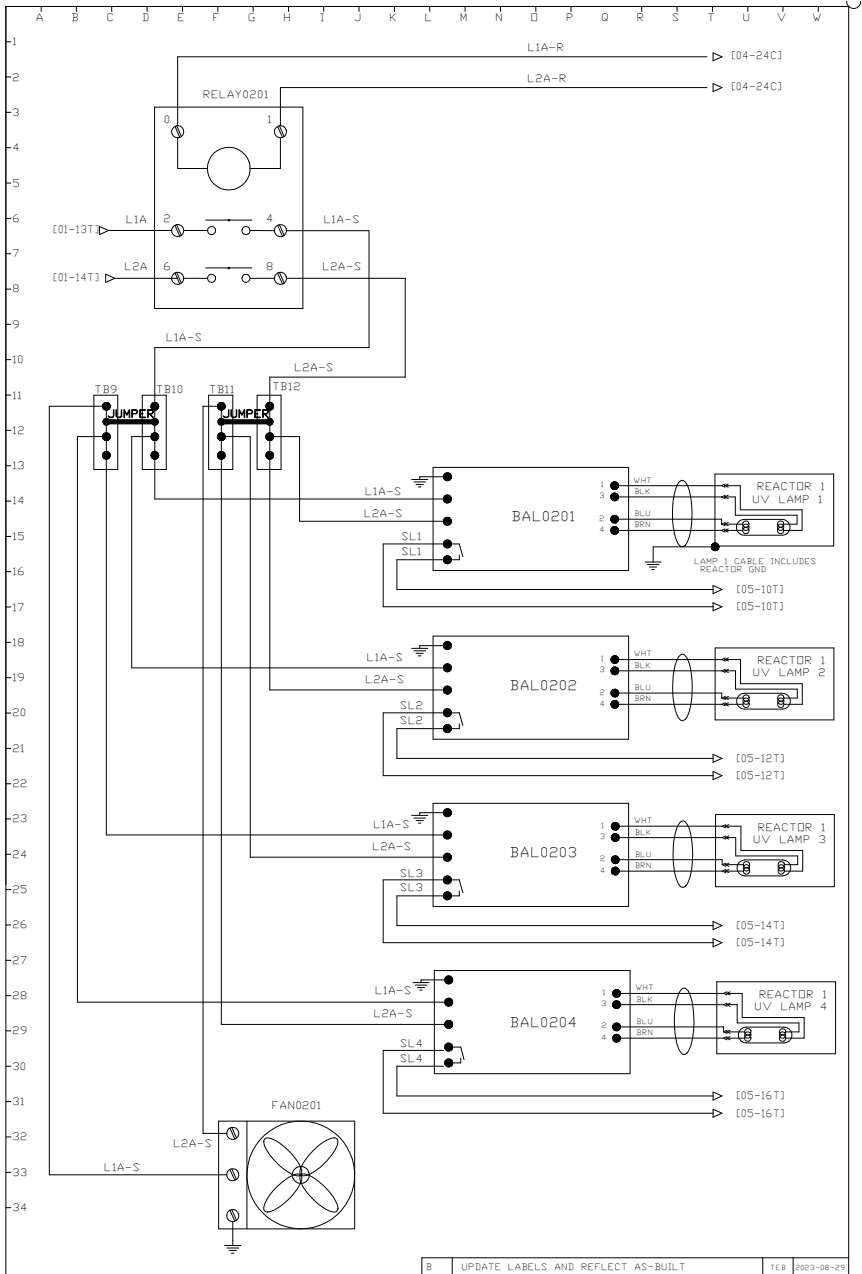

B	UPDATE LABELS AND REFLECT AS-BUILT	TEB	2023-08-29
A	RELEASE FOR PRODUCTION	TEB	2023-08-09
REV.	REV. DESCRIPTION	REV. BY	DATE
DESCRIPTION CONTROL PANEL, EVEREST, 4-LAMP SCHEMATIC			
PROJECT:	DRAWING NO: LEX-A42	SHEET: 02	REV. / B



COPYRIGHT © 2023 BY LUMINOR ENVIRONMENTAL, INC. QUEBEC, QUEBEC, CANADA. ALL RIGHTS RESERVED. NO PART OF THIS DOCUMENT MAY BE REPRODUCED, STORED IN A RETRIEVAL SYSTEM, OR TRANSMITTED IN ANY FORM, WITHOUT THE WRITTEN PERMISSION OF LUMINOR ENVIRONMENTAL, INC.

THIS PAGE
INTENTIONALLY LEFT
BLANK

B	UPDATE LABELS AND REFLECT AS-BUILT	TEB	2023-08-29
A	RELEASE FOR PRODUCTION	TEB	2023-08-09
REV.	REV. DESCRIPTION	REV BY	DATE
DESCRIPTION CONTROL PANEL, EVEREST, 4-LAMP SCHEMATIC			
PROJECT:	DRAWING NO. LEX-A42	SHEET 03	REV. B



COPYRIGHT © 2023 BY LUMINOR ENVIRONMENTAL, INC. QUEBEC, QUEBEC, CANADA. ALL RIGHTS RESERVED. NO PART OF THIS DOCUMENT MAY BE REPRODUCED, STORED IN A RETRIEVAL SYSTEM, OR TRANSMITTED IN ANY FORM, WITHOUT THE WRITTEN PERMISSION OF LUMINOR ENVIRONMENTAL, INC.

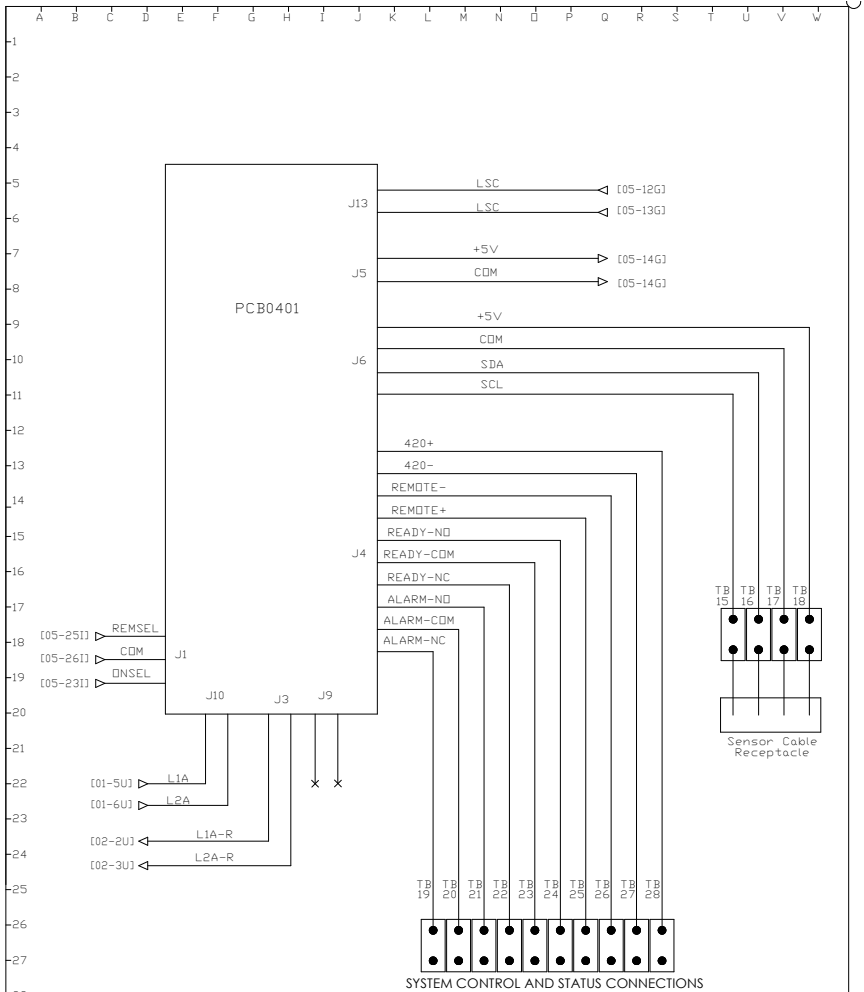

SYSTEM CONTROL AND STATUS CONNECTIONS - TECHNICAL INFORMATION

Relevant Pins	Parameter	Value
ALARM-NC, ALARM-NO, ALARM-COM, READY-NC, READY-NO, READY-COM	Max Rated Current	2.5A
	Max Contact Resistance	100 ma
	Contact Insulation	750V
	Typical Coil Voltage	24 VDC
REMOTE+, REMOTE-	Max Coil Current	16 mA
	Coil Insulation	750 VAC
	Loop Voltage	8-24 VDC
420+, 420-	Nominal Transduced Current Range	4-20 mA
	Current Tolerance	15%

B	UPDATE LABELS AND REFLECT AS-BUILT	TEB	2023-08-29
A	RELEASE FOR PRODUCTION	TEB	2023-08-09
REV.	REV. DESCRIPTION	REV. BY	DATE
DESCRIPTION CONTROL PANEL, EVEREST, 4-LAMP SCHEMATIC			
PROJECT:	DRAWING NO. LEX-A42	SHEET: 04	REV: B



COPYRIGHT © BY LUMINOR ENVIRONMENTAL INC. QUEBEC, QUEBEC, CANADA. ALL RIGHTS RESERVED. NO PART OF THIS DOCUMENT MAY BE REPRODUCED, STORED IN A RETRIEVAL SYSTEM, OR TRANSMITTED IN ANY FORM, WITHOUT THE WRITTEN PERMISSION OF LUMINOR ENVIRONMENTAL INC.

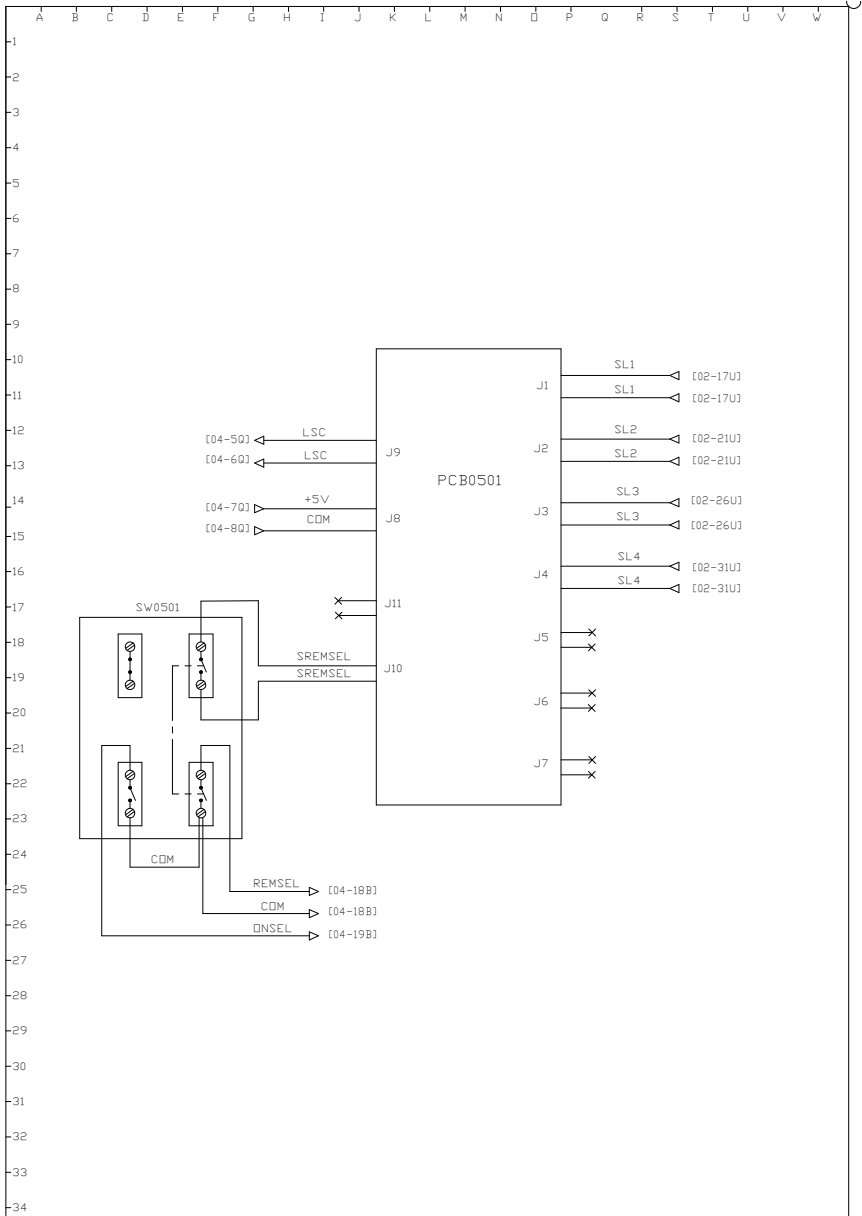

B	UPDATE LABELS AND REFLECT AS-BUILT	TEB	2023-08-29
A	RELEASE FOR PRODUCTION	TEB	2023-08-09
REV.	REV. DESCRIPTION	REV. BY	DATE
DESCRIPTION CONTROL PANEL, EVEREST, 4-LAMP SCHEMATIC			
PROJECT:	DRAWING NO. LEX-A42	SHEET 05	REV. B



COPYRIGHT © 2023 BY LUMINOR ENVIRONMENTAL INC. QUEBEC, QUEBEC, CANADA. ALL RIGHTS RESERVED. NO PART OF THIS DOCUMENT MAY BE REPRODUCED, STORED IN A RETRIEVAL SYSTEM, OR TRANSMITTED IN ANY FORM, WITHOUT THE WRITTEN PERMISSION OF LUMINOR ENVIRONMENTAL INC.

Electrical Schematics for LEX-A62

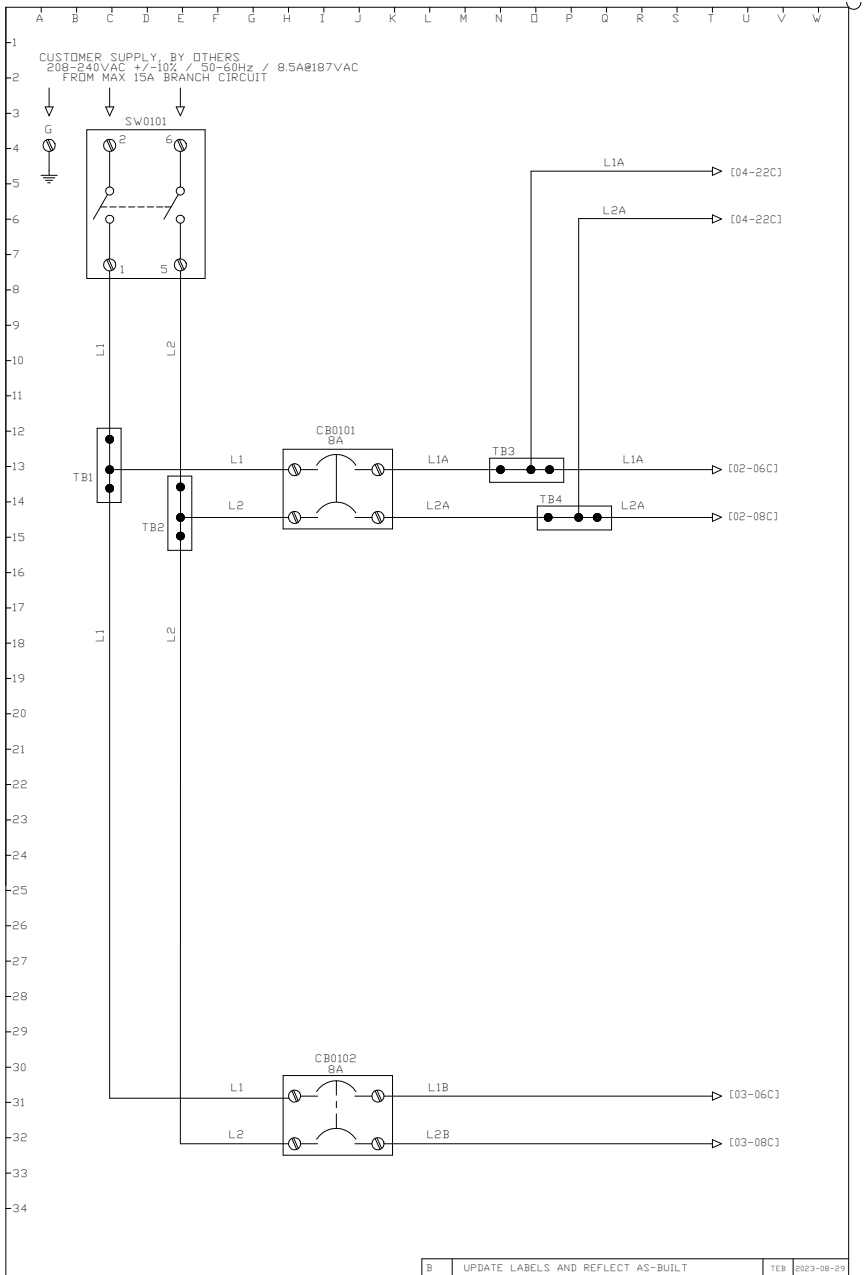

B	UPDATE LABELS AND REFLECT AS-BUILT	TEB	2023-08-29
A	INITIAL RELEASE	TEB	2023-07-13
REV.	REV. DESCRIPTION	REV BY	DATE
DESCRIPTION CONTROL PANEL, EVEREST, 6-LAMP SCHEMATIC			
PROJECT	DRAWING NO	SHEET	REV
	LEX-A62	01	B



COPYRIGHT © 2023 BY LUMINOR ENVIRONMENTAL, INC. QUEBEC, QUEBEC, CANADA. ALL RIGHTS RESERVED. NO PART OF THIS DOCUMENT MAY BE REPRODUCED, STORED IN A RETRIEVAL SYSTEM, OR TRANSMITTED IN ANY FORM, WITHOUT THE WRITTEN PERMISSION OF LUMINOR ENVIRONMENTAL, INC.

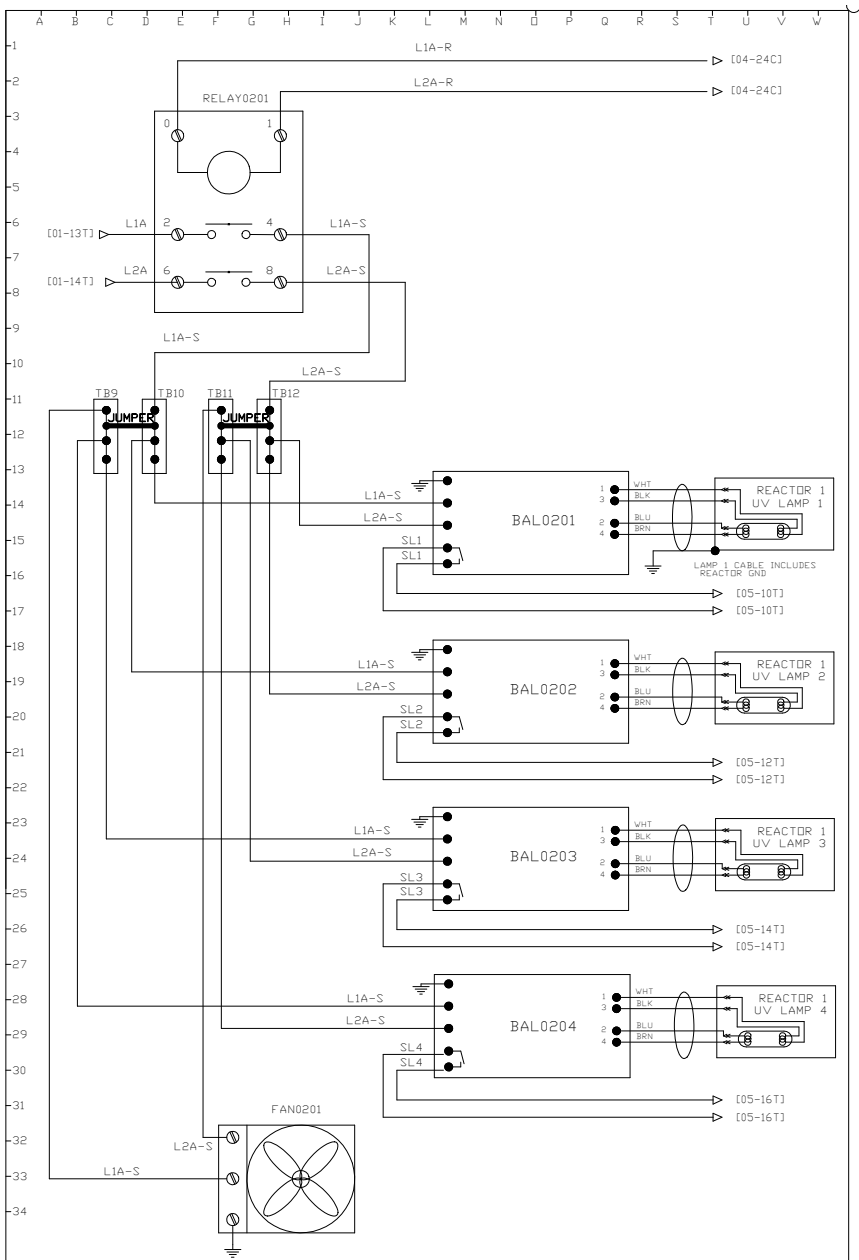

B	UPDATE LABELS AND REFLECT AS-BUILT	TEB	2023-08-29
A	INITIAL RELEASE	TEB	2023-07-13
REV.	REV. DESCRIPTION	REV. BY	DATE
DESCRIPTION CONTROL PANEL, EVEREST, 6-LAMP SCHEMATIC			
PROJECT:	DRAWING NO. LEX-A62	SHEET: 02	REV: B



COPYRIGHT © 2023 BY LUMINOR ENVIRONMENTAL INC. QUEBEC, QUEBEC, CANADA. ALL RIGHTS RESERVED. NO PART OF THIS DOCUMENT MAY BE REPRODUCED, STORED IN A RETRIEVAL SYSTEM, OR TRANSMITTED IN ANY FORM, WITHOUT THE WRITTEN PERMISSION OF LUMINOR ENVIRONMENTAL INC.

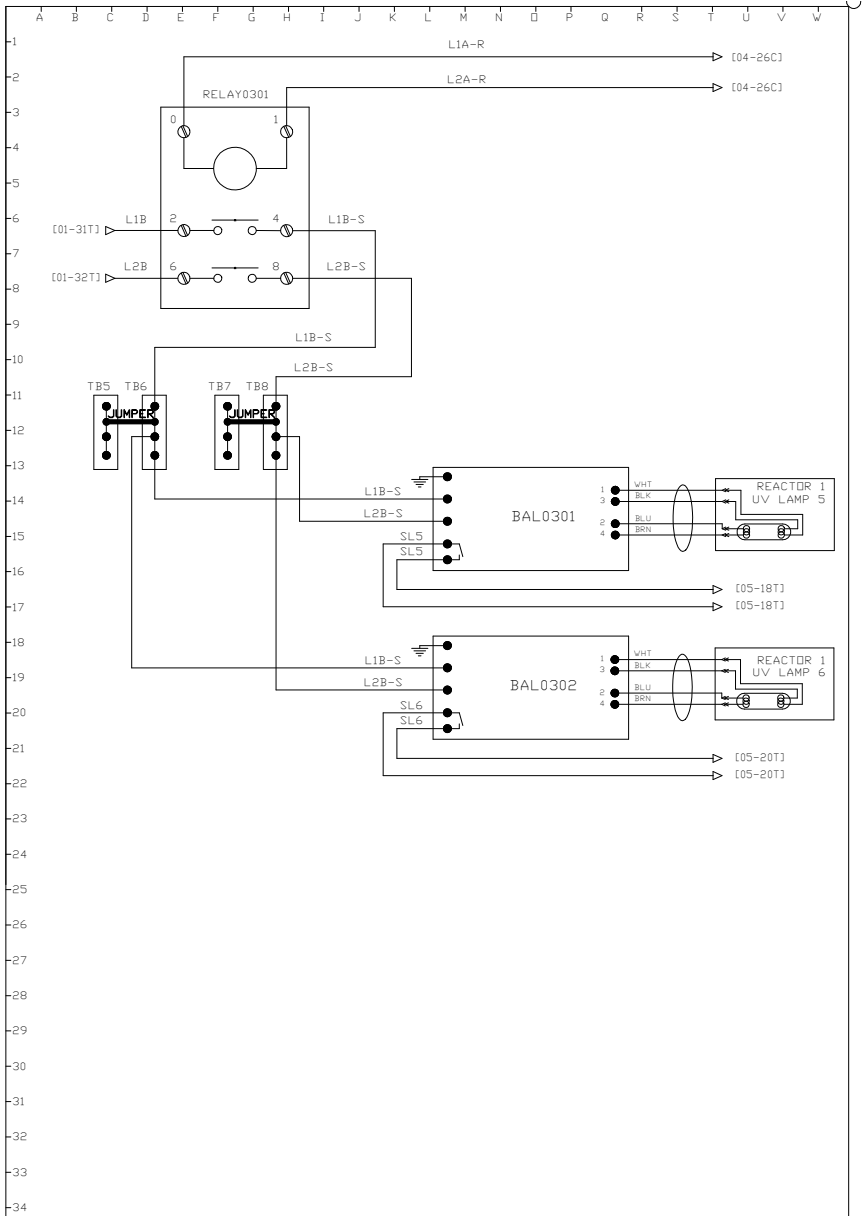

B	UPDATE LABELS AND REFLECT AS-BUILT	TEB	2023-08-29
A	INITIAL RELEASE	TEB	2023-07-13
REV.	REV. DESCRIPTION	REV. BY	DATE
DESCRIPTION CONTROL PANEL, EVEREST, 6-LAMP SCHEMATIC			
PROJECT:	DRAWING NO.	SHEET	REV.
	LEX-A62	03	B



COPYRIGHT © 2023 BY LUMINOR ENVIRONMENTAL INC. QUEBEC, QUEBEC, CANADA. ALL RIGHTS RESERVED. NO PART OF THIS DOCUMENT MAY BE REPRODUCED, STORED IN A RETRIEVAL SYSTEM, OR TRANSMITTED IN ANY FORM, WITHOUT THE WRITTEN PERMISSION OF LUMINOR ENVIRONMENTAL INC.

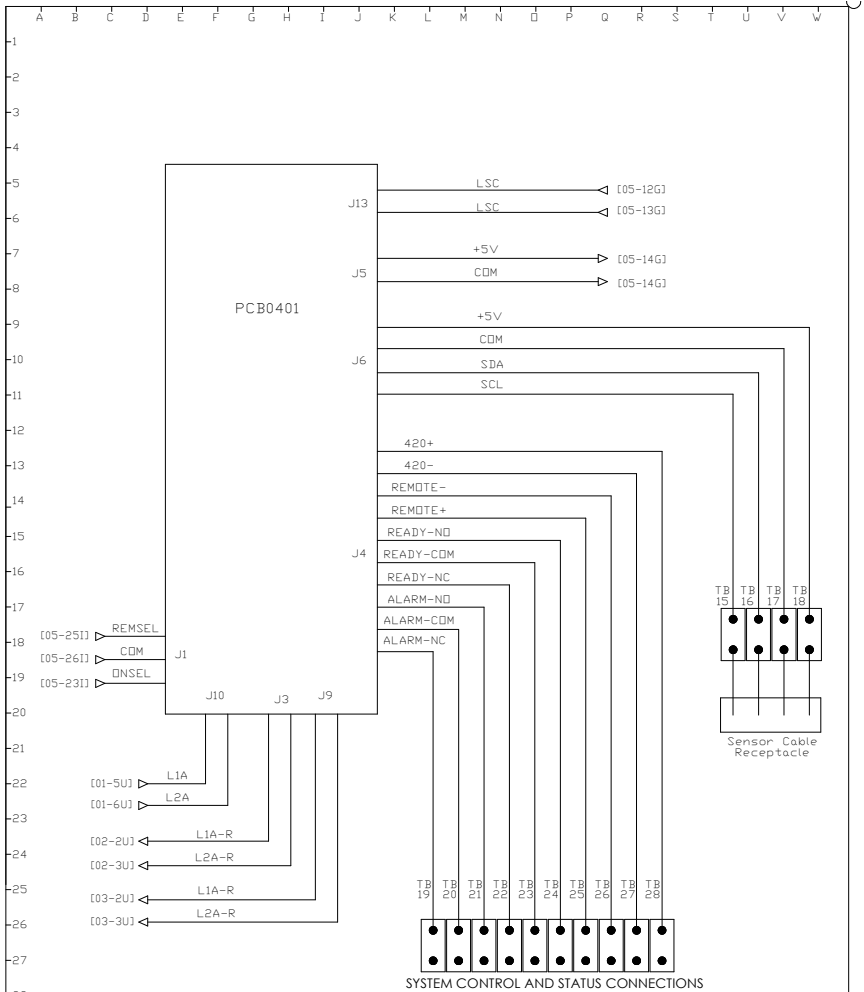

SYSTEM CONTROL AND STATUS CONNECTIONS - TECHNICAL INFORMATION

Relevant Pins	Parameter	Value
ALARM-NC, ALARM-NO, ALARM-COM, READY-NC, READY-NO, READY-COM	Max Rated Current	2.5A
	Max Contact Resistance	100 ma
	Contact Insulation	750V
	Typical Coil Voltage	24 VDC
REMOTE+, REMOTE-	Max Coil Current	16 mA
	Coil Insulation	750 VAC
	Loop Voltage	8-24 VDC
420+, 420-	Nominal Transduced Current Range	4-20 mA
	Current Tolerance	15%

B	UPDATE LABELS AND REFLECT AS-BUILT	TEB	2023-08-29
A	INITIAL RELEASE	TEB	2023-07-13
REV.	REV. DESCRIPTION	REV. BY	DATE
DESCRIPTION CONTROL PANEL, EVEREST, 6-LAMP SCHEMATIC			
PROJECT:	DRAWING NO. LEX-A62	SHEET 04	REV. B



COPYRIGHT © 2023 BY LUMINOR ENVIRONMENTAL INC. QUEBEC, QUEBEC, CANADA. ALL RIGHTS RESERVED. NO PART OF THIS DOCUMENT MAY BE REPRODUCED, STORED IN A RETRIEVAL SYSTEM, OR TRANSMITTED IN ANY FORM, WITHOUT THE WRITTEN PERMISSION OF LUMINOR ENVIRONMENTAL INC.

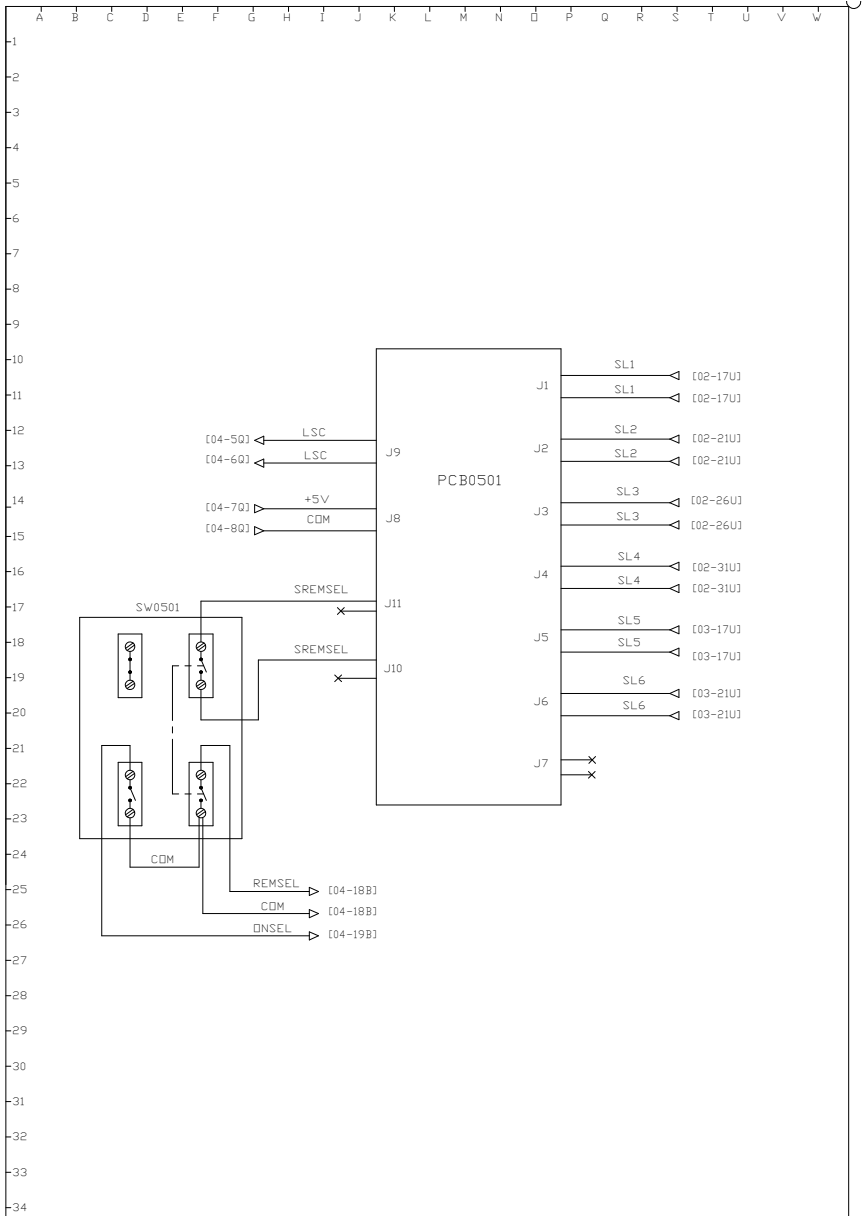

B	UPDATE LABELS AND REFLECT AS-BUILT	TEB	2023-08-29
A	INITIAL RELEASE	TEB	2023-07-13
REV.	REV. DESCRIPTION	REV. BY	DATE
DESCRIPTION CONTROL PANEL, EVEREST, 6-LAMP SCHEMATIC			
PROJECT:	DRAWING NO. LEX-A62	SHEET 05	REV. B



COPYRIGHT © BY LUMINOR ENVIRONMENTAL INC. QUEBEC, QUEBEC, CANADA. ALL RIGHTS RESERVED. NO PART OF THIS DOCUMENT MAY BE REPRODUCED, STORED IN A RETRIEVAL SYSTEM, OR TRANSMITTED IN ANY FORM, WITHOUT THE WRITTEN PERMISSION OF LUMINOR ENVIRONMENTAL INC.

Electrical Schematics for LEX-A72

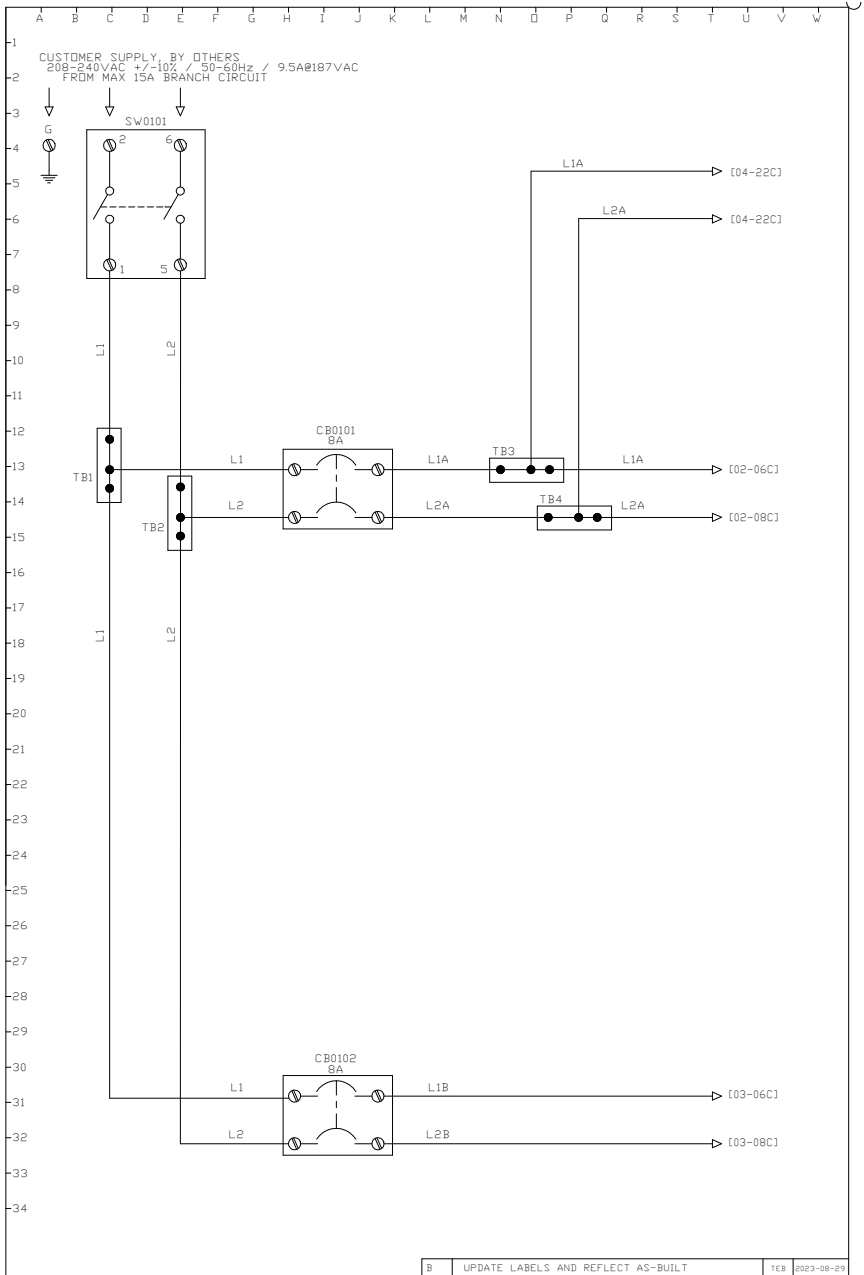

B	UPDATE LABELS AND REFLECT AS-BUILT	TEB	2023-08-29
A	RELEASED FOR PRODUCTION	TEB	2023-08-09
REV.	REV. DESCRIPTION	REV. BY	DATE
DESCRIPTION CONTROL PANEL, EVEREST, 7-LAMP SCHEMATIC			
PROJECT	DRAWING NO. LEX-A72	SHEET 01	REV. B



COPYRIGHT © 2023 BY LUMINOR ENVIRONMENTAL, INC. GUELPH, ONTARIO, CANADA. ALL RIGHTS RESERVED. NO PART OF THIS DOCUMENT MAY BE REPRODUCED, STORED IN A RETRIEVAL SYSTEM, OR TRANSMITTED IN ANY FORM, WITHOUT THE WRITTEN PERMISSION OF LUMINOR ENVIRONMENTAL, INC.

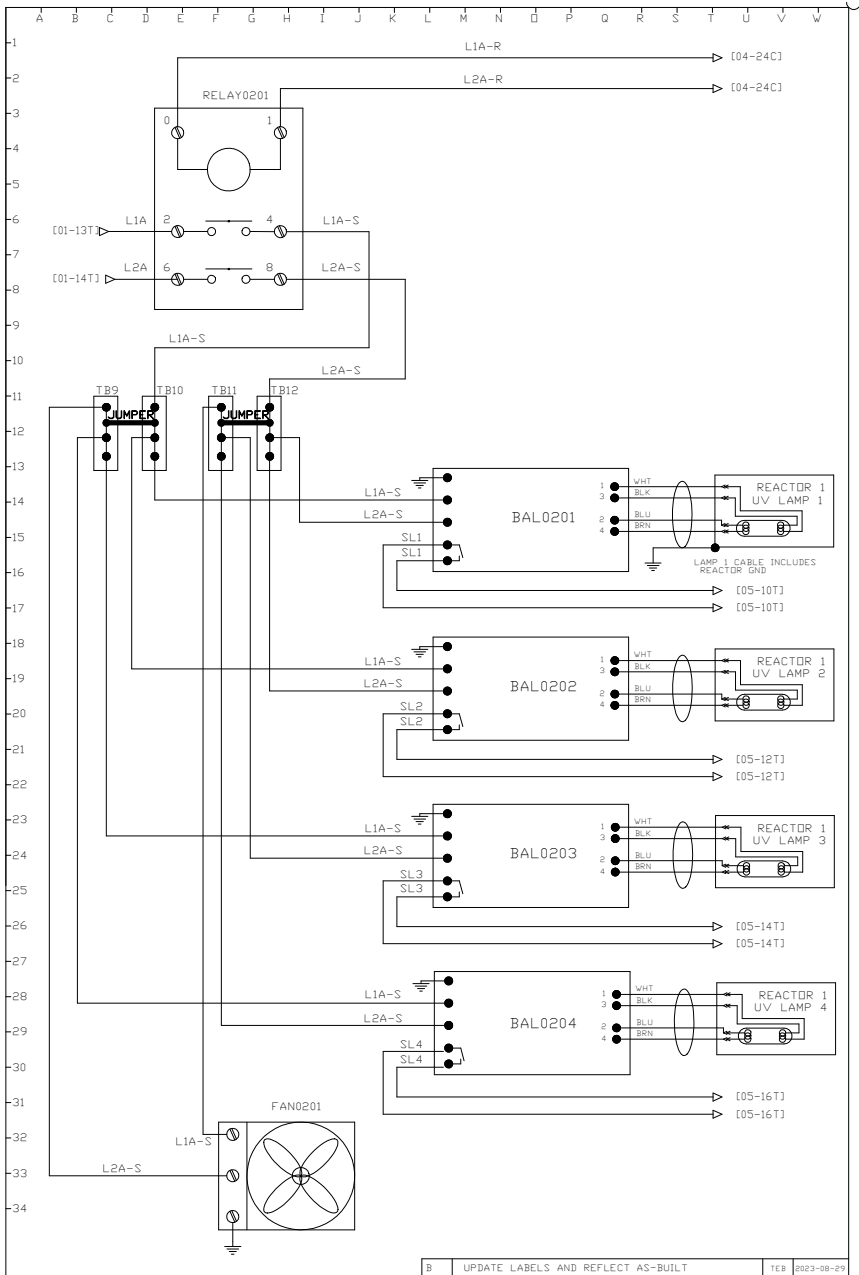

B	UPDATE LABELS AND REFLECT AS-BUILT	TEB	2023-08-29
A	RELEASED FOR PRODUCTION	TEB	2023-08-09
REV.	REV. DESCRIPTION	REV.	BY DATE
DESCRIPTION CONTROL PANEL, EVEREST, 7-LAMP SCHEMATIC			
PROJECT:	DRAWING NO. LEX-A72	SHEET 02	REV. B



COPYRIGHT © 2023 BY LUMINOR ENVIRONMENTAL INC. QUEBEC, QUEBEC, CANADA. ALL RIGHTS RESERVED. NO PART OF THIS DOCUMENT MAY BE REPRODUCED, STORED IN A RETRIEVAL SYSTEM, OR TRANSMITTED IN ANY FORM, WITHOUT THE WRITTEN PERMISSION OF LUMINOR ENVIRONMENTAL INC.

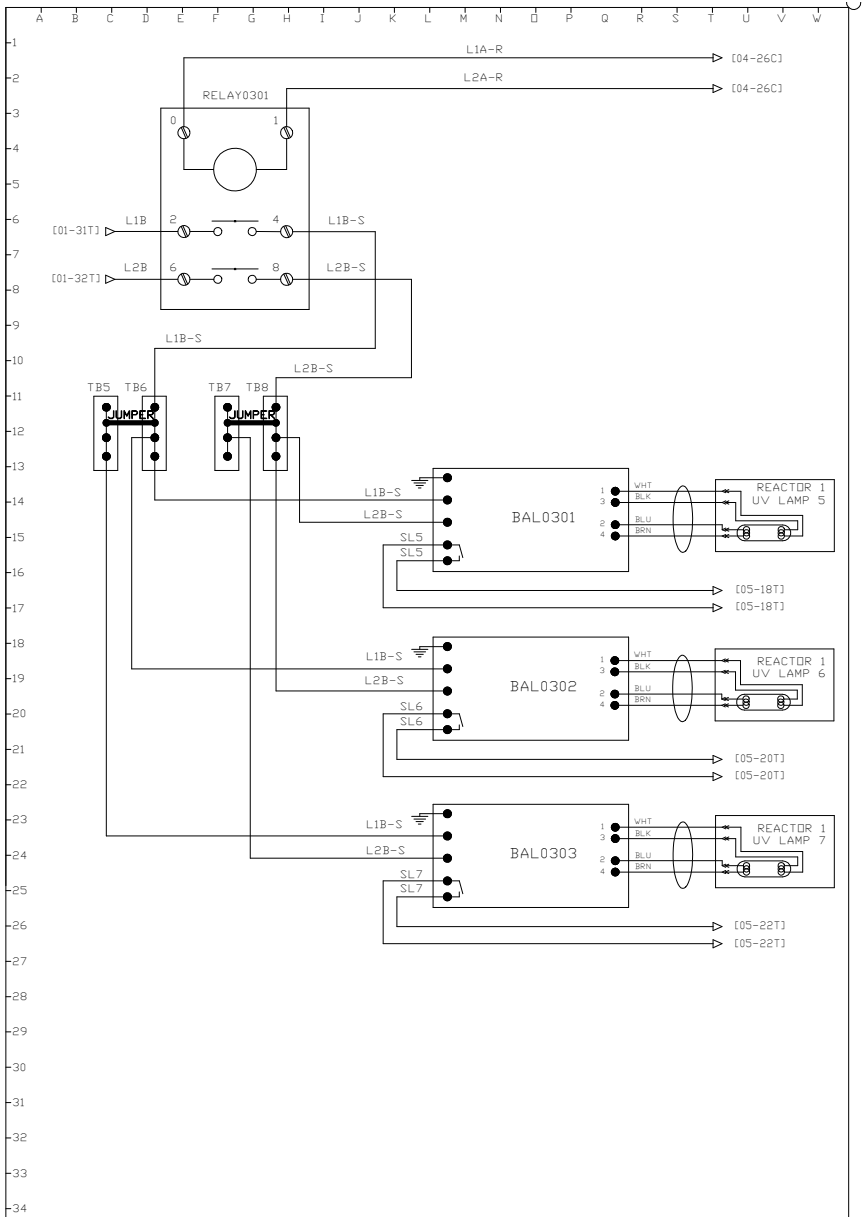

B	UPDATE LABELS AND REFLECT AS-BUILT	TEB	2023-08-29
A	RELEASED FOR PRODUCTION	TEB	2023-08-09
REV.	REV. DESCRIPTION	REV. BY	DATE
DESCRIPTION CONTROL PANEL, EVEREST, 7-LAMP SCHEMATIC			
PROJECT:	DRAWING NO. LEX-A72	SHEET 03	REV. B



COPYRIGHT © 2023 BY LUMINOR ENVIRONMENTAL INC. QUEBEC, QUEBEC, CANADA. ALL RIGHTS RESERVED. NO PART OF THIS DOCUMENT MAY BE REPRODUCED, STORED IN A RETRIEVAL SYSTEM, OR TRANSMITTED IN ANY FORM, WITHOUT THE WRITTEN PERMISSION OF LUMINOR ENVIRONMENTAL INC.

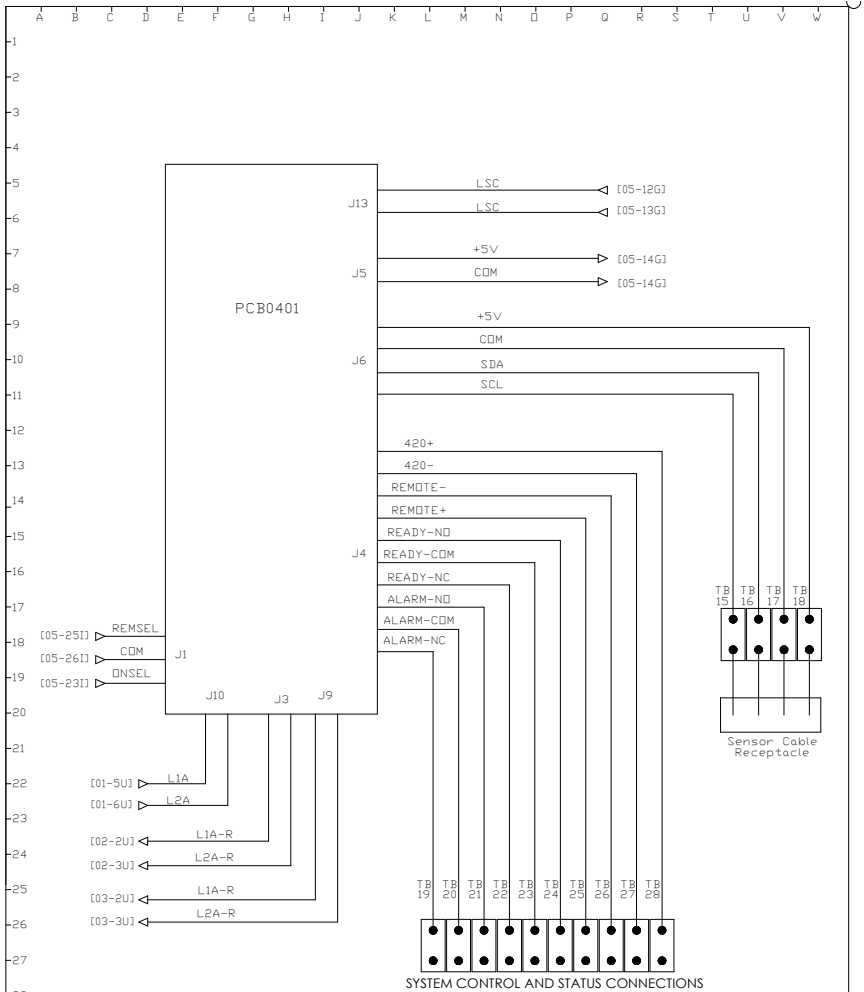

SYSTEM CONTROL AND STATUS CONNECTIONS - TECHNICAL INFORMATION

Relevant Pins	Parameter	Value
ALARM-NC, ALARM-NO, ALARM-COM, READY-NC, READY-NO, READY-COM	Max Rated Current	2.5A
	Max Contact Resistance	100 ma
	Contact Insulation	750V
	Typical Coil Voltage	24 VDC
REMOTE+, REMOTE-	Max Coil Current	16 mA
	Coil Insulation	750 VAC
	Loop Voltage	8-24 VDC
420+, 420-	Nominal Transduced Current Range	4-20 mA
	Current Tolerance	15%

B	UPDATE LABELS AND REFLECT AS-BUILT	TEB	2023-08-29
A	RELEASED FOR PRODUCTION	TEB	2023-08-09
REV.	REV. DESCRIPTION	REV. BY	DATE
DESCRIPTION CONTROL PANEL, EVEREST, 7-LAMP SCHEMATIC			
PROJECT:	DRAWING NO. LEX-A72	SHEET 04	REV. B



COPYRIGHT © 2023 BY LUMINOR ENVIRONMENTAL, INC. QUEBEC, QUEBEC, CANADA. ALL RIGHTS RESERVED. NO PART OF THIS DOCUMENT MAY BE REPRODUCED, STORED IN A RETRIEVAL SYSTEM, OR TRANSMITTED IN ANY FORM, WITHOUT THE WRITTEN PERMISSION OF LUMINOR ENVIRONMENTAL, INC.

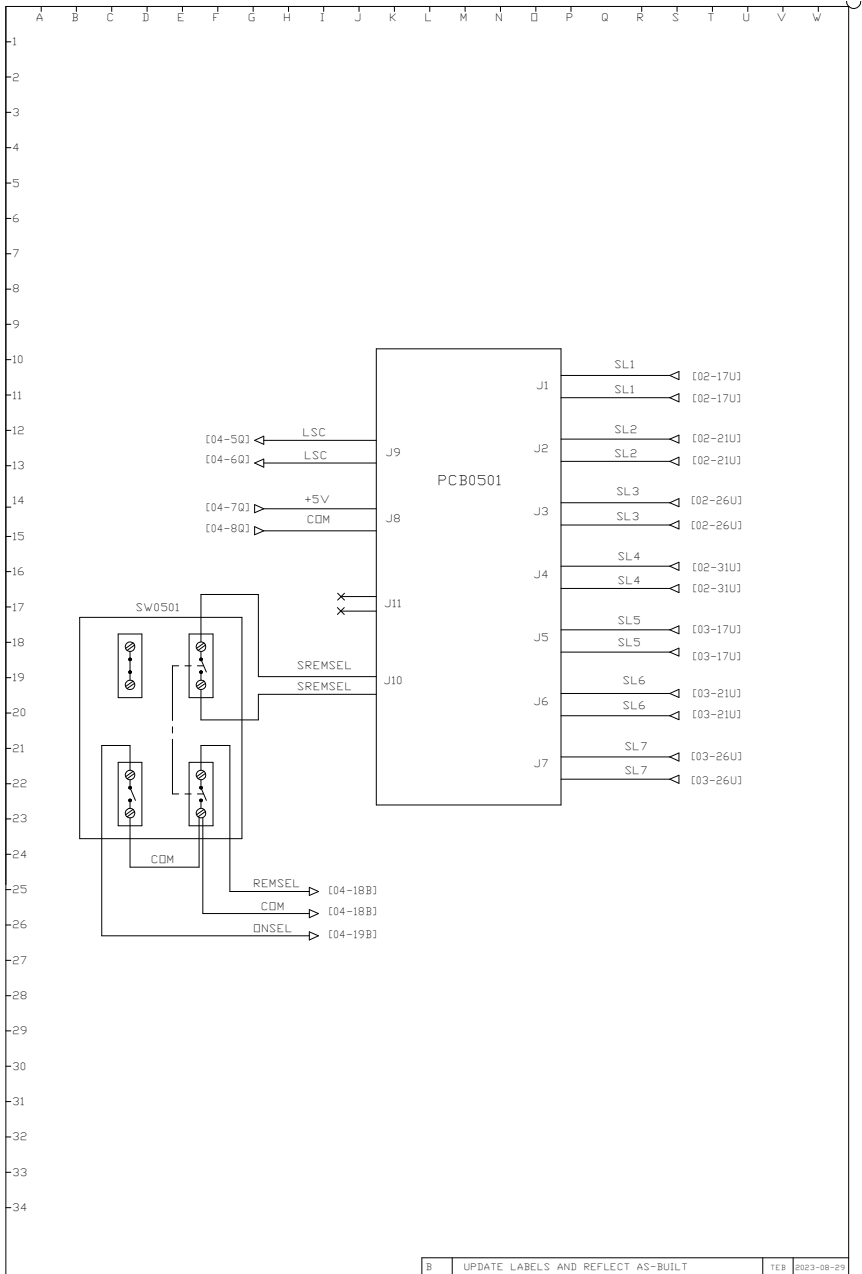

B	UPDATE LABELS AND REFLECT AS-BUILT	TEB	2023-08-29
A	RELEASED FOR PRODUCTION	TEB	2023-08-09
REV.	REV. DESCRIPTION	REV BY	DATE
DESCRIPTION CONTROL PANEL, EVEREST, 7-LAMP SCHEMATIC			
PROJECT:	DRAWING NO.	SHEET	REV.
	LEX-A72	05	B



COPYRIGHT © BY LUMINOR ENVIRONMENTAL INC. QUEBEC, QUEBEC, CANADA. ALL RIGHTS RESERVED. NO PART OF THIS DOCUMENT MAY BE REPRODUCED, STORED IN A RETRIEVAL SYSTEM OR TRANSMITTED IN ANY FORM, WITHOUT THE WRITTEN PERMISSION OF LUMINOR ENVIRONMENTAL INC.



LUMINOR Environmental Inc.

80 Southgate Drive, Unit 4, Guelph, Ontario, CANADA N1G 4P5
Phone: (519) 837-3800 | Toll Free: (855) 837-3801 | Fax: (519) 837-3808
info@luminoruv.com
www.luminoruv.com



LUMINOR Environmental



LuminorUV



LuminorUV



EPA Establishment
#088776-CAN-001

PN: 919386
Rev E / 04-24