

***Model 2850***  
***1.5" Top Mount Valve***  
***Filtration Unit***

**Cambridge, Ontario, Canada**

-

**Fridley, Minnesota, USA**

-

**Regina, Saskatchewan, Canada**

-

**Sun Valley, California, USA**

**Read manual thoroughly before proceeding with installation**

Jan 2005  
#459915

---

Customer \_\_\_\_\_  
 Project No. \_\_\_\_\_  
 Unit Serial No. \_\_\_\_\_  
 Valve Serial No. \_\_\_\_\_  
 Assembly Date \_\_\_\_\_  
 Assembled By: \_\_\_\_\_

**Model** \_\_\_\_\_ - \_\_\_\_\_ - \_\_\_\_\_ - \_\_\_\_\_ - \_\_\_\_\_

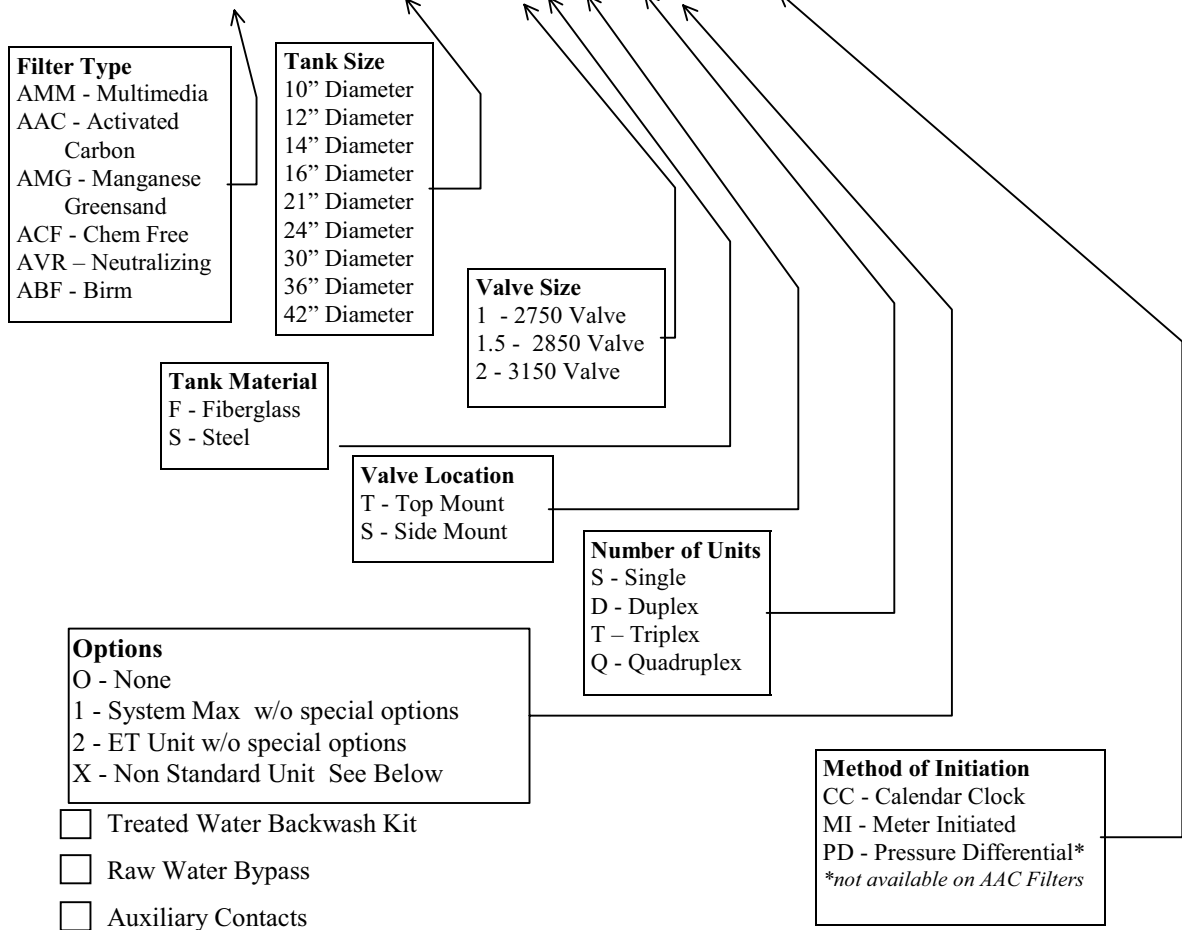

**Options**  
 O - None  
 1 - System Max w/o special options  
 2 - ET Unit w/o special options  
 X - Non Standard Unit See Below

- Treated Water Backwash Kit
  - Raw Water Bypass
  - Auxiliary Contacts
- Description \_\_\_\_\_

- System Max 2000 Programmable Controller (Also see system max manual)
- ET Digital Controller (Also see ET manual)
- Environmental Enclosure
- Side Mounted Valve (2850, 3130, 3150 Valve Only)
- Special Media Loading  
 (See Section 5.2 for Media Loading Details)
- 220 VAC/50Hz Power Supply  
 (115 VAC/60Hz standard)  
 Other, (specify). \_\_\_\_\_
- Other, (Specify). \_\_\_\_\_

## Table Of Contents

---

---

### Section 1 Product Summary

- 1.1 Product Summary

### Section 2 General Specifications

- 2.1 Operating Parameters
- 2.2 Tanks
- 2.3 Standard Distribution
- 2.4 Control Valve
- 2.5 Performance
  - .1 Multimedia
  - .2 Manganese Greensand
  - .3 Activated Carbon
  - .4 Chemical Free
  - .5 Neutralizing
  - .6 Birm
- 2.6 Standard Pin Settings

### Section 3 Inspection

- 3.1 General Inspection

### Section 4 Installation

- 4.1 Tank Positioning
- 4.2 Media Installation
  - .1 Potassium Permanganate Soak (Manganese Greensand Only)
- 4.3 Piping
  - .1 Injection Pump (Manganese Greensand Only)
  - .2 Hydrocharger (Chem Free Only)
  - .3 Treated Water Regeneration
- 4.4 Electrical
  - .1 Standard Mechanical And ET
  - .2 Systemax
  - .3 Wiring Termination
  - .4 Valve Wiring Drawings E-1164A

### Section 5 Media Specifications

- 5.1 Media Description
- 5.2 Media Bed Quantities
  - .1 Special Media
  - .2 Multi Media
  - .3 Manganese Greensand
  - .4 Activated Carbon
  - .5 Neutralizing
  - .6 Chemical Free
  - .7 Birm

### Section 6 Filter Parts Breakdown

- 6.1 Control Drive Assembly
- 6.2 Valve Timer Assembly
- 6.3 Valve Body (Raw Water Bypass Shown)
  - .1 No Raw Water Bypass Piston Assembly
- 6.5 Service Valve Operator (SVO)
- 6.6 Meter Assembly
- 6.7 Remote Meter Immediate Timer
  - .1 Remote Meter Delayed Timer

### Section 7 Start Up

- 7.1 Filter Start Up
- 7.2 Chemical Pump Start Up (Manganese Greensand Only)
- 7.3 Hydro-charger Set (Chemical Free Only)

### Section 8 Operation

- 8.1 Operating Conditions
- 8.2 Cycle Operation
  - .1 Service
  - .2 Backwash
  - .3 Settle Position
  - .4 Rinse

### Section 9 Control

- 9.1 Calendar Clock
- 9.2 Meter
- 9.3 Pressure Differential
- 9.4 Regeneration Cycle Timer
- 9.5 Regeneration Program
- 9.6 Changing the Regeneration Cycle Times

### Section 10 Troubleshooting

- 10.1 Troubleshooting
- 10.2 Seal & Spacer and Piston Replacement

### Appendix A

- Pressure Vessel Lifting, Handling & Installation Instructions

### Section 11 Warranty

## **Section 1. Product Summary**

---

### **Commercial Pressure Filtration**

---

You have just acquired a WaterGroup Companies Inc. / WaterGroup Inc. commercial filtration system. Your filter system may be one of five different series of filtration products, each designed for a specific application.

#### ***AAC Series - Activated Carbon Filter***

Water containing dissolved or suspended organic material will exhibit tastes, odours and colours which are offensive to potable water users, and troublesome to processes such as those in the food and beverage industry. Excess chlorine can also cause taste and odour problems.

WaterGroup Companies Inc. / WaterGroup Inc. activated carbon filters are specially designed to ensure that the water passes down through the filter bed evenly and with sufficient contact time to allow for the effective adsorption of impurities.

#### ***AMM Series - Multi-Media Filter***

Multi-media filters effectively remove suspended matter, turbidity, dirt, and rust particles from water in the range of 15-20 microns. Three layers of filter media, anthracite, filter sand, and garnet enable the multimedia filter to perform superb depth filtration. In addition, this method of filtration permits higher flowrates and longer service runs.

#### ***AVR Series - Neutralizing Filters***

Every year, hotels, apartments, schools, industry, and hospitals spend millions of dollars on replacement of corroded copper piping and components because of low pH water supply. WaterGroup Companies Inc. / WaterGroup Inc. neutralising filters effectively and safely adjust the pH of this aggressive water without the use of chemicals. The result is conditioned water which reduces the corrosion and failure of copper water lines and eliminates any high turbidity levels that may occur in the water supply.

#### ***ACF Series - Chemical Free Iron Filter***

The presence of iron in concentrations as low as 0.3 ppm can cause staining and sludge formation. WaterGroup Companies Inc. / WaterGroup Inc. chemical free iron filters remove iron and dissolved hydrogen sulphide gas from water without the use of chemical oxidants.

#### ***ABF Series – Birm Filter***

Iron in concentrations as low as 0.3 ppm respectively can cause staining and sludge formation. WaterGroup Companies Inc. / WaterGroup Inc. birm filter removes iron without the use of chemicals

#### ***AMG Series - Manganese Greensand Filter***

Iron and manganese in concentrations as low as 0.3 ppm and 0.05 ppm respectively can cause staining and sludge formation. Hydrogen sulphide gas dissolved in water causes an offensive odour in concentrations as low as 1.0 ppm.

WaterGroup Companies Inc. / WaterGroup Inc manganese greensand filters remove iron, manganese and hydrogen sulphide using an oxidation and filtration process. Oxidation of the objectionable elements is accomplished by injecting a potassium permanganate solution into the water, upstream of the filters. Filtration media consists of a layer of anthrafil on top of the manganese greensand bed.



## Section 2. 2850 Valve Filters - General Specifications

### 2.5.2 Manganese Greensand Filters

Model Number	Max Service Flowrate*			Backwash Flowrate	Tank Size	Unit Weight
	0-3 ppm	3-8 ppm	8-15 ppm			
AMG 21	12 USGPM	7 USGPM	5 USGPM	25 USGPM	21" x 69"	820 lbs
AMG 24	16 USGPM	9 USGPM	6 USGPM	30 USGPM	24" x 71"	1075 lbs

\* Service flowrates given above are based upon a total equivalent iron level.

Total equivalent iron = Fe + 2Mn

where Fe = Iron Level, (ppm)

Mn = Manganese Level, (ppm)

The above flowrates are generalizations only, based upon average water qualities.

### 2.5.3 Activated Carbon Filters

Model Number	Max Service* Flowrate	RO Pretreat Flowrate	Backwash Flowrate	Tank Size	Unit Weight
AAC 21	14 USGPM	6 USGPM	25 USGPM	21" x 69"	440 lbs
AAC 24	19 USGPM	8 USGPM	30 USGPM	24" x 71"	560 lbs

\*Above service flowrates should be reduced in applications with excessively high organic or chlorine levels.

Contact your equipment supplier for more information.

### 2.5.4 Chemical Free Filters

Model Number	Service* Flowrate	Peak Flowrate	Backwash Flowrate	Tank Size	Unit Weight
ACF 21	7 USGPM	12 USGPM	25 USGPM	21" x 69"	830 lbs
ACF 24	9 USGPM	16 USGPM	30 USGPM	24" x 71"	1075 lbs

\*Above service flowrates flowrate should be reduced in applications with excessively high levels

Peak flowrates only valid for short periods of time (less than 5 minutes) depending upon water conditions

### 2.5.5 Neutralizing Filters

Model Number	Service Flowrate	Peak Flowrate	Backwash Flowrate	Tank Size	Unit Weight
AVR 21	12 USGPM	25 USGPM	30 USGPM	21" x 69"	880 lbs
AVR 24	15 USGPM	33 USGPM	40 USGPM	24" x 71"	1145 lbs

Peak flowrates only valid for short periods of time (less than 5 minutes) depending upon water conditions

**Section 2. 2850 Valve Filters - General Specifications**

**2.5.6 Birm Filters**

Model Number	Max Service Flowrate	Backwash Flowrate	Tank Size	Unit Weight
ABF 21	12 USGPM	25 USGPM	21" x 69"	830 lbs
ABF 24	15 USGPM	30 USGPM	24" x 71"	1075 lbs

\* Above service flowrates should be reduced in applications with excessively high levels.

**2.6 Regeneration Pin Settings**

Pin settings for the Multi-media (AMM), Manganese Greensand (AMG), Activated Carbon (AAC), and Neutralizing (AVR) are 12 minutes backwash, 2 minutes first settle, 6 minutes fast rinse, 2 minutes second settle, home. See figure 2.1 below. The first three pins extend to depress the inside switch, which initiate the next unit.

Pin settings for the Chem-Free (ACF) are 6 minutes backwash, 2 minutes first settle, 6 minutes fast rinse, 2 minutes second settle, home. See figure 2.2 below. The first three pins extend to depress the inside switch, which initiate the next unit.

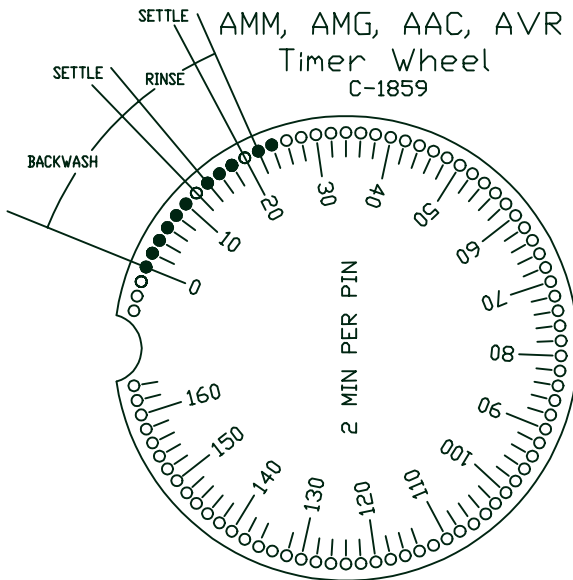

Fig 2.1 Pin settings for AMM, AMG, AAC, AVR

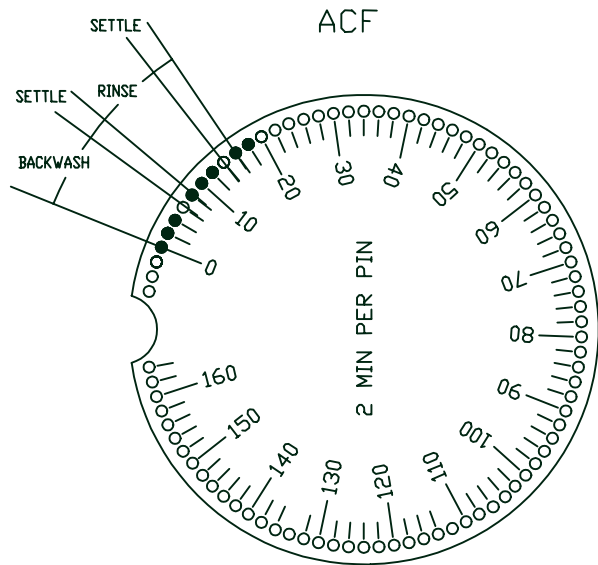

Fig 2.2 Pin settings for ACF, ABF

## Section 3. Inspection

---

### 3.1 General

---

- Check the product summary to determine what options you have received, (See section 1 for any options you may have received).
- If you have not received the items that are required for assembly of the filter, please contact your supplier.
- Inspect the equipment, (including internal distribution), for any visible shipping damage. If damaged, notify the transportation company and request a damage inspection. Damage to cartons should also be noted.
- **Read manual thoroughly before proceeding with installation.**
- Handle filter unit with care. Damage can result if dropped or set on sharp, uneven projections on the floor.
- Each filter you have received consists of the following items:
  - Control valve.
    - includes assembled valve, and backwash flow control
  - Fiberglass tank, complete with internal distribution
  - Filter media bed
- Other items that may accompany your filter are:
  - Volumetric meter, (meter initiated units only)
  - Hydrocharger Bank & Braukman air release (chem free units only)
  - PD switch, (pressure differential initiated units only)  
*Note: PD switch option not available with activated carbon filters.*
  - Treated water backwash kit.
    - comes with diaphragm valves and fittings required for installation of kit.
    - Note: Used only for treated water backwash configuration, (see Fig 4.6)*
  - Systemax 2000 Programmable Controller.
    - comes with interconnecting cables, and operation manual.
  - Potassium permanganate chemical injection pump c/w solution tank  
*Note: Potassium permanganate chemical injection pump only supplied with manganese greensand filters.*
  - Contacting flowmeter, (manganese greensand filters only):  
*Note: Used only in applications where a manganese greensand filter is required, and the service flowrate varies. The chemical pump is different than the standard pump normally supplied and must be ordered separately from filter unit with the contacting meter.*

## Section 4. Installation

---

### 4.1 Tank Positioning

---

- Position the tanks as shown on the installation drawing, (see Fig. 4.1 for drawing)  
*Note: The tanks should be located on a level support pad, with adequate access space on all sides, (all units in duplex and/or triplex systems must be within 3 feet of one another for the interconnect cable to properly attach).*
- Check hub and laterals in the tank for any damage that may have occurred during transport.
- Thread the control valve snugly into the tank using silicone grease on o-rings, and adjust filter position until the desired orientation is achieved.  
*Note: Do not move tank after this is completed, because once the filter media is installed, the filter will be very difficult to move, and damage may occur if the tank is moved when filled with media.*

### 4.2 Media Installation

---

Note: Before installing chem-free media, ensure that the filter will be backwashed shortly after media installation (typically 3 to 4 hours depending upon site conditions). It is not recommended to have a loaded chem-free filter remain stagnant for an extended period of time between media loading and filter start-up. If this is not followed, or if the chem free filter is drained down after filling with water, the bed can "cement".

- Remove the valve from the filter tank.
- Temporarily plug the open end of the riser tube to ensure that no media falls down into the distribution.



- Fill filter tank one quarter full of water to protect distribution during media installation. Do not add water for the chem free units.
- Slowly and carefully add the filter media as outlined in Section 5, Media Specifications.  
*Note: Be sure to level each layer as it is placed into the filter tank.*
- Unplug the riser tube, carefully position the valve over it and turn valve into threads in fiberglass tank, tightening securely into tank to ensure the tank has not moved.  
*Note: Ensure that the internal O-ring in the valve fits securely over the riser tube. Silicone grease or other food grade lubricant, should be applied to the O-ring to ease installation of the riser tube.*
- The filter is now charged with media.
- With all filters except the chem free filters, it is recommended that the filter tank be completely filled with water to soak the media. This will allow the media to absorb water as well as displace any air trapped and will help reduce the chance of backwashing media out during startup. *Note: For greensand filters, follow section 4.2.1*

#### 4.2.1 Potassium Permanganate Soak, (manganese greensand filters only)

When the media installation has been completed and the piping is to begin, it is recommended to pretreat manganese greensand with a saturated potassium permanganate solution to ensure it is in peak condition to give the best operating results:

- Dissolve approx. 4 ounces of potassium permanganate per cu. ft. of greensand in a container of water. A recommended solution strength for the treatment soak is 4 ounces of potassium permanganate per 1 US gallon of dilution water. Check section 5, “Media Specifications”, for the quantity of greensand in each filter size.  
*Note: It is important that the potassium permanganate be totally dissolved in water before being added to the filter.*
- Pour the potassium permanganate solution into the tank on top of the media.
- Begin filling the tank with clear water until the water level in the tank is approximately 3 inches above the level of the media. This should be done by simply hand filling the tank with either a hose, or a pail.
- Thread the control valve back on top of the tank into its permanent position.
- Once the valve is connected, the installation can be continued by beginning the piping required for filter installation.
- Allow the filter to stand for a minimum of 3 hours. Ideally, it is recommended the filter be left to soak until the filter is to be placed into service or at least overnight if possible.  
*Note: It is imperative that the manual isolation valve on the filter outlet be fully closed for the duration of the soaking process. Once the soaking process is complete, remember to fully backwash the media bed until the effluent running to the drain runs clear. It is critical that the filter be properly backwashed during start-up. Inadequate backwash of the filter may result in inferior operation of the filter during service.*

#### 4.3 Piping

---

- Install the piping conforming to federal, provincial and local codes. Unions and/or flanges are recommended and isolation and by-pass valves should also be installed. Flex connectors should be used on the inlet and outlet piping to allow for slight expansion and contraction of the fiberglass tank during operation under system pressure. An alternative to flex connectors is the inherent flexibility of right angle system design shown on page 23 of the “Pressure Vessel Lifting, Handling & Installation Instructions” manual in appendix A. **For proper system operation and startup, and to monitor the softener’s removal capacity and efficiency, sample points and pressure gauges must be installed on each unit immediately before (on the inlet piping) and after (on the outlet piping) each softener. See Fig. 4.1 for a typical installation.** Putting fiberglass tanks into a vacuum condition will void the tank warranty. If a vacuum condition could ever occur, the tank must be protected by use of a vacuum breaker to ensure the tank does not experience a vacuum condition, see page 22 of the “Pressure Vessel Lifting, Handling & Installation Instructions” manual in appendix A.
- The drain line should be as short as possible and must be piped to an open drain. Access to the drain and an air gap are necessary for visual inspection and testing of drain water. The floor drain must be sized to carry the maximum listed flow to drain. (See section 2 for flowrates) It is recommended that the drain pipe size should be at least the same size of pipe or larger as the inlet and outlet piping. (See section 2.4)
- Install the backwash flow control in the drain line piping. The arrow stamped on the side of the control indicates the direction of flow (to drain). The backwash flow rate is controlled by a flow control that is factory set, and does not require adjustment on site. This flowrate may be checked by timing and measuring the flow through to the drain.
- If the filtered water exiting the filters is flowing into an open reservoir, it is recommended that a loop in the piping be installed in the system outlet to prevent the filters from draining down which can lead to operational problems. The loop must extend above the top of the filter tanks with a vacuum breaker at the high point of the loop, and then drops

into the reservoir include an air gap to help prevent siphoning. This is especially critical with chemical free filters, where draining the tank for any extended period of time can cause the media to solidify. *Often solidified media cannot be removed, and will require complete replacement of the tank, distribution, and media to return the unit to service.* The filters have the best service performance if there is some backpressure on the system (eg. 30 psi). This could be achieved by partially closing a *system* outlet valve or putting on flow controllers into the outlet piping.

- Any piping before and after the filter(s) must be properly supported, to prevent any stress on the filter by the piping.

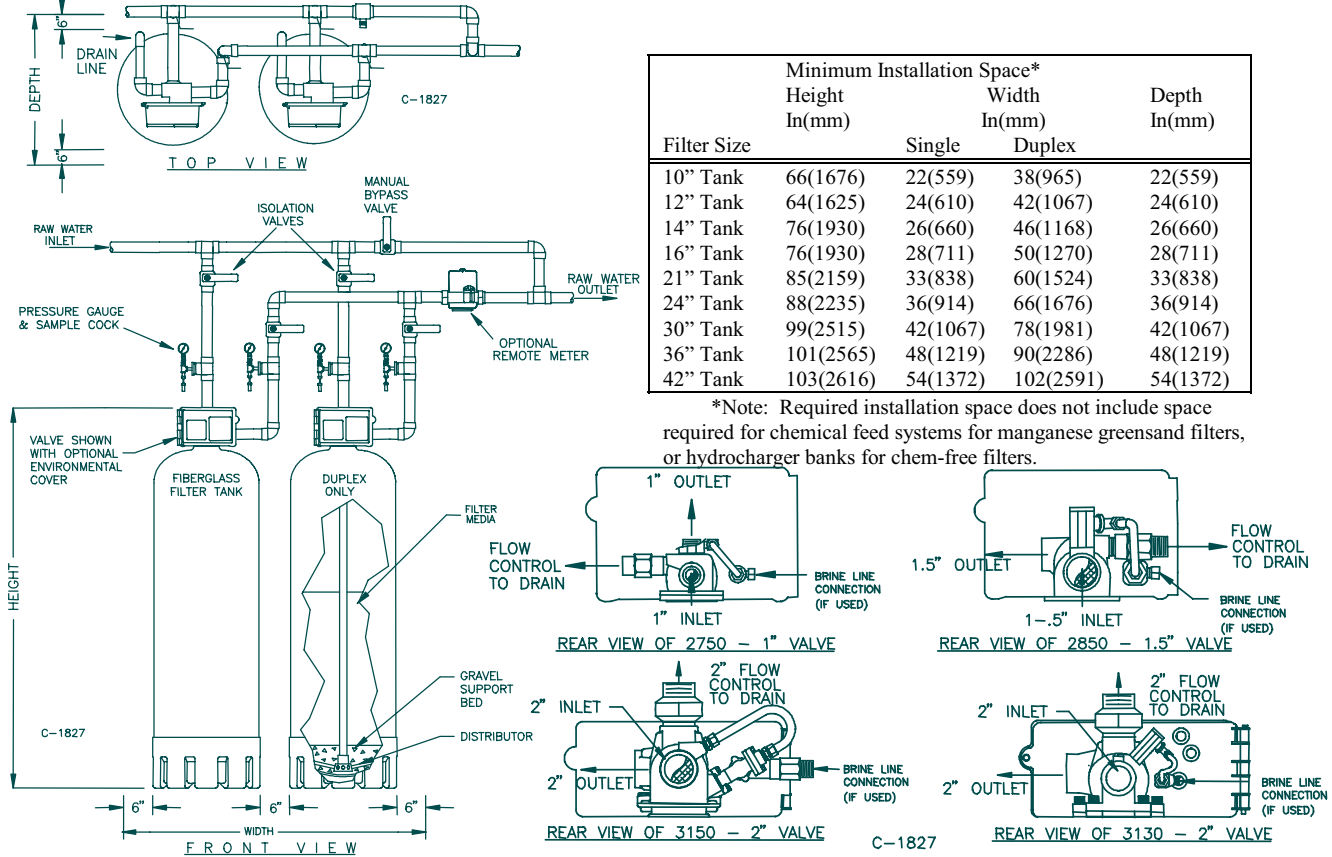
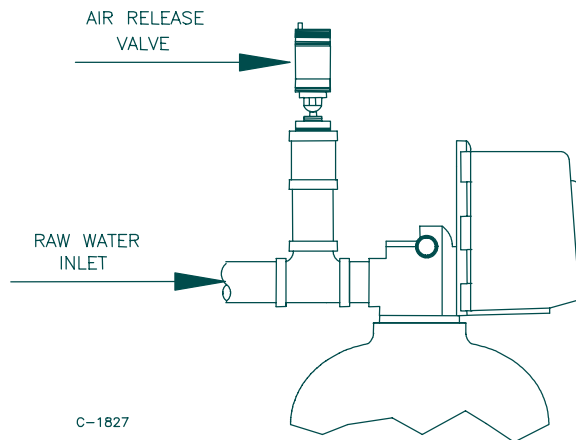

Fig. 4.1 Typical Filter Installation

- For chemical free filters, ensure that an air release is installed on the filter service inlet to release any air that may remain undissolved in the raw water. Make the riser pipe as long as possible (minimum recommended 8") to act as an air collector.



### 4.3.1 Injection Pump Installation, (Manganese Greensand Filters Only)

Position the chemical solution tank and chemical injection pump as close to the service inlet piping, and as far upstream of the filter system as possible. Locating the chemical pump as close to the chemical tank as practical, keeping the suction tubing as short as possible. Also try to keep the tubing between the chemical pump and the injection point to a minimum. Installing the chemical injection system as far upstream as possible gives the potassium permanganate a maximum amount of contact time with the water before entering the filters. It also allows the potassium permanganate to mix thoroughly in the water before entering the filter(s). The tip of the injection quill should be cut at 45°, with the angle facing away from the direction of flow, and be located in the center of the flow stream. This

- Install the injection fittings into the chemical pump head, and the inlet piping.
- Connect the tubing to the pump head. The clear, soft length of tubing is the pump feed piping, which runs down into the solution tank. Make sure that the foot valve and ceramic anchor are installed on the end of the feed tubing to ensure that the tubing remains in the bottom of the solution tank at all times. The longer piece of stiff tubing runs from the pump outlet to the injection fittings. Ensure that no kinks or foreign material are clogging either the suction or discharge tubing.
- For more details on the chemical injection pump installation, please refer to the manual accompanying the chemical injection pump.

optimises the mixing of the potassium permanganate with the influent raw water.

*Note: In applications where the water supply is cycling on and off by a pressure tank/pump system, the injection fitting must be installed BEFORE the pressure tank.*

*Note: In applications where there is a varying flowrate, an optional "paced" chemical pump with a contacting meter is recommended. The contacting meter are normally installed just before the injection point.*

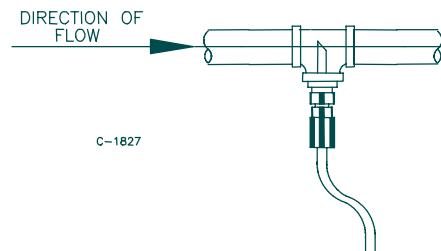

Fig. 4.3 Injection Fitting Installation

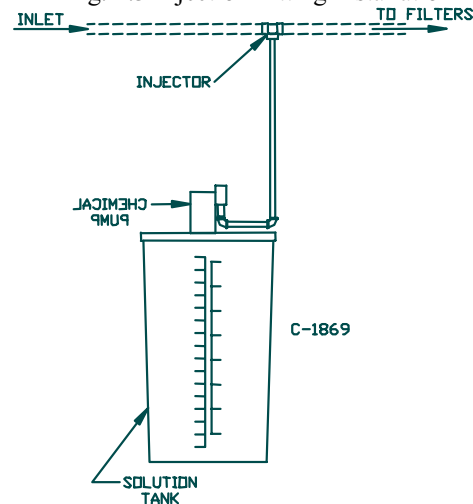

Fig. 4.4 Chemical Injection Pump Installation

### 4.3.2 Hydrocharger Installation, (Chemical Free Filters Only)

- For hydrocharger installation, it is recommended that the hydrocharger be installed as far upstream as possible, while still remaining easily accessible for adjustment and maintenance.
- The hydrocharger must be installed level and horizontal in order to maximize the air induction efficiency. Pressure gauges should be installed on the inlet and outlet of the hydrocharger bank in order to monitor the pressure drop across the bank.

*Note: The system must be designed so the hydrocharger bank draws air continuously.*

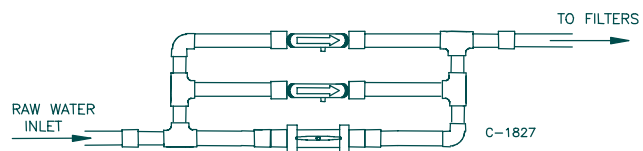

Fig. 4.5 Hydrocharger Bank Installation

### 4.3.3 Optional Treated Water Regeneration Installation

- The treated water regeneration kit allows a clean, water source to be used as the regeneration water supply which results in a more efficient regeneration.
- The treated water regeneration kit consists of two, pneumatically or hydraulically actuated diaphragm valves (per unit) installed in the piping, as shown on the drawing shown:

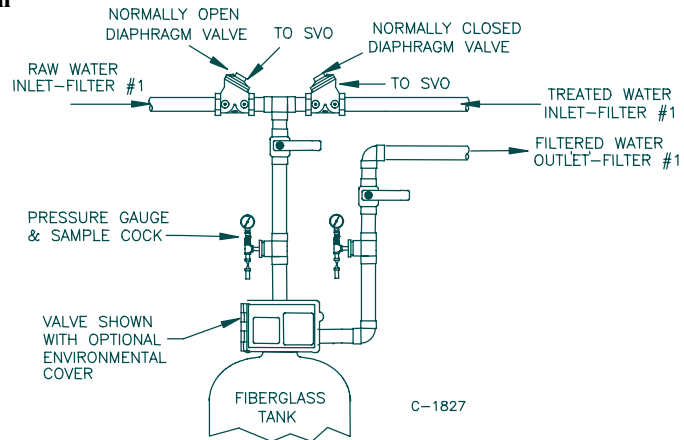

Fig. 4.6 Treated Water Regeneration Kit Typical Installation

- The two diaphragm valves are controlled by a service valve operator, or SVO. There are two different SVO's; one used for the 2750 & 2850 valves, and another used for the 3150 valve. Both are shown here.

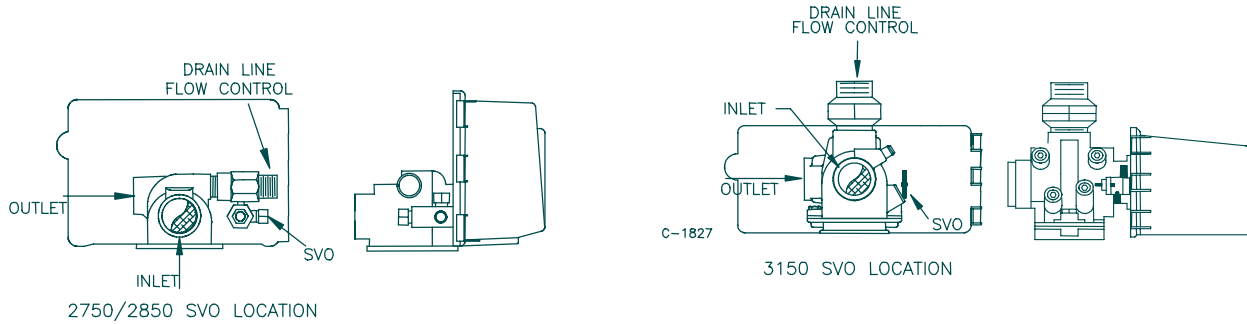

Fig. 4.7 Service Valve Operator Location (2850 & 3150 shown)

- An SVO, or service valve operator has three ports, drain, pressure, and control valve. The diaphragm below illustrates the location of each of these ports on the SVO. To ensure proper operation of the diaphragm valves, the supply pressure must be a continuous water pressure source and the pressure must be equal to the highest pressure the system will see. If this is not possible, air pressure may also be used with the air pressure set to the highest water pressure the system will see.

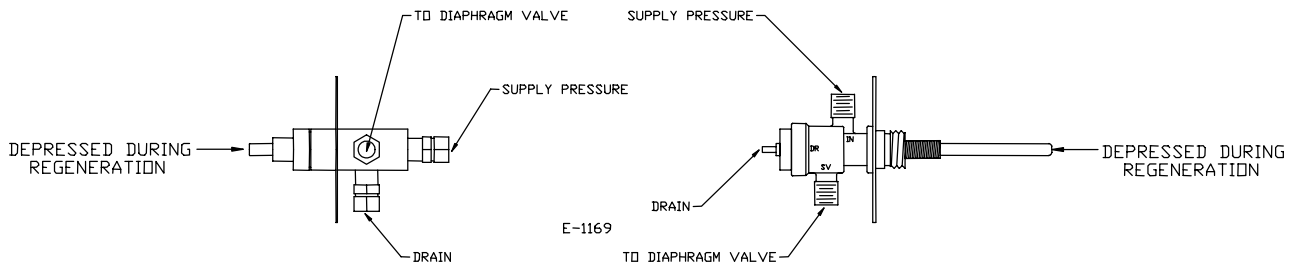

Fig. 4.8 SVO Port Identification

4.4.1 Standard and ET Controlled Units

Electrically connect each unit together with the interconnect cable supplied on the units. The lead unit is denoted by having the power cord. External wiring to be done according to federal and provincial regulations, with the power coming from a fused source.

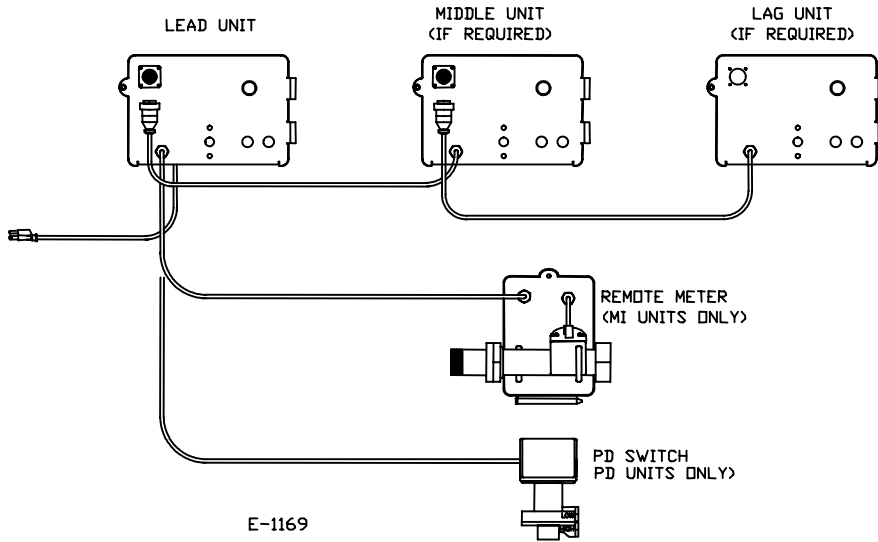

Fig. 4.9 Mechanically and ET Controlled Multiple 2750/2850 Unit Electrical Connection

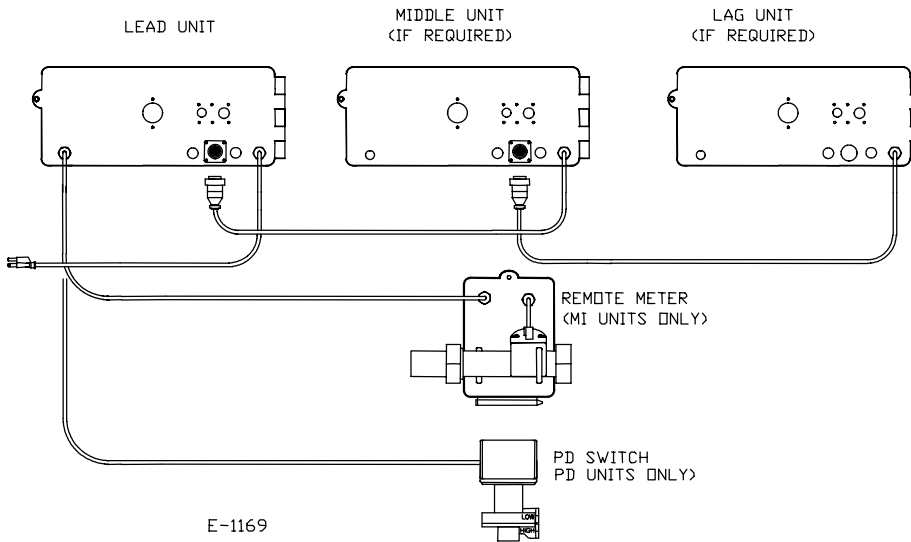

Fig. 4.10 Mechanically and ET Controlled Multiple 3150 Unit Electrical Connection

#### 4.4.2 Systemax 2000 Controlled Units

Electrically connect each unit to the Systemax Controller via the interconnect cable supplied on the control panel. All units operated by a Systemax Controller are identical, and do not require any particular order. External wiring to be done according to federal and provincial regulations, with the power coming from a fused source. Both the meter and PD switch, (if required), are electrically connected to the lead unit terminal strip.

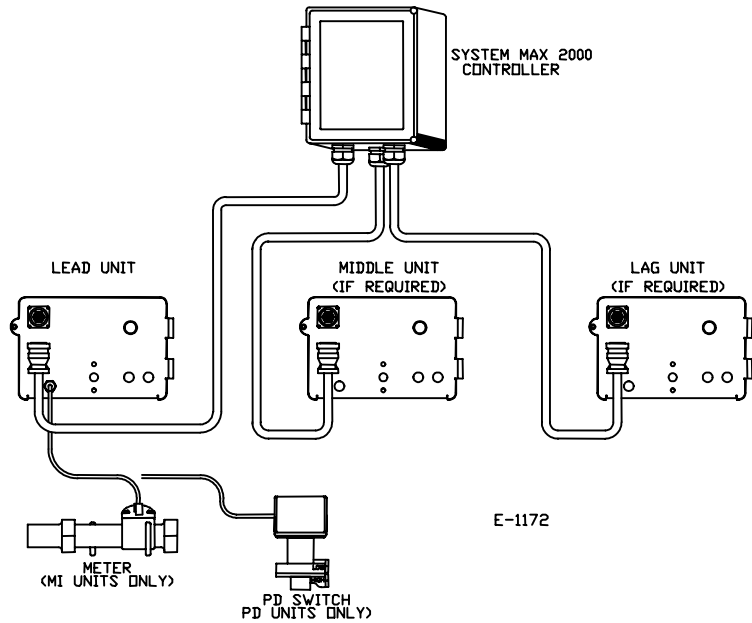

Fig. 4.11 Systemax 2000 Controlled Multiple 2750 & 2850 Unit Electrical Connections

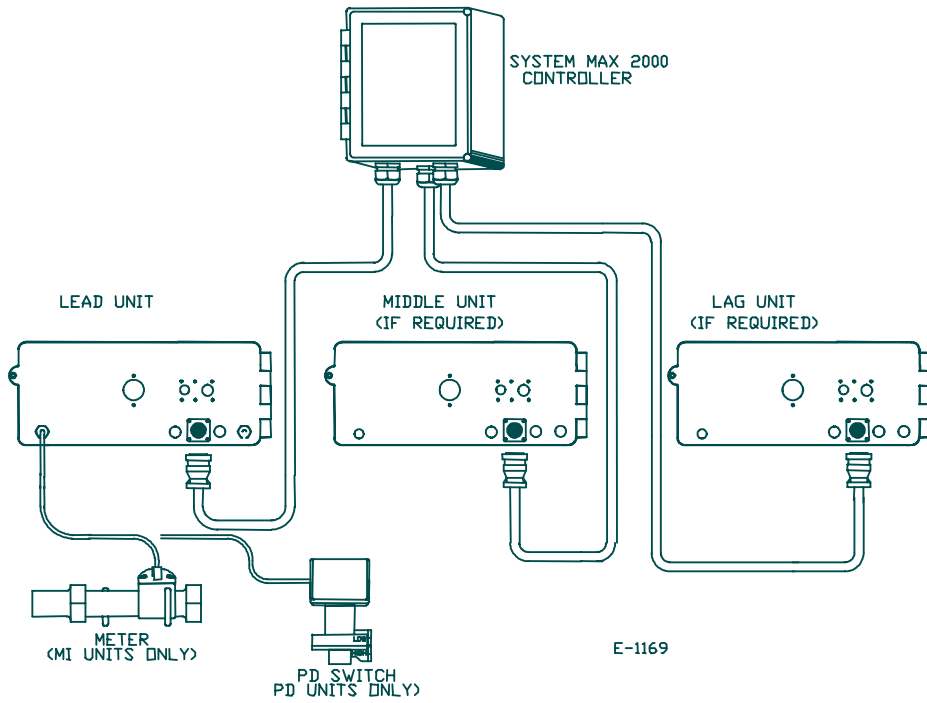

Fig. 4.12 Systemax 2000 Controlled Multiple 3150 Unit Electrical Connections

### 4.4.3 Wiring Terminations

The standard configuration of the filter valve uses a mechanical timer to control the cycle times and valves positions during operation of the filter. There are three different configurations available for the mechanical controlled valve:

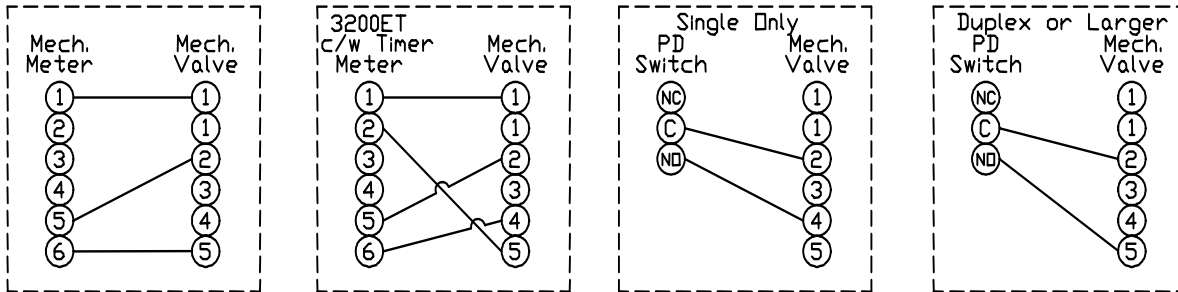

Fig. 4.13 Mechanical Control Wiring Connections

Note: U.S. companies should look at the Fleck manual for wiring diagrams

Note: For PD Switch applications, the "LOW" side of the pd switch is connected to the system service outlet, and the "HIGH" side of the pd switch is connected to the system service inlet.

There are two optional configurations for the filter valve where the mechanical timer is replaced by either a digital circuit board, called the 3200 ET digital timer/controller, or a central digital controller, called the Systemax 2000, controls either single or multiple units. Using the ET, there are two configurations available:

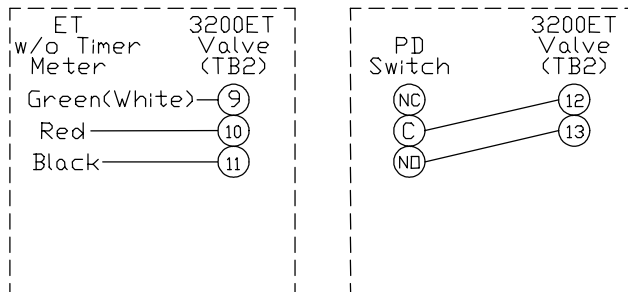

Fig. 4.14 ET Control Wiring Connections

Note: U.S. companies should look at the Fleck manual for wiring diagrams

The Systemax digital controller can operate up to three, (3), filters automatically. Wiring terminations required for the Systemax controls can be one of two ways:

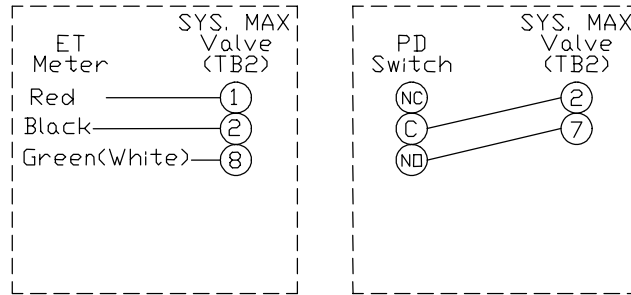
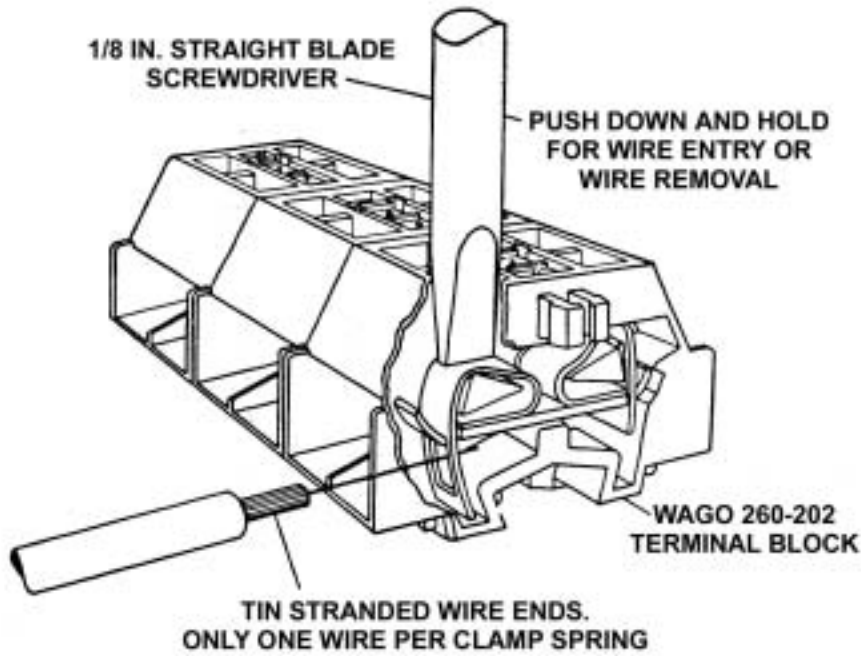

Fig. 4.15 Systemax Control Wiring Connections

Note: U.S. companies should look at the Fleck manual for wiring diagrams





## 4.4.4 Valve Wiring

### 4.4.4 Valve Wiring- Canada Only

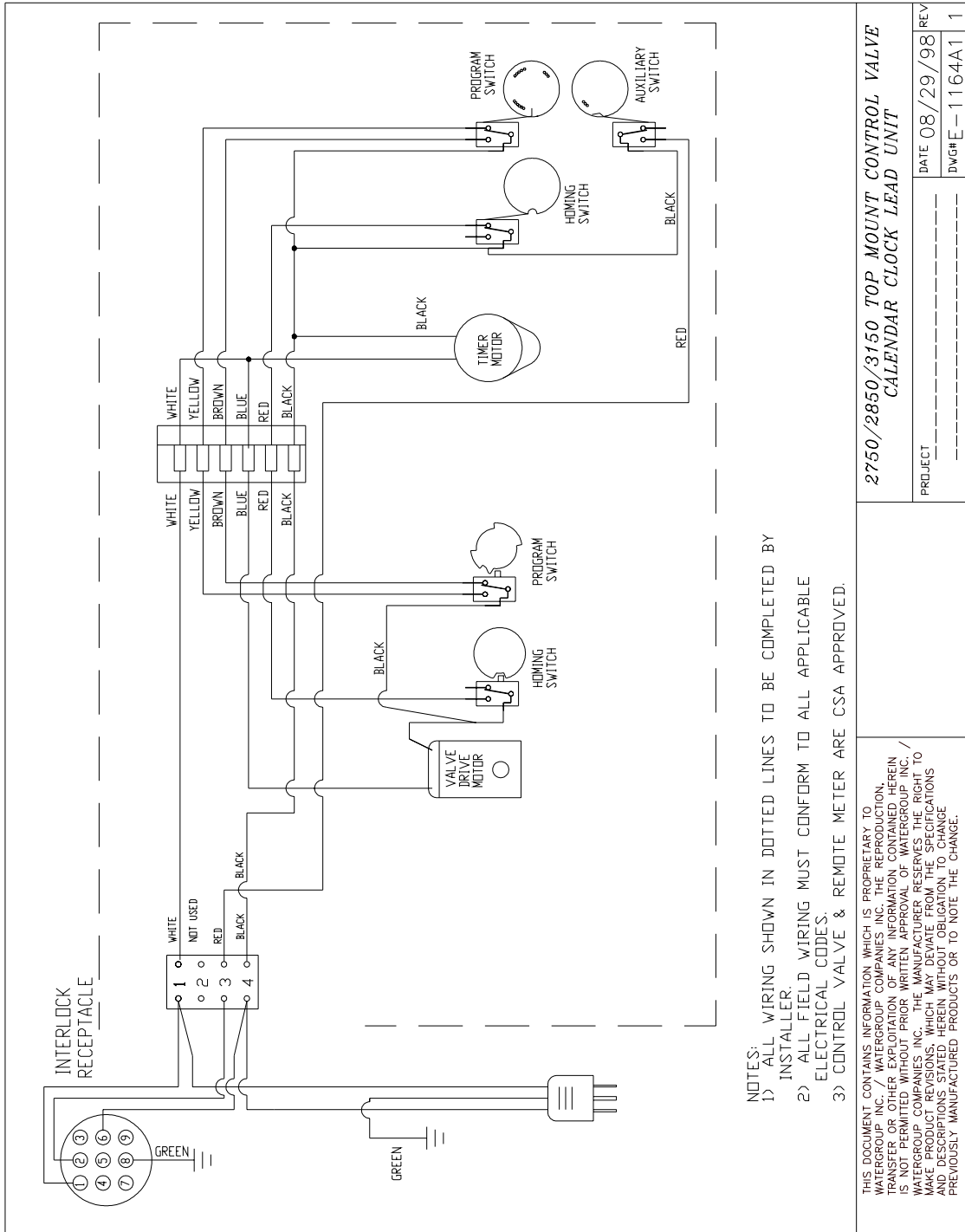

Note: U.S. companies should look at the Fleck manual for wiring diagrams

4.4.4 Valve Wiring- Canada Only

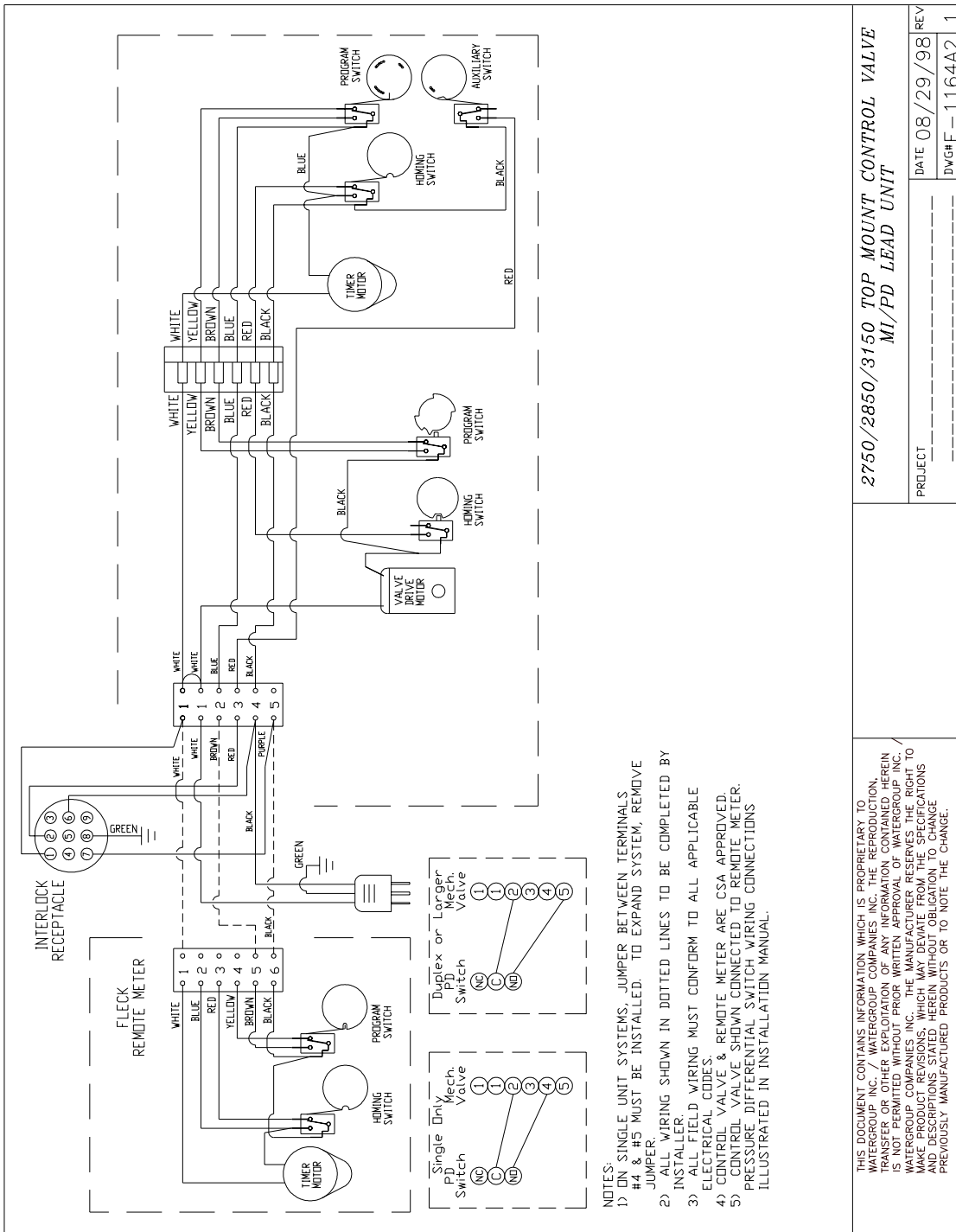

- NOTES:
- 1) ON SINGLE UNIT SYSTEMS, JUMPER BETWEEN TERMINALS #4 & #5 MUST BE INSTALLED. TO EXPAND SYSTEM, REMOVE JUMPER.
  - 2) ALL WIRING SHOWN IN DOTTED LINES TO BE COMPLETED BY INSTALLER.
  - 3) ALL FIELD WIRING MUST CONFORM TO ALL APPLICABLE ELECTRICAL CODES.
  - 4) CONTROL VALVE & REMOTE METER ARE CSA APPROVED.
  - 5) CONTROL VALVE SHOWN CONNECTED TO REMOTE METER. PRESSURE DIFFERENTIAL SWITCH WIRING CONNECTIONS ILLUSTRATED IN INSTALLATION MANUAL.

2750/2850/3150 TOP MOUNT CONTROL VALVE MI/PD LEAD UNIT	
PROJECT	DATE 08/29/98 REV
-----	-----
DWG# E-1164A2	1

THIS DOCUMENT CONTAINS INFORMATION WHICH IS PROPRIETARY TO WATERGROUP INC. / WATERGROUP COMPANIES INC. THE REPRODUCTION, TRANSFER OR OTHER EXPLOITATION OF ANY INFORMATION CONTAINED HEREIN IS NOT PERMITTED WITHOUT PRIOR WRITTEN APPROVAL OF WATERGROUP INC. / WATERGROUP COMPANIES INC. THE MANUFACTURER RESERVES THE RIGHT TO MAKE CHANGES IN DESIGN, SPECIFICATIONS, MATERIALS, DIMENSIONS AND DESCRIPTIONS STATED HEREIN WITHOUT OBLIGATION TO CHANGE PREVIOUSLY MANUFACTURED PRODUCTS OR TO NOTE THE CHANGE.

Note: U.S. companies should look at the Fleck manual for wiring diagrams

4.4.4 Valve Wiring- Canada Only

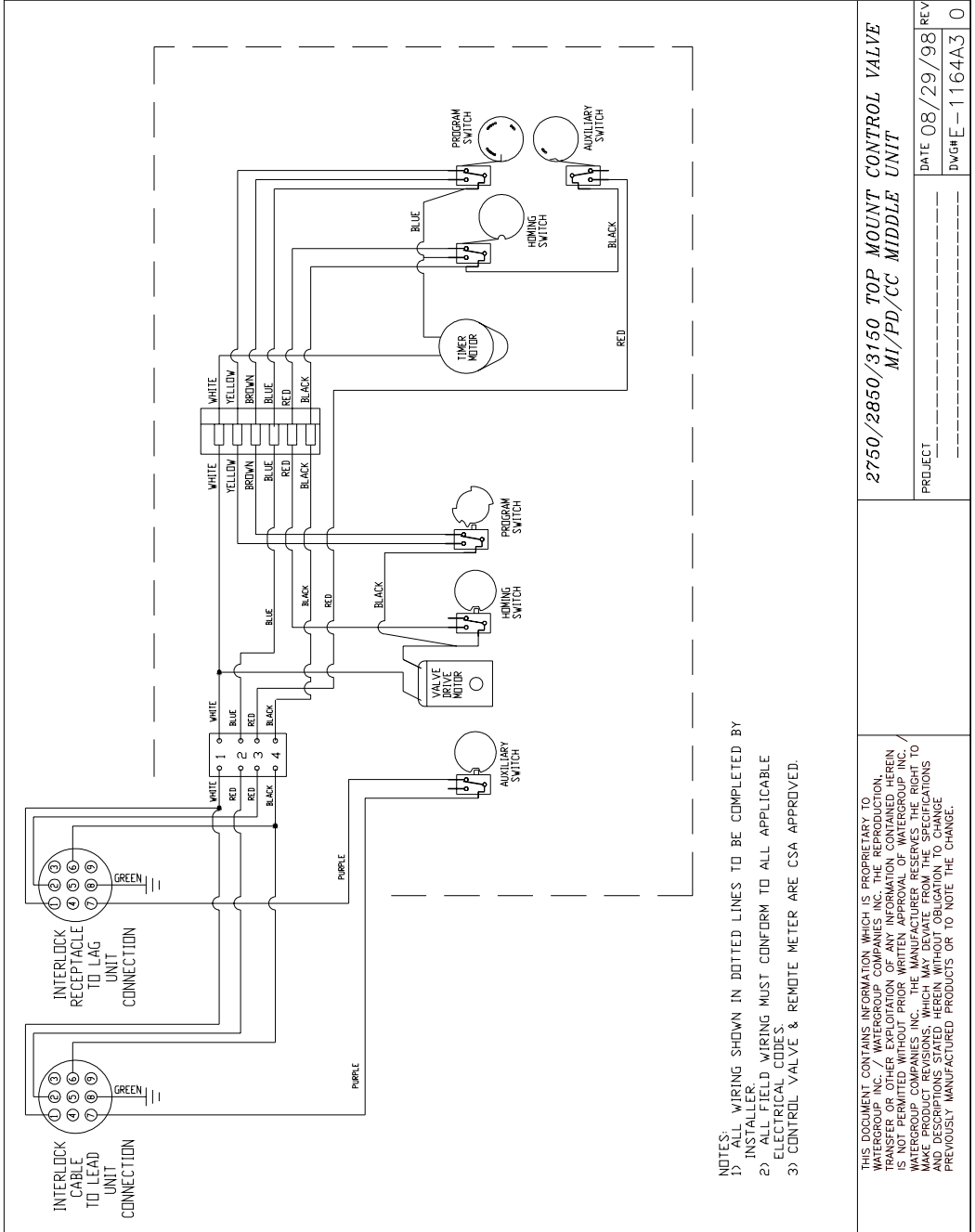

- NOTES:  
 1) ALL WIRING SHOWN IN DOTTED LINES TO BE COMPLETED BY INSTALLER.  
 2) ALL FIELD WIRING MUST CONFORM TO ALL APPLICABLE ELECTRICAL CODES.  
 3) CONTROL VALVE & REMOTE METER ARE CSA APPROVED.

2750/2850/3150 TOP MOUNT CONTROL VALVE  
 MI/PD/CC MIDDLE UNIT

THIS DOCUMENT CONTAINS INFORMATION WHICH IS PROPRIETARY TO WATERGROUP INC. / WATERGROUP COMPANIES INC. THE REPRODUCTION, TRANSFER OR OTHER EXPLOITATION OF ANY INFORMATION CONTAINED HEREIN IS STRICTLY PROHIBITED. WATERGROUP COMPANIES INC. / WATERGROUP COMPANIES INC. THE MANUFACTURER RESERVES THE RIGHT TO MAKE PRODUCT REVISIONS, WHICH MAY DEVIATE FROM THE SPECIFICATIONS AND DESCRIPTIONS STATED HEREIN WITHOUT OBLIGATION TO CHANGE PREVIOUSLY MANUFACTURED PRODUCTS OR TO NOTE THE CHANGE.

PROJECT	DATE 08/29/98	REV
	DWG# E-1164A3	0

Note: U.S. companies should look at the Fleck manual for wiring diagrams

4.4.4 Valve Wiring- Canada Only

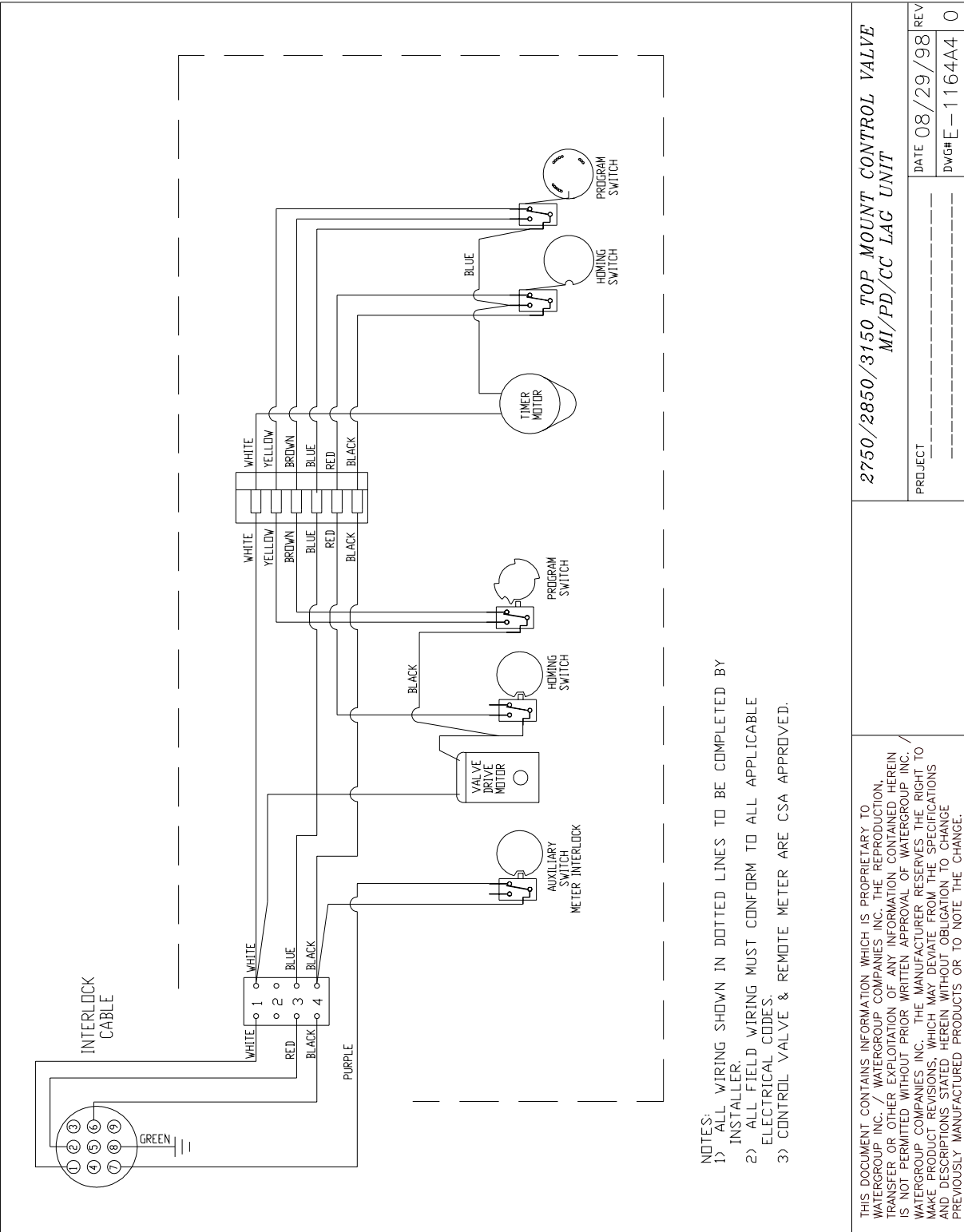

- NOTES:
- 1) ALL WIRING SHOWN IN DOTTED LINES TO BE COMPLETED BY INSTALLER.
  - 2) ALL FIELD WIRING MUST CONFORM TO ALL APPLICABLE ELECTRICAL CODES.
  - 3) CONTROL VALVE & REMOTE METER ARE CSA APPROVED.

<b>2750/2850/3150 TOP MOUNT CONTROL VALVE</b> <b>MI/PD/CC LAG UNIT</b>	
PROJECT: _____	DATE: 08/29/98
REV: _____	DWG#: E-1164A4
THIS DOCUMENT CONTAINS INFORMATION WHICH IS PROPRIETARY TO WATERGROUP INC. / WATERGROUP COMPANIES INC. THE REPRODUCTION, TRANSFER OR OTHER EXPLOITATION OF ANY INFORMATION CONTAINED HEREIN IS NOT PERMITTED WITHOUT PRIOR WRITTEN APPROVAL OF WATERGROUP INC. / WATERGROUP COMPANIES INC. THE MANUFACTURER RESERVES THE RIGHT TO MAKE PRODUCT REVISIONS, WHICH MAY DEVAUATE FROM THE SPECIFICATIONS AND DESCRIPTIONS STATED HEREIN WITHOUT OBLIGATION TO CHANGE PREVIOUSLY MANUFACTURED PRODUCTS OR TO NOTE THE CHANGE.	

Note: U.S. companies should look at the Fleck manual for wiring diagrams

## Section 5. Media Specifications

There are six different types for filters used in the removal of various components in water:

Filter Type:	Model No. Designation:
• MultiMedia	(AMM)
• Manganese Greensand	(AMG)
• Manganese Greensand Plus	(AMG)
• Activated Carbon	(AAC)
• Chemical Free	(ACF)
• Neutralizing	(AVR)
• Birm	(ABF)

These media beds are composed of different combinations of the following types of filtration media:

### 5.1 Media Description

Media	Description	Density (lb/ft <sup>3</sup> )
Anthrafilt	Graded anthracite coal aggregate. Black in color.	52
Fine Filter Sand	Finely crushed glacial deposit	100
Fine Garnet	Almandine garnet crushed to an effective size of 0.37 mm. Red/violet in color.	125
Coarse Garnet	Almandine garnet crushed to an effective size of 1.22 mm. Slightly darker than fine garnet	140
Manganese Greensand	Purplish-Black media processes from Glauconite greensand.	85
Manganese Greensand Plus	Has all the performance characteristics of Manganese Greensand plus improved resistance in high temperature, high differential pressure and low dissolved solids applications	85
Calcium Carbonate	crushed and screened white marble	90
Magnesium Oxide	processed bead-like magnesia	82
Activated Carbon	Granular activated carbon, made from bituminous coal.	23
Birm	Black in color	47
Fine Gravel	1/8" x 1/16" graded and washed quartz	100
Medium Gravel	1/4" x 1/8" graded and washed quartz	100
Coarse Gravel	1/2" x 1/4" graded and washed quartz	100

### 5.2 Media Bed Quantities

Note: All media quantities listed are in cubic feet

#### 5.2.1 Special Media Loading, (Optional)

Layer	Media	Quantity
1		
2		
3		
4		
5		
6		

**5.2.2 AMM - MultiMedia Bed:**

Filter Diameter	Anthrafilt	Fine Sand	Fine Garnet	Coarse Garnet	Fine Gravel	Medium Gravel	Coarse Gravel	Part Number	Media Shipping Weight (lbs)
21"	3.75	0.75	0.75	0.75	0.30	0.30	0.50	450021	579
24"	5.00	1.00	1.00	1.00	0.50	0.50	0.60	450024	785

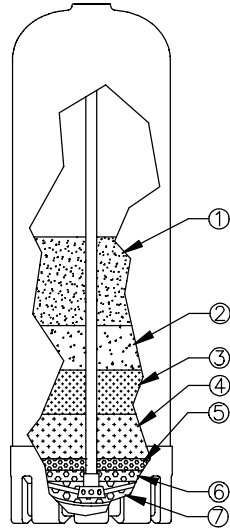

Layer:

1. Anthrafilt
2. Fine Filter Sand
3. Fine Garnet
4. Coarse Garnet
5. Fine Gravel
6. Medium Gravel
7. Coarse Gravel

**5.2.3 AMG - Manganese Greensand Bed**

Filter Diameter	Anthrafilt	Manganese Greensand	Fine Gravel	Medium Gravel	Coarse Gravel	Part Number	Media Shipping Weight (lbs)
21"	1.20	4.80	0.30	0.30	0.50	450521	581
24"	1.60	6.40	0.50	0.50	0.60	450524	788

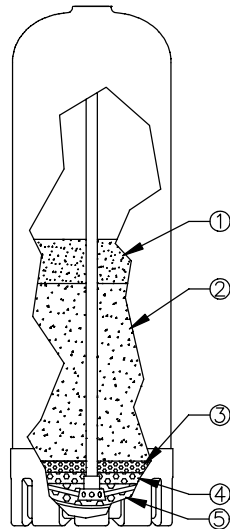

Layer:

1. Anthrafilt
2. Manganese Greensand
3. Fine Gravel
4. Medium Gravel
5. Coarse Gravel

**5.2.4 AAC - Activated Carbon Bed**

Filter Diameter	Activated Carbon	Fine Gravel	Medium Gravel	Coarse Gravel	Part Number	Media Shipping Weight (lbs)
21"	6.00	0.30	0.30	0.50	450421	248
24"	8.50	0.50	0.50	0.60	450424	356

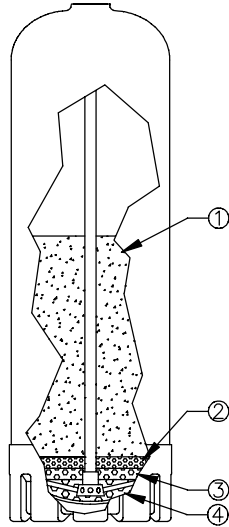

Layer:

1. Activated Carbon
2. Fine Gravel
3. Medium Gravel
4. Coarse Gravel

**5.2.5 ACF - Chemical Free Media Bed**

Filter Diameter	Magnesium Oxide	Calcium Carbonate	Fine Sand	Fine Gravel	Medium Gravel	Coarse Gravel	Part Number	Media Shipping Weight (lbs)
21"	0.36	4.20	1.44	0.30	0.30	0.50	450621	622
24"	0.50	5.60	1.9	0.50	0.50	0.60	450624	842

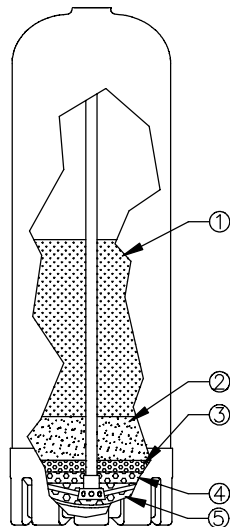

Layer:

1. Magnesium Oxide/Calcium Carbonate Mixture
2. Fine Filter Sand
3. Fine Gravel
4. Medium Gravel
5. Coarse Gravel

**5.2.6 AVR - Neutralizing Bed:**

Filter Diameter	Anthraflit	Calcium Carbonate	Fine Sand	Fine Garnet	Coarse Garnet	Fine Gravel	Medium Gravel	Coarse Gravel	Part Number	Media Shipping Weight (lbs)
21"	1.25	2.50	0.75	0.75	0.75	0.30	0.30	0.50	450321	654
24"	1.60	3.40	1.00	1.00	1.00	0.50	0.50	0.60	450324	887

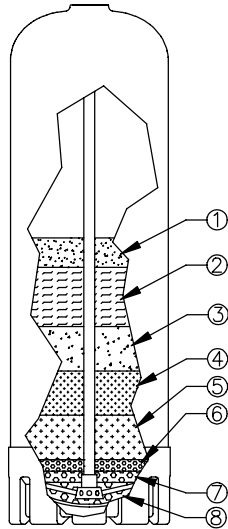

Layer:

1. Anthraflit
2. Calcium Carbonate
3. Fine Filter Sand
4. Fine Garnet
5. Coarse Garnet
6. Fine Gravel
7. Medium Gravel
8. Coarse Gravel

**5.2.7 ABF - Birm Bed**

Filter Diameter	Birm	Fine Gravel	Medium Gravel	Coarse Gravel	Part Number	Media Shipping Weight (lbs)
21"	6.00	0.30	0.30	0.50	450821	392
24"	8.00	0.50	0.50	0.60	450824	536

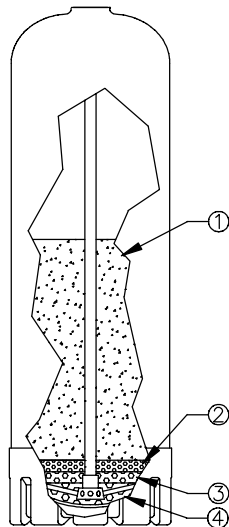

Layer:

1. Birm
2. Fine Gravel
3. Medium Gravel
4. Coarse Gravel



## Section 6. 2850 Valved Filter Parts Breakdown

Note: Unit shown with Environmental Enclosure which is standard on ET and Systemax units. Standard mechanical units equipped with standard enclosure.

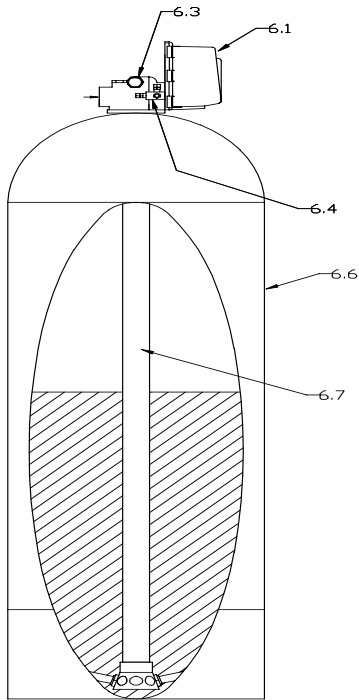

Fig. 5.1 Filter Unit

### 6.0.1 Control Valve:

Valve	Part Number
2850 CC Lead	285061
2850 PD/MI Lead	285062
2850 Middle	285064
2850 Lag	285063
2840 ET Lead	285067
2850 ET Middle	285069
2850 ET Lag	285068
2850 Systemax	285060
Side Mount Adapter	61415

### Abbreviations:

CC: Calendar Clock Initiation

MI: Meter Initiation

PD: Pressure Differential Initiation

Notes:- Lead valve in any multiple unit system is responsible for initiating the regeneration sequence.

- Lag valve in any multiple unit system must be installed at the end of a multi unit system.

- Middle valve(s) must be installed between the lead and lag valves in a multi unit system.

6.0.2 Remote Meters, (not shown, MI initiated units only). 1.5" Std meter included with standard MI 21" or 24" filter system

Meter Size	Part Number	Flow Range	Gal. Range
1.5" Std. Range	19512	1.5-75.0 USGPM	625-10,625
1.5" Ext. Range	Special	1.5-75.0 USGPM	3,125-53,125
1.5" ET w/o Timer	60614	1.5-75.0 USGPM	N/A
2" Std. Range	17527	3-150 USGPM	1,250-21,250
2" Ext. Range	Special	3-150 USGPM	6,250-106,250
2" ET w/o Timer	60616	3-150 USGPM	N/A

### 6.0.3 Backwash Flow Controls

Flowrate	Part Number	Pipe Size
25 USGPM	60710-25	1"
30 USGPM	13640	1"
40 USGPM	60711-40	2"

- BW flow control dependent upon filter model. Refer to section 2.5 for BWFC sizes and recommended drain pipe size.

6.0.4 SVO, only (Service Valve Operator):(for treated water regeneration) #13920A

6.0.5 Media Bed: See section 5.2 for part numbers

6.0.6 Tank:(White):

Diameter	Approx. Height	Part Number
21"x 69"- 4" Top Hole	69"	100419
24"x 72"- 4" Top Hole	71"	100421

6.0.7 Distribution: For 21" or 24" tanks #61001

6.0.8 Accessories (not shown)

Braukman air release #50701

Hydrocharger only (Brass) # 32381

AMG Std. Chemical Feed Pump, LC03SAVTC-1 #01886

AMG Std 45 USG Chemical Tank (natural) #410380

PD Switch, (not shown, PD initiated units only): #37704

PD Switch tubing kit #410396

Treated water regen backwash diaphragm valve kit (requires SVO) includes one N.O. & one N.C. 1.5" diaphragm valves # 19608

**Section 6.1 2850 Control Drive Assembly**

---

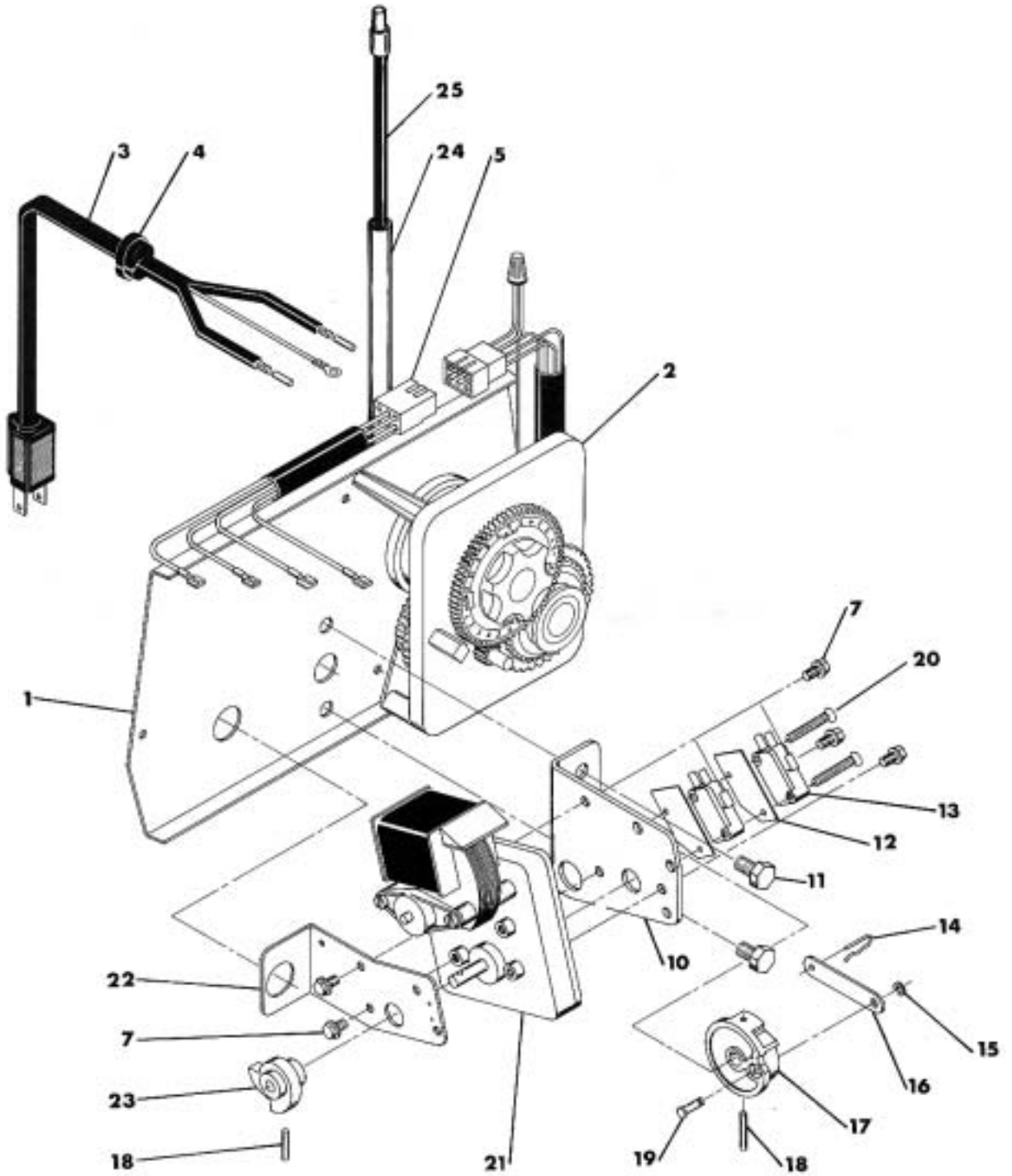

**Section 6.1 2850 Typical Control Drive Assembly**

1	1	14884	<b>Back Plate</b>
	1	11828	<b>Backplate used on all SYSTEM filters (not shown)</b>
	1	11209	<b>Back Plate-Slant Front(not shown)</b>
	1	15156	<b>Back Plate-SVO(not shown)</b>
2	1		<b>Timer-3200-7Day</b>
			<b>-3200-12 Day</b>
			<b>-3210 Meter</b>
3	1	11838	<b>Power Cord</b>
4	1	13547	<b>Strain Relief (lead valves only)</b>
	1	13547-02	<b>Strain Relief (middle &amp; lag valves only)</b>
5	1	11667	<b>Wire Harness (must specify CC lead valve)</b>
	1	16336	<b>Wire Harness (must specify pd/mi leador middle or lag valve)</b>
7	5	10872	<b>Screw-Motor Mounting</b>
8			<b>Not Assigned</b>
9			<b>Not Assigned</b>
10	1	10774	<b>Bracket-Motor Mounting</b>
11	2	10231	<b>Screw-Drive Mounting</b>
12	2	10302	<b>Insulator</b>
13	2 or 3	10218	<b>Switch (2 for lead valves 3 for all others)</b>
	2	11805	<b>Screws (not shown) (to attach 10218 to bracket 22 middle &amp; lag valves)</b>
14	1	10909	<b>Connecting Link Pin</b>
15	3	10250	<b>Retaining Ring</b>
16	1	10621	<b>Connecting Link</b>
17	1	12102	<b>Drive Cam-RR (filters white)</b>
	1	12576	<b>Drive Cam-STF (softeners black)</b>
18	2	10338	<b>Roll Pin</b>
19	1	13366	<b>Drive Bearing</b>
20	2	14923	<b>Screw-Switch Mounting</b>
21	1	10769	<b>Motor</b>
22	1	11826	<b>Bracket-Brine Valve side</b>
23	1	12777	<b>Brine Valve Cam-STF</b>
	1	10815	<b>Brine Valve Cam-RR(not shown)</b>
	1	12472	<b>Brine Valve Cam-SVO(not shown)-TRI</b>
	1	12114	<b>SVO Cam Bracket (not Shown)</b>
24	1	15441	<b>Meter Cable Guide Assembly</b>
25	1	15513	<b>Meter Cable Assembly</b>
26	2	10300	<b>Screw-Timed Mounting(not shown)</b>
27	2	15742	<b>Screw(not shown)</b>
28	2	15833	<b>Spacer,Cover(not shown)</b>
29	1	19291-020	<b>Cover,1 Piece,Black(not shown)</b>
30	2	19367	<b>Screw,Cover(not shown)</b>
	1	19010	<b>9 Pin Receptacle (Lead &amp; Middle Valves Only)</b>
	1	19009	<b>9 Pin Cable ( Middle &amp; Lag Valves Only)</b>

Section 6.2 2850 Valve Timer Assembly

---

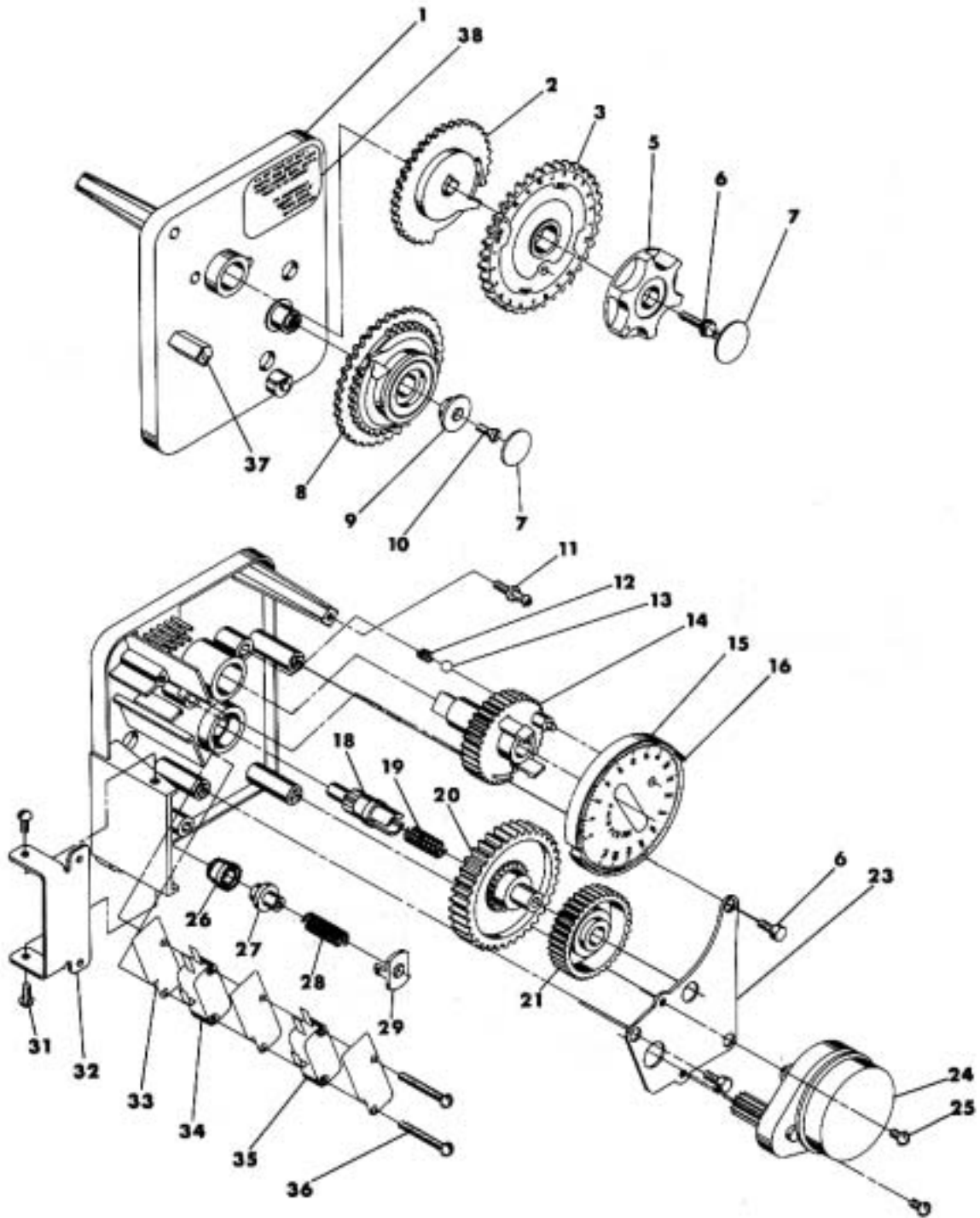

Section 6.2 2850 Valve Timer

ITEM NO.	NO.REQ'D	PART NO.	DESCRIPTION
1	1	13870-01	Timer Housing Assembly
2	1	13802	Cycle Actuator Gear (Domestic Only)
	1	13011	Cycle Actuator Gear (All Filter Systems)
3	1	19205	24 Hour Gear Assembly,Silver
		19205-01	24 Hour Gear Assembly,Tan (CC Lead Valve: Specify Regeneration Time usually 1:00 AM)
4	1	13886-01	Knob
6	4	13296	Screw-Timer Knob & Motor Plate Mtg.
7	2	11999	Button Decal
8	1	60405-30	Program Wheel Assembly
9	1	13806	Program Wheel Retainer
10	1	13748	Screw-Program Wheel Mtg.
11	1	14265	Spring Clip
12	1	15424	Spring-Detent (CC Lead Only)
13	1	15066	Ball-1/4 in. dia. (CC Lead Only)
14	1	13911	Main Drive Gear (CC Lead Only)
	1	15055	Main Drive Gear (PD/MI Lead,Middle & Lag)
15	1	19210	Program Wheel (CC Lead Only)
	1	13880-02	Program Wheel (PD/MI Lead, Middle & Lag)
16	21	15493	Roll Pin
18	1	13018	Idler Shaft
19	1	13312	Spring-Idler
20	1	13017	Idler Gear
21	1	13164	Drive Gear (Domestic Only)
	1	15275	Drive Gear (All Filter Systems)
23	1	13887	Motor Mounting Plate
24	1	13944	Motor-110V.,60Hz
		14104	Motor-24V.,60Hz.
25	3	13278	Screw-Motor Mounting & Ground Wire
26	1	13830	Drive Pinion-Program Wheel
27	1	13831	Clutch-Drive Pinion
28	1	14276	Spring
29	1	14253	Spring Retainer
30			Not Assigned
31	2	11384	Screw-Timer Hinge
32	1	13881	Hinge Bracket
33	3	14087	Insulator
34	1	10896	Switch (CC Lead Valves Only)
	1	15314	Switch (PD/MI Lead, Middle, Lag Valves)
35	1 Or 2	15320	Switch (2 On Lead and Middle on Inside Position)
36	2	11413	Screw-Switch Mounting
37	1	14007	Decal-Time of Day
38	1	14045	Decal-Instructions (CC Lead Valve Only)
	1	15313	Decal-Instructions (PD Lead, Middle & lag Valves)
	1	15465	Decal-Instructions (MI Lead Valve)
39	1	13902	Harness-Not Shown
40	2	12681	Wire Connector-Not Shown
41	1	15354-01	Ground Wire-Not Shown

	<b>1</b>	<b>14381</b>	<b>12 Day Standard CC Skipper Wheel (Not Shown)</b>
	<b>1</b>	<b>14860</b>	<b>7 Day CC Skipper Wheel (Not Shown)</b>
	<b>1</b>	<b>13864</b>	<b>Skipper Wheel Ring (Not Shown)</b>
	<b>2</b>	<b>13311</b>	<b>Skipper Wheel Spring (Not Shown)</b>
	<b>2</b>	<b>13300</b>	<b>Skipper Wheel Ball (Not Shown)</b>
	<b>1</b>	<b>14381</b>	<b>Skipper Wheel Pointer (Not Shown)</b>
	<b>1</b>	<b>13296</b>	<b>Skipper Wheel Screw (Not Shown)</b>
	<b>1</b>	<b>43061</b>	<b>Timer Assembly CC Lead Valve</b>
	<b>1</b>	<b>4306</b>	<b>Timer Assembly PD/MI Lead Valve</b>
	<b>1</b>	<b>4306</b>	<b>Timer Assembly Middle Valve</b>
	<b>1</b>	<b>43071</b>	<b>Timer Assembly Lag Valve</b>

Section 6.3.0 2850 Valve Body (Raw Water Bypass Shown)

---

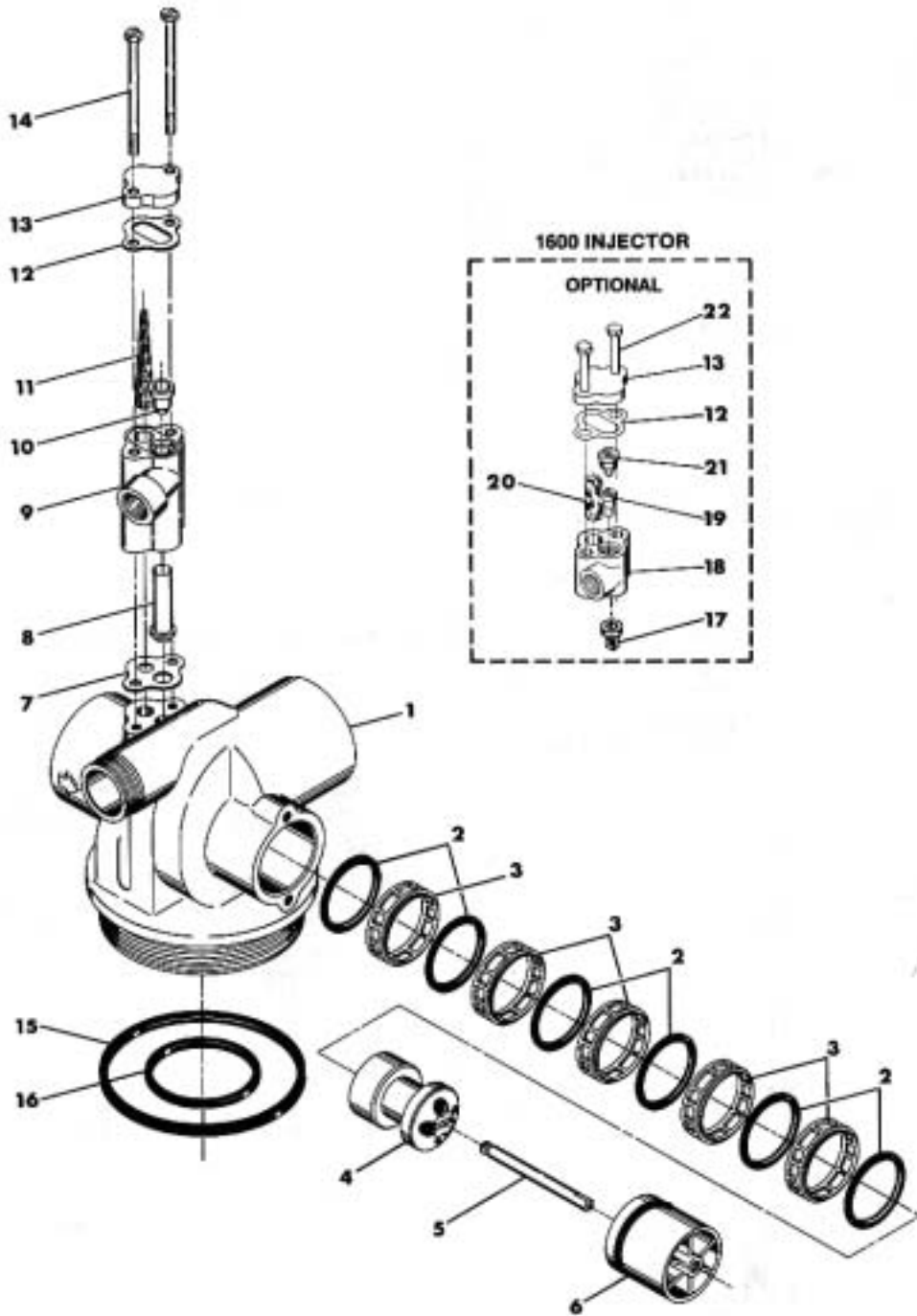

**Section 6.3.0 2850 Valve Body (Raw Water Bypass Shown)**

**CONTROL VALVE PARTS LIST**

<b>ITEM NO.</b>	<b>NO REQ'D</b>	<b>PART NO.</b>	<b>DESCRIPTION</b>
1	1	16250	Valve Body
2	6	16101	Seal - see below
3	5	16638-01	Spacer – see below
		60129	Seal & Spacer Kit (inc. #2 & #3)
	1	16638	Spacer,Hot Water
4	1	16092	Piston-Raw Water Bypass (Domestic Filters Only) See Next Page For Raw Water Bypass
5	1	16436	Piston Rod - Raw Water Bypass
6	1	16395	End Plug Assembly -Raw Water Bypass
	1	16395-01	End Plug Assembly,Hot Water -Raw WBP
7	1	14805	Injector Body Gasket (Use On Flatcap)
8	1	14802	Injector Throat
9	1	17777	Injector Body
10	1	14801	Injector Nozzle
11	1	14803	Injector Screen
12	1	10229	Injector Cover Gasket
13	1	11893	Injector Cover
14	2	14804	Screw-Injector Body
	2	15137	Screw-Flat Cap Filter
15	1	16455	“O” Ring-Top of Tank
16	1	13577	“O” Ring
17	1	16221	Air Disperser
18	1	17776	Injector Body
19	1	10914	Injector Throat
20	1	10227	Injector Screen
21	1	10913	Injector Nozzle
22	2	10692	Screw-Injector Body
23	1	60366	DLFC 1” NPT(not shown)-specify size
24	1	17996	Air Disperser,1700(not shown)
25	1	19608-15	Disperser Upper (not shown)
	1	60105	Raw Water bypass Piston Assembly
	1	60114-00	No Raw Water Bypass Piston Assembly (filter) includes everything shown on following page
	1	60114-01	No Raw Water Bypass Piston Assembly As Above less spacer & screws
	1	60114-02	No Raw Water Bypass Piston Assembly For Unit with 1600 Brine System (inc. Brine Tube)
	1	60114-03	No Raw Water Bypass Piston Assembly For Unit with 1700 Brine System (inc. Brine Tube)



Section 6.3.1 No Raw Water Bypass Piston Assembly

---

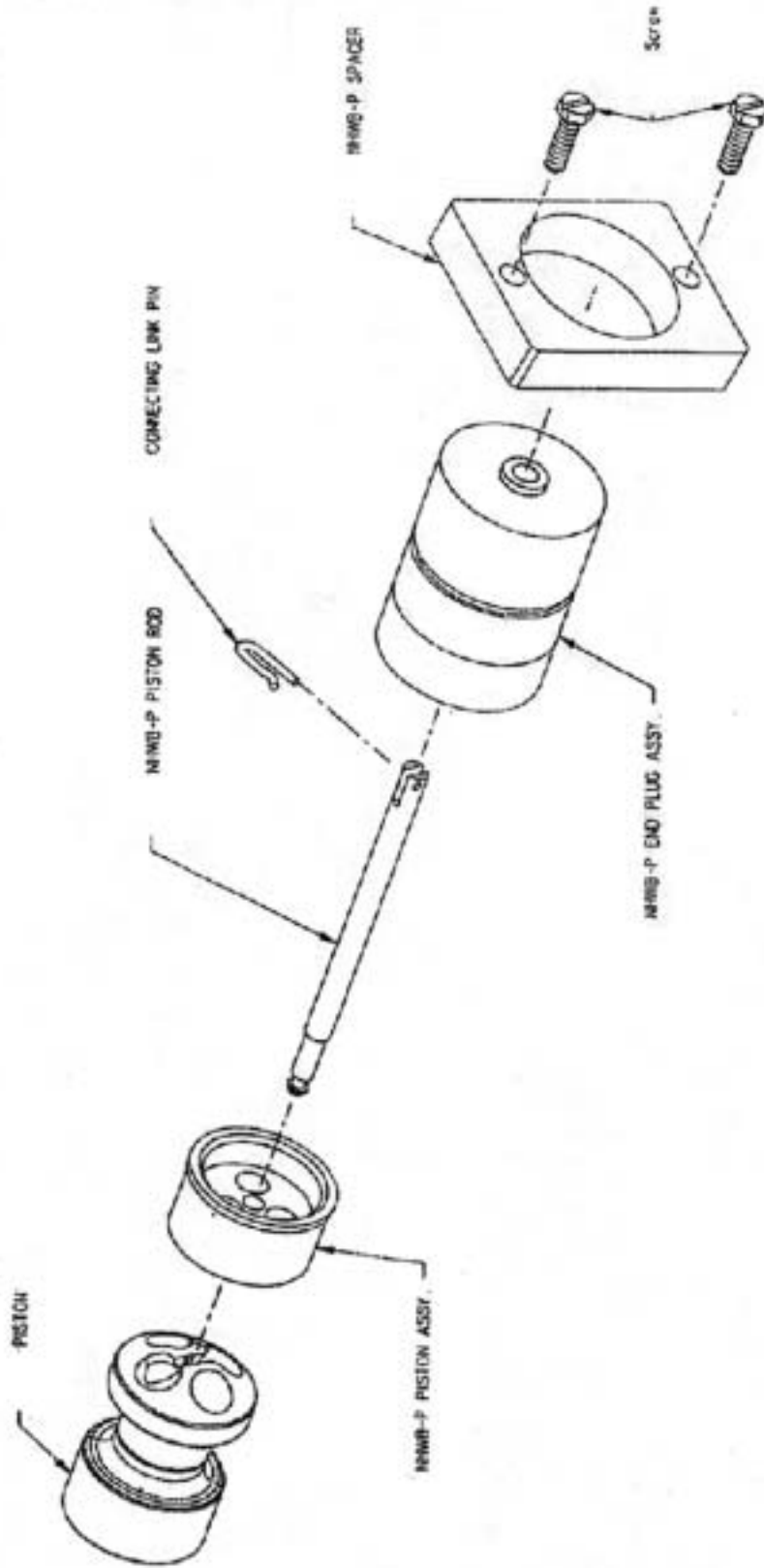

Section 6.5 2850 Valve Service Valve Operator (SVO)

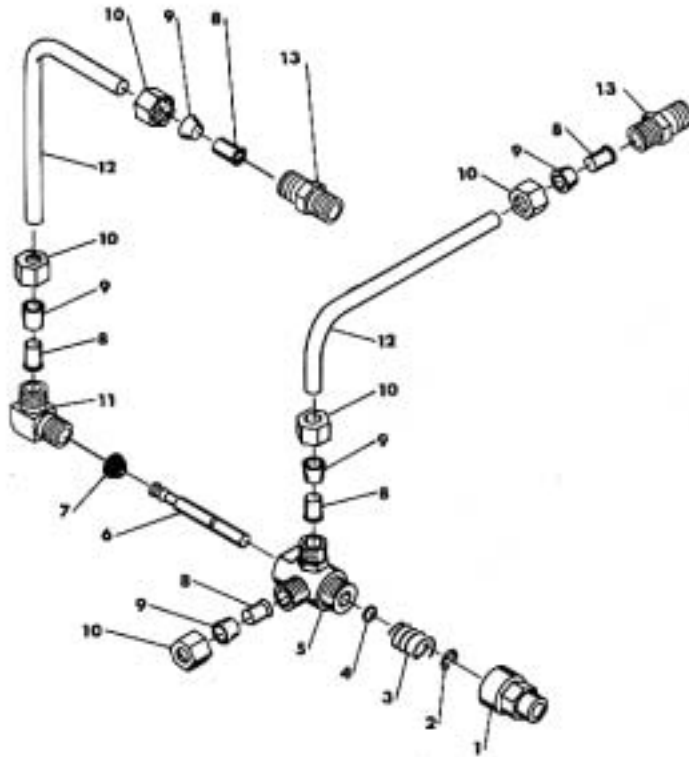

SERVICE VALVE OPERATOR PARTS LIST

<u>ITEM NO.</u>	<u>NO.REQ'D</u>	<u>PART NO.</u>	<u>DESCRIPTION</u>
1	1	11749	Guide,Brine Valve Stem
2	1	10250	Retaining Ring
3	1	10249	Spring,Brine Valve
4	1	12550	Quad Ring
5	1	10785	Service Actuator Assembly-.25gpm
6	1	12552	Brine Valve Stem,1600
7	1	12626	Seat,Brine Valve
8	5	10332	Insert,3/8"
9	5	10330	Sleeve,3/8 Delrin
10	5	10329	Nut,3/8" Brass
11	1	10328	Elbow,90 1/4"NPTx3/8"T
12	2	12897	Tube
13	2	16730	connector,Male1/8"NPT to 3/8"T

Section 6.6 1.5" Meter Assembly

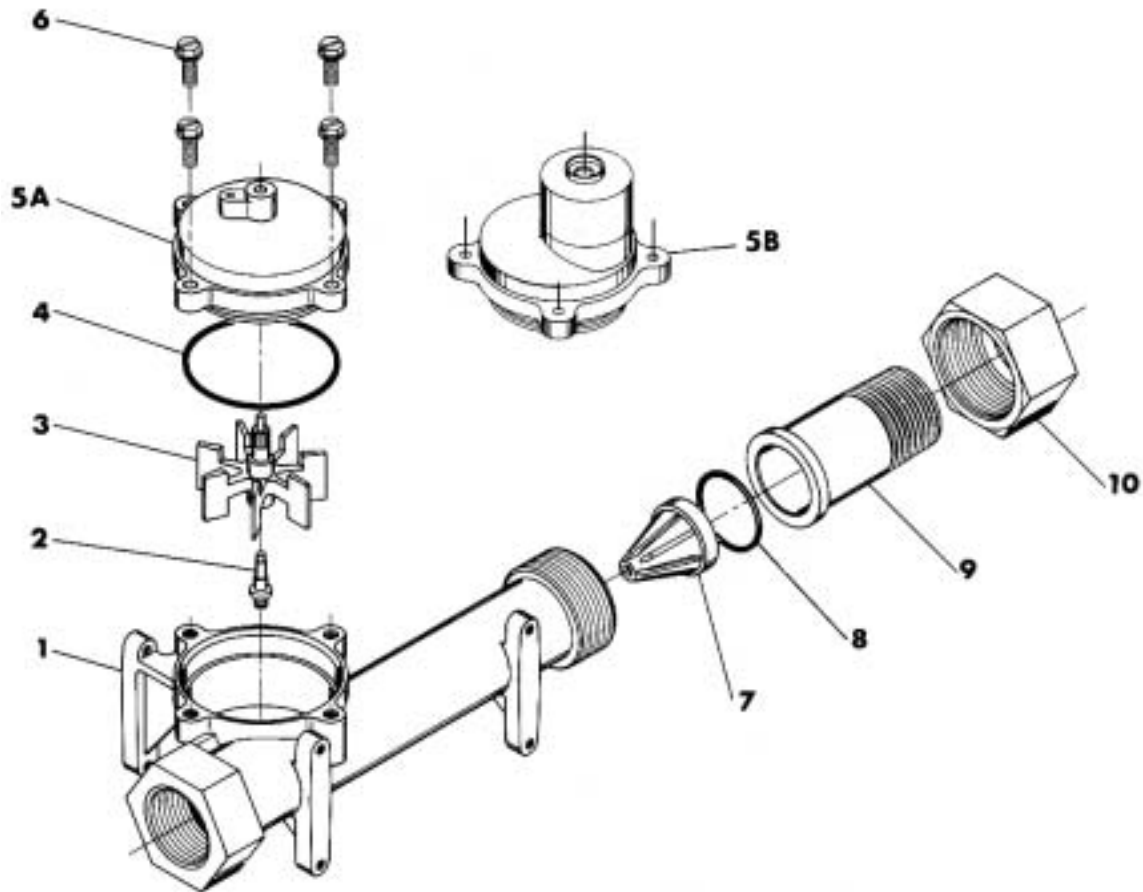

1-1/2" METER ASSEMBLY PARTS LIST

ITEM NO.	NO.REQ'D	PART NO.	DESCRIPTION
1	1	17569	Meter Body
2	1	13882	Post, Impeller
3	1	13509	Impeller
4	1	13847	"O" Ring-Meter Cover
5A	1	15218	Meter Cover Assembly (Std.)
5B	1	15237	Meter Cover Assembly (Extended Range)
6	4	12112	Screw-Meter Cover
7	1	17542	Flow Straightener
8	1	12733	"O" Ring-Quick Connect
9	1	17544	Nipple-Quick Connect
10	1	17543	Nut-Quick Connect

**Section 6.7 Remote Meter Immediate Regeneration Mechanical Timer Assembly (Standard)**

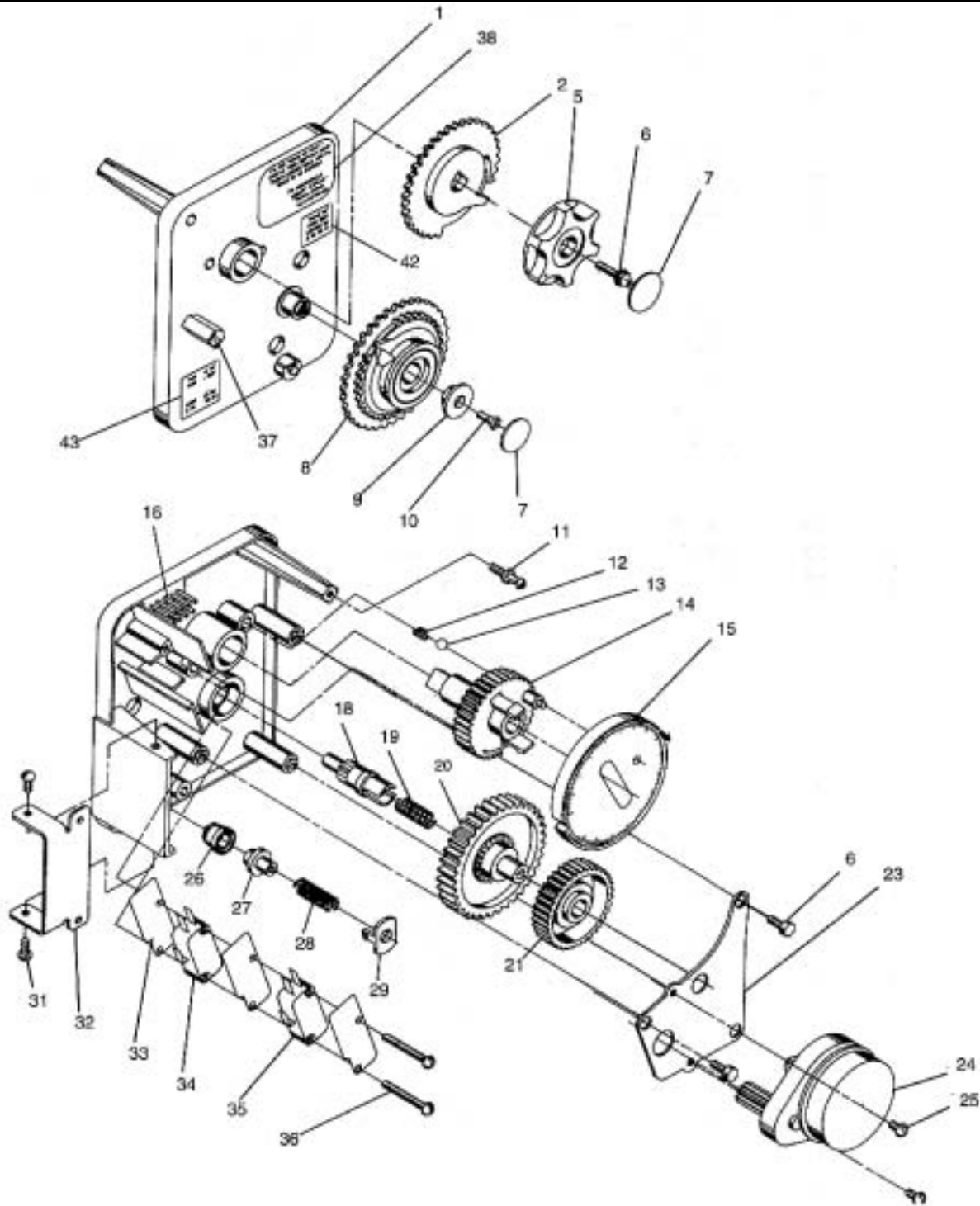

**Section 6.7 Remote Meter Immediate Regeneration Mechanical Timer Assembly**

**IMMEDIATE REGENERATION TIMER ASSEMBLY**

<b>ITEM NO.</b>	<b>PART NO.</b>	<b>QUANTITY</b>	<b>DESCRIPTION</b>
1	13870-01	1	Timer Housing Assembly
2	15431	1	Cycle Actuator Gear
5	13886-01	1	Knob
6	13296	4	Screw-Timer Knob & Motor Plate Mtg.
7	11999	2	Button Decal
8	60405	1	Program Wheel Assembly,Specify Gallons
9	13806	1	Program Wheel Retainer
10	13748	1	Screw-Program Wheel Mtg.
11	14265	1	Spring Clip
12	15424	1	Spring Detent
13	15066	1	Ball-1/4in. dia.
14	15055	1	Main Drive Gear
15	13880-04	1	Program Wheel 1RPM
16	15493	10	Roll Pin
17			Not Assigned
18	13018	1	Idler Shaft
19	13312	1	Spring Idler
20	13017	1	Idler Gear
21	13164	1	Drive e Gear
23	13887	1	Motor Mounting Plate
24	14974	1	Motor-110V.,60Hz.,1RPM
25	13278	2	Screw-Motor Mounting
26	14502	1	Drive Pinion-Program Wheel
27	14501	1	Clutch-Drive Pinion
28	14276	1	Spring
29	14253	1	Spring Retainer
30			Not Assigned
31	11384	3	Screw-Timer Hinge & Ground Wire
32	13881	1	Hinge Bracket
33	14087	3	Insulator
34	15314	1	Switch
35	10896	1	Switch,1RPM
36	11413	2	Screw-Switch Mounting
37	14007	1	Decal-Time of Day
39	13902	1	Harness-Not Shown
40	12681	2	Wire Connector-Not Shown
41	15354-01	1	Ground Wire-Not Shown
42	17870	1	Label,Indicator
43	15465	1	Label,Caution

**Section 6.7.1 Remote Meter Delayed Regeneration Mechanical Timer Assembly**

---

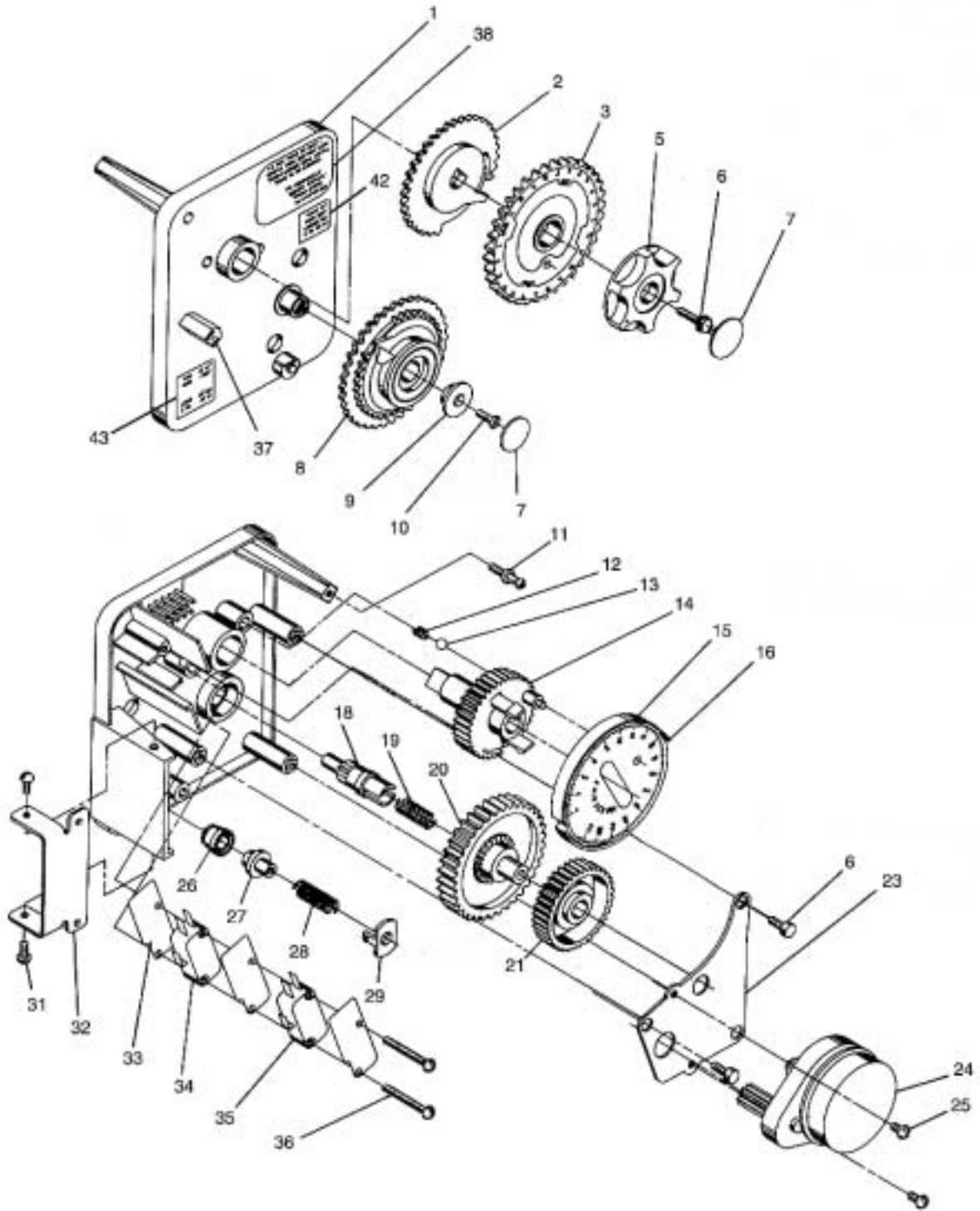

**Section 6.7.1 Remote Meter Delayed Regeneration Mechanical Timer Assembly**

**DELAYED REGENERATION TIMER ASSEMBLY**

<b>ITEM NO.</b>	<b>PART NO.</b>	<b>QUANTITY</b>	<b>DESCRIPTION</b>
1	13870-01	1	Timer Housing Assembly
2	13802	1	Cycle Actuator Gear
3	19205	1	24 Hour Gear Assembly
5	13886-01	1	Knob
6	13296	4	Screw-Timer Knob & Motor Plate Mtg.
7	11999	2	Button Decal
8	60405	1	Program Wheel Assembly,Specify Gallons
9	13806	1	Program Wheel Retainer
10	13748	1	Screw-Program Wheel Mtg.
11	14265	1	Spring Cup
12	15424	1	Spring-Detent
13	15066	1	Ball-1/4in. dia.
14	13911	1	Main Drive Gear
15	19210	1	Program Wheel Assembly
16	15493	21	Roll Pin
17			Not Assigned
18	13018	1	Idler Shaft
19	13312	1	Spring-Idler
20	13017	1	Idler Gear
21	13164	1	Drive Gear
23	13887	1	Motor Mounting Plate
24	13944	1	Motor-110V.,60Hz
	14104		Motor-24V.,60Hz
25	13278	2	Screw-Motor Mounting
26	13830	1	Drive Pinion-Program Wheel
27	13831	1	Clutch-Drive Pinion
28	14276	1	Spring
29	14253	1	Spring Retainer
30			Not Assigned
31	11384	3	Screw-timer Hinge & Ground Wire
32	13881	1	Hinge Bracket
33	14087	3	Insulator
34	10896	1	Switch
35	15320	1	Switch
36	11413	2	Screw-Switch Mounting
37	14007	1	Decal-Time of Day
38	16118	1	Decal-Instructions
39	13902	1	Harness-Not Shown
40	12681	2	Wire Connector-Not Shown
41	15354-01	1	Ground Wire-Not Shown
42	17870	1	Label,Indicator
43	15465	1	Label Caution

## Section 7. Recommended Start Up Procedure

---

### 7.1 Filter Start-Up

---

**NOTE:** *It is important to follow the startup instructions as improper start up may result in unsatisfactory filter operation or possibly damage the filter. Also on Systemax & ET units, confirm programming is as required. The programming when the unit left the factory is shown on the programming sheets in the ET or Systemax manual.*

1. Check all system piping ensuring that it is correct and all connections are complete, (see installation drawing). Ensure that all of the manual isolation and by-pass valves are closed prior to start up. Check all electrical connections and ensure that they are correct and complete.
2. Plug in the control valve, and manually advance the valve into backwash position. On a mechanical unit, this is done by removing the dust cover, and swinging the cycle timer open, in order to expose the program wheel located inside. Turn the program wheel out of the home position, until the top switch rides up onto the first set of pins. Once the valve is in this position, and the drive motor has stopped the control valve in its first position, unplug the control valve. This allows the filter to stay in this position indefinitely. To do this on the ET and Systemax units, please refer to their service manuals. For confirmation of the valve position, look at the position of the cycle cam, as shown in section 8, Filter Operation.
3. **Slowly** partially open the inlet isolation valve, and allow the filter to **slowly** fill with water. When the filter is full, water will begin to run out through the drain. ***If the unit is filled too quickly, the media could be blown out, as well as possible damage the filter.*** When full, close the inlet valve.
4. Allow the filter to stand for 1-2 hours once the tank is full to saturate the media bed (if this has not already been done during the media loading - see section 4.2)
5. Slowly open the inlet isolation valve all of the way, in order to fully backwash the media bed. This backwash should be held until all fines and particles are removed from the media bed, and the effluent water is running clear. This is especially important on the AMG (greensand) filter. This can take up to half an hour for many applications.

*Note: The backwash flow rate is automatically controlled by a flow control that has been factory set, and does not require adjustment on site. This flow rate can be checked by timing the flow during backwash running to the drain.*

6. Plug the control valve back in, and allow the filter to automatically complete its regeneration cycle.  
*Note: Once the regeneration cycle is complete, the filter is automatically placed into the service position. The filter will begin running water out to service the timer assembly return to it's home position.*
7. Once the start-up is complete, the valve control system must be configured. To configure a calendar clock, meter, or pressure differential initiated filters, please refer to sections 2.6 & 9. To configure either the ET Digital Timer, or the Systemax 2000 Controller, please refer to their service manuals and programming sheets. For manganese greensand and chemical free filters, refer to the following sections for additional start-up information.
8. Upon completion of the steps above, the filter outlet isolation valves are **slowly** opened, and the bypass valve can then be closed. The filter is now ready for normal service operation.

### 7.2 Chemical Injection Pump Start-Up, (Manganese Greensand Filters only)

---

1. Check the chemical pump system and ensure it has been correctly installed as outlined in the chemical pump manual.

**Note:** The chemical pump must be set up in a manner that it only operates when the system is in operation. On many systems, the standard chemical pump is wired in with the well pump so that it only runs when the well pump runs. On systems that the service flowrate varies, typically a contacting meter (optional) and a contacting type chemical pump (optional) is used to vary the amount of chemical (KMnO<sub>4</sub>) injected for the different flowrates. It is very important not to overfeed or underfeed the chemical as both conditions result in unsatisfactory operation. Overfeed can lead to "pink" service water, and underfeed can lead to damaging the media bed.



2. Mix up a small amount (2 gallons) of potassium permanganate (KMnO<sub>4</sub>) solution for the chemical feed system. To estimate the potassium permanganate solution strength, a few calculations must be done.
- **STEP 1**-Estimate required dosage; calculated by using the raw water analysis and multiplying the level of iron by 0.7 and the level of manganese by 1. Example: 2 ppm of iron and 0.5 ppm of manganese has a required dosage of  $(2 \times 0.7) + (0.5 \times 1) = 1.9$  ppm required dosage
  - **STEP 2**-Calculate the “Effective Rated Pump Capacity. It is desirable to run the chemical pump stroke at approximately 75% of full stroke. By doing this, it allows for some adjustment for slight changes in chemical demand and also helps reduce pump maintenance by keeping the check valves cleaner. Example: The standard chemical pump commonly used is the 12 GPD (gallon per day) pump so the rating you would use is  $0.75 \times 12 = 9$  GPD which we call “effective rated pump capacity”.
  - **NOTE:** If the chemical feed system is using a contacting meter to pace the chemical pump, an additional calculation must be done as a contact meter can further reduce the “effective rated pump capacity”.
    - The contacting meter size determines the number of contacts per gallon (GPC)(see chart below)

<u>Contacting Meter Size</u>	<u>Flow Range (usgpm)</u>	<u>Gallons Per Contact (GPC)</u>
¾”	1-20	0.25
1.0”	2-50	0.4
1.5”	4-100	1.0
2.0”	6-130	2.0

- Using the maximum flowrate, determine the number of contacts per minute. To do this, divide the Flowrate (usgpm) / Gallons Per Contact (GPC). For example, if your service flow is 90 gpm and you have a 1.5” contacting meter at 1.0 gallons per contact, then your pump will see  $90 \text{ USGPM} / 1 \text{ G/C} = 90$  contacts per minute (CPM).
- For the maximum output for a chemical pump, it must pulse at 125 pulses (contacts) per minute. You can now determine the % of capacity that your pump will be running at due to the contacting meter by taking the contacts per minute (CPM) / 125 = % capacity (due to contacting meter) : ie:  $90 \text{ contacts per minute} / 125 \text{ contacts per minute at } 100\% = 72\%$ . The pump will be running at approximately 72% capacity DUE TO THE CONTACTING METER ONLY. This is in ADDITION to the reduction of capacity due to the stroke. The total “effective rated pump capacity” when using a contacting meter is equal to  
 $\% \text{ Capacity (due to contacting meter)} \times \% \text{ Capacity (due to the stroke length)} \times \text{pump GPD}$   
 For example above  
 $0.72 \text{ (contacting meter)} \times 0.75 \text{ (stroke length)} \times 12 \text{ GPD} = 6.48$  “effective rated pump capacity”
- **STEP 3**-The estimated solution strength is now calculated by the following formula:

$$\frac{\text{SERVICE FLOWRATE (USGPM)} \times \text{REQUIRED DOSAGE (PPM)} \times 1440}{\text{EFFECTIVE RATED PUMP CAPACITY}} = \text{SOLUTION STRENGTH (PPM)}$$

Example: for system running at 90 USGPM, 2 ppm of iron and 0.5 ppm of manganese and a chemical pump rated at 12 USGPD (*No contacting meter*)

$$\frac{90 \text{ (USGPM)} \times 1.9 \text{ (PPM)} \times 1440}{8.6 \text{ (USGPD)}} = 28,630 \text{ SOLUTION STRENGTH (PPM)}$$

For the system without a contacting meter, the stock solution should be mixed up to 29,000 ppm

If the above system had a 1 ½” contacting meter, the solution strength would be

$$\frac{90 \text{ (USGPM)} \times 1.9 \text{ (PPM)} \times 1440}{6.48 \text{ (USGPD)}} = 38,000 \text{ SOLUTION STRENGTH (PPM)}$$

For the system *with a contacting meter*, the stock solution should be mixed up to 38,000 ppm

Solution Strength chart:

oz of KMnO4 in 1 USGallon of water	Solution Strength (PPM)
1	7,500
2	15,000
3	22,500
4	30,000
5	37,500
6	45,000

Make sure your mix water does not contain any iron or manganese as it will precipitate out as a sludge and can plug up the chemical feeder. The reason for initially mixing up a small amount is that depending upon the water conditions, flowrates, and actual chemical demand, the solution strength will vary. This only gives you a typical starting point and the final solution strength that works for your application may be quite different.

Temperature °F	Solubility in distilled water wt oz/US gallon
32	3.7
68	8.6
104	16.7
140	30.7

3. To start up and prime the pump, plug the chemical pump into a power source.  
*Note: DO NOT adjust the stroke length while the pump is turned off, or not operating. Doing so will damage the internal pump mechanism. Adjustment of the stroke length must only be done while the pump is in operation.*
4. To prime the pump, turn the bleed valve assembly counter clockwise to bypass the pump discharge from the pressurised destination to the recirculation tubing running back into the tank. Allow the pump to run in this position until the injection fluid is visible running back into the tank. Once this occurs return the bleed valve into the normal position, allowing the injection chemical to flow towards the pressurised destination. All air must be purged from the pump head before the pump will pump against a pressurised flow stream. Once the pump has been primed, reconnect the chemical pump into the system's control circuit.
5. Once in operation, the injection rate is varied by adjusting the stroke length of the injection pump until the desired dosage rate is achieved. On the pump the length of the displaced stroke during the movement of the pump diaphragm can be adjusted between 0% and 100%. For efficient and reliable operation of the pump, it is recommended that the stroke length be between 60% to 80%. Shorter strokes than this may not keep the injection fittings clean, and result in plugging the injection system, preventing further injection. Shorter, more rapid strokes will also wear out the internal drive mechanism faster than if longer, slower strokes are used.
6. With the filter in service, adjust the chemical dosage rate and the chemical solution strength until the factors below are satisfied:
  - Influent water has a slight pink colour to it immediately before the filter.
  - Filtered effluent water is clear, with no remaining pink colour to it.
  - Filtered effluent water has acceptable levels of iron and manganese present.
  - Chemical demand of the water has been met.

To ensure the chemical demand is being met, it is recommended that the system to be slightly overfed until pink is coming through on the effluent, and then gradually cut back on the chemical feed until the effluent become clear. ***Once your chemical strength has been determined, be sure to record it so future batches will be the same strength.***

### 7.3 Hydro-Charger Set-Up, (Chemical Free Filters only)

NOTE: The standard brass hydrochargers will only draw air if the water pressure is 50 Psi or less. If your operating pressure is higher, please contact your USF representative.

1. Upon completing the filter start-up detailed previously, the hydrocharger must be configured in order to draw in enough air in order to oxidize the iron in the water supply. Initially, ensure that the throttling screw located on the side of the hydrocharger (air injector) is turned out fully, allowing for unrestricted flow through the internal venturi bypass.
2. Open the bypass ball valve on the hydrocharger assembly.

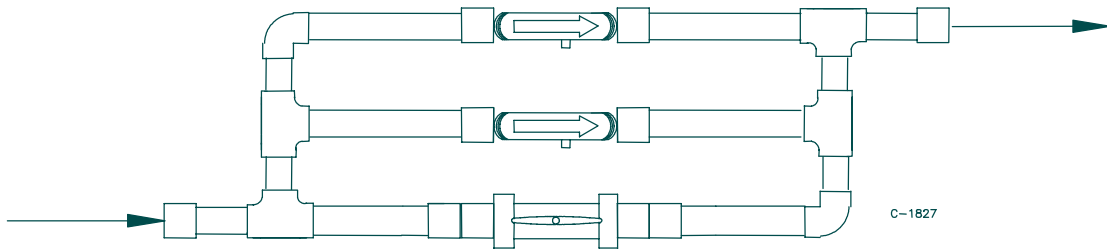

Fig. 7.1 Hydrocharger Bank

Note: Hydrocharger shown above is for a typical filter systems.

Larger or smaller filter units use same general arrangement, but may use more or less air injectors.

3. Begin flowing water through the filter(s) at the recommended service flow rate.
4. Upon reaching a stable service flow rate and pressure, begin closing the ball valve until all the hydrocharger venturi begins drawing air. This is indicated by either a whistling sound, or by being able to feel the air suction at the venturi inlet.

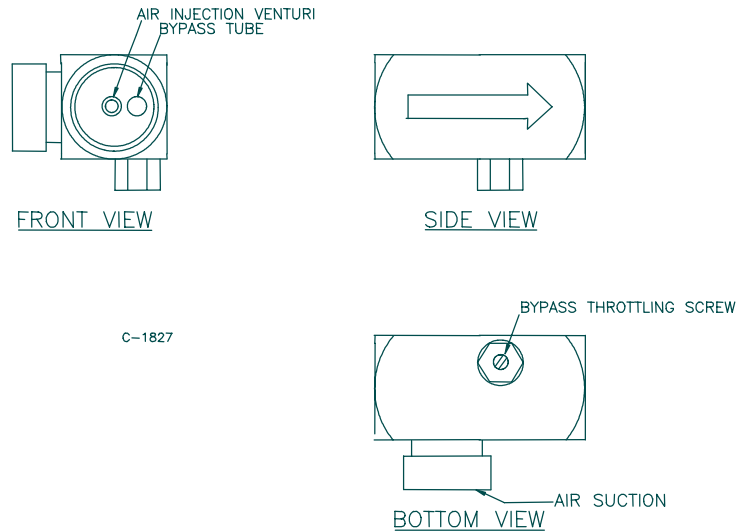

Fig. 7.2 Air Injector

5. Once air suction is detected, let the system stabilize at that point. Periodically monitor the effluent iron level, checking to see if the media bed is reducing the iron concentration down to an acceptable level.

Note: The chem free media, (which differs from all other filters), is most efficient operation occurs when the media is slightly "dirty" Once the system is in operation, care must be taken not to over backwash the chem free bed. If the bed is overcleaned, it may have to be run for a while to "dirty up" the bed to make the filter operate properly.

6. If the iron is not being adequately reduced, more water must be forced through the venturi tube. This is done by further closing the ball valve. Minor differences between hydrochargers can be adjusted by minor adjustments using the hydrocharger bypass throttling screw.
7. Once again, allow the filter to stabilise at this injection rate. Repeat the water tests in determine the effluent iron concentration.
8. Repeat steps 6 & 7 until the iron is being reduced down to an acceptable level.

## Section 8. Filter Operation 2850 Valve

### 8.1 Operating Conditions

For correct operation of the filter system, the minimum water pressure required is 30 psig, (206 kPa), in order for valve to operate effectively.

Caution: Water pressure is not exceed 100 psig, (690 kPa), water temperature is not to exceed 110°F, (43°C), and the unit can not be subjected to freezing conditions.

The manual bypass valve, (by others), must always be closed and the manual inlet and outlet isolation valves, (by others), open except during maintenance of the equipment.

### 8.2 Cycle Operation

The current position of the control valve can be confirmed by opening the control valve cover, and looking at the cycle cam position. Each cycle is completed at specific locations during the cam's rotation.

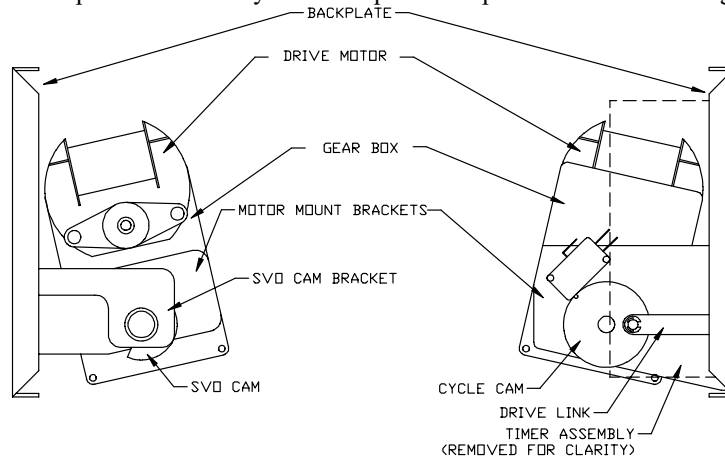
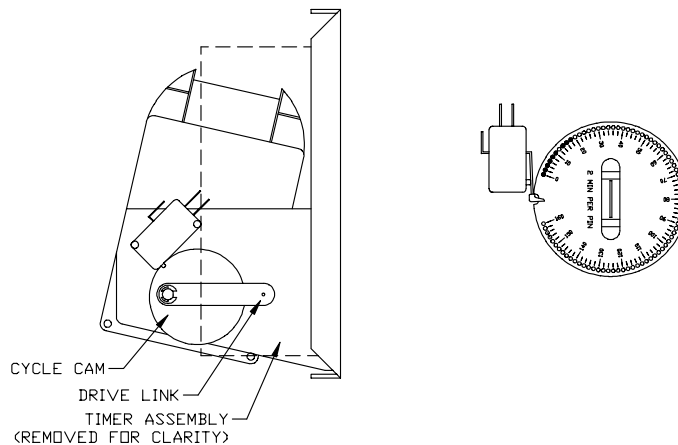

Fig. 8.1 Powerhead Schematic  
Powerhead shown with standard backplate

#### 8.2.1 Service Position

During service, water is directed into the top of the tank by the control valve and flows downward through the filter media, into the distribution, and out to service.

During service, the drive gear holds the drive link horizontal, with the piston withdrawn to its maximum length.



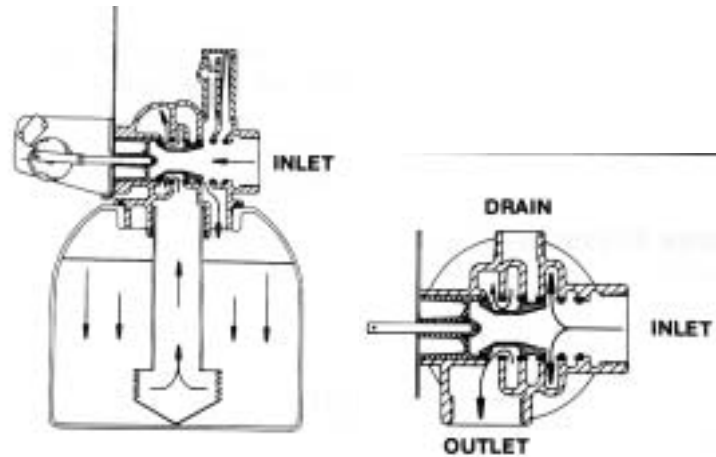

Fig. 8.2 Drive Motor Service Position, Program Wheel Locations & flow diagrams during Service

As the duration of the service run increases, the filter bed accumulates particulate, and becomes "packed", increasing the pressure drop across the unit. The pressure drop can be determined by inlet and outlet pressure gauges on the filter system. For all units except the carbon filter (which should be regenerated on time or volume), once the pressure drop reaches approximately 8 psi above the clean bed pressure drop, the filter requires regenerating. If pressure loss through the filter begins to effect normal flow, more frequent regenerations will be required.

### 8.2.2 Backwash Position

The regeneration procedure is performed automatically by the filter after the cycle controller is started. Each regeneration cycle consists of three steps, backwash, settle, and rinse.

During backwash, water is directed upwards through the filter and out to drain. This loosens the filter bed and cleans it thoroughly. The accumulated filtrate are flushed to drain. The backwash cycle has been factory preset to take place for 12 minutes (except for chem free unit which is 6 minutes).

The drive gear holds the drive link completely horizontal, 180° from the service position, with the piston rod fully inserted into the valve body.

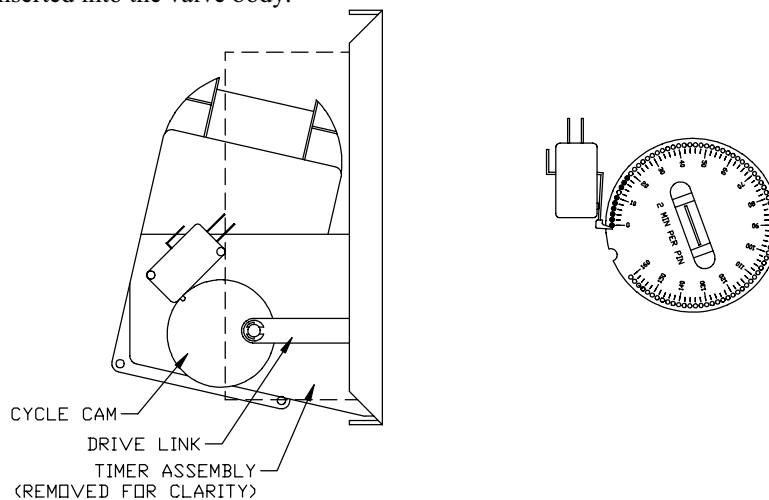

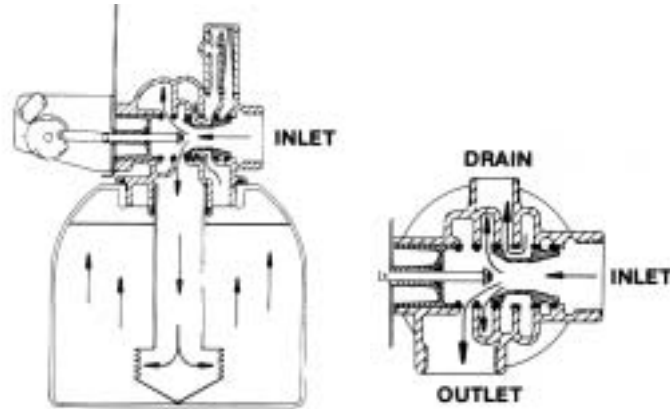

Fig. 8.3 Drive Motor Backwash Position, Program Wheel Locations and flow diagrams during Backwash

### 8.2.3 Settle Position

During the settle position, water is shut off completely through all ports. This cycle remains for two minutes before advancing into the rinse position.

When in the settle position, the drive link is rotated another 45° from the first settle position, until the drive gear stops with the drive link connection at the bottom of the drive gear, with the drive link at approximately 40° angle from the horizontal.

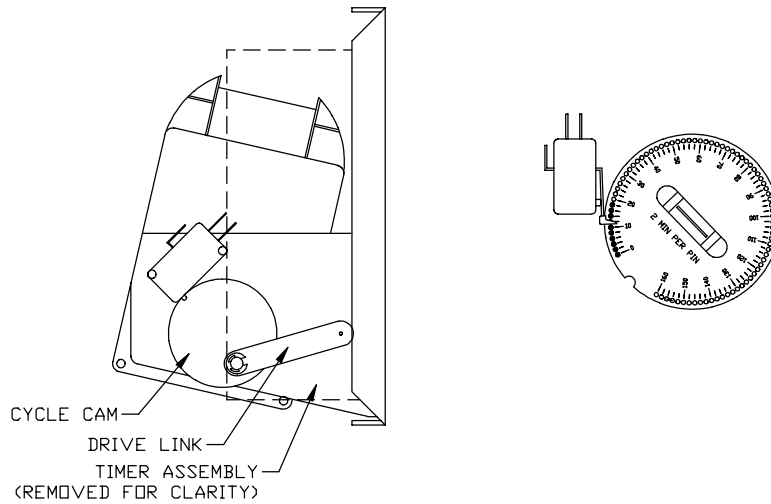

Fig. 8.4 Drive Motor & Program Wheel Location during Settle

### Position 4. Rinse

During rinse, water is directed downwards through the filter and out to drain. This reconsolidates the media bed and rinses any remaining particles in the media bed to drain.

When in the rinse position, the drive link is rotated another 5° from the settle position, until the drive gear stops with the drive link connection at the bottom of the drive gear, with the drive link at a 45° angle from the horizontal.

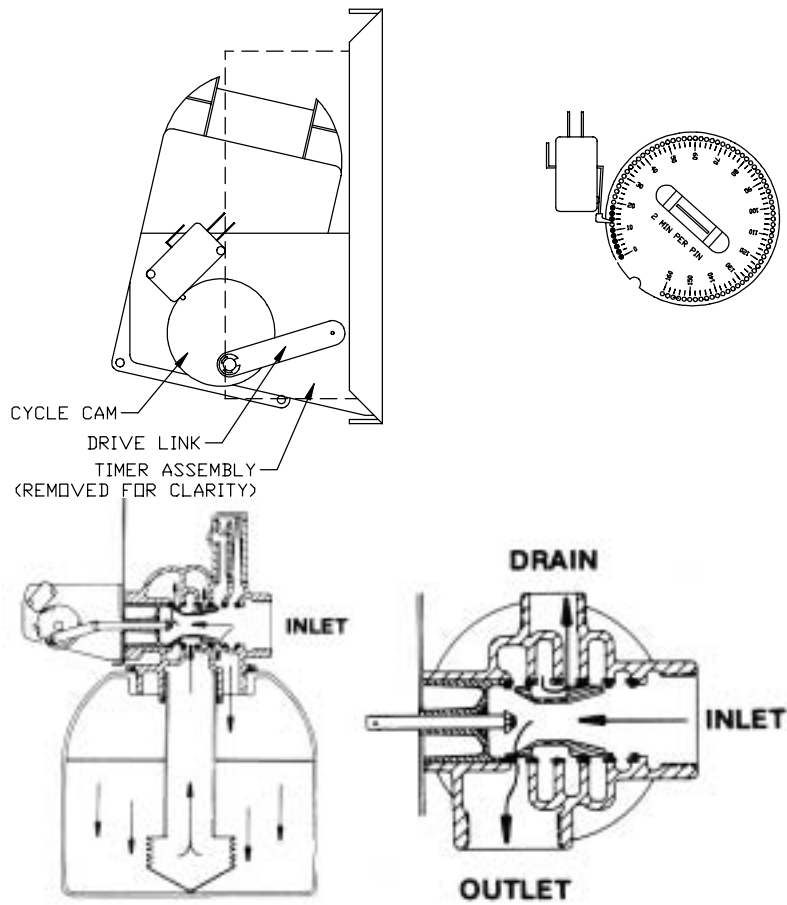

Fig. 8.5 Drive Motor Rinse Position, Program Wheel Locations & flow diagram During Rinse



## Section 9. Filter Control

---

The standard filter controller is a mechanical type controller, which automatically initiates the backwash sequence by one of three methods: calendar clock, volumetric meter, or pressure differential. All systems can be manually initiated by simply moving the manual regeneration knob clockwise. Only a slight turn is required to start the unit into regeneration. Remote meter initiated units should be manually initiated ONLY from the remote meter, which is again started by a slight clockwise movement on the remote meter timer knob. Multiple unit systems that are interlocked are sequentially regenerated with the lead unit automatically initiating the next unit. In the U.S., all calendar clock initiated units are not interlocked. Regeneration times must be staggered to prevent more than one unit going into regeneration at the same time.

Other control systems are available, such as the ET digital timer, which can replace the standard mechanical controller; and the Systemax 2000 Digital Controller, which looks after the operation of up to three, (3), separate units; including giving visual indication of flowrates, time, and allowing operator control of method of initiation. *For information on configuring either the ET digital timer or the Systemax, please consult their service manuals.*

### 9.1 Calendar Clock

---

With calendar clock initiation, a 12 day repeating timer automatically initiates the regeneration sequence after a preset number of days during the 12 day cycle. The regeneration sequence is factory preset to occur at 1:00 AM on the day that regeneration is initiated by the clock. Once initiated, the cycle timer operates the control valve, advancing the valve into each position, and holding it there for a specific length of time. The interval between regenerations can be adjusted to suit each application, depending on the raw water quality. This time interval is adjustable, with a minimum regeneration sequence interval of one regeneration per day.

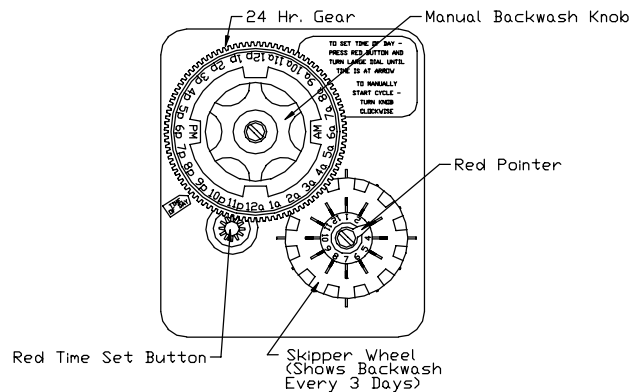

Figure 9.1 Calendar Clock

#### Setting the time of day:

- Press and hold the red button in to disengage the drive gear.
- Turn the large gear until the actual time of day is opposite the time of day pointer.
- Release the red button to again engage the drive gear.

#### Frequency of regeneration:

To set the frequency of regeneration, simply pull out the metal tabs on the skipper wheel on the days that you wish the filter to regenerate. For example, every 3rd tab has been extended in the illustration above, indicating that regeneration of that filter will take place every three, (3), days.

#### How to Adjust Regeneration Time:

1. Disconnect the power source.
2. Locate the three screws behind the manual regeneration knob by pushing the red button in and rotating the 24 hour dial until each screw appears in the cut out portion of the manual regeneration knob.
3. Loosen each screw slightly to release the pressure on the time plate from the 24 hour gear.
4. Locate the regeneration time pointer on the inside of the 24 hour dial in the cut out.
5. Turn the time plate so the desired regeneration time aligns next to the raised arrow.
6. Push the red button in and rotate the 24 hour dial. Tighten each of the three screws.
7. Push the red button and locate the pointer one more time to ensure the desired regeneration time is correct.
8. Reset the time of day and restore power to the unit.

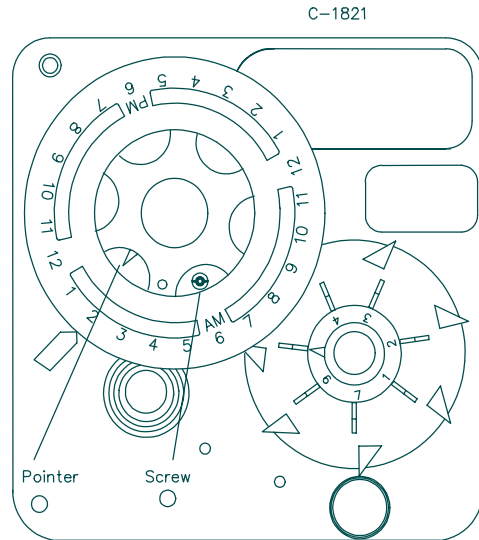

### 9.2 Volumetric Meter

The second method of regeneration initiation is by a volumetric meter which counts the volume of water as it passes through the filter during service. The meter is attached to a Fleck model 3210 control timer, by a rotating cable. The control timer has an adjustable volume dial on it, where the volume of water to pass through the meter between regenerations can be set. As the water flows through the flowmeter, the cable rotates, slowly moving the volume dial on the timer towards zero. Once the meter reaches zero, the remote meter immediately signals the cycle timer (standard unit) to begin the regeneration sequence. Once signalled, the cycle timer takes over for the duration of the regeneration cycle, controlling the regeneration sequence, just as in the calendar clock control method.

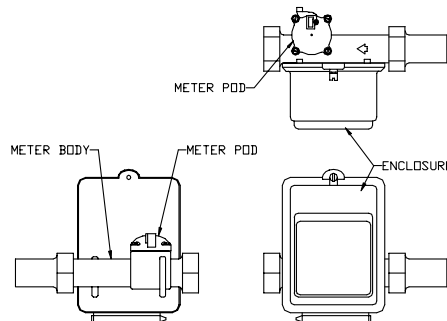

Fig. 9.2 Meter Details

### 9.3 Pressure Differential

The final method of backwash initiation is by pressure differential. A pressure differential switch is connected to the inlet and outlet sides of the filter. Once the pressure drop across the filter reaches a preset level, (usually approx. 8 to 10 psi), the pressure differential switch closes, immediately sending a signal to the control valve that backwash is required, which in turn starts the cycle timer to begin the regeneration sequence. It should be noted that the cycle timer must receive a signal from the pd switch for approximately six minutes before the cycle timer will begin the regeneration. Note: The pressure differential option is not available for activated carbon filters.

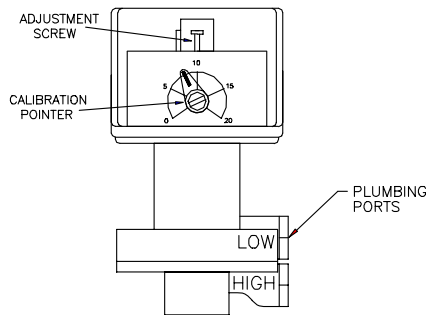

Fig. 9.3 Pressure Differential Switch

**How to Set Up the PD Switch:**

- Regenerate the filters to ensure the bed is clean.
- Put filters into service at the appropriate service flowrate.
- Remove the top cover from the P.D. switch.
- Set the calibration dial pointer to zero (0).
- Adjust the adjustment screw until the P.D. switch clicks. This adjustment compensates for the clean bed pressure loss. The common and normally open contacts on the P.D. switch are now closed.
- Now set the calibration dial pointer to the desired set point. The setting now indicated by the pointer is the pressure drop increase required (due to the bed getting "dirty") to initiate the filter regeneration.

**9.4 Regeneration Cycle Timer**

The cycle timer controls the operations of the valve during the regeneration sequence by incorporating a series of switches, which are opened and closed in a specific order to control the movement of the valve drive motor at certain times. This is accomplished by the cycle timer rotating a program wheel. In this program wheel, there are holes spaced so that each hole takes two minutes to pass by. By inserting pins into these holes, and having the switches depressed by these pins as the program wheel rotates, the switches can be depressed in a specific order. The regeneration cycle timer is illustrated below. Note: you can tell if the motor is running by looking at the "viewport" located on the motor.

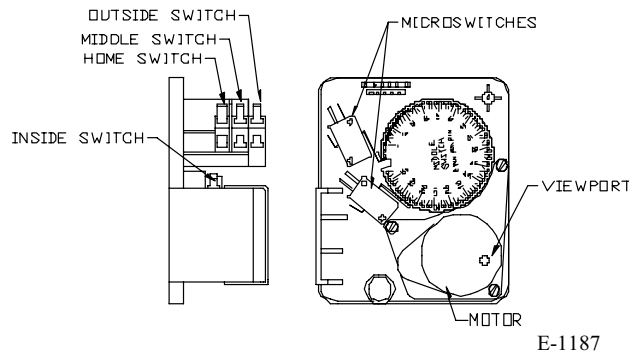

E-1187

Figure 9.4 Regeneration Cycle Timer

The standard filter control timer uses only the home, inside, and middle switches, with the outside switch being used only in custom applications. When certain switches in the control valve are closed simultaneously, the timer allows the valve drive motor to rotate, moving the piston to certain positions during the backwash sequence.

### 9.5 Regeneration Program

The regeneration cycle program on your filter has been factory pre-set. Typical cycle times are 10 minutes backwash, 2 minutes settle, and 6 minutes rinse. It should be noted however, that these cycle times may be lengthened or shortened to suit local conditions.

The pins on the program wheel determine the length of each cycle. Each pin represents two minutes of cycle time. The length of each cycle is either the number of pins (for backwash or fast rinse) or the number of holes (for settle). Please note that, when one set of pins is moved, it may affect the cycle time of other cycles unless other pins are also adjusted accordingly.

NOTE: Ensure pins for inside switch, (if required), do not extend far enough to cause interference with lower gear.

### 9.6 Changing the Regeneration Times

- To expose cycle program wheel, grasp the timer in upper left hand corner and pull, releasing snap and swinging timer to the right.
- To change the regeneration cycle program, the program wheel must be removed. Grasp the program wheel and squeeze protruding lugs toward centre, lift program wheel off timer (switch arms may require movement to facilitate removal).
- Add or remove pins in the backwash or rinse cycles in order to lengthen or shorten the cycle times. See figure 9.5 for factory preset pin settings.
- Make certain all electrical wires locate above snap retainer post when closing the timer assembly.

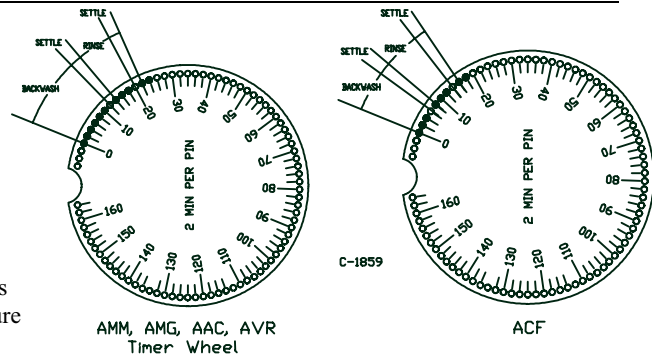

Fig. 9.5 Preset Pin Settings

## Section 10 Filter Trouble Shooting Guide

<b><u>PROBLEM</u></b>	<b><u>POSSIBLE CAUSE</u></b>	<b><u>REMEDY</u></b>
No water flowing to service.	A. Inlet and/or outlet isolation valves closed.	A. Open isolation valve(s).
	B. Unit unplugged during last regeneration.	B. Plug unit in, and return unit to service position.
	C. Packed media bed. This would be indicated by high pressure on inlet and low pressure on outlet.	C. Regenerate unit continuously until backwash effluent water runs clear to the drain.
Untreated water passing out to service.	A. By-Pass valve either partially open or not sealing.	A. Inspect bypass valve position and seal, replace or repair if necessary.
	B. Insufficient regeneration frequency and/or times.	B. Increase regeneration frequency and/or backwash time.
	C. Service flowrate exceeding maximum allowable rate.	C. Confirm service flowrate does not exceed recommended rate. Reduce if necessary.
	D. Broken or leaking distribution.	D. Inspect distribution, replace if necessary. Check O-ring between distribution riser tube and valve.
	E. Insufficient chemical injection, (manganese greensand filtration only), or air injection, (chemical free filtration only).	E. Increase dosage rates / air suction, (see section 7 for details on injection).
	F. Varying influent water quality	F. Confirm water quality through specific water analysis.
	G. Leak or crack in control valve seals. Particles partially jamming control valve.	G. Inspect seals, for damage and/or interference; replace if necessary.
	H. Have raw water bypass piston or no raw water bypass piston assembly failed.	H. Raw water bypass piston assemblies have white end plugs. No raw water bypass assemblies have black end plugs. Inspect piston & seals. Lubricate and/or replace internals if required.
Control valve fails to regenerate unit.	A. Loss of power to control valve.	A. Inspect power supply, ensure that control valve is powered and all connections are correct.
	B. Drive motor and/or timer assembly not receiving power.	B. Check continuity of wiring for shorts, breaks, etc.
	C. Drive gears and/or motor binding in gearbox.	C. Check motor and gear box, ensure that they run smoothly.
	D. Control valve piston jammed in valve body due to foreign material in valve body.	D. Remove piston, clean piston and seal/spacer assembly with water, and lubricate. Replace seals & spacers if required.
	E. Broken or shorted microswitch.	E. Check microswitches for continuity, replace damaged switch.

Control valve continuously cycles unit.	A. Broken or shorted microswitch.	A. Check microswitches for continuity, replace damaged switch.
Water flows to drain continuously.	A. Inadequate sealing of seals due to foreign material trapped in valve body.	A. Remove Piston, inspect seals and spacers, flush with water.
	B. Damaged and/or broken seals or spacers	B. Replace damaged and or broken seals or spacers.
	C. Unit unplugged during last regeneration.	C. Plug unit in, and return unit to service position.
Media flowing out though service.	A. Broken distributor	A. Replace distribution
<b>(Treated Water Regeneration Only)</b>		
No supply/raw water available during service.	A. Inlet diaphragm valve installed incorrectly.	A. Inspect inlet piping, confirm proper locations for treated water regeneration diaphragm valves. Reinstall in correct locations if required. Check pressure source to the SVO. Ensure it is a continuous pressure supply equal to the max. pressure the filter is subjected to.
No treated water supply available during regeneration.	A. Treated Water Supply diaphragm valve installed incorrectly.	A. Inspect inlet piping, confirm proper locations for treated water regeneration diaphragm valves. Reinstall in correct locations if required. Ensure it is a continuous pressure supply equal to the max. pressure the filter is subjected to.
Treated water regeneration diaphragm valves not operating properly	A. Treated Water Supply diaphragm valve installed incorrectly.	A: Inspect tubing connections to diaphragm valves (see section 4). Ensure it is a continuous pressure supply equal to the max. pressure the filter is subjected to.
	B. Diaphragm valves sticking	B. Inspect diaphragm valves internals and repair or replace as necessary.
<b>(Manganese Greensand Filters Only)</b>		
Pink colour in filtered water.	A. Potassium permanganate dosage too high.	A. Reduce chemical injection pump dosage rate, and/or dilute solution concentration.
High iron and/or manganese content in filtered water.	A. Filter run length too long	A. Increase regeneration frequency and/or backwash time.
	B. Potassium permanganate dosage too low.	B. Increase chemical injection pump dosage rate, and/or increase solution concentration. Media

		bed may require soak procedure again.
Manganese content in filtered water higher than raw water.	A. Potassium permanganate dosage slightly high.	A. Reduce chemical injection pump dosage rate, and/or dilute solution concentration.
<b>(Chemical Free Filters Only)</b>		
Hydrocharger will not draw air.	A. Hydrocharger plugged.	A. Clean hydrocharger.
	B. System operating pressure too high.	B. Lower operating pressure or contact USF representative about air draw system that operates at higher pressures.
No filtered water exiting filter.	A. Media has solidified.	A. Remove existing tank assembly, and replace with replacement tank and media. Contact your supplier for more information.
High iron content in filtered water.	A. Best results with the chem free filters occur when the media bed is slightly "fouled"	B. Reduce the regeneration frequency.

## Section 10.2 Seal and Spacer Replacement

1. Remove electrical plug from outlet, turn off water supply to valve and relieve water pressure.
2. Remove control box cover.
3. Disconnect the brine line, from the injector housing to the brine valve (if your unit has timed brine tank fill).
4. Remove the two cap screws that hold the back plate to the valve.
5. Grasp the back plate on both sides and slowly pull end plug and piston assembly out of the valve body, (see Fig. 1) and lay aside.

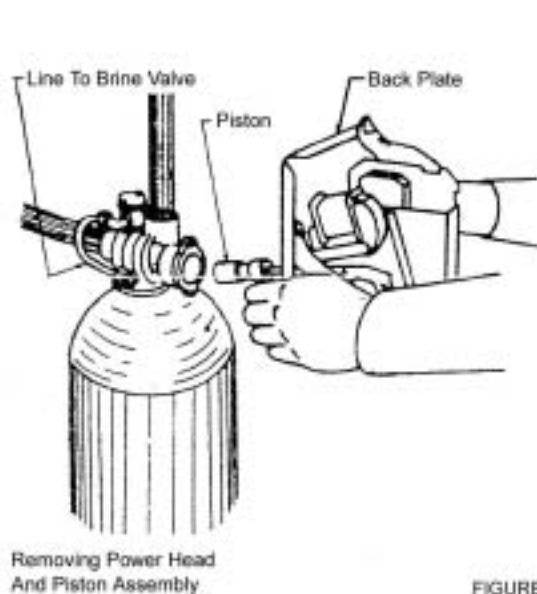

FIGURE 1

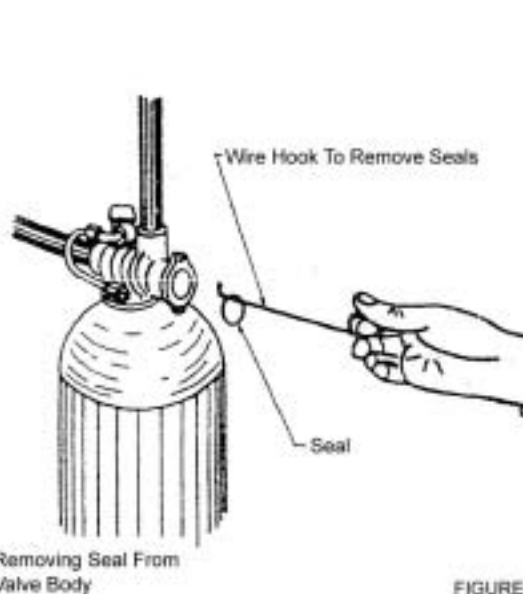
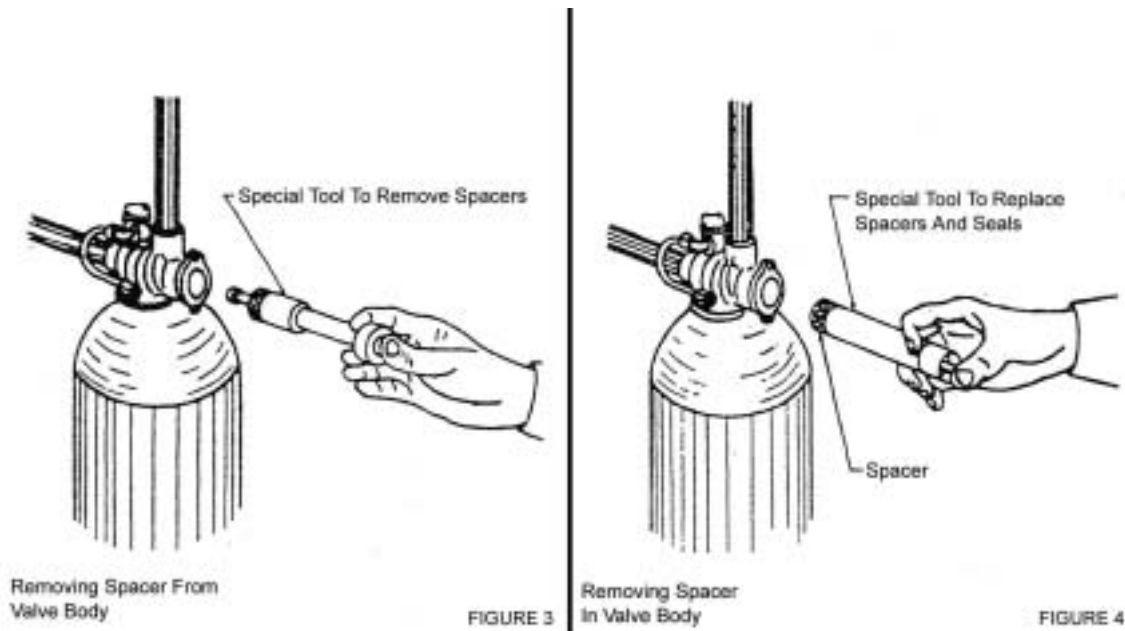

FIGURE 2

6. Remove the seal first using the wire hook with the finger loop (see Fig. 2)
7. The spacer tool (sue only for removing the spacers) has three retractable pins, retained by a rubber ring, at one end; they are retracted or pushed out by pulling or pushing the center button on the opposite end.
8. Insert the pin end of the spacer tool into the valve body with the pins retracted (button pulled back). Push the tool tight against the spacer and push the button in, (see Fig. 3). When the button is pushed in, the pins are pushed out to engage the ¼ dia. Holes in the spacer. Remove the tool from the valve body. The spacer will be on the end. Pull the center button back, the pins will be retracted and the spacer can be removed from the spacer tool.



9. Alternately remove the remaining seals and spacers in accordance with steps No.6 and 8.
10. The last or end spacer does not have any holes for the pins of the spacer too to engage, therefore if the end spacer does not come out on the first try, try again using the wire hook with the finger loop.
11. To replace seals, spacers and end ring use special tool with the brass sleeve on one end. This is a double-purpose tool. (See Fig. 4.) The male end acts as a pilot to hold the spacers as they are pushed in=to the valve body and the brass female end is used to insert the seals into the valve body.
12. To restuff a valve body first take the end ring, (the plastic or brass ring without holes), then with your thumb press the button on the brass sleeve end, the large dia. Inner portion is now exposed. (See Fig. 4.) Place the end ring on this pilot with the lip on the end ring facing the tool, and push the tool into the valve body bore until it bottoms. While the tool is in the valve body take a seal and press it into the inside diameter of the exposed brass female end. (See Fig. 5.)
13. Remove the tool, turn it end for end and insert it into the valve body bore. While holding the large dia. Of the tool, slide it all the way into the valve body bore until it bottoms, then push the center button to push the seal out of the tool and leave it in place in the valve body. (See Fig. 5.)
14. Remove the tool from the valve body and push the center on the brass female end to expose the pilot on the opposite end. Place a spacer on this end and insert the spacer and tool into the valve.



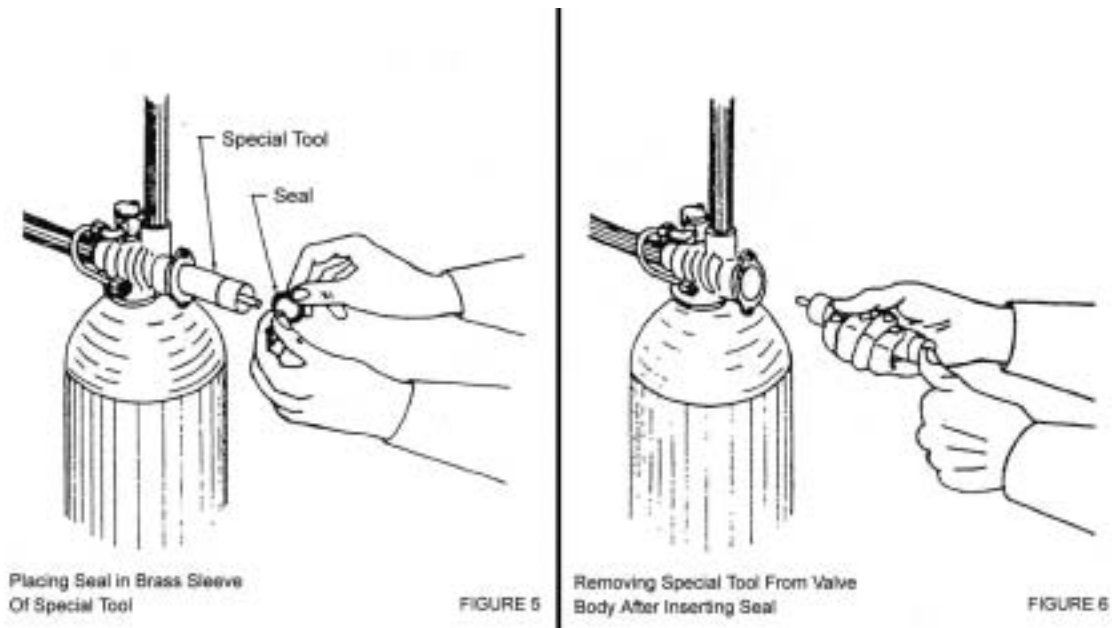

15. While the tool is still in the valve, press another seal into the inside diameter of the exposed brass sleeve end.
16. Remove the tool, turn it end for end, and insert it into the valve body bore.
17. Alternately repeat steps No. 13 and 14 until all seals and spacers have been pushed into the valve. (See valve cross section of your valve.)
18. Place silicone lubricant on the piston and inside the valve.
19. Hold the back plate with one hand and guide the piston into the valve body with the other hand, then grasp the back plate on both sides and slowly push the piston assembly and end plug assembly into the valve. (See Fig. 1.)
20. Replace the two cap screws to hold the back plate to the valve and tighten securely.
21. Connect the brine line from the injector housing to the brine valve, (if your unit has timed brine tank fill).
22. Set the time of day dial to the correct time.
23. Replace the electrical plug in the outlet.
24. Turn on water supply.
25. Cycle control and check for proper function.
26. Check by-pass valve.

## Piston Assembly Replacement

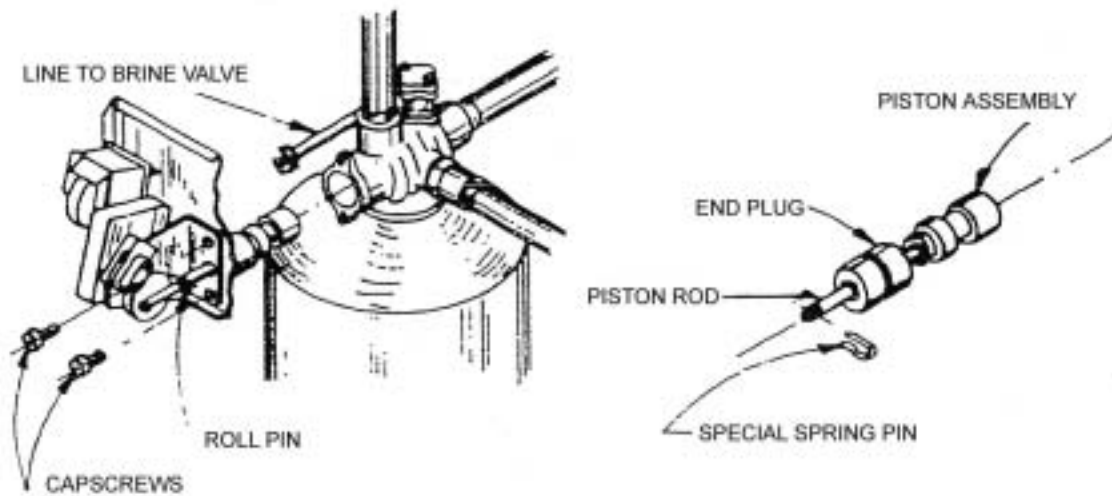

1. Turn off water supply to the valve and relieve water pressure.
2. Cycle the valve until the piston is in the service position (piston rod all the way out).
3. Remove electrical plug from outlet.
4. Remove two cap screws holding back plate to valve.
5. Disconnect brine line, from injector housing to brine valve, at the brine valve (if your unit has timed brine tank fill).
6. Grasp the back plate on both sides and slowly pull end plug and piston assembly out of the valve body.
7. Pull out the roll pin or special spring pin that connects the piston rod to the connecting link and remove the complete end plug and piston assembly.
8. Take the new piston assembly as furnished, pass through the back plate and motor support and fasten piston rod to the connecting link with special spring pin.
9. Inspect the inside of the valve to make sure that all seals and spacers are in place.
10. Spread or spray silicone lubricant on the piston and on the seals inside the valve body.
11. While holding the back plate on the side with one hand, start the piston into the valve by guiding it with the other hand. Then grasp the back plate on both sides and slowly push the piston and then the end plug into the valve.
12. Replace the two valve body cap screws and tighten.
13. Connect the brine line to the brine valve, if used.
14. Place electrical plug in outlet.
15. Set time of day.
16. Turn on water supply.
17. Cycle control and check for proper function.
18. Make sure that valve is in service position (piston rod all the way out).
19. Check by-pass valve.

	Seal & Spacer Stuffer Part Number	Seal & Spacer Puller Part Number
2750 Valve	11098	13061
2850 Valve	16516	17623
2900 Valve	12683	12682
3150 Valve	12683	12682
3900 Valve	12683	12683
9000 Valve	12763	13061
9500 Valve	16516	17623

\* Other tools include: #12874 Seal Hook  
#13644 Molex Pin Tool

---

**PRESSURE VESSEL  
LIFTING,  
HANDLING &  
INSTALLATION  
INSTRUCTIONS**



**STRUCTURAL**  
**PRESSURE VESSELS**

---

**Contents** **Page**

Receiving .....	3
Basic Handling Rules .....	4
Approved Lifting Methods .....	8
Installing Pressure Vessel with Fiberglass Base .	10
Installing Pressure Vessel with I-Beam Base ....	12
Flange Cover Assembly and Torque Ratings .....	18
Side Flange Support Strength .....	20
UV Protection .....	21
Vacuum Protection Flex Connectors .....	22
Flexibility in Piping .....	23
Vertical Base Removal and Replacement .....	25
Install the New Base .....	27

**RECEIVING**

Pressure vessels from Structural North America are protected during shipment by custom-size cradle skids. All pressure vessels are placed horizontally on the skid.



A pressure vessel with an integral Fiberglass base should be placed in a vertical upright position before removing its skid.

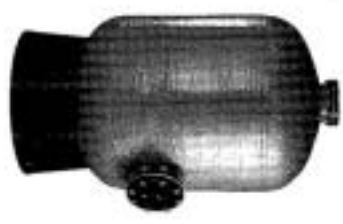

A pressure vessel with an I-Beam base to be attached, should remain in a horizontal position until ready to attach legs.



At the time of delivery, inspect both the inside and outside of the pressure vessel. If damage has occurred, notify the carrier immediately or prior to signing the acceptance form. Damage occurring during shipment is the responsibility of the carrier. Any damage claims must be pursued promptly by the receiving party with the delivering carrier.

## BASIC HANDLING RULES

This guide is designed to help install pressure vessels properly. Improper handling or installation can result in damage or pressure vessel failure.



**1.** If pressure vessels are being stored prior to installation, leave them in their protective shipping skid until ready to install.



**2.** Never roll or slide a pressure vessel on its side.

4

**3.** Never drop a pressure vessel or allow hard impact or abrasion of the pressure vessel from contact with walls, partitions, tools, or equipment.



**4.** Lift the pressure vessel using a crane or forklift and the approved methods shown on pages 8 and 9.

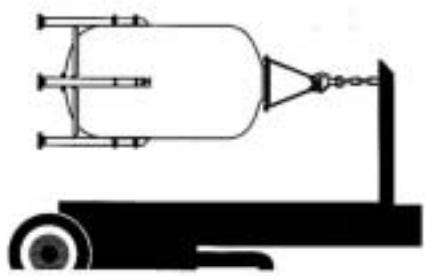

5

**BASIC HANDLING RULES**  
continued



**5.** Operators of hoist equipment must follow **proper rigging** procedures.



**6.** Avoid use of hooks or equipment on the **inside** of the pressure vessel.

**7.** Set rigging to lift from the **outside**, otherwise the lining could be damaged.

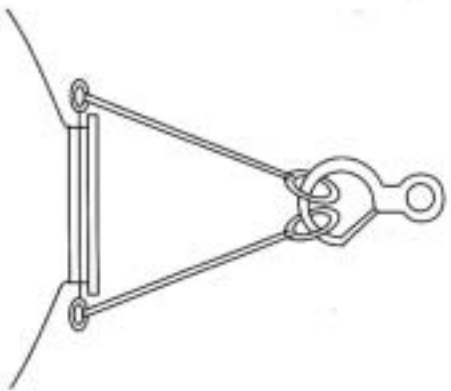

**8.** Never fasten cables or chains around pressure vessel. Use canvas or nylon straps to avoid damage to the flange area.



**6**

**7**

## APPROVED LIFTING METHODS

### By Flange

The empty pressure vessel is lifted by placing a user-supplied, webbed nylon reinforced sling, Percec, or rated steel cable around the top flange. Sling must be rated at minimum of 10,000 lbs. (4,500 kg).  
**CAUTION:** Steel cable must have protective coating to prevent scratching of the flange's Teflon coating.

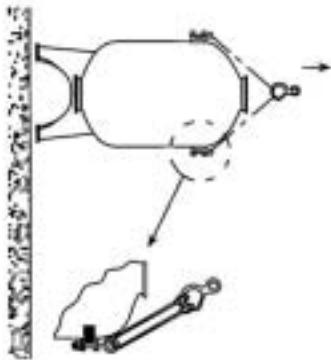
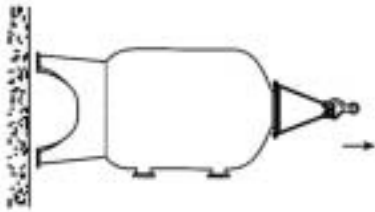

### By Lifting Lugs

Both lifting eyes to the pressure vessel's integral lifting lugs (if specified) and attach a rated (10,000 lbs.; 4,500 kg) steel cable to the eyes.

**CAUTION:** Protect the flange's protective coating from being scraped by the cables.

### By Lift Strap

Attach a 1/2" (12.7 mm) thick, user-supplied steel lift strap to the top flange, using at least two (2) bolts per side. Then connect to a rated (10,000 lbs.; 4,500 kg min.) eyebolt and cable.

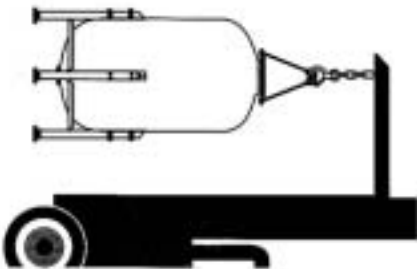
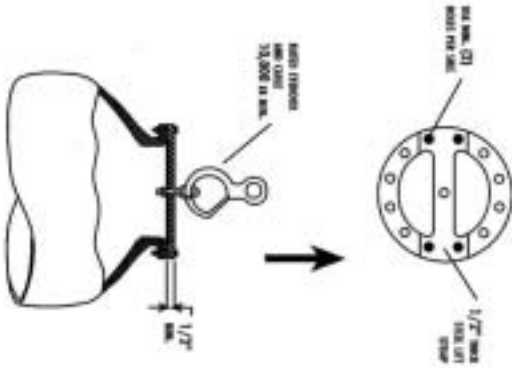

### By Forklift

When unloading and installing a pressure vessel with I-Beam base, the pressure vessel may be lifted using a forklift unit.

**CAUTION:** Use only the approved sling rig methods; do not place chain or cable around or inside pressure vessel. Be sure forklift is designed to handle the pressure vessel's weight at the height the pressure vessel is to be lifted above the floor.



## INSTALLING PRESSURE VESSEL WITH FIBERGLASS TRIPOD OR SKIRT BASE

To prevent breakage of the Fiberglass base, the following procedure is recommended for handling, unloading, and installing these pressure vessel types.

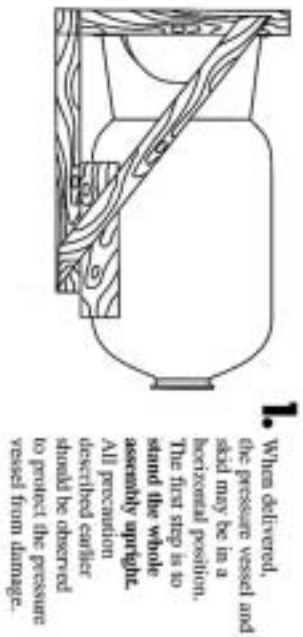

**1.** When delivered, the pressure vessel and skid may be in a horizontal position. The first step is to stand the whole assembly upright. All precaution described earlier should be observed to protect the pressure vessel from damage.

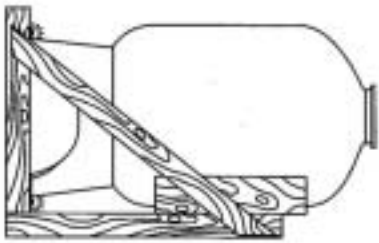

**2.** When the pressure vessel and skid are upright, remove the bag bolts which are holding the skid to the base of the pressure vessel.



**3.** Using one of the approved lifting methods shown on pages 8 & 9, lift the pressure vessel from the skid, and remove the skid.

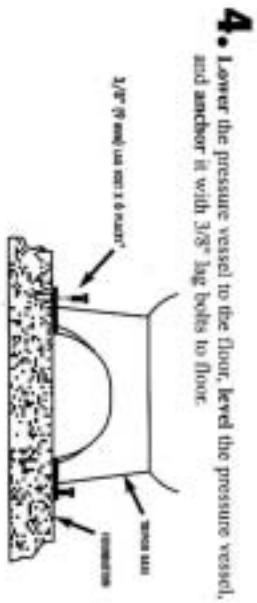

**4.** Lower the pressure vessel to the floor, level the pressure vessel, and anchor it with 3/8" lag bolts to floor.

\* 3/8" lag bolts are not to exceed 16 inches in length and to remain within 3" of floor.

## INSTALLING PRESSURE VESSEL WITH I-BEAM BASE

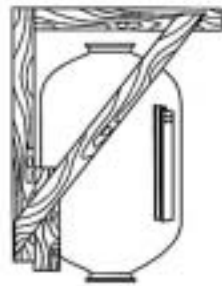

**1.** When delivered, the pressure vessel and skid will be in a horizontal position. Leave pressure vessel on skid and remove the four legs which were temporarily attached for shipment.

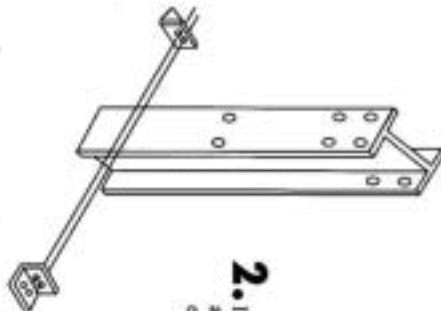

**2.** Install a pair of 2" (51 mm) long angle brackets to the bottom of each of the legs.



**3.** Attach a leg pad to the angle brackets on each leg.

12

**4.** Install the 7.3/4" (197 mm) long cross brace brackets to the legs, with the slotted surface up.



**5.** Lift the pressure vessel from the skid and into a full upright position. Keep the pressure vessel suspended until remaining hardware is attached and secured.



13

## INSTALLING PRESSURE VESSEL WITH I-BEAM BASE continued

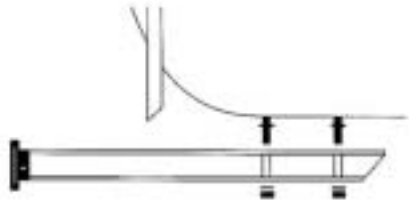

**6.** Attach the legs, inserting a spacer within the I-beam web at each bolting point. See page 17 for details.

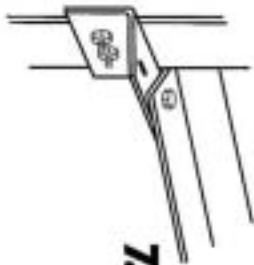

**7.** Attach the cross braces on all four sides.

**8.** Tighten all bolts, position pressure vessel over supporting surface and gently lower pressure vessel into place. (Refer to local code requirements.)

14

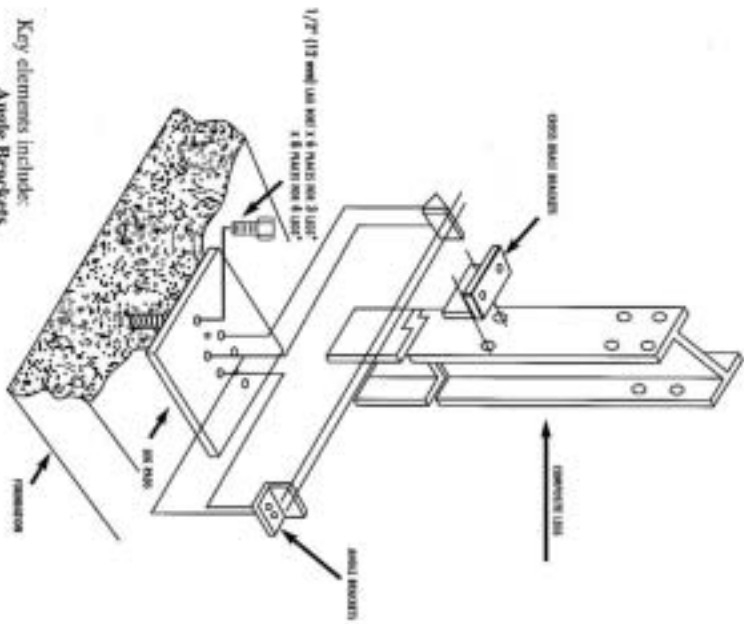

- Key elements include:
- Angle Brackets
  - Leg Pads
  - Cross Brace Brackets
  - Cross Braces
  - Composite Legs

\* Refer to project contract or manual. If a supplier has no manual or details refer to project manual or specs.

15

## INSTALLING PRESSURE VESSEL WITH I-BEAM BASE continued

9. Adjust the internal nuts to level the leg.

10. DO NOT raise or lower the pressure vessel by pivoting on the leg base. Permanent damage will result.

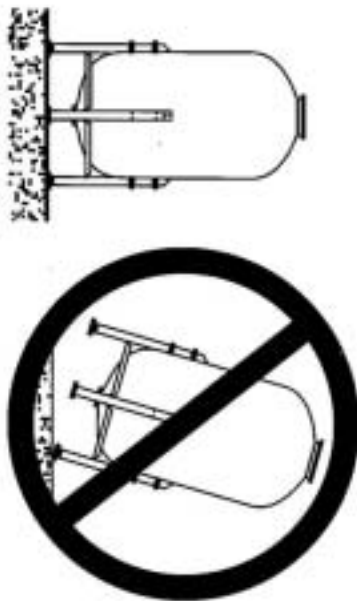

2.0 in. for 24", 30", and 36" dia. pressure vessels  
4.0 in. for 42", 48", and 60" dia. pressure vessels

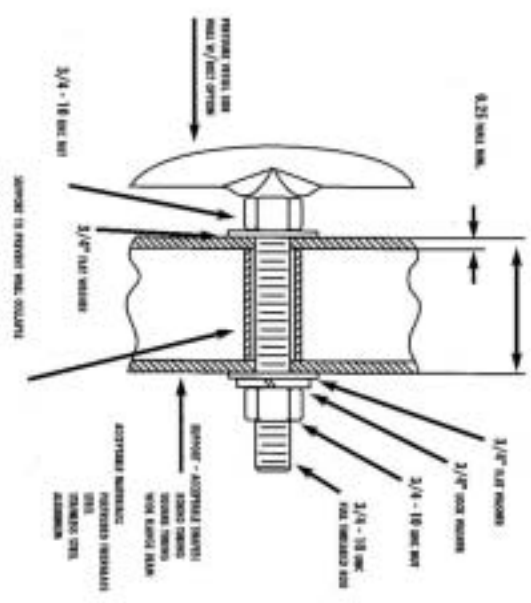

In connecting the I-Beam legs to the integral bolts on the pressure vessel, the hardware sequence is:

- Nut
- Flat Washer
- Leg with Spacer
- Flat Washer
- Lock Washer
- Nut

## FLANGE COVER ASSEMBLY AND TORQUE RATINGS

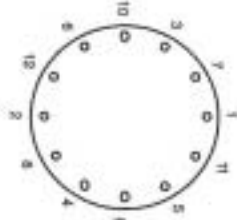

12-bolt Flange Cover (6", 152 mm Flange)  
Tightening Sequence for 3/16" (7.9 mm)  
Stainless Steel Bolts  
Torque to 11 ft.-lbs. (15 NM)

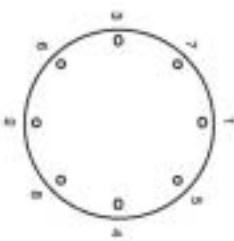

8-bolt Flange Cover (4-1/2", 114 mm Flange)  
Tightening Sequence for 3/4" (19 mm)  
Stainless Steel Bolts  
Torque to 130 ft.-lbs. (176 NM)

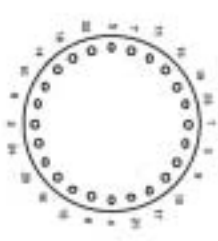

24-bolt Manway Flange Cover  
24" (610 mm) Dia. Pressure Vessels  
Tightening Sequence for 3/8" (9.5 mm)  
Stainless Steel Bolts  
Torque to 18 ft.-lbs. (24 NM)

## For All Vessels Larger than 24" Diameter

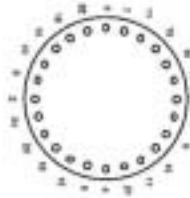

24-bolt Manway Flange Cover  
Tightening Sequence for 1/2" (12.7 mm)  
Stainless Steel Bolts  
Torque to 45 ft.-lbs. (61 NM)

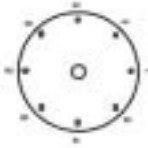

8-bolt, 4" (102 mm) ANSI Flange  
Tightening Sequence for 5/8" (15.9 mm)  
Stainless Steel Bolts  
Torque to 90 ft.-lbs. (122 NM)

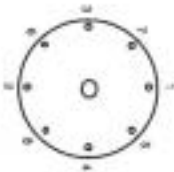

8-bolt, 6" (152 mm) ANSI Flange  
Tightening Sequence for 3/4" (19 mm)  
Stainless Steel Bolts  
Torque to 130 ft.-lbs. (176 NM)

### TORQUE CHART

5/16" (7.9 mm)	5/8" bolts = 11 ft. lbs. (15 NM)
3/8" (9.5 mm)	5/8" bolts = 18 ft. lbs. (24 NM)
1/2" (12.7 mm)	5/8" bolts = 45 ft. lbs. (61 NM)
5/8" (15.9 mm)	5/8" bolts = 90 ft. lbs. (122 NM)
3/4" (19 mm)	5/8" bolts = 130 ft. lbs. (176 NM)

## SIDE FLANGE SUPPORT STRENGTH

Valves, piping and hardware all contribute to the weight loads put on side flanges.

Side flanges are rated for a bending torque,  $M$ , maximum of 50 ft. lbs. This means that:

$$d \times F \text{ must be } \leq 50 \text{ ft. lbs.}$$

For  $d = 1$  ft.,  $F_{\text{max.}} = 50$  lbs.

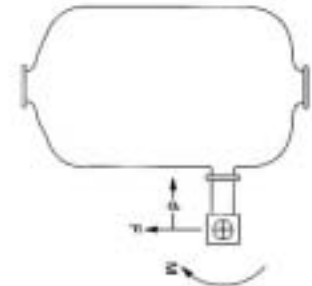

Where  $d$  = distance in feet from flange face to center of the load

(such as a valve)

$F_{\text{max.}}$  = maximum support load in pounds

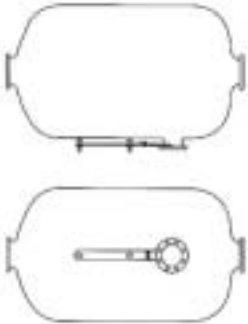

To support greater loads, a support kit, No. 12647, is available for upper side flanges only. With the support kit, the side flange is rated for a bending torque,  $M$ , of 300 ft. lbs.

Thus, for  $d = 1$  ft.,

$$F_{\text{max.}} = 300 \text{ lbs.}$$

**Note:** Lower side flanges not available when upper side flange support kit is used.

20

## UV PROTECTION

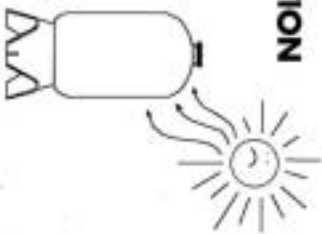

### Painting a Composite Pressure Vessel for UV Protection

1. Wash the pressure vessel with detergent and water, using a scrub brush. Use the brush actively over the pressure vessel surface to remove oil and grime.
2. Rinse the pressure vessel several times with water to remove soap residue and let dry.
3. Using a clean rag wetted with acetone, rinse the pressure vessel thoroughly with the acetone. Make sure that the rag does not become gritty, and use as much acetone as is practical to perform a "wet rinse" over the pressure vessel surface. **NOTE:** Acetone is extremely flammable. Should not be inhaled. Requires use of gloves.
4. Spray paint or paint with a roller or brush.
5. A 100% interlockester acrylic latex enamel is preferred. The paint has a good adhesion and will not chalk. This is a one-step paint with water clean-up. The 100% acrylic latex enamel can be purchased at a paint store.
6. Coat the UV areas first, such as the top of the pressure vessel and the side, where sun rays directly hit the pressure vessel.
7. A light-colored, pigmented paint is preferred. White paint is best.

21

## VACUUM PROTECTION FLEX CONNECTORS

The pressure vessel is rated for an internal negative pressure of 5" Hg (17 Pa) vacuum below atmospheric. If negative pressure could ever exceed 5" Hg (17 Pa), an adequate vacuum breaker must be installed between the pressure vessel inlet and any valves, as shown here.

System connections to the pressure vessel must accommodate vertical expansion between side, top, and bottom openings. Either flexibility in piping, as shown on pages 22 and 23, or flex connectors as shown here, are recommended.

Flex connectors and Vacuum Breakers are available from Structural North America. Please consult SNA accessory catalog. Contact Customer Service: Tel: 440-286-4116, Fax: 440-286-4351

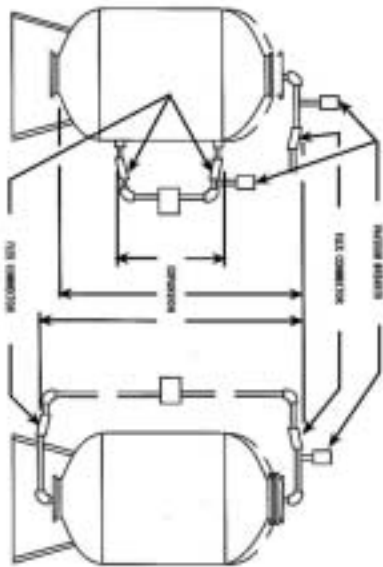

22

## FLEXIBILITY IN PIPING

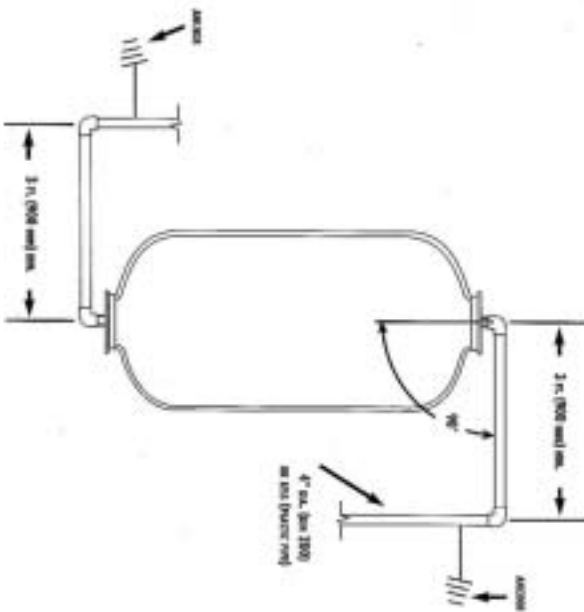

An effective alternative to flex connectors uses the inherent flexibility of right angle system design. By calculating the amount of cantilever over-hang needed to absorb the torsional effort created by the pressure vessel's vertical movement, it is possible to build the needed flexibility right into the piping system. This can be done with both top/bottom and side flow piping setups.

23

## FLEXIBILITY IN PIPING (continued)

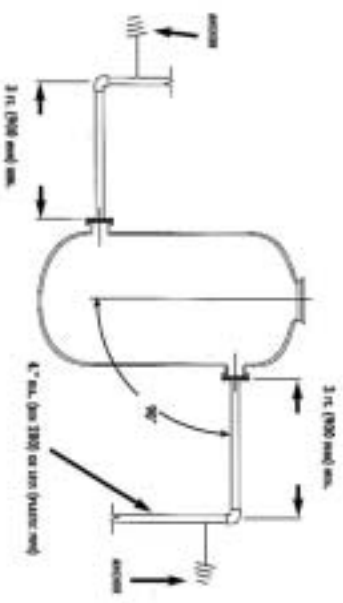

The figures shown here are the acceptable minimum for the pressure vessel at its rated pressure of 150 psig. When using the pressure vessel at a lower pressure, the minimum pipe run length can be reduced, using this formula:

- Multiply pressure vessel pressure in psi x 36
- Divide above by 150
- Result is minimum span of horizontal piping in inches

For example, if the pressure vessel pressure is 120 psi:

- $120 \times 36 = 4,320$
- 4,320 divided by 150 = 28.8
- Minimum span of horizontal piping is 29 inches

## VERTICAL BASE REMOVAL AND REPLACEMENT

FOR:

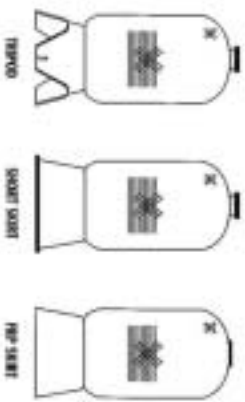

### REMOVAL KIT

A kit (#11644) with the required tools and instructions is available for purchase with the replacement base. The kit consists of wooden wedges (2), saw blades (3) with handle, adhesive (Bostic 1000), gloves, safety glasses and a rubber hammer.

### REMOVAL

To remove the original base, the pressure vessel must be empty and in the horizontal position. The pressure vessel must be lying on a protective material, such as cardboard, to protect it.





## VERTICAL BASE REMOVAL AND REPLACEMENT (continued)

1. Drive a wooden wedge between the pressure vessel and the base with the rubber hammer to create an opening to insert the saw blade. If necessary, use the second wooden wedge to make an opening for the saw blade. Have the saw blade teeth toward your hand so that you cut the adhesive with a pulling motion rather than a pushing motion. Use extreme caution to avoid injury when performing this step.



NOTE: Use extreme caution to avoid damaging fibers. If fibers are damaged, pressure vessel must not be used.

2. As the adhesive is being cut, the wedges must be moved (around the outer diameter of the base) to maintain a gap between the pressure vessel and the base to allow the saw blade to cut the adhesive without getting bound up.
3. After the base is removed, the heavy excess adhesive on the pressure vessel must be removed. Be careful. Do not damage exterior surface of the pressure vessel. It is not necessary to remove all of the old adhesive, but just the heavy excess to allow room for the fresh adhesive. Take your time, the base was installed for the life of the pressure vessel, so it may take a great deal of effort and patience to remove the old base without damaging the pressure vessel.

26

## INSTALL THE NEW BASE

1. You must first level the base on a concrete floor. The wooden wedges may need to be used under one or two of the tripod legs to get the base level if the floor is not level.

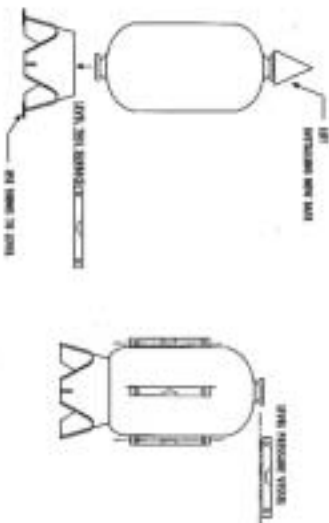

2. The adhesive is applied to the base (with a caulking gun) in a pattern that duplicates the area covered on the old base. The tip of the adhesive tube must be cut to apply the adhesive in a 1/4" diameter minimum.
3. The pressure vessel must be lifted vertically (see drawings on lifting options) and set down onto the base.
4. Level the pressure vessel by using a level on at least 4 points around the outer diameter of the pressure vessel.
5. Once you are satisfied that the pressure vessel is level, the pressure vessel must be allowed to set (undisturbed) for at least 8 hours.
6. Install the pressure vessel.

27

---

## BASIC HANDLING RULES



Never roll or slide a pressure vessel on its side.



Never drop a pressure vessel or allow hard impact or abrasion of the pressure vessel from contact with walls, partitions, tools, or equipment.



Hoist operators must follow proper rigging procedures.



Avoid use of hooks or equipment on the inside of the pressure vessel.



Never fasten cables or chains around pressure vessel. Use canvas or nylon straps to avoid damage to the flange area.

# STRUCTURAL

The leader in Composite Pressure Vessel Technology  
Industrial Parkway • Chardon, OH 44024 U.S.A.  
Tel: 440-286-4116 • Fax: 440-286-4351

## **Section 11 Warranty**

---

### **Commercial Unit Warranty**

All equipment manufactured by WaterGroup Companies Inc. / WaterGroup Inc. is warranted against defects in material or workmanship for the following periods

- Fiberglass tanks - 5 Years
- Brine Tank - 1 Year
- Control Valve and Electronics - 2 Years
- Brine Tank Air Check Valve - 2 Years
- All other components are for a period of one year

If a part proves defective within the warranty period, it should be returned to the factory, transportation charges prepaid, together with the serial number of the unit and the model number and a replacement part will be supplied free of charge.

This warranty is limited to the replacement of defective parts, f.o.b. our factory, and does not cover any labor charges or payment for damages.

WaterGroup Companies Inc. / WaterGroup Inc. assumes no responsibility for consequential damage, labor or expense incurred as a result of a defect or failure to meet the terms of this warranty because of circumstances beyond its control.

Further, the warranty on any components, not of WaterGroup Companies Inc. / WaterGroup Inc. manufacture, is limited to the warranty or guarantee given by the manufacturer of the component.

Use of the product for any purpose other than its intended use will void all warranties.

WaterGroup Companies INC.  
580 Park Street  
Regina, SK  
S4N 5A9

WaterGroup Companies INC.  
265 Industrial Road  
Cambridge, ON  
N3H 4R9

WaterGroup INC.  
193 Osborne Road  
Fridley, MN.  
55432

WaterGroup INC.  
9848 Glenoaks Blvd.  
Sun Valley, CA  
91352

***THIS PAGE INTENTIONALLY LEFT BLANK***