

105 Series STS Filter

Installation, Operation & Service Instructions

- ◆ Please read carefully all instructions before proceeding with the installation. Systems must be properly installed, operated and maintained. Failure to do so voids the warranty.
- ◆ On fiberglass tanks, due to slight expansion and contraction of the tanks, flexible connectors must have been properly installed between the tank openings and rigid piping. Also a vacuum breaker(s) must have been properly installed to protect the tank from vacuum under all conditions. Failure to install flex connectors and/or vacuum breaker(s), or improper installation will void tank warranty.
- ◆ The systems must be protected from freezing temperatures and avoid installing in direct sunlight.
- ◆ Do not use the system with water that is microbiologically unsafe or of unknown quality without adequate disinfection before or after the system.
- ◆ Test the water periodically to verify that the system is operating satisfactorily. A regular preventative maintenance inspection by a water professional is recommended.
- ◆ Handle all components with care. Do not drop, drag or turn components upside down.
- ◆ Check all local plumbing and electrical codes. The installation must conform to them.
- ◆ It is recommended to wait until the entire system is fully pressurized, confirmed to be operating properly, and recheck for leaks before leaving the site.

OWNERS MANUAL

This page intentionally left blank

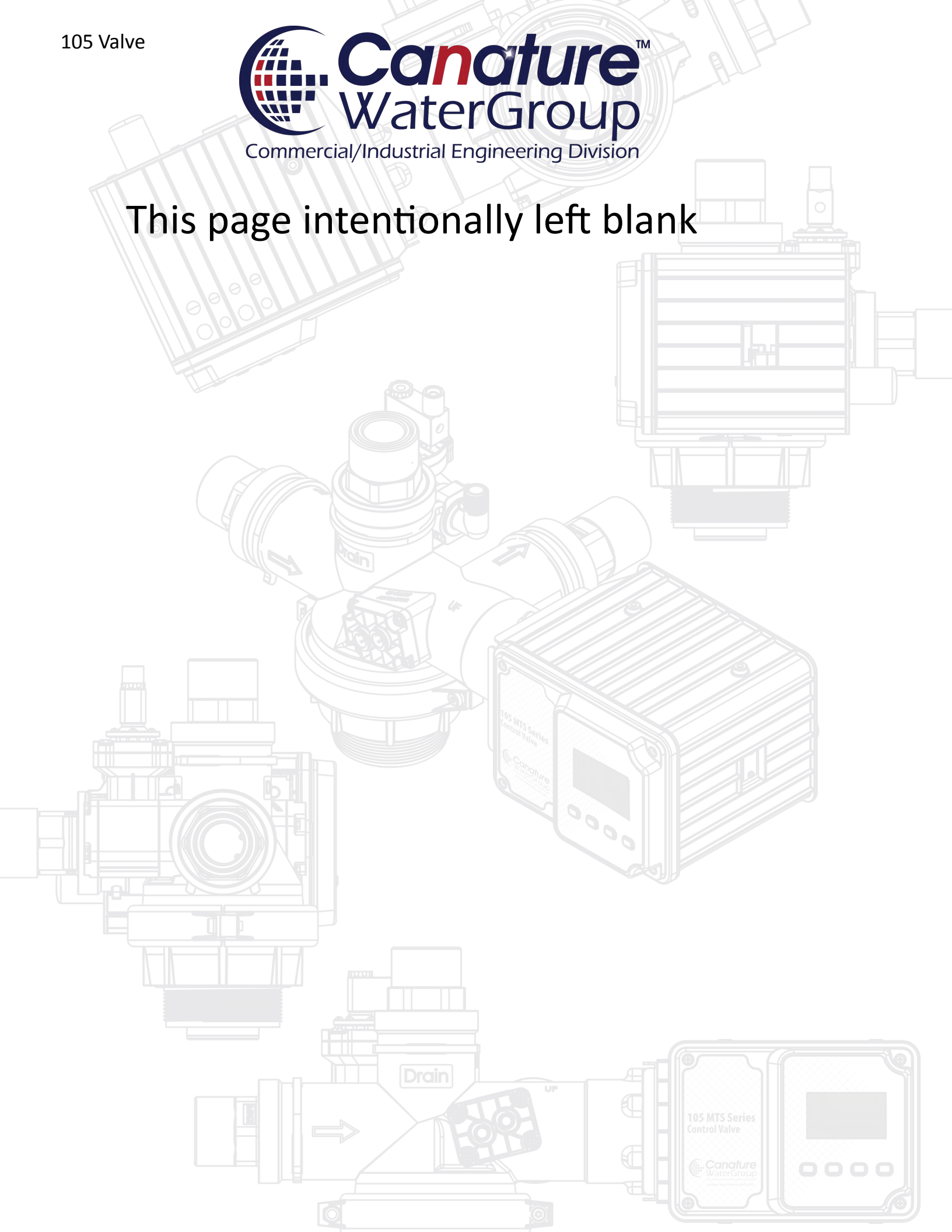

Table Of Contents

Section 1—Receiving

- 1.1 Receiving & inspection
- 1.2 Major component
- 1.3 Standard components
- 1.4 Optional components

Section 2—Specifications

- 2.0 Unit parameters
- 2.1 Model legend
- 2.2 Regeneration cycle settings
- 2.3 Installation specifications
- 2.4 General specifications
- 2.5 Valve dimensions

Section 3 - Planning location & installation

- 3.1 Location considerations
- 3.2 Materials required
- 3.3 Typical piping layout
- 3.4 Optional piping

Section 4 - Installation

- 4.0 General installation guide
- 4.1 Tank positioning
- 4.2 General piping
- 4.3 Special applications piping
- 4.4 Control valve installation

Section 5 - Media Loading

- 5.0 General guidelines
- 5.1 Media descriptions
- 5.2 Media quantities

Section 6 - Start up

- 6.0 Piping inspection
- 6.1 Startup programming guide.
- 6.2 Chemical Injection (if required)
- 6.3 Hydrocharger set-up (if required)

Section 7 - Operation

- 7.0 Operating conditions
- 7.1-7.4 Cycle operation

Section 8 - Programming Electrical

- 8.0 Key pad configuration
- 8.1 Service display screen
- 8.2 Initiating a regeneration
- 8.3 Screen display during regeneration
- 8.4 Main menu set up and programming
- 8.5 Diagnostics and history

Section 9 -General Maintenance

- 9.0 Recommended tools
- 9.1 PCB / motor / power head removal
- 9.2 Seal / spacer (lantern ring) /piston replacement
- 9.3 Clean / replace injectors, DLFC, BLFC, meter
- 9.4 Installing o-rings

Section 10 -Repair Parts

- 10.1 -Mineral tanks/ closures
- 10.2 Distribution
- 10.3.0 Valve body parts breakdown
 - 10.3.1 Brine valve injector assembly
 - 10.3.2 Piston / seals / spacers (lantern ring)
 - 10.3.4 Drain line flow control assembly DLFC
 - 10.3.5 Outlet meter assembly
 - 10.3.6 Circuit boards, cables, wiring harness
- 10.4 Media beds
- 10.5 Valve Internal Parts
- 10.6 Misc. parts

Section 11 -Troubleshooting

Section 12 -Warranty

105 MTS Series
Control Valve

Canature
WaterGroup

Receiving And Inspection

Section 1.1

Be sure to check the entire shipment for any shipping damage or lost parts. Note any damage to shipping cartons. All skids are fully shrink wrapped at the factory. Note if any skids are missing shrink wrap. If damage is present, notify the transport company immediately. The manufacturer is not responsible for damage or loss in transit.

Note: Do not discard any small parts. To avoid loss of small parts, keep them in the parts bag until you are ready to use them. Thoroughly check all boxes & cartons to ensure there are no small parts tucked inside.

Major Components

Section 1.2

Note: all external piping, drain lines, isolation valves, sample points, etc., are supplied by others.

-All filter systems will include the following:

-One electronic 105 control valve with color display. (Note any loose parts located in the valve shipping box such as adapters, couplers clips, external flow controls, etc.).

-One fiberglass media tank complete with internal hub & lateral distribution. Please note the distribution may already be installed inside the tank. If the distribution has already been installed, it must be closely inspected to ensure it was not damaged in shipping. If the distribution is cracked or broken, it must be repaired before proceeding. (For more details see section 10.1 & 10.2)

-One media bed (For more details and quantities see section 5)

-There may also be other **optional** items included such as flexible pipe connectors, vacuum release valves, etc., which are required for proper installation.

-If the filter is a manganese greensand filter, there is usually a chemical feed system also included. The basic chemical feed system consists of a chemical pump and a chemical tank. The chemical feed system may also include other optional items such as a contacting flow meter, a chemical pump controller (PCM or other) and a calibration column assembly.

-If the filter is a chemical free system, there will also be a hydro charger bank assembly (air draw assembly) and an air release valve for each tank. These items are standard for a chemical free filters and **optional** for the birm filters.

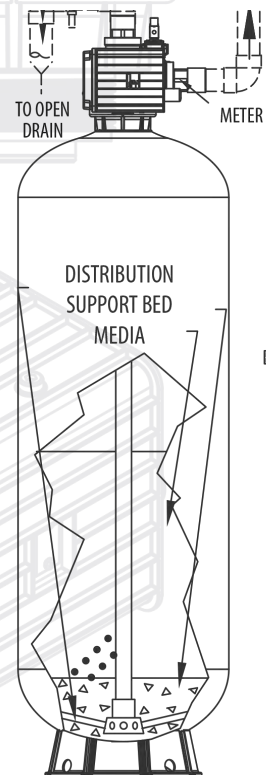

Components

Section 1.3

Below are some of the main standard components that are included with the standard unit (media bed not shown).

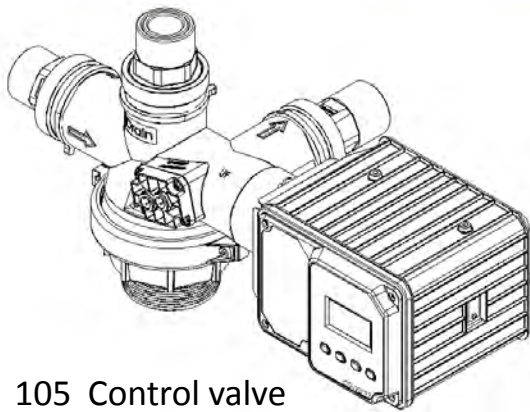

105 Control valve with internal drain line flow controls.

Media tank showing internal hub and lateral distribution. Note: due to the slight expansion and contraction of the media tank, the piping must be designed to allow some movement.

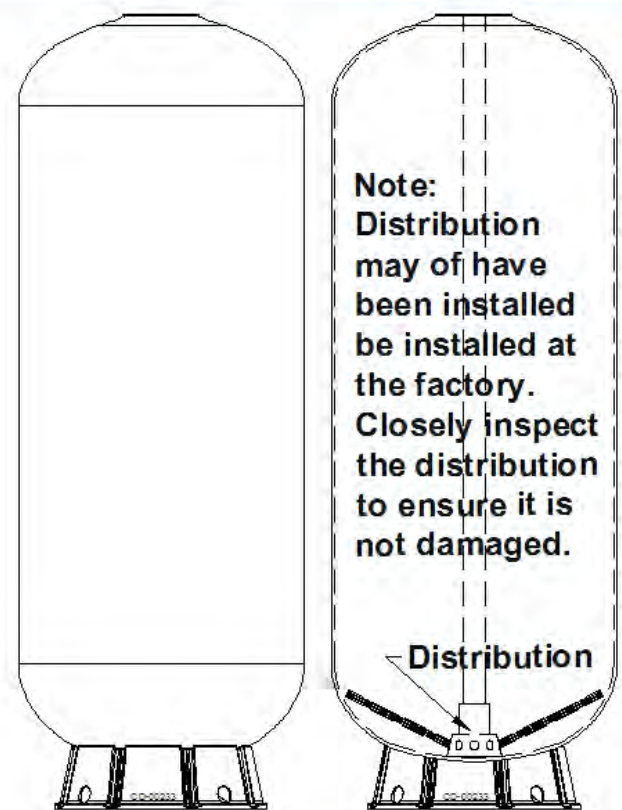

For a manganese greensand filter system, one basic chemical pump and tank are included as standard. Typical units shown below.

For a chem free filter system, one hydro-charger assembly is included. Also included is an air release valve to be installed in front of each 105 control valve. These are **optional** on birm systems.

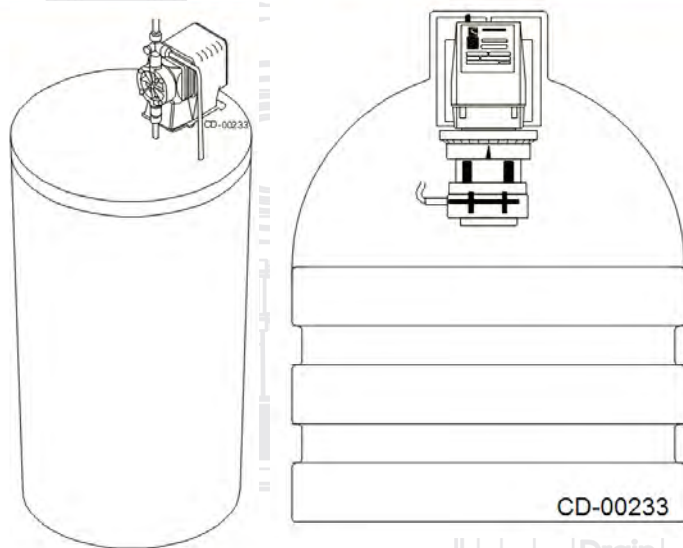

Typical chemical pumps with tanks.

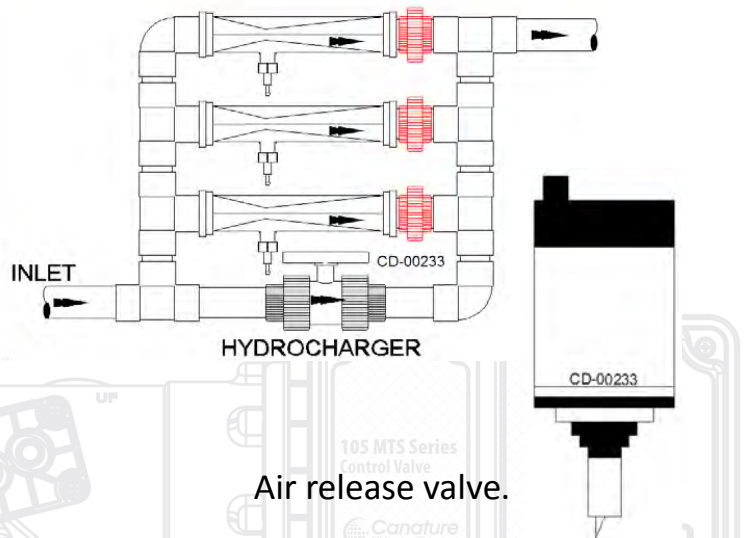

105 MTS Series Control Valve
Canature WaterGroup

Optional Components

Section 1.4

Below are some of the optional components that are available that if ordered, would be included with the system.

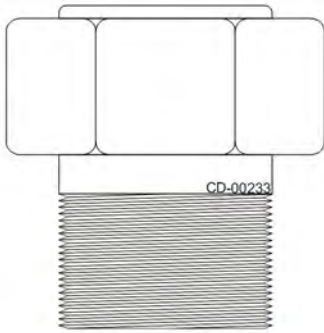

Vacuum breaker (installed on inlet line). Media tanks must be protected by from vacuum.

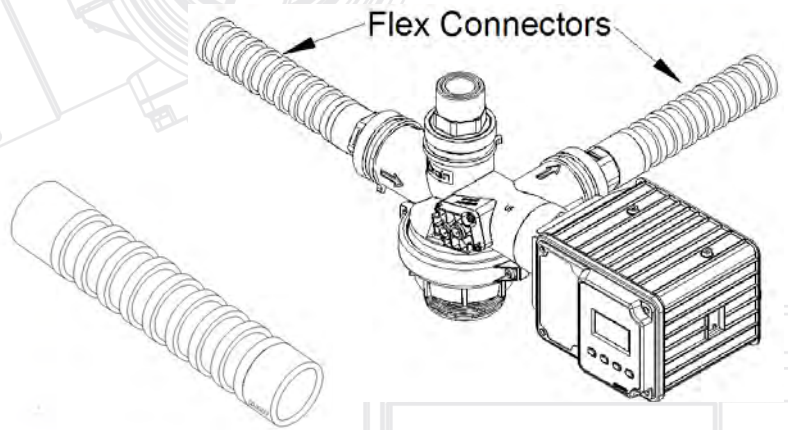

Flex connectors attach to the inlet and outlet of the control valve to allow some tank movement.

Flow paced chemical feed systems of all capacities are available. A flow paced system may also include a contacting meter, and a PCM chemical pump controller. Another option is a calibration column.

If the filter system has treated water regeneration, electric ball valves may be included.

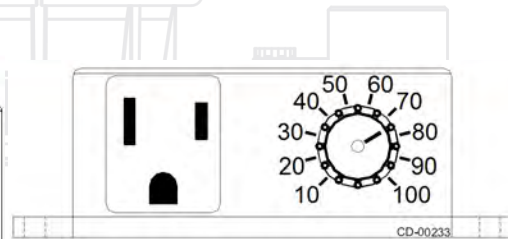
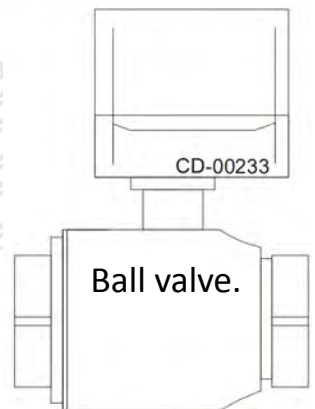
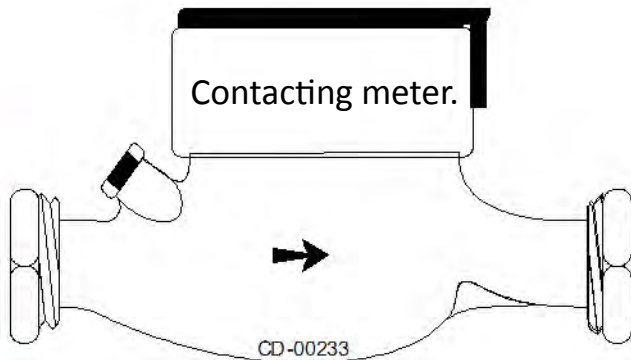

PCM chemical pump controller.

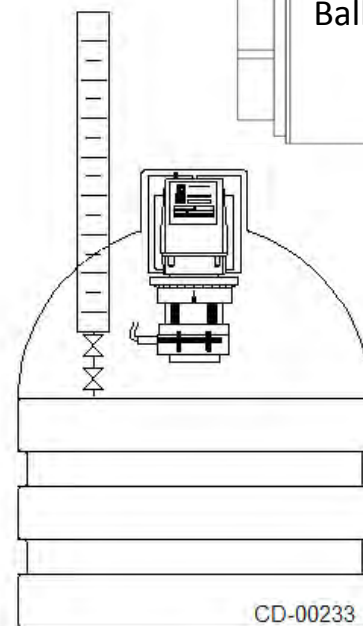

Typical chemical pump & tank with a calibration column.

Specifications

Section 2.0

Unit Parameters

- Recommended system operating pressure 30 to 100 psi (2 to 6.9 bar).
- Operating temperature 39⁰ to 100⁰ F (4⁰ to 38⁰ C).
- Electronic 105 control valve material. Plastic PPO (Noryl).
 - Maximum operating pressure 125 psi (8.6 bar).
 - 1.5" or 2" mnpt valve pipe connections.
 - Down flow or up-flow regeneration.
 - Electrical rating 120 V / 60Hz input- 24V / 60Hz output.
 - Class 2 transformer.
- Mineral tanks. Corrosion resistant fiberglass reinforced polyethylene.
 - 24" diameter and below are NSF /ANSI 44.
 - 30" diameter and above are NSF/ ANSI 61.
 - Maximum vacuum : 127 Hg.
 - Maximum operating pressure 150 psi (10.3 bar).
- Internal hub and lateral distribution.
- NSF approved media.

Model Legend

Section 2.1

105 STS AC 18-1.5" Single Carbon Filter

Model: 105STS AC 18-1.5"SC000

Valve Series	Filter Type	Filter Size Diameter	Valve Size	Number Of Tanks	System Type	Options Last 3 Digits
105STS -Single unit c/w 105 series control valve 1.5" or 2"	MM-Multimedia	14	1.5"	S - Single	C-Calender Clock 4-Single Meter Initiated	0-Standard
	AC-Activated Carbon	16	Standard up to 21"			L-Lockout contact
	MG-Manganese Greensand	18	2"			S-Side mount
		21				T-Treated water regeneration
	CF-Chemical Free	24	X-Non standard option			
	BF-Birm	30				
NX-Nextsand	36					

105 modified.xlsx

Backwash Flow Rates & Cycle Settings

Section 2.2

Backwash Flow Rates						
Tank Diameter	Multi-Media (0)	Carbon (4)	Greensand (5)	Chem Free (6)	Birm (8)	Nextsand (9) ***
14	12	10	10	10	10	12
16	16.5	15	15	15	15	16.5
18	22	20	20	20	20	22
21	30	25	25	25	25	30
24	43	30	30	30	30	43
30	60*	51	51	51	51	
36		70	70	70	70	

*** Nextsand backwash flowrates for 40F water. Warmer water requires higher backwash flowrates

Standard Cycles Backwash 12 Minutes, Fast Rinse 6 Minutes.

105 Modified.xlsx

*****Nextsand**

Typical Backwash Flow Requirement, vs Water Temp*

Flow	80°F (27°C)	70°F (21°C)	60°F (16°C)	50°F (10°C)	40°F (4°C)
U.S. gpm/ft ²	22.3	19.8	17.2	14.8	12.5
m/h	54.5	48.4	42	36.2	30.6

*40% bed expansion.

Cone shaped flow control buttons have markings on front and back of the cone. See section 10.3.4.

4#- 8 gpm: 5# - 12 gpm: 6# - 15 gpm: 7# - 20 gpm

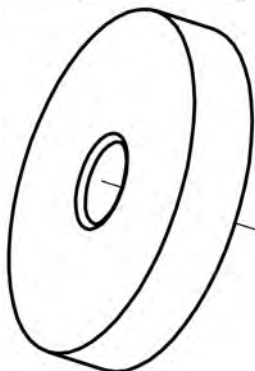

Flat flow control button go in holder. See section 10.3.4.

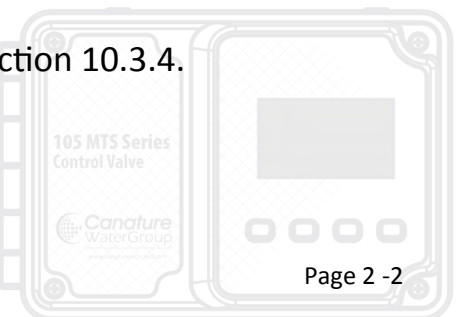

General Specifications

Section 2.3

Installation Space

Single Series Model	Mineral Tank		Installation		
	Diameter	Height	Height	Depth	Width
	in	in	in	in	in
	mm	mm	mm	mm	mm
105STS 14-1.5"	14	65	86	32	20
	356	1,651	2,184	813	508
105STS AC16-1.5"	16	65	88	33	22
	406	1,651	2,235	838	559
105STS 18-1.5"	18	65	88	34	24
	475	1,651	2,235	864	610
105STS 21-1.5"	21	62	88	36	27
	533	1,575	2,235	914	686
105STS 24-2"	24	72	96	37	30
	610	1,829	2,438	940	762
105STS AC30-2"	30	72	107	40	36
	762	1,829	2,718	1,016	914
105STS 36-2"	36	72	107	44	42
	914	1,829	2,718	1,118	1,067

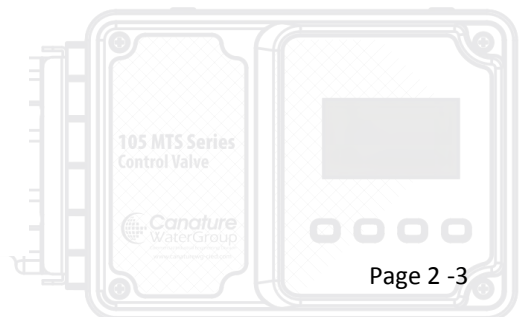
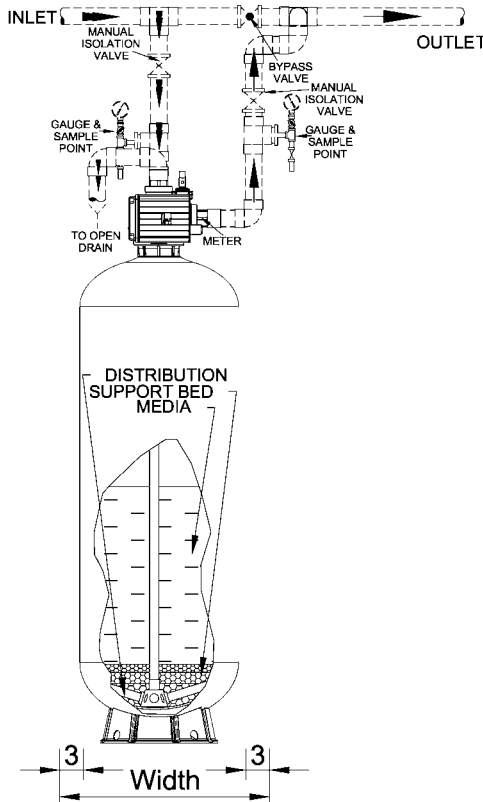

General Specifications

Section 2.4

Multi Media Filters

Single Series Model	Typical	RO	Max Flow To Drain	Pipe Size		Media	Mineral Tank		Installation			Shipping Weight	Operating Weight
	Service Flow Rate			Service	Drain	Per Tank	Diameter	Height	Height	Depth	Width		
	USGPM	USGPM	USGPM	in	in	CF	in	in	in	in	in	lbs	lbs
	l/s	l/s	l/s	mm	mm	m ³	mm	mm	mm	mm	mm	kg	kg
105STS/MTS MM14-2"*	10	8	10	2"*	2"*	2.65	14	65	86	32	20	413	813
	0.63	0.5	0.64	51	51	0.08	356	1,651	2,184	813	508	188	369
105STS/MTS MM16-2"*	14	11	15	2"*	2"*	3.5	16	65	88	33	22	513	1,013
	0.88	0.69	0.95	51	51	0.1	406	1,651	2,235	838	559	233	460
105STS/MTS MM18-2"*	17	13	15	2"*	2"*	4.4	18	65	88	34	24	651	1,251
	1.07	0.82	1.26	51	51	0.13	475	1,651	2,235	864	610	295	568
105STS/MTS MM21-2"*	24	19	25	2"*	2"*	6	21	62	88	36	27	827	1,627
	1.5	1.2	1.89	51	51	0.17	533	1,575	2,235	914	686	375	738
105STS/MTS MM24-2"	30	25	40	2"	2"	7.7	24	72	96	37	30	1,027	2,127
	1.89	1.58	2.52	51	51	0.22	610	1,829	2,438	940	762	466	965
105STS/MTS MM30-2"	48	39	60	2"	2"	12.5	30	72	107	40	36	1,800	3,400
	3.02	2.457	3.78	51	51	0.35	762	1,829	2,718	1,016	914	817	1,543

* 1.5" also available

Carbon Filters

Single Series Model	Typical	RO	Max Flow To Drain	Pipe Size		Media	Mineral Tank		Installation			Shipping Weight	Operating Weight
	Service Flow Rate			Service	Drain	Per Tank	Diameter	Height	Height	Depth	Width		
	USGPM	USGPM	USGPM	in	in	CF	in	in	in	in	in	lbs	lbs
	l/s	l/s	l/s	mm	mm	m ³	mm	mm	mm	mm	mm	kg	kg
105STS/MTS AC14-2"*	6	3	11	2"*	2"*	2.75	14	65	86	32	20	263	663
	0.38	0.19	0.69	51	51	0.08	356	1,651	2,184	813	508	119	301
105STS/MTS AC16-2"*	8	4	14	2"*	2"*	3.5	16	65	88	33	22	303	803
	0.5	0.25	0.88	51	51	0.1	406	1,651	2,235	838	559	137	364
105STS/MTS AC18-2"*	10	5	17	2"*	2"*	4.5	18	65	88	34	24	395	995
	0.63	0.32	1.07	51	51	0.13	475	1,651	2,235	864	610	179	451
105STS/MTS AC21-2"*	14	7	24	2"*	2"*	6	21	62	88	36	27	479	1,279
	0.88	0.44	1.51	51	51	0.17	533	1,575	2,235	914	686	217	580
105STS/MTS AC24-2"	19	8	30	2"	2"	8	24	72	96	37	30	573	1,673
	1.2	0.5	1.89	51	51	0.23	610	1,829	2,438	940	762	260	759
105STS/MTS AC30-2"	29	12	50	2"*	2"	12.5	30	72	107	40	36	1,200	2,800
	1.83	0.76	3.15	51	51	0.35	762	1,829	2,718	1,016	914	544	1,270
105STS/MTS AC36-2"	42	18	70	2"	2"	17.6	36	72	107	44	42	1,600	3,600
	2.65	1.13	4.41	51	51	0.50	914	1,829	2,718	1,118	1,067	726	1,633

* 1.5" also available

Control Valve

General Specifications

Section 2.4

Manganese Greensand Filters

Single Series Model	0-3 PPM	3-8 PPM	8-15 PPM	Max Flow To Drain	Pipe Size		Media Per Tank	Mineral Tank		Installation			Shipping Weight	Operating Weight
	Max Service Flow Rate				Service	Drain		Diameter	Height	Height	Depth	Width		
	USGPM	USGPM	USGPM	USGPM	in	in	CF	in	in	in	in	in	lbs	lbs
	l/s	l/s	l/s	l/s	mm	mm	m ³	mm	mm	mm	mm	mm	kg	kg
105STS/MTS MG14-2"*	5	3	2	10	2"*	2"*	2.75	14	65	86	32	20	398	798
	0.32	0.19	0.13	0.63	51	51	0.08	356	1,651	2,184	813	508	181	362
105STS/MTS S MG16-2"*	7	4	2.5	15	2"*	2"*	3.5	16	65	88	33	22	500	1,000
	0.44	0.25	0.16	0.95	51	51	0.1	406	1,651	2,235	838	559	227	454
105STS/MTS MG18-2"*	9	5	3.5	15	2"*	2"*	4.4	18	65	88	34	24	600	1,200
	0.56	0.32	0.22	0.95	51	51	0.13	475	1,651	2,235	864	610	272	544
105STS/MTS MG21-2"*	12	7	5	25	2"*	2"*	6	21	62	88	36	27	816	1,616
	0.76	0.44	0.32	1.58	51	51	0.17	533	1,575	2,235	914	686	370	733
105STS/MTS MG24-2"	16	9	6	30	2"	2"	7.85	24	72	96	37	30	1,031	2,131
	1.01	0.57	0.38	1.89	51	51	0.22	610	1,829	2,438	940	762	468	967
105STS/MTS MG30-2"	25	15	10	50	2"	2"	12.5	30	72	107	40	36	2,000	3,600
	1.575	0.945	0.63	3.15	51	51	0.35	762	1,829	2,718	1,016	914	907	1,633
105STS/MTS MG36-2"	35	21	14	70	2"	2"	17.6	36	72	107	44	42	2,600	4,600
	2.21	1.323	0.88	4.41	51	51	0.50	914	1,829	2,718	1,118	1,067	1,180	2,087

* 1.5" also available

Chem Free Filters

Single Series Model	Typical	Peak	Max Flow To Drain	Pipe Size		Media Per Tank	Mineral Tank		Installation			Shipping Weight	Operating Weight
	System Flow Rate			Service	Drain		Diameter	Height	Height	Depth	Width		
	USGPM	USGPM	USGPM	in	in	in	in	in	in	in	lbs	lbs	
	l/s	l/s	l/s	mm	mm	mm	mm	mm	mm	mm	kg	kg	
105STS	3	5	10	2"*	2"*	2.75	14	65	86	32	20	446	846
CF14-2"*	0.19	0.32	0.63	51	51	0.08	356	1,651	2,184	813	508	202	384
105STS	4	7	15	2"*	2"*	3.5	16	65	88	33	22	496	996
CF16-2"*	0.25	0.44	0.95	51	51	0.1	406	1,651	2,235	838	559	225	452
105STS	5	9	15	2"*	2"*	4.5	18	65	88	34	24	652	1,252
CF18-2"*	0.32	0.57	0.95	51	51	0.13	475	1,651	2,235	864	610	296	568
105STS	7	12	25	2"*	2"*	6	21	62	88	36	27	842	1,642
CF21-2"*	0.44	0.76	1.5	51	51	0.17	533	1,575	2,235	914	686	382	745
105STS	9	16	30	2"	2"	8	24	72	96	37	30	1,139	2,239
CF24-2"	0.57	1.01	1.89	51	51	0.23	610	1,829	2,438	940	762	517	1,016
105STS	15	25	50	2"	2"	12.5	30	72	107	40	36	2,000	3,600
CF30-2"	0.945	1.575	3.15	51	51	0.35	762	1,829	2,718	1,016	914	907	1,633
105STS	21	35	70	2"	2"	17.6	36	72	107	44	42	2,600	4,600
CF36-2"	1.323	2.21	4.41	51	51	0.50	914	1,829	2,718	1,118	1,067	1,180	2,087

* 1.5" also available

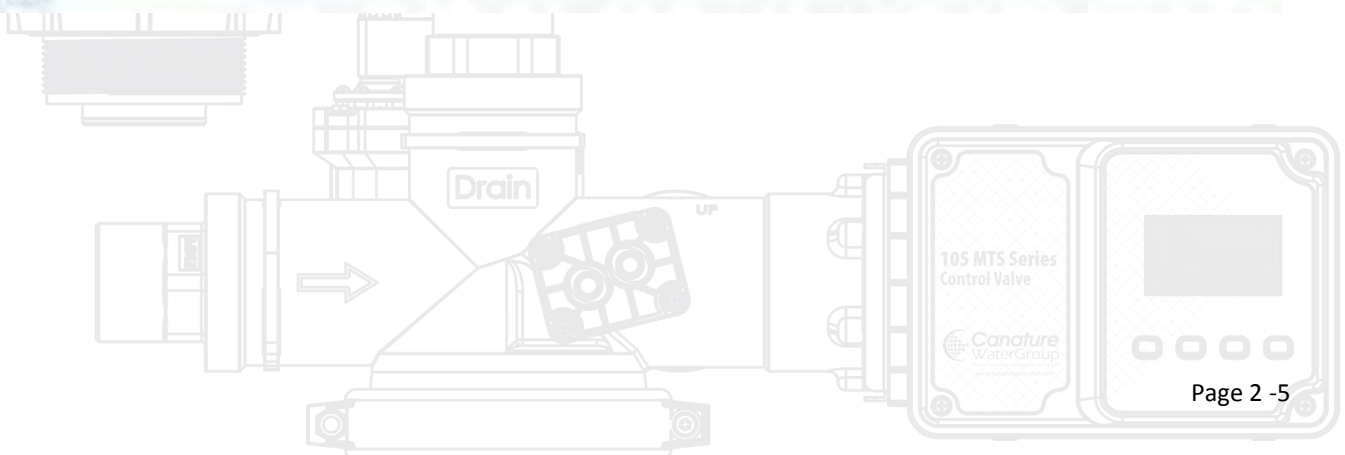

General Specifications

Section 2.4

Birm Filters

Single Series Model	Typical	Max Flow To Drain	Pipe Size		Media Per Tank	Mineral Tank		Installation			Shipping Weight	Operating Weight
	Flow Rate		Service	Drain		Diameter	Height	Height	Depth	Width		
	USGPM	in	in	in	in	in	in	in	in	in	lbs	lbs
105MTS/STS	5	10	2"*	2"*	2.5	14	65	86	32	20	307	707
BF14-2"*	0.32	0.63	51	51	0.071	356	1,651	2,184	813	508	139	321
105MTS/STS	7	15	2"*	2"*	3.5	16	65	88	33	22	366	866
BF16-2"*	0.44	0.95	51	51	0.01	406	1,651	2,235	838	559	166	393
105MTS/STS	9	15	2"*	2"*	4.5	18	65	88	34	24	466	1,066
BF18-2"*	0.57	0.95	51	51	0.13	475	1,651	2,235	864	610	211	484
105MTS/STS	12	25	2"*	2"*	6	21	62	88	36	27	587	1,387
BF21-2"*	0.76	1.58	51	51	0.17	533	1,575	2,235	914	686	266	629
105MTS/STS	16	30	2"	2"	8	24	72	96	37	30	787	1,887
BF24-2"	1.01	1.89	51	51	0.23	610	1,829	2,438	940	762	357	856
105MTS/STS	25	50	2"	2"	12.5	30	72	107	40	36	1,400	3,000
BF30-2"	1.575	3.15	51	51	0.35	762	1,829	2,718	1,016	914	635	1,361
105MTS/STS	35	70	2"	2"	17.6	36	72	107	44	42	1,900	3,900
BF36-2"	2.21	4.41	51	51	0.50	914	1,829	2,718	1,118	1,067	862	1,770

* 1.5" also available

Next Sand Filters

Single Series Model	Typical	Peak	RO	Max Flow To Drain	Pipe Size		Media Per Tank	Mineral Tank		Installation			Shipping Weight	Operating Weight
	Max. Recommended Flow Rates				Service	Drain		Diameter	Height	Height	Depth	Width		
	USGPM	USGPM	USGPM	USGPM	in	in	in	in	in	in	in	in	lbs	lbs
105STS/MTS NX14-2"*	10	15	8	12	2"*	2"*	2.75	14	65	86	32	20	343	743
	0.63	0.95	0.5	0.76	51	51	0.078	356	1,651	2,184	813	508	156	337
105STS/MTS NX16-2"*	14	20	11	15	2"*	2"*	3.5	16	65	88	33	22	429	929
	0.88	1.26	0.69	0.95	51	51	0.1	406	1,651	2,235	838	559	194	421
105STS/MTS NX18-2"*	17	26	13	20	2"*	2"*	4.5	18	65	88	34	24	544	1,144
	1.07	1.64	0.82	1.26	51	51	0.127	475	1,651	2,235	864	610	247	519
105STS/MTS NX21-2"*	24	36	19	30	2"*	2"*	6	21	62	88	36	27	677	1,477
	1.51	2.27	1.2	1.89	51	51	0.17	533	1,575	2,235	914	686	307	670
105STS/MTS NX24-2"	30	47	25	40	2"	2"	8	24	72	96	37	30	857	1,957
	1.89	2.96	1.58	2.52	51	51	0.23	610	1,829	2,438	940	762	389	888

* 1.5" also available

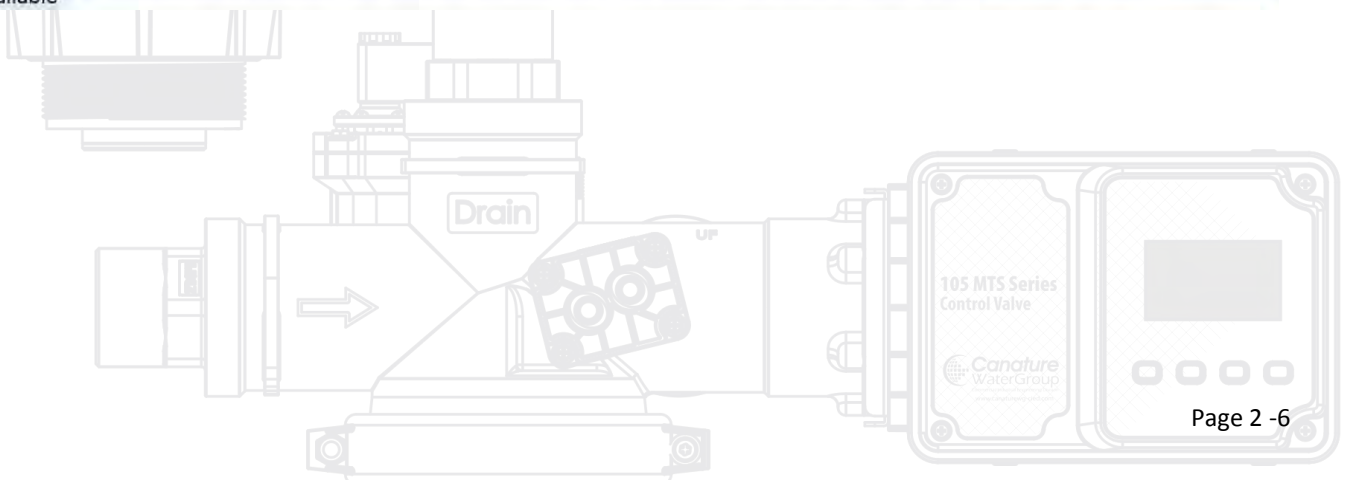

105 Valve Dimensions

Section 2.5

24.6" (625mm)

13.0"
(331mm)

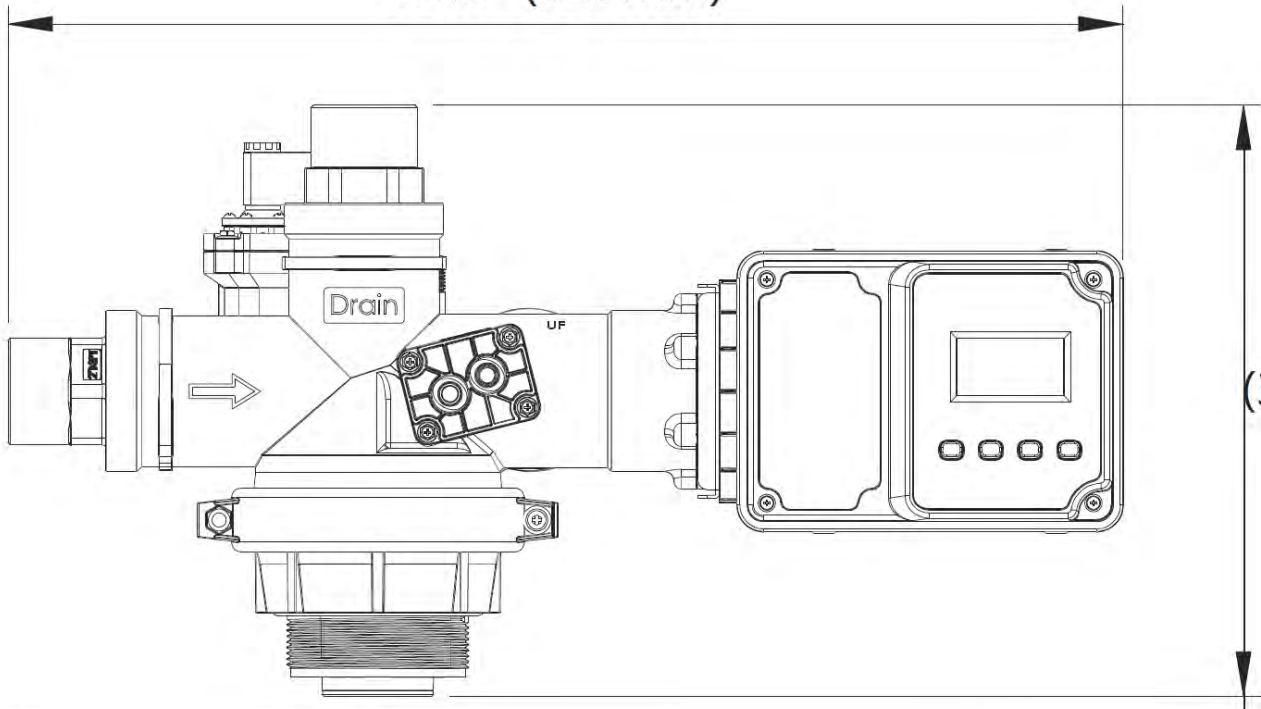

12.0" (303mm)

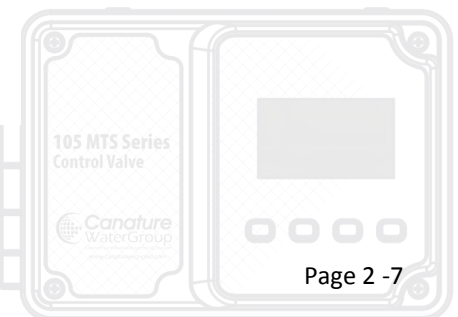
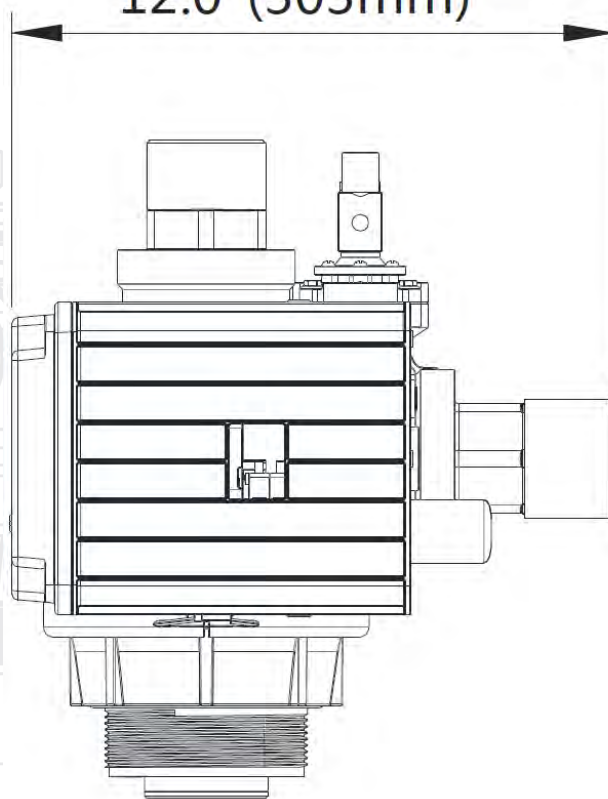

PLANS FOR LOCATION AND INSTALLATION DIAGRAMS OF SYSTEM**Section 3.1**

- **WATER SUPPLY:** The system requires a potable water supply that will provide a continuous flow to meet regeneration flow specifications. A minimum pressure of 30 psi is required at the system inlet. It is suggested that a Y type strainer be installed on the outlet of the system to prevent media getting out into the system should a distribution be compromised.
- **BOTH HOT AND COLD WATER FILTERING:** Connect the system to the water supply pipe, immediately *after* (downstream) the municipal supply water meter or well supply pressure tank. To provide *unfiltered* water to isolated faucets, if desired, run separate pipes from the water supply before the filter.
- **FILTERING HOT WATER ONLY:** Connect the system to the water supply pipe *before* (upstream) the water heater.

CAUTIONS:

- **Do not install** the filter **after**, or downstream from **the water heater**. **Hot water will damage** inner parts of the system, and may cause the loss of the media bed. This will void the system warranty.
- **To reduce the risk of hot water backing-up**, into the system, piping between the filter system and water heater should be as long as possible. A backflow preventer or check valve is also recommended between the system and the hot water heater.
- **DRAIN:** An open drain is needed nearby the filter, capable of carrying away backwash water at the rate of flow listed in the specifications. An open floor drain is preferred. Other approved open drain points are acceptable, if they do not cause a back-pressure on the system. All drain connections **MUST** have a proper air gap.
- **ELECTRICAL:** The system works on **24 AC volts only**. A direct plug-in transformer is included to reduce 120 V-60 Hz electrical power to 24 volts. An approved, grounded outlet is needed within 5' of the conditioner controller. The system includes a 5' power cable to connect between the transformer and the controller. Surge protectors are recommended.
- **SPACE REQUIREMENTS:** Be sure to allow sufficient area around the media tanks, brine tanks for refilling with salt and other service that may be required. Minimum floor space and other dimensions are shown in section 2.

Planning Location For Installation.

Section 3.2

MATERIALS YOU MAY NEED

- Use the drawings in section 3.3 as a guide for the materials required for the installation. The drawings show typical piping diagrams. All inter connecting piping, isolation & bypass valves, sample points / pressure gauges, etc. is not supplied with the system.
- If the interconnecting piping is rigid, flex connectors will be required on all connections to the media tank as some movement is required. A flex connection may also be required on the drain line as well if the piping is rigid. The standard systems do not include flex connectors but can be supplied as optional items with the system.
- A vacuum breaker is recommended on the inlet of each media tank. The standard systems do not include vacuum breakers but can be supplied as optional items with the system.
- Note: Due to slight expansion and contraction of the media tanks, the piping must be designed to allow some movement as well as protection from vacuum, flex connectors and a vacuum breakers may be required. Failure to install or improperly install them will void the warranty. See drawing below.**
- To assist in servicing the control valve, install unions or flanges on the piping connections to the control valve.
- Install unit isolation and system bypass valves. These valves allow you to turn off water to individual units in the system, for servicing. The full-line bypass will allow water to service if the system is taken offline for service.
- Inlet and outlet sample points and pressure gauges are required to confirm proper operation of the system.
- The drain line **minimum size pipe should be at least the same size as the control valve drain connection.** The drain connection at the valve is 1.5" on most filters up to and including 21" diameter mineral tanks. The drain connection is 2 on larger filters.

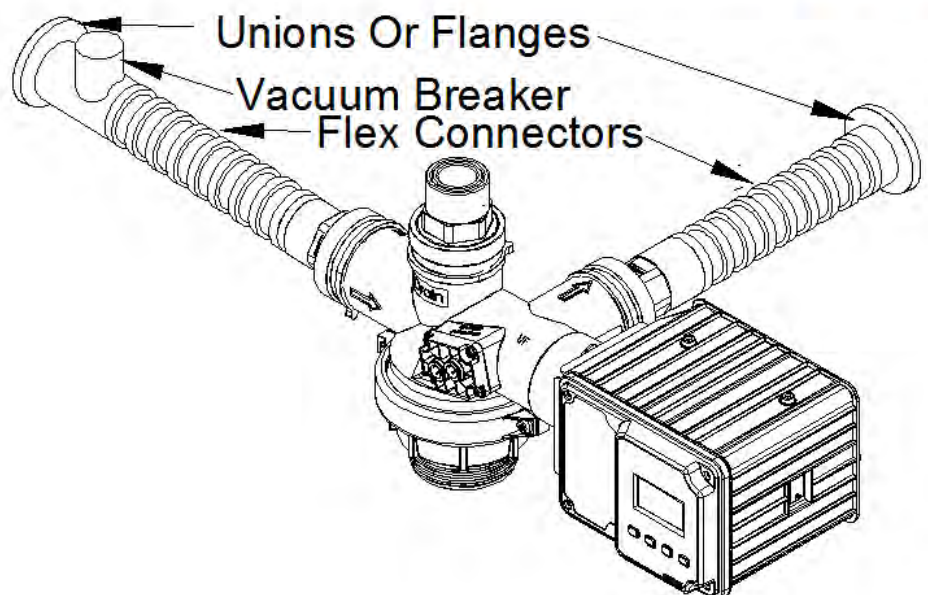

Typical Filter Piping Layout.

Section 3.3

- All filter systems are no raw water bypass during regeneration with the exception of the single filter.
- The standard single filter is raw water bypass during regeneration with no raw water bypass available as an option.
- All standard filter systems use raw water for regeneration.
- The diagram shown shows the typical piping for a filter unit. Please note that the location for flex connectors (if required) is marked with a “#” and the vacuum breaker marked with a “*”.

Note: The greensand filters and chemical free filters have a few additional items that are not included on other filter systems.

- All greensand filter systems require a chemical feed system before the filter units.
- All chemical free filter systems (and it is optional for birm filter systems) will have a hydrocharger air draw system before the filter units. In addition, on the inlet, just before each control valve, an air release valve must be installed. See diagrams on following pages.

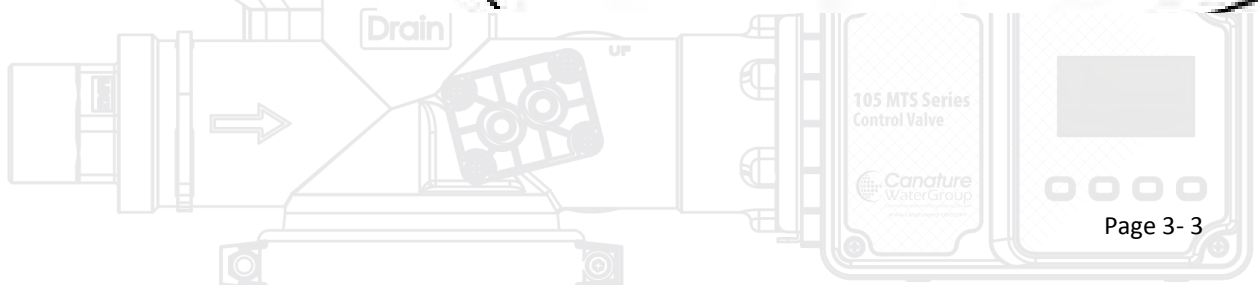
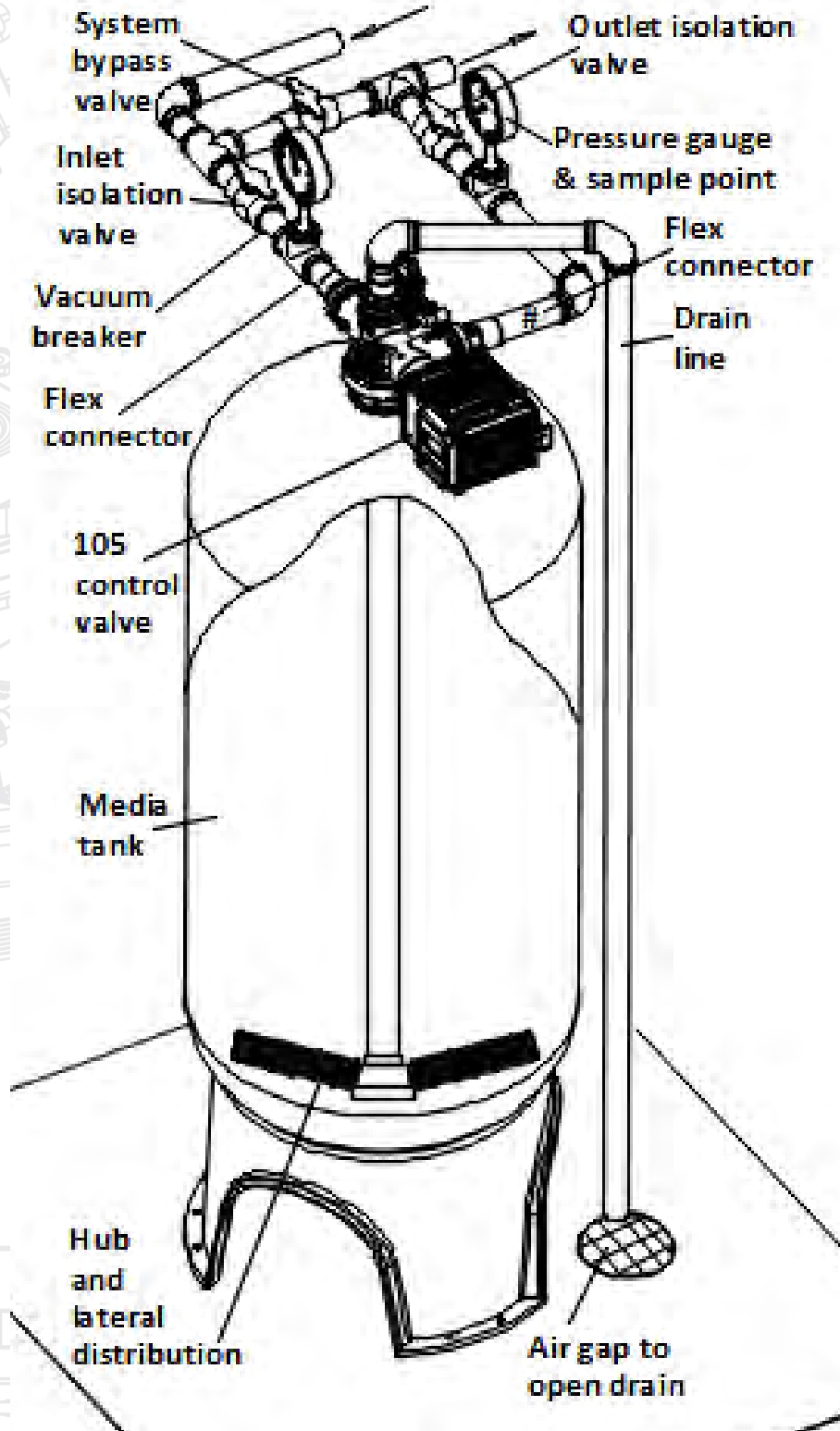

Typical Filter Piping Layout.

Section 3.3

Manganese Greensand Filters

-All commercial greensand filter systems, whether the system is a single tank, or a multiple tank system, is supplied with one chemical feed system which is to be installed upstream (before) the filter units. The standard chemical feed system is a chemical pump with a tank. There are several options available with the chemical feed systems some of which are a contacting meter (to flow pace the chemical pump), calibration column (to help determine chemical injection rate), static mixers and contact tanks.

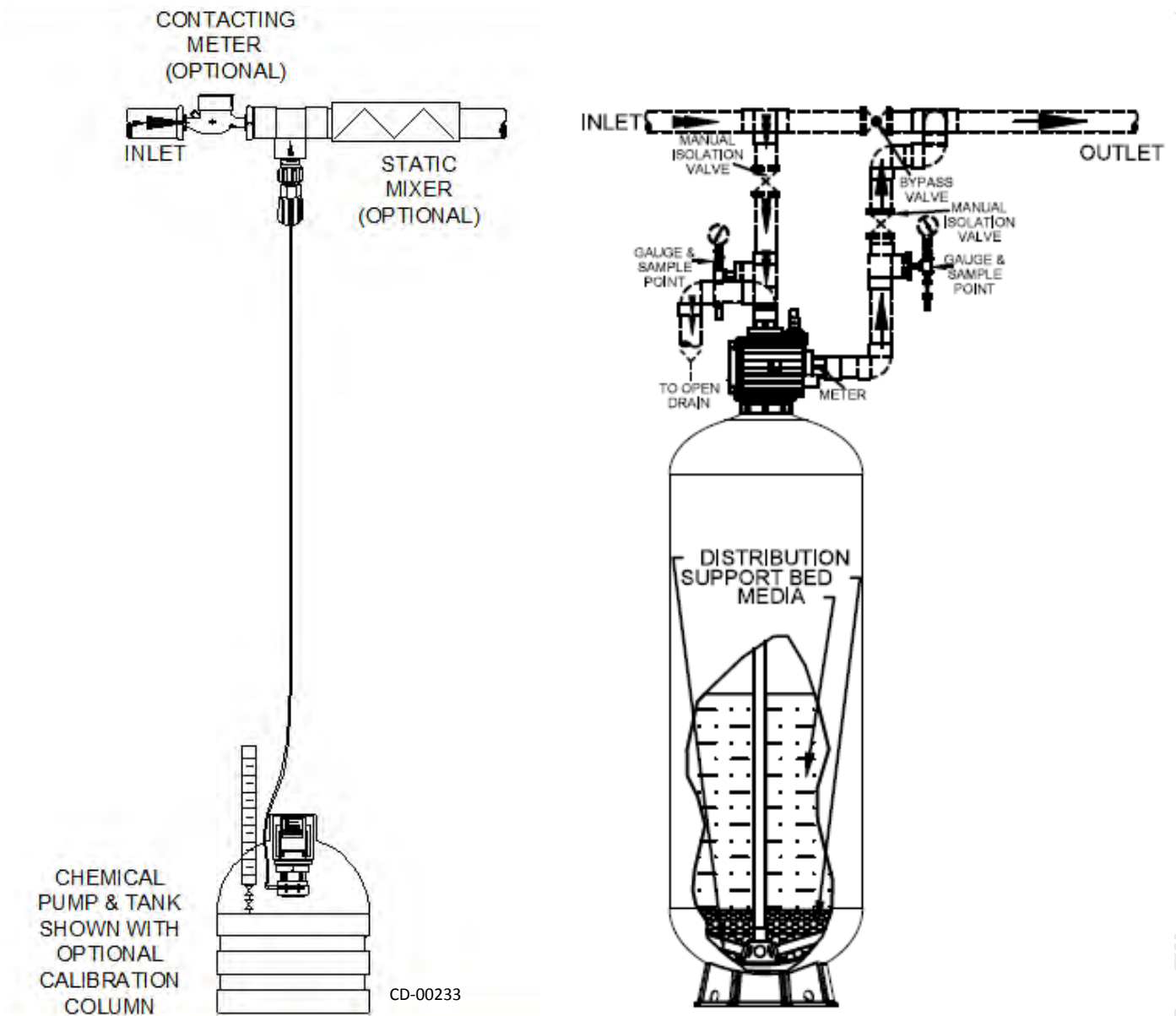

Typical Filter Piping Layout.

Section 3.3

Chemical Free Filters

All commercial greensand filter systems, whether the system is a single tank, or a multiple tank system, is supplied with one will have a hydrocharger air draw system before the filter units. *This is optional for birm filter systems.* In addition, on the inlet, just before each control valve, an air release valve must be installed. A riser pipe of at least 8" high will greatly assist in venting excess air out.

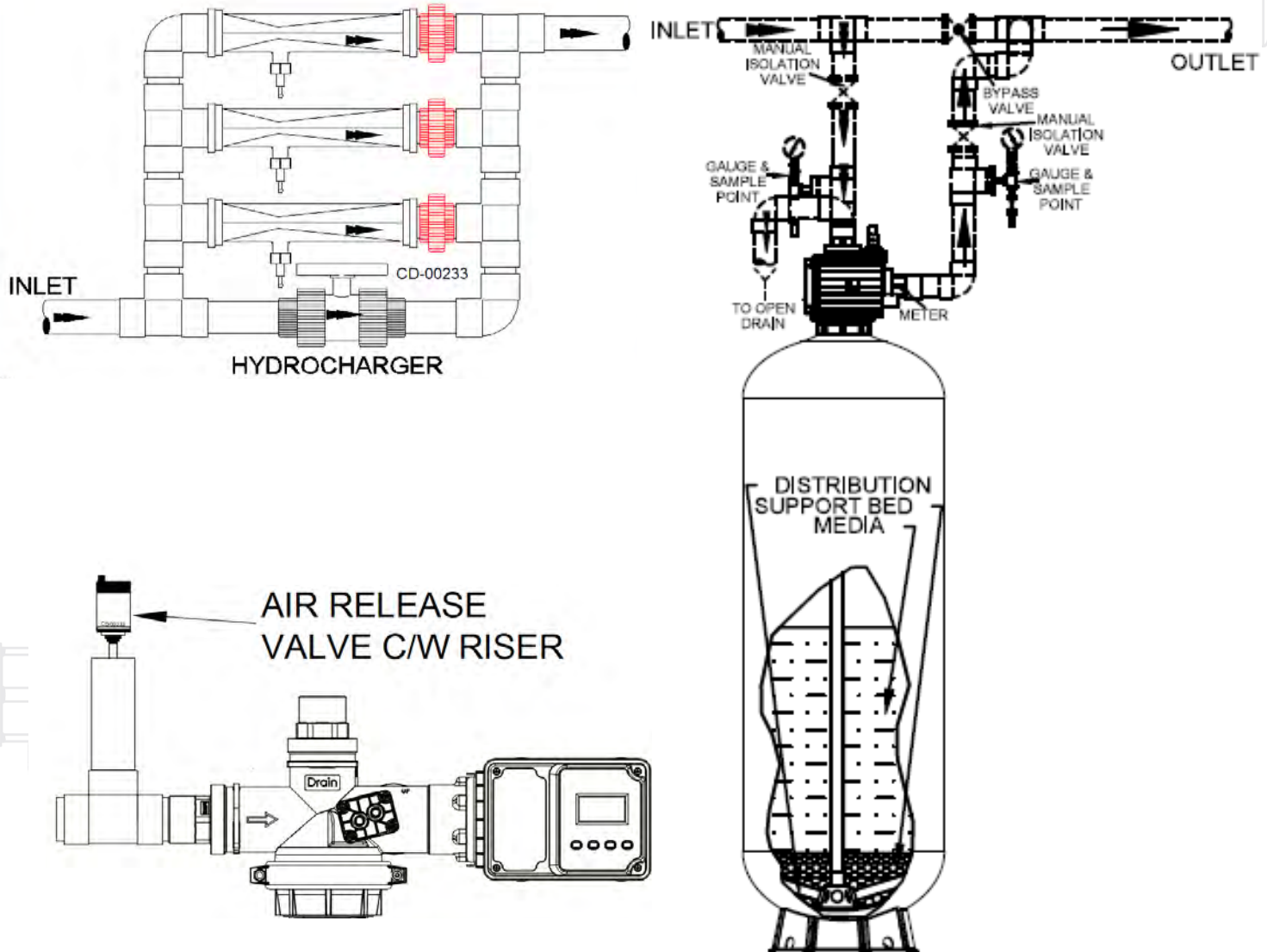

It is important to note that with the chemical free filters (and the birm filters with the air draw system), that the system must be designed **to draw air continuously**. This normally means the system is running at the full flow rate, or off.

Typical Duplex Filter Piping Layout. Raw Water Regeneration.

Section 3.3

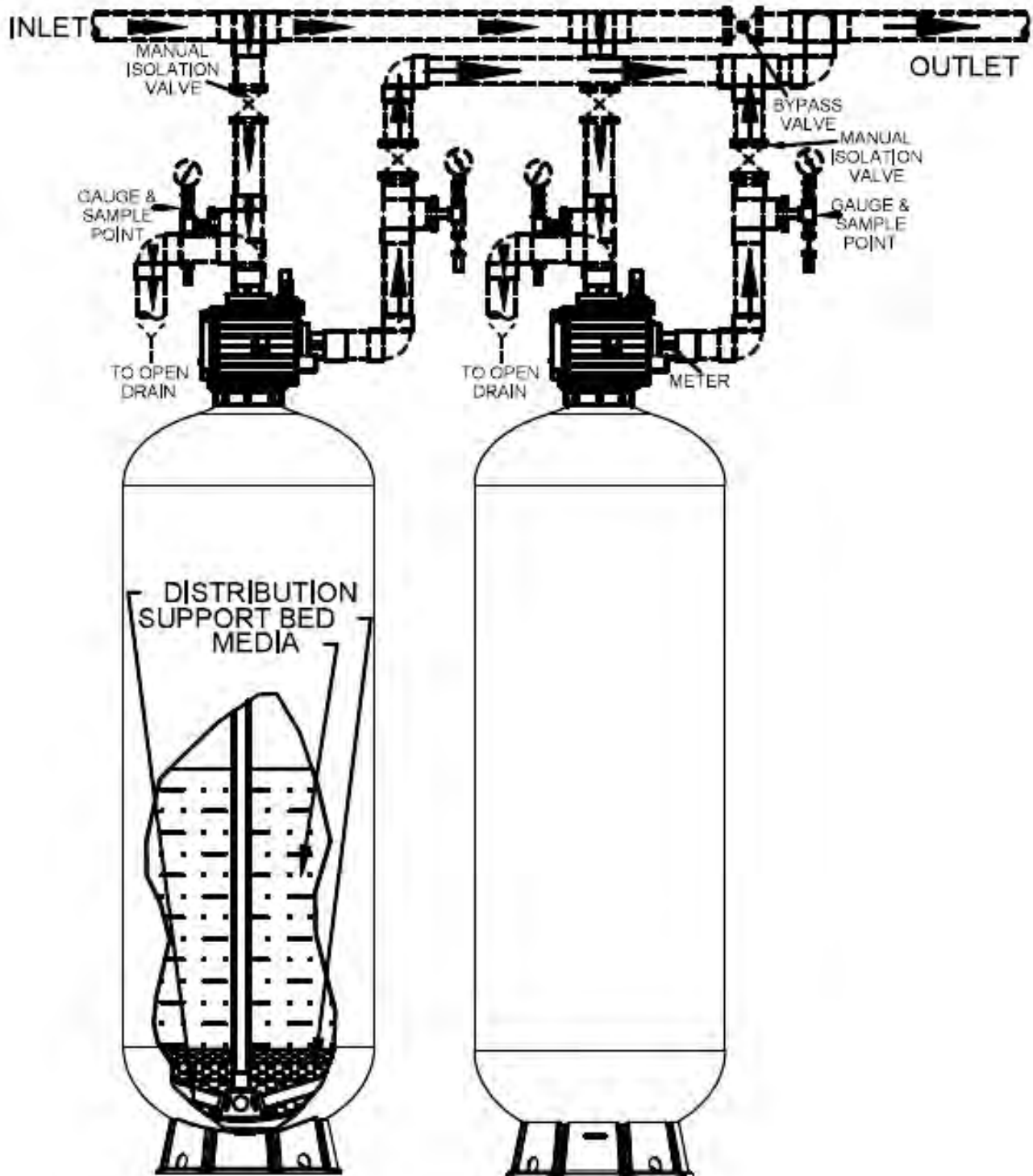

Note: Standard STS single filters are raw water bypass during regeneration and use raw water for regeneration. If duplexing, adding a no raw water bypass piston is recommended.

105 MTS Series
Control Valve

Canature
WaterGroup

Typical Filter Piping . Optional Separate Source Treated Water Regeneration Section 3.4

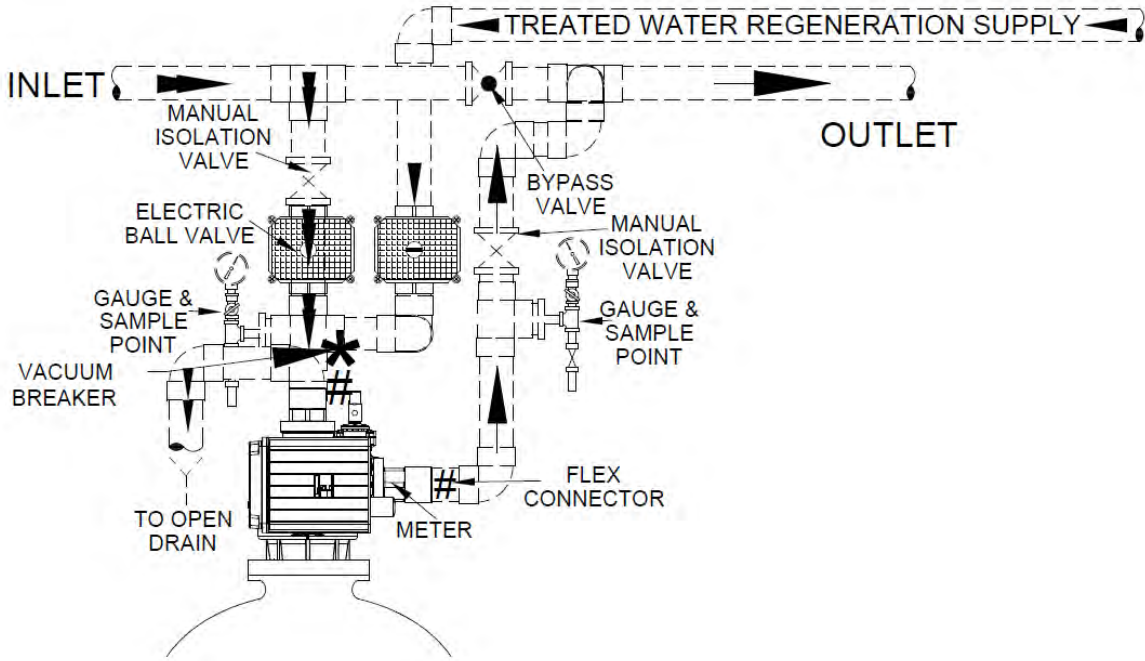

Single tank system with STS OPTIONAL no raw water bypass piston.

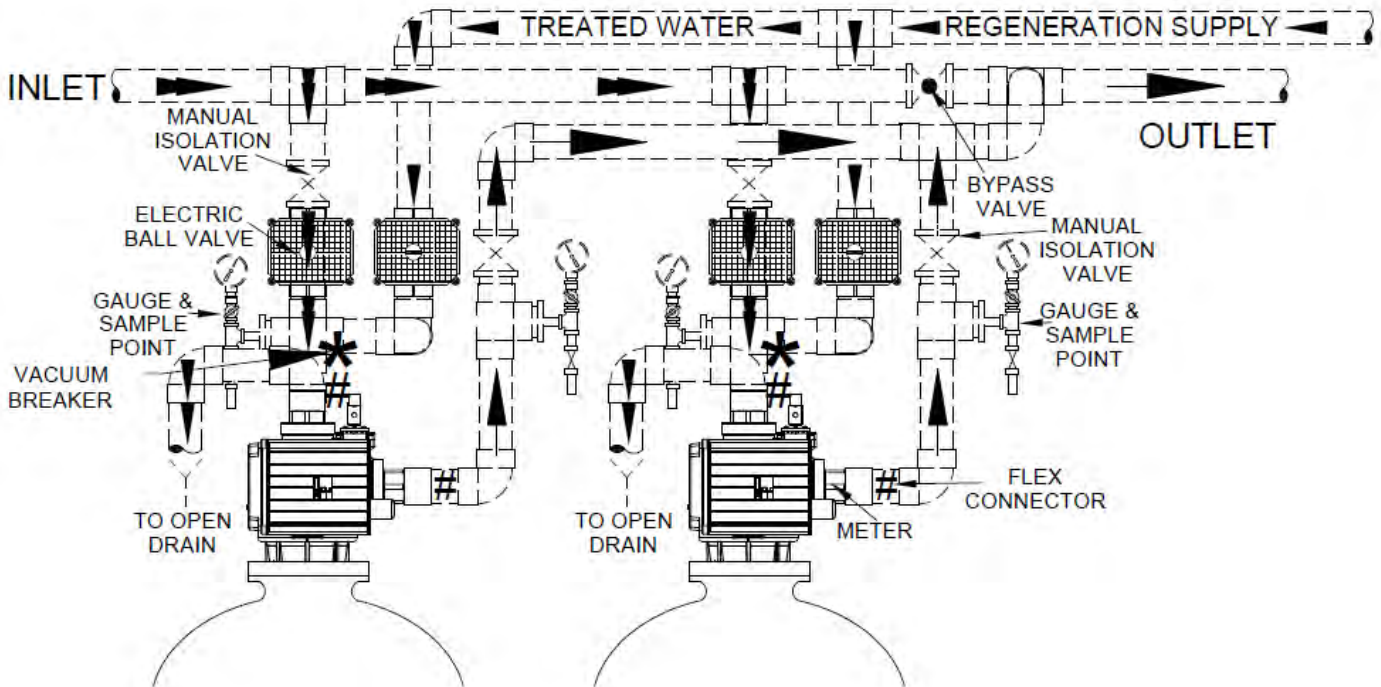

Multi tank system with STS OPTIONAL no raw water bypass pistons.

105 MTS Series Control Valve

Canature WaterGroup

General installation Guide

Section 4.0

- Section 2 outlines the space required. Section 3.1 outlines the location parameters that must be considered before starting the installation. General installation diagrams are also located in section 3.

Tank Positioning

Section 4.1

- Select the site for the installation (See section 3). The tanks should be located on a level support pad with adequate space on all sides. The system must be close to a drain that is capable of handling the maximum regeneration flow rate. Units should be within 3 feet of one another for the communication cables.
- Position the tanks as shown on the system drawings (see section 3). Check the tank orientation to ensure the piping will properly line up. If the tanks have tripod bases or separate legs, they must be securely fastened to the floor when tank locations have been finalized. Six 3/8" lag bolts with washers (2 per leg) are recommended.
- Check the internal hub and laterals distribution system for any damage that may have occurred in shipping. This inspection is critical because if the distribution is broken, the media will be flushed into the service lines. Also note that the riser tube on the 105 valve is cut 1/2" below the top of the tank (see section 5).
- Load the media into the tanks. **See section 5** for the media loading procedure.

Piping

Section 4.2

- Due to slight expansion and contraction of the tank, piping must allow some movement. **If rigid piping is used, flex connectors must be used between the hard piping and to unit connections as well as any other connections to the tank. An adequate vacuum breaker must also be used to protect the tank any vacuum condition that could occur. Failure to install or improperly install flex connectors and vacuum breakers where required may void the warranty.**
- Install the piping conforming to state, federal, provincial and local codes. All government codes and regulations governing the installation of these devices must be observed.
- Flanges or unions must be installed close to the control valves. This will allow piping to be removed for any servicing of any of the system components. Each unit requires an inlet and outlet isolation valves are required as well as a full system bypass valve.
- Sample points and pressure gauges are required on the inlet & outlet of each unit. An air release (if required) should be installed at the highest point on each unit (by others).

- All piping must be properly supported and braced to keep the weight off of the valve.
- On multiple tank systems, (normally these are MTS systems with a central controller) to promote equal water flow through each unit, the overall pipe length to each unit should be as identical as possible. Use the same pipe lengths and fittings on connections to each unit. See below. All installation diagrams for single, duplex, etc. are in section 3.

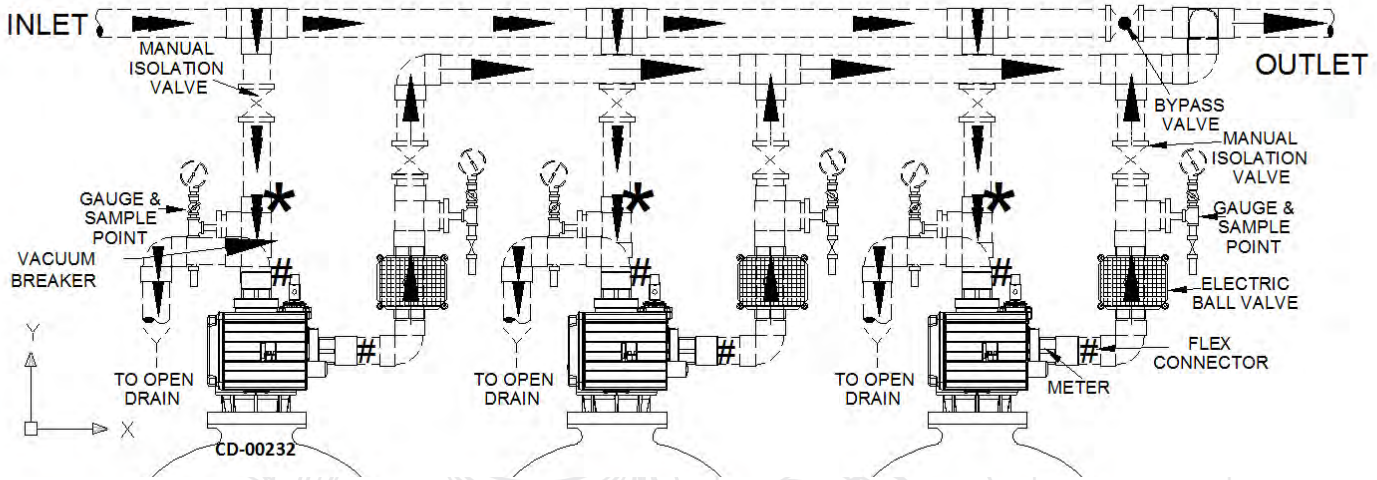

- The drain lines should be as short as possible and must piped to an open drain. Access to the drain and air gap are necessary for visual inspection and testing of the drain water. The air gap also prevents sewage backing up into the unit.
- If the drain travels a long distance or through a substantial elevation change down, an additional vacuum breaker is required on the drain line to prevent a vacuum on the mineral tank.
- The drain line size must be sized to easily handle the maximum regeneration flow rate with minimal pressure drop (2-4 psi). The floor drain must also be sized to handle the maximum regeneration flowrate. The 105 valve has a 1.5" or 2" MNPT connection. See section 2 for specifications.

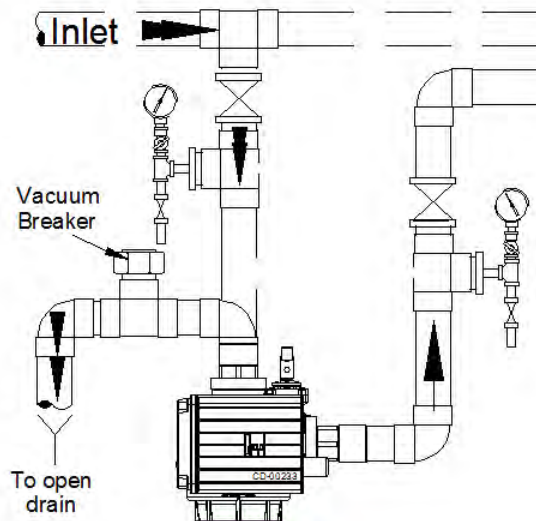

Special Piping Applications

Section 4.3

- If the treated water is flowing into an open reservoir then it is recommended that a loop with a vacuum breaker to be installed on the outlet line. This would eliminate the chance of causing a vacuum condition on the tanks when water is flowing into the reservoir as well as preventing the water in the units from siphoning down when not in operation. If the units did drain down, it could lead to operational issues for the system.

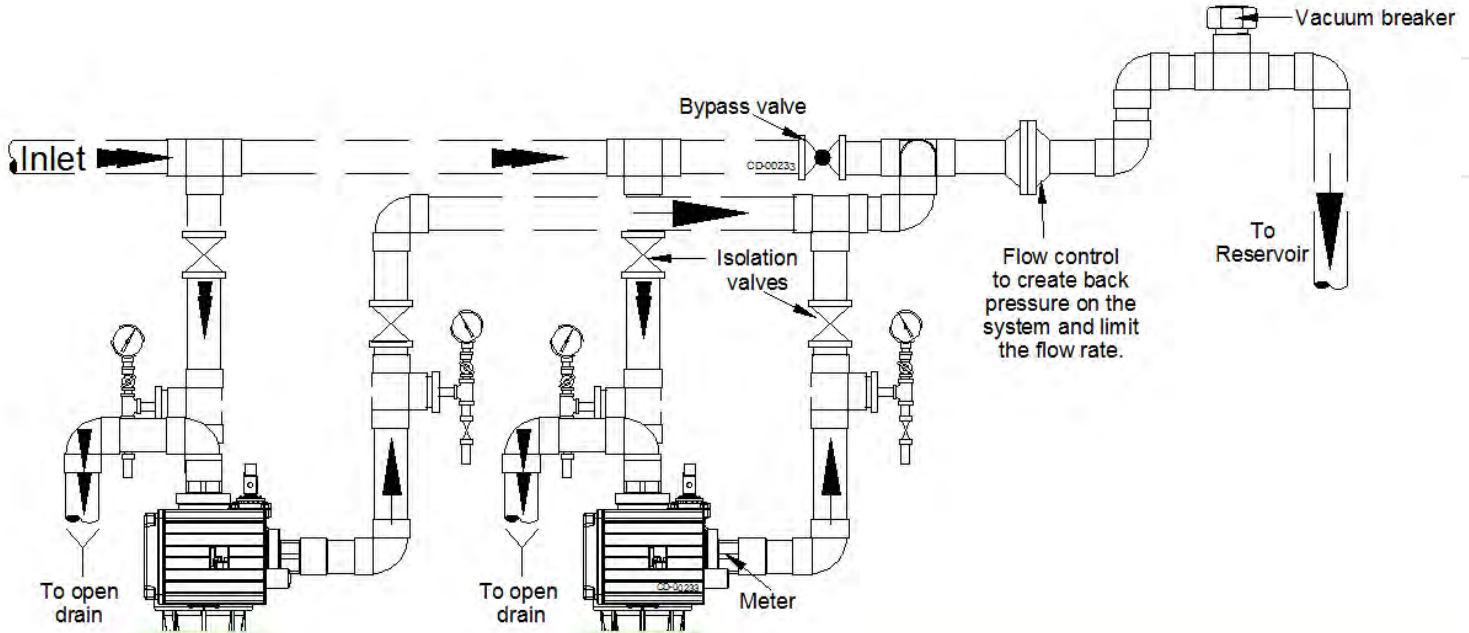

- If the system requires treated water regeneration, additional room will have to be left open for additional valves. Usually if it is a softener system, a three ball electric ball valves are required. If it is a filter system, normally only two electric ball valves are required.

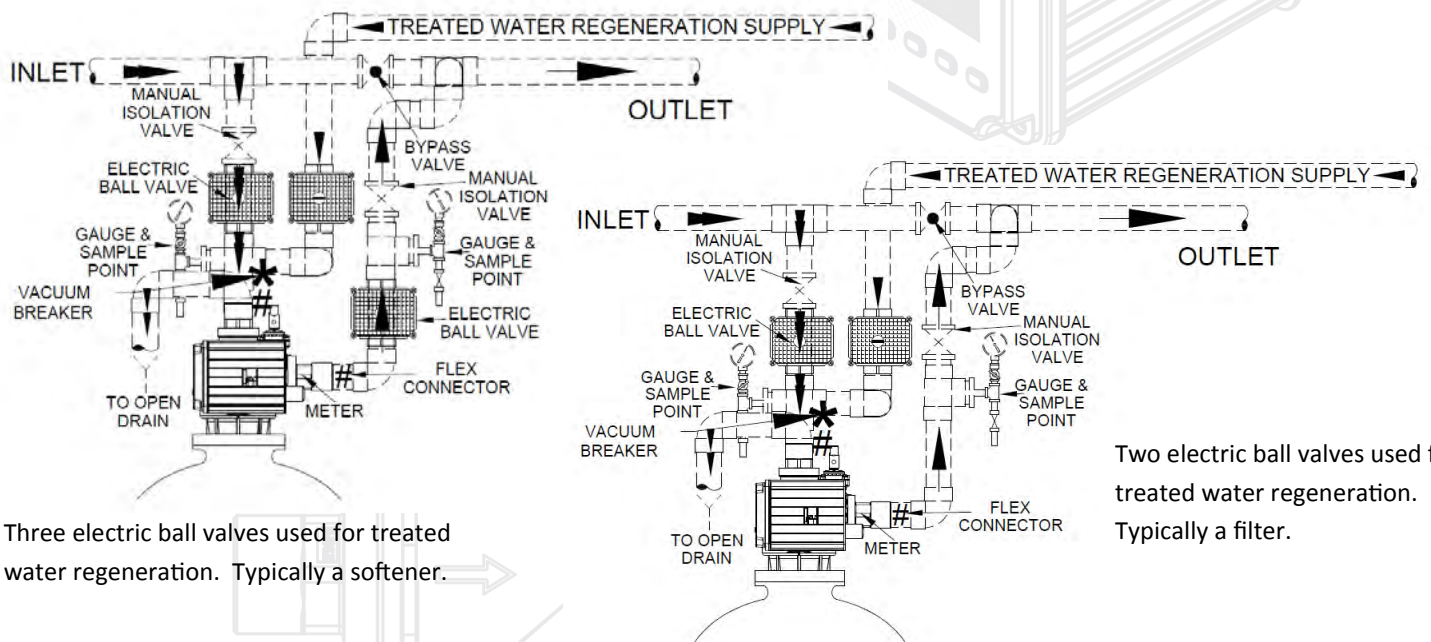

Three electric ball valves used for treated water regeneration. Typically a softener.

Two electric ball valves used for treated water regeneration. Typically a filter.

105 Control Valve

Section 4.4

- When ordered as a system, the control valve is already set up for the system with the proper backwash flow controls, etc.
- The valve piping connections are shown below. See section 2 for standard connection sizes for individual units.

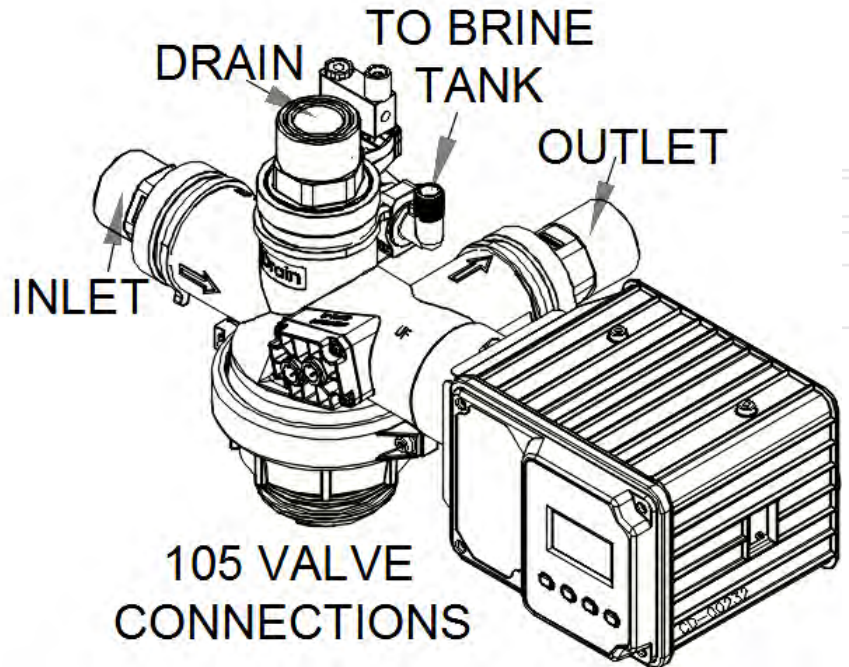

- Inlet connection 1.5" or 2" MNPT
- Outlet connection is 1.5" or 2" MNPT and has the meter mounted internally. For more information see section 10. **Confirm meter cable is properly inserted into the meter pipe adapter.**
- Drain connection is 1.5" or 2" MNPT and for most units, has the backwash flow controller mounted internally.

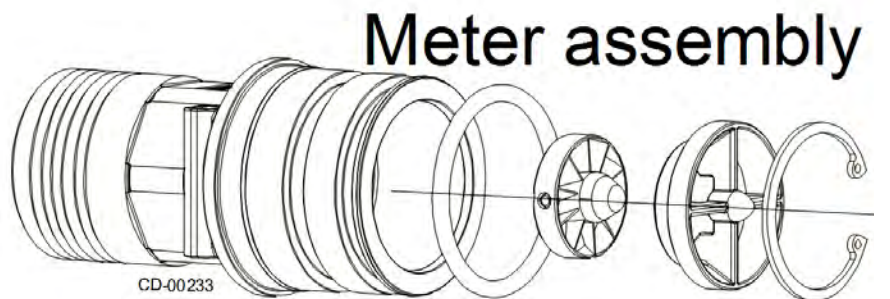

DLFC flow control assembly

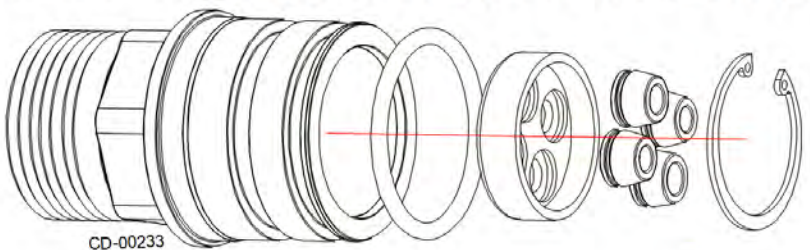

- Brine line connection (also used on a few specialized filters) is 3/4" thread. When required, the valve is supplied with an adapter to connect to 3/8" or 1/2" tubing. NOTE: for units larger than 450,000 grains, the brine line piping is 3/4" or 1" pvc and is not supplied.

Installing The Control Valve

Section 4.4

- Before mounting the control valve on top of the tank, it is recommended to fill the tanks with water. This will give the media time to soak .
- Ensure the riser tube is 1/2" below the top of the tank.

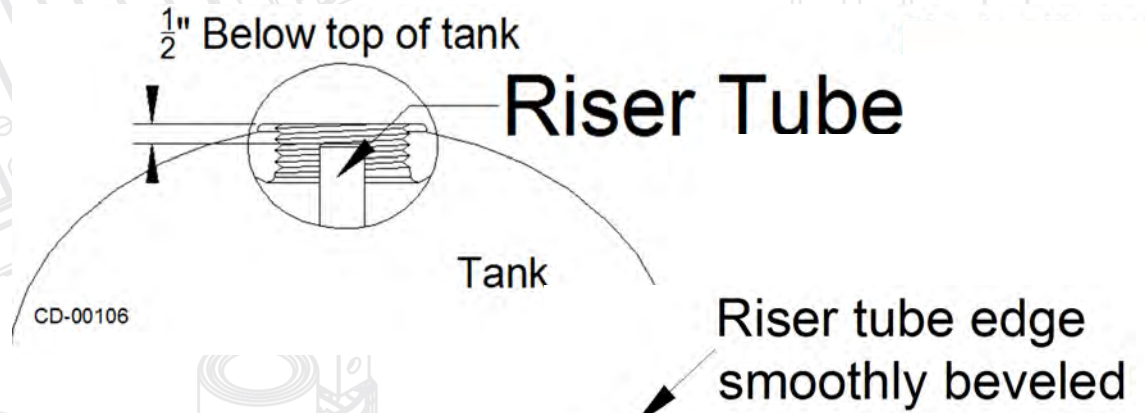

-The riser tube top end must also be properly chamfered to prevent damage to the riser tube o-ring while sliding the control valve on.

- Confirm both the riser tube o-ring and tank to valve o-ring are in place and well lubricated using silicone grease.

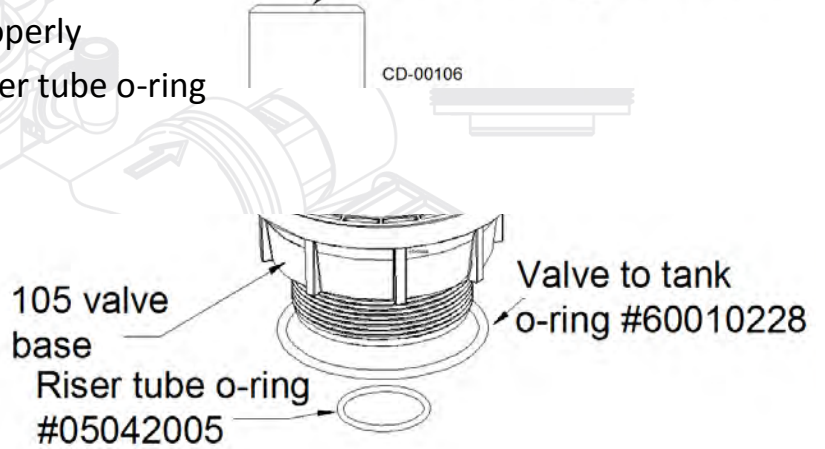

-The top portion of the 105 valve swivels on the bottom tank adapter base. Use a strap or chain wrench on the bottom tank base only when tightening the valve on to the tank.

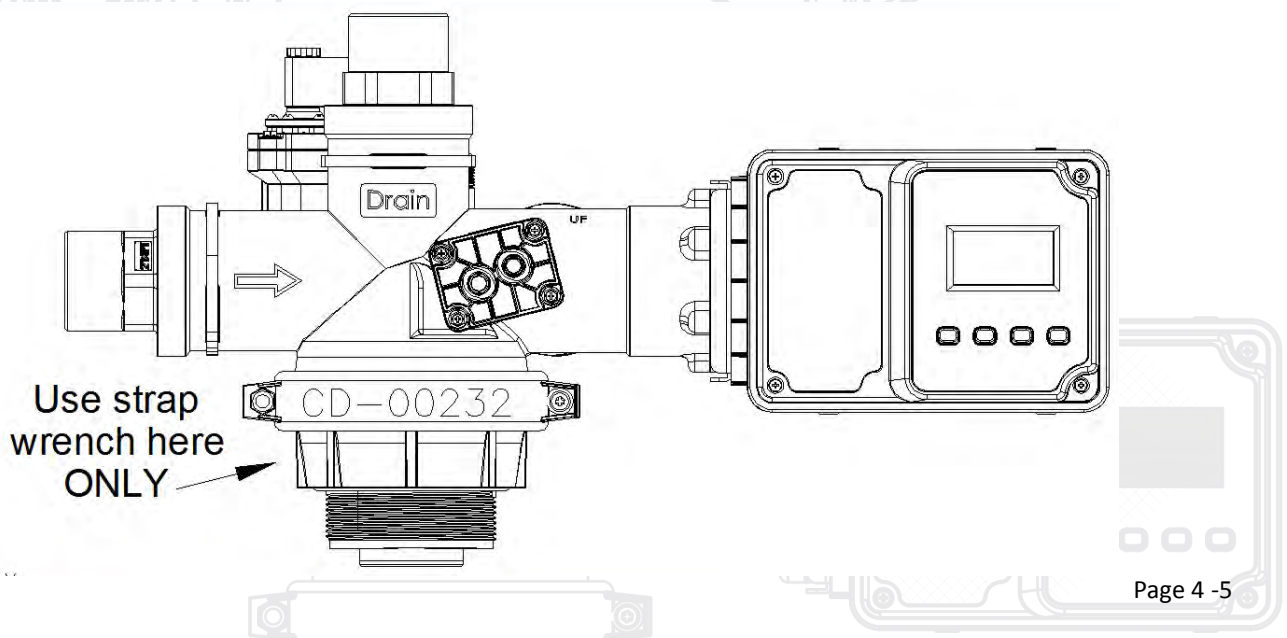

Installing The Control Valve

Section 4.4

- Confirm both the riser tube o-ring and tank to valve o-ring are in place and well lubricated using silicone grease. Ensure the riser tube is 1/2" below the top of the tank. The riser tube top end must also be properly chamfered to prevent damage to the riser tube o-ring while sliding the control valve on.

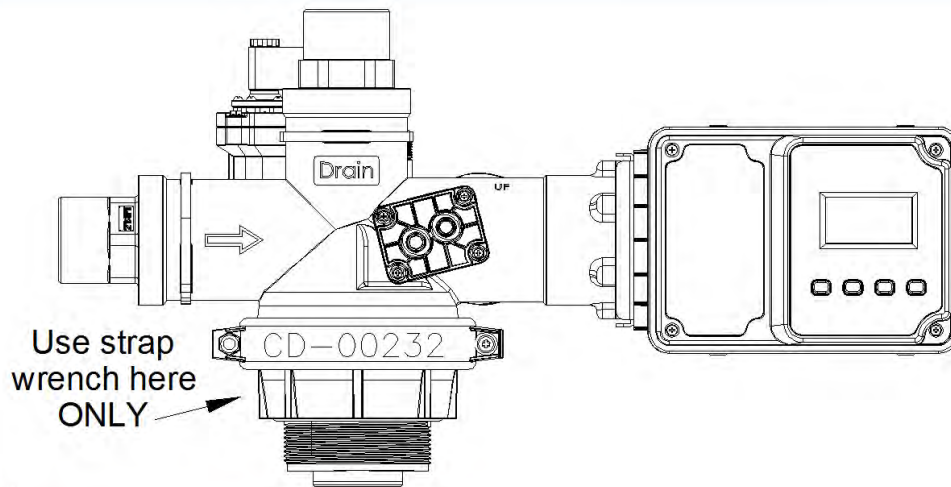

-Note: Due to slight expansion and contraction of the media tanks, the piping must be designed to allow some movement as well as protection from vacuum, flex connectors and a vacuum breakers may be required. Failure to install or improperly install them will void the warranty. See drawing.

- If the interconnecting piping is rigid, such as when the piping is in copper, flex connectors must be installed on all connections to control valve. A flex connection may also be required on the drain line as well if the piping is rigid. The standard systems do not include flex connectors but can be supplied as optional items with the system.

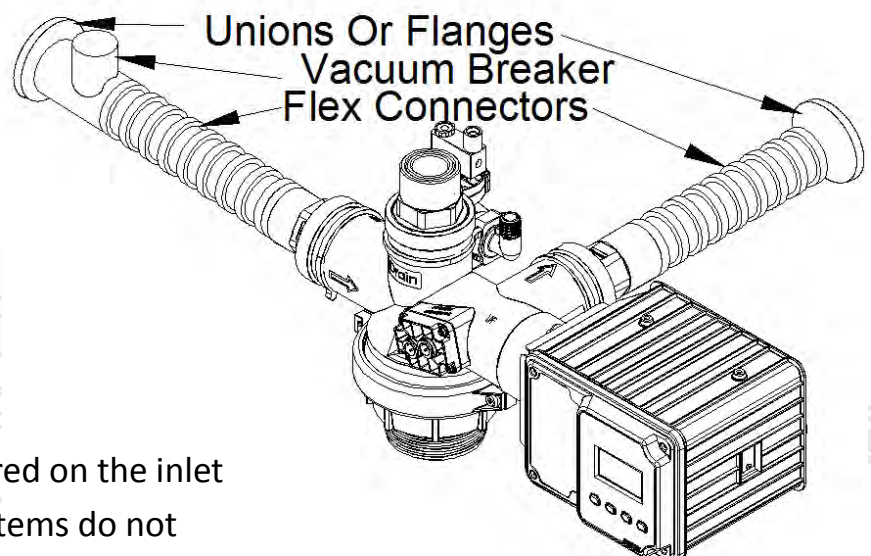

- A vacuum breaker is normally required on the inlet of each media tank. The standard systems do not include vacuum breakers but can be supplied as optional items with the system.

Media Loading

Section 5.0

– Before you start to load the media, check all of the following:

****NOTE: FOR ANY UNITS WITH TOP MOUNTED CONTROL VALVES, IT IS CRITICAL TO BE SURE THE DISTRIBUTION REMAINS CENTERED IN THE TANK AND STAYS ON THE BOTTOM OF THE TANK WHILE FILLING THE TANK WITH MEDIA. *If the distribution is not properly held down & centered, the media may have to be removed and redone.* ****

- Check the media list and confirm you have all the media required (see following tables). A large neck funnel will make the media loading easier. **Optional #99004**



- Before the media is loaded, the bottom distribution must be closely inspected to ensure it was not damaged in shipping. If the distribution is cracked or broken, it must be repaired before proceeding.

- If there are any riser pipes or any open distribution connections inside of the tank, ensure these connections are properly plugged so no media can enter them.

- Ensure the riser tube has been cut to the proper length and the riser end has been smoothly beveled. **NOTE: Depending upon the control valve used, the riser tube will have to be cut to different lengths.** On 95 series & 105 series control valves, the riser tube is cut 1/2" below the top of the tank. With most other control valves, the riser tube is cut flush with the top of the tank.

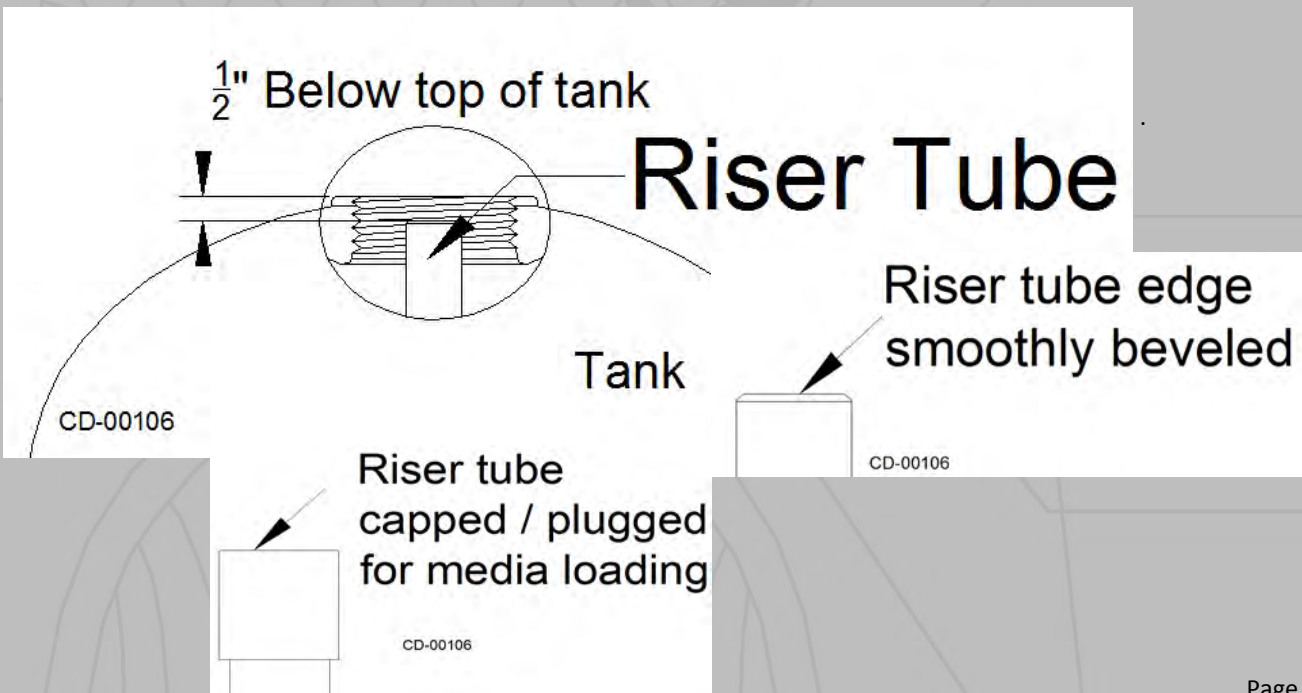

Media Loading

Section 5.0

- Different medias have different loading instructions. Confirm which filter type you have before proceeding. **For example the manganese greensand filters, must have a potassium permanganate or chlorine soak.** See following page before you start loading the media. **The chemical free filter must have an extended backwash as soon as possible after water has been added to the tank or the media bed could cement.** *On the chem free filter it is recommended that the piping is completed before loading the media.*
- Check the location and orientation of the tank. Ensure the tank is in the proper location so the unit connections will line up correctly with the piping. If required, test fit the valves & manifolds to be sure. If the unit has a side mounted manifold, occasionally tank shims are required between the tank and the floor to ensure piping / manifold will have a **minimum** of 1/2" clearance. If required, install shims before starting to load the tank. Make sure the tank is properly installed (tripod base tanks should be secured to the floor). It is very difficult to move a tank once the media has been loaded and may damage the tank.
- Fill the tank approximately 1/3 full of water. This will help protect the laterals from the media being poured in. Distributions tend to float up once water has been put into the tank so confirm that the distribution is being held on the bottom of the tank and is centered. Confirm the riser tube is plugged so no media will enter the distribution.
- Check the media list and start from the bottom up. Ensure the proper amount of each type of media before moving on to the next media. It is common to have additional partial bags to add up to the required quantity of each media.
- The support bed media is first (coarse gravel first, then medium gravel followed by fine gravel etc.). Pour the gravel so it is evenly spread out in the tank (use a circular pouring pattern). Note that the gravel will not level out on its own when backwashed. It must be manually levelled. To check the level, the water can be drained down until the media just starts to poke through the water surface. This will help determine if the media is level. The most important layer to get as level as possible is the top of the support bed, the fine gravel. The gravel will not move during backwash. If, for example, all the gravel has been poured to one side, the unit will not have even flow distribution and the unit will not perform as intended.
- Once all the media has been loaded, unless there are special instructions not to, the media tanks should be filled with water to allow the media time to soak. If possible allow the media to soak for several hours, preferably over night.

Media Loading

Section 5.0

Once all the media has been loaded, unless there are special instructions not to, the media tanks should be filled with water to allow the media time to soak. If possible allow the media to soak for several hours, preferably over night.

Manganese Greensand Filters Only—Chemical Soak

- The manganese greensand media is not fully regenerated when shipped. The greensand requires conditioning before placing the units into service. A chemical soak must be completed . Potassium permanganate soak is the most common, but chlorine can be used as well.

- *Note: It is imperative that the manual isolation valve on the filter outlet be fully closed for the duration of the soaking process. Once the soaking process is complete, remember to fully backwash the media bed until the effluent running to the drain runs clear. It is critical that the filter be properly backwashed during start-up. Inadequate backwash of the filter may result in inferior operation of the filter during service.*

Potassium Permanganate (KMnO₄) Soak

- Note: A wet and dry vacuum is recommended for the best results.

- Use potable, clear water for the soak.

- Dissolve approx. 4 ounces of potassium permanganate per cu. ft. of greensand in a container of water. A recommended solution strength for the treatment soak is 4 ounces of potassium permanganate per 1 to 2 US gallon of dilution water. Check section 5, “Media Specifications”, for the quantity of greensand in each filter size.

- *Note: It is important that the potassium permanganate be totally dissolved in water before being added to the filter. Any undissolved crystals will result in pink water continually bleeding out of the filter. Use cold water to dissolve the KMnO₄. If hot water is used, the KMnO₄ could fall out of the solution when it contacts the cold bed.*

Using a wet and dry vacuum, do the following:

-Fill the filter with water until the water is at the top of the media bed. Pour the KMnO₄ evenly over the top of the bed.

-Use the wet/dry vac to draw water up through the riser tube. Stop as soon as some pink starts to show up in the water.

- Refill the tank by putting water slowly down the riser tube until the water rises to approximately 3” above the top of the media bed

No wet & dry vacuum

- Start with very little water in the filter.
- Pour the potassium permanganate solution into the tank on top of the media.
- Begin filling the tank down the riser tube with water until the water level in the tank is approximately 3 inches above the level of the media bed.

- Allow the filter to stand for a minimum of 3 hours. Ideally, it is recommended the filter be left to soak until the filter is to be placed into service or at least overnight if possible.

- Chlorine can also be used instead of potassium permanganate. Use 4 oz of chlorine (12%) per cubic foot of greensand.
- With chlorine, start with very little water in the filter.
- Pour the chlorine solution into the tank on top of the media.
- Begin filling the tank down the riser tube with water until the water level in the tank is approximately 3 inches above the level of the media bed.

Allow the filter to stand for a minimum of 3 hours. Ideally, it is recommended the filter be left to soak until the filter is to be placed into service or at least overnight if possible.

Media Descriptions

Section 5.1

Media	Description	Density (lb/ft ³)
Anthrafilt	Graded anthracite coal aggregate. Black in color.	52
Fine Filter Sand	Finely crushed glacial deposit	100
Fine Garnet	Almandine garnet crushed to an effective size of 0.37 mm. Red/violet in color.	125
Coarse Garnet	Almandine garnet crushed to an effective size of 1.22	140
Manganese Greensand	Purplish-Black media processes from Glauconitic green-sand.	85
Calcium Car-	crushed and screened white marble	90
Magnesium Oxide	processed bead-like magnesia	82
Activated Carbon	Granular activated carbon, made from bituminous coal.	23
Fine Gravel	1/8" x 1/16" graded and washed quartz (50 lb bags)	100
Medium Gravel	1/4" x 1/8" graded and washed quartz (50 lb bags)	100
Coarse Gravel	1/2" x 1/4" graded and washed quartz (50 lb bags)	100

Media Beds Quantities

Section 5.2

Special Media Loading, (Optional)

Section 5.2.1

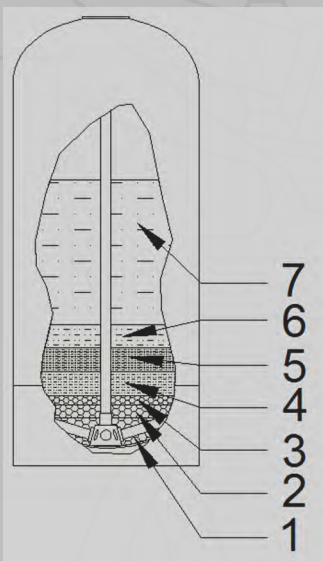

Layer	Media	Quantity
1 Bottom Layer		
2		
3		
4		
5		
6		
7		
Top Layer		

Media Beds

Section 5

5.2.3 MM Media Bed

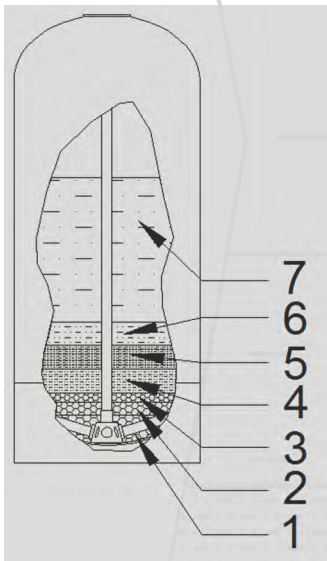

Multi-media (FT ³)									
Tank Size	Part Number	Coarse Gravel	Medium Gravel	Fine Gravel	Coarse Garnet	Fine Garnet	Filter Sand	Anthracite	Weight (LBS)
		#1	#2	#3	#4	#5	#6	#7	
10	P450010	0	0	0.12	0.09	0.1	0.13	0.9	138
12	P450012	0	0	0.16	0.25	0.25	0.25	1	199
14	P450014	0.2	0.25	0.25	0.35	0.35	0.35	1.6	321
16	P450016	0.3	0.3	0.3	0.5	0.5	0.5	2	417
18	P450018	0.4	0.4	0.4	0.6	0.6	0.6	2.6	514
21	P450021	0.5	0.5	0.5	0.8	0.8	0.8	3.6	669

5.2.4 AC Media Bed

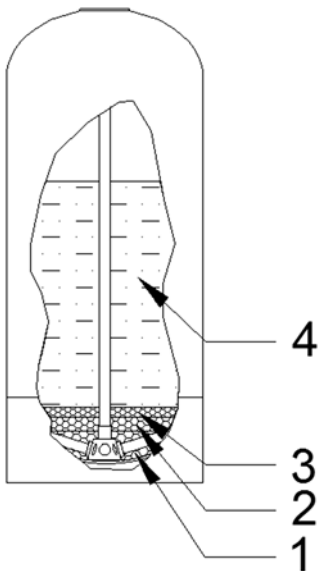

Carbon (FT ³)						
Tank Size	Part Number	Coarse Gravel	Medium Gravel	Fine Gravel	Carbon	Weight (LBS)
		#1	#2	#3	#4	
10	P450410	0	0	0.12	1.50	85
12	P450412	0	0	0.16	2	100
14	P450414	0.2	0.25	0.25	2.75	171
16	P450416	0.3	0.3	0.3	3.5	207
18	P450418	0.4	0.4	0.4	4.5	259
21	P450421	0.5	0.5	0.5	6	322
24	P450424	0.5	0.5	1	8	416

*24" Carbon Non standard

5.2.5 MG Media Bed

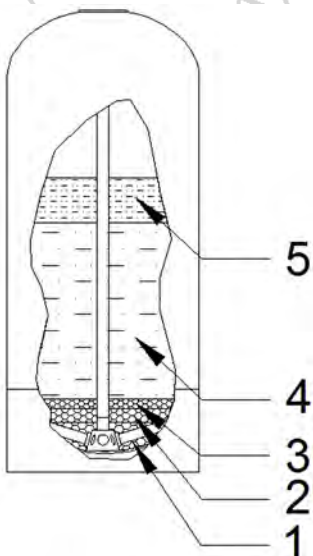

Greensand (FT ³) *Note: Requires KMnO ₄ Soak*							
Tank Size	Part Number	Coarse Gravel	Medium Gravel	Fine Gravel	Manganese Greensand	Anthracite	Weight (LBS)
		#1	#2	#3	#4	#5	
10	P450510	0	0	0.12	1	0.25	150
12	P450512	0	0	0.16	1.75	0.35	223
14	P450514	0.2	0.25	0.25	2	0.5	306
16	P450516	0.3	0.3	0.3	2.8	0.7	404
18	P450518	0.3	0.25	0.25	3.5	0.9	464
21	P450521	0.5	0.5	0.5	4.75	1.25	659

Manganese greensand does not come fully regenerated. Review Section 5.9 before loading greensand bed.

Media Beds

Section 5

5.2.6 CF Media Bed

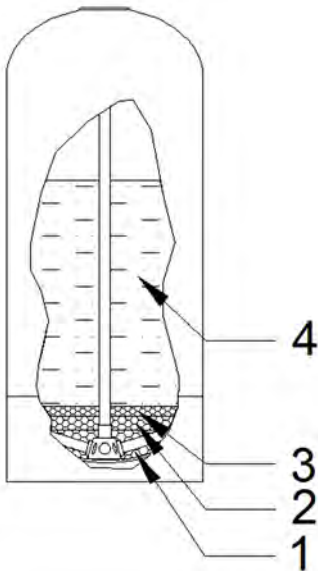

Chem Free (FT ³)								
Note: Media Requires Immediate Backwash To Prevent Cementing								
Tank Size	Part Number	Coarse Gravel	Medium Gravel	Fine Gravel	Filter Sand	Mag Oxide	Calcite Carbonate	Weight (LBS)
		#1	#2	#3	#4	#4	#4	
10	P450610	0	0	0.12	0.3	0.08	1	178
12	P450612	0	0	0.16	0.4	0.09	1.32	222
14	P450614	0.25	0.25	0.25	0.6	0.14	1.9	354
16	P450616	0.3	0.2	0.2	0.85	0.21	2.1	400
18	P450618	0.3	0.2	0.2	1.1	0.23	3.1	516
21	P450621	0.5	0.3	0.3	1.5	0.34	4	685

**Note. This media requires immediate backwashing to prevent the bed from cementing, once the media becomes wet. A long initial backwash is required to fully mix the filter sand, the mag oxide & the calcium carbonate into a "salt & pepper" mix. Once the bed is wet, do not drain down the media bed. **

5.2.7 BF Media Bed

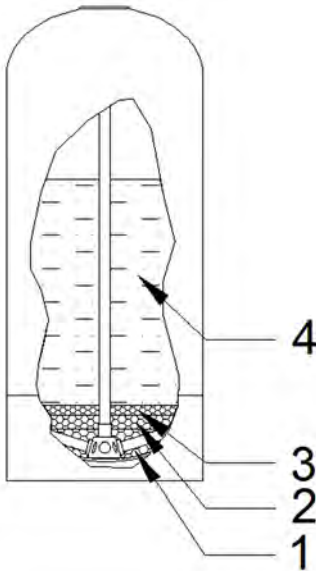

Birm (FT ³)						
Tank Size	Part Number	Coarse Gravel	Medium Gravel	Fine Gravel	Birm	Weight (LBS)
		#1	#2	#3	#4	
10	P450810	0	0	0.12	1.3	104
12	P450812	0	0	0.16	1.75	151
14	P450814	0.2	0.25	0.25	2.5	215
16	P450816	0.3	0.3	0.3	3.5	270
18	P450818	0.3	0.3	0.3	4.5	330
21	P450821	0.5	0.5	0.5	6	430

5.2.8 NX Media Bed

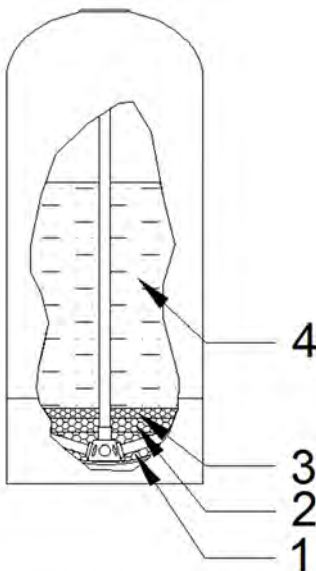

Nextsand (FT ³)				
Tank Size	Part Number	Medium Gravel	Nextsand	Weight (LBS)
		#1	#2	
10	P450910	0.12	1.5	100
12	P450912	0.16	2	146
14	P450914	0.7	2.75	261
16	P450916	1	3.5	333
18	P450918	1.2	4.5	408
21	P450921	1.5	6	520

**Nextsand is temperature sensitive in relation to backwash rates. The warmer the temperature of the backwash water, the higher the recommended backwash rate. See section 5.10 for backwash table vs temperature.

Start-up

NOTE: It is important to follow the startup instructions as improper start up may result in unsatisfactory filter operation or possibly damage the filter.

Piping Inspection

Section 6.0

Before starting up the unit check and confirm the following:

- All system piping is correct. (inlet to the valve inlet, outlet to the valve outlet, etc.) and all connections are complete, (see installation drawing).
- There are flex connections between the control valve and the piping (if required) and that there are vacuum breakers to protect the mineral tanks.
- Ensure that all of the manual isolation and by-pass valves are closed prior to start up
- The valve has the proper drain line flow control and the drain line has a proper air gap.
- Check all electrical connections and ensure that they are correct and complete.
- **If this is a greensand filter, a media bed chemical soak MUST have been completed. See section 5**

Start up Programming

Section 6.1

-Confirm the valve programming is correct. (See section 8). Usually the programming has been adjusted at the factory, and in most cases, the only items that may require adjustment is the time of day for the regeneration to occur and the time period between regenerations. Normally the factory setting for filters is every 3 days.

Condensed standard filter programming for a clock unit

If your main screen looks like below, this is how to set the number of days

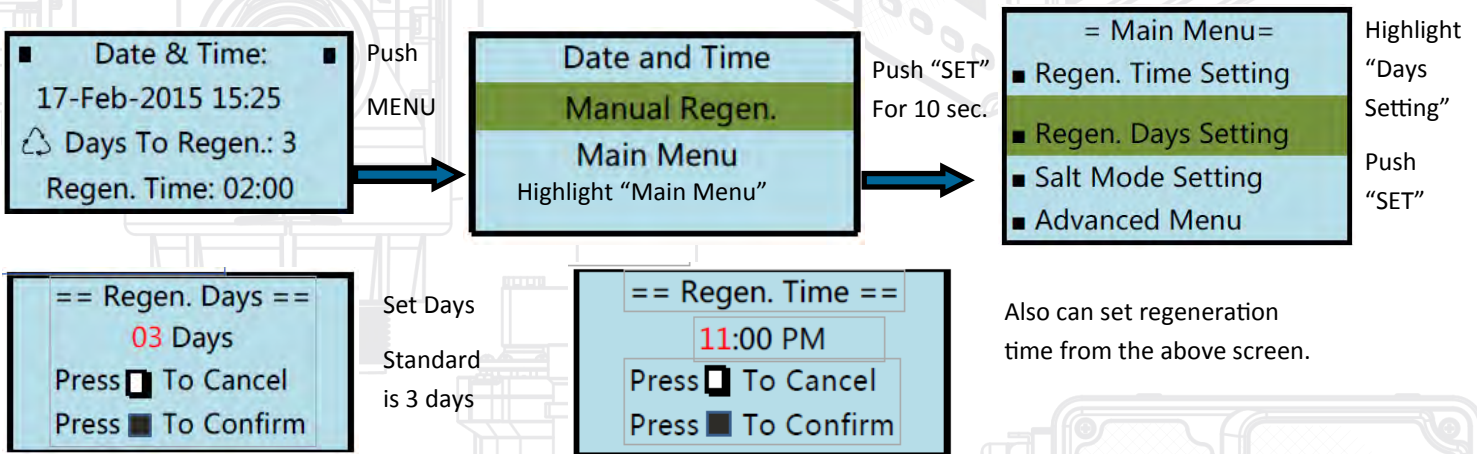

- If your screen looks like anything else, see next page.

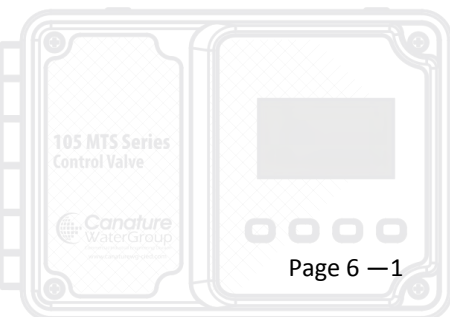

Condensed standard filter programming for a clock unit

- If the menu looks like this and converting to clock.

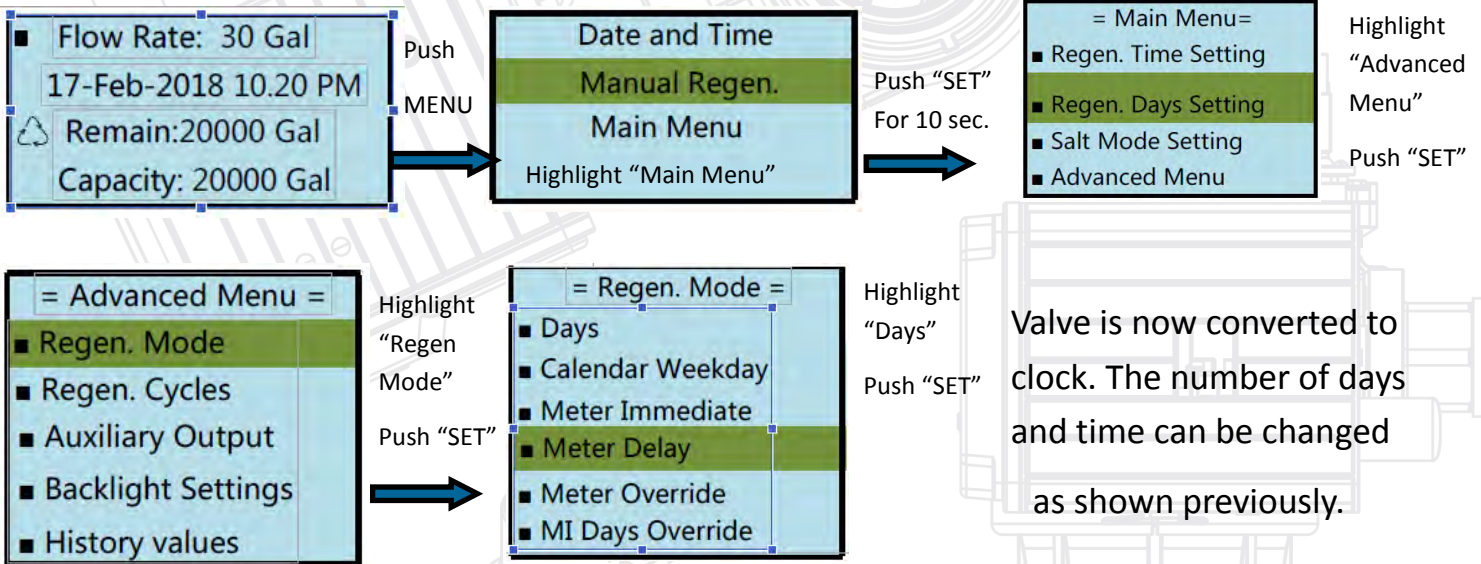

- Once everything has been checked and confirmed correct, manually advance the valve into backwash position. To do this on the 105 valve, push and release the "Set " button on the control valve. Once the control valve moves into the backwash position, unplug the control valve. This way the valve will stay in the backwash position, allowing to slowly fill the tank with water from the bottom on up. The 105 has a dial on the side of the valve to indicate what position it is in.

- **Slowly** partially open the inlet isolation valve, and allow the filter to slowly fill with water. When the filter is full, water begins to run out through the drain. **If the unit is filled too quickly, the media could be blown out, as well as possible damage the filter.** When full, close the inlet valve.

- Allow the filter to stand for 1-2 hours once the tank is full to saturate the media bed if this has not already been done during the media loading (see section 5)

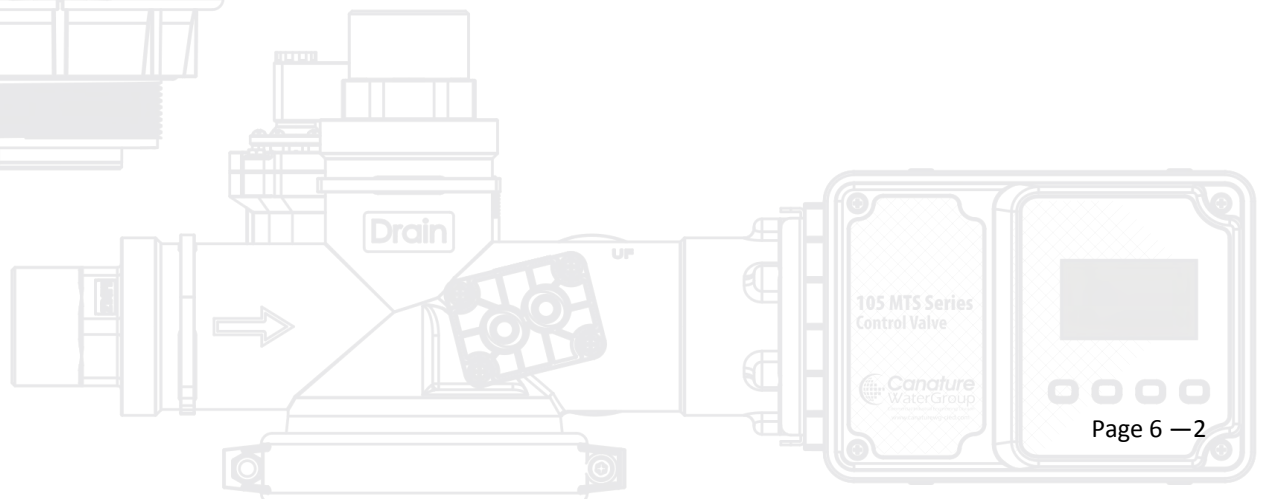

Regenerating The System

-Once the media is fully saturated, the actual unit regeneration can occur. With the unit still in the backwash position, slowly start opening the inlet isolation valve. If the unit still has any air inside, it will sputter out. Constantly check the drain water and ensure only fines from the media bed is being backwashed out. If the drain water contains more than fines, reduce the backwash flowrate by throttling the inlet isolation valve. Any traces of air in the media bed can result in backwash the media out. If this is occurring, close the inlet isolation valve and allow the media to soak a little longer. Later, gradually fully open the inlet isolation valve. The backwash flow controller will limit the flow to drain. Allow the unit to backwash until the waste water clears up and there is no colour or fines still being removed. This process may take 20 minutes or more.

-If this is a manganese greensand filter, ensure all chemicals from conditioning the media is backwashed .

-Once completed, close the inlet isolation valve.

- With the inlet still closed, plug the unit back in. The valve may cycle back to the home position. If so initiate a regeneration again by pressing the SET button on the valve.

- Check all steps in the regeneration cycles and confirm the system is operating as intended.

- Upon completion of the steps above, if the filter is not a greensand filter or a chemical free filter, the unit outlet isolation valves are **slowly** opened.

-The system bypass valve should then be closed. The system and piping should now be properly flushed. After this the system is now ready for normal service operation.

- Test the service water and confirm the system is operating properly.

- If the filter is a greensand filter or chemical free filter, see the following section.

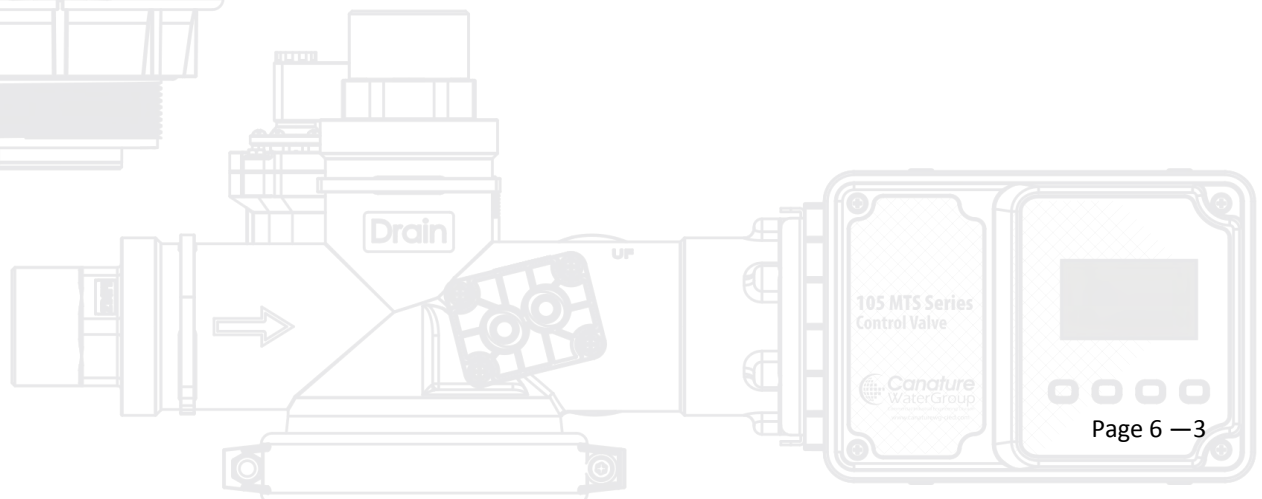

Chemical Injection Pump Start-Up, (Manganese Greensand Filters only) Section 6.2

-Check the chemical pump system and ensure it has been correctly installed as outlined in the chemical pump manual.

-Note: The chemical pump must be set up in a manner that it only operates when the system is in operation. On many systems, the chemical pump is wired in with the well pump so that it only runs when the well pump runs. On systems that the service flowrate varies, typically a contacting meter and a contacting type chemical pump is used to vary the amount of chemical (KMnO_4) injected for the different flowrates. It is very important not to overfeed or underfeed the chemical as both conditions result in unsatisfactory operation. Overfeed can lead to “pink” service water, and underfeed can lead to damaging the media bed.

- Mix up a small amount (2 gallons) of potassium permanganate (KMnO_4) solution for the chemical feed system. To estimate the potassium permanganate solution strength, a few calculations must be done.

-Estimate required dosage; calculated by using the raw water analysis and multiplying the level of iron by 0.7 and the level of manganese by 1. Example: 2 ppm of iron and 0.5 ppm of manganese has a required dosage of $(2 \times 0.7) + (0.5 \times 1) = 1.9$ ppm required dosage

-Calculate 75% of rated capacity of the chemical pump. This is done because it usually desirable to try to operate the chemical pump at around 75% of it's rated capacity. This will help keep maintenance to the chemical pump to a minimum by keeping the stroke fairly long (as this helps keep the check valves cleaner) and still allow some adjustment. Example: The standard chemical pump commonly used is the 12 GPD (gallon per day) pump so the rating you would like to use is $0.75 \times 12 = 9$ GPD

The estimated solution strength is now calculated by the following formula:

$$\frac{\text{SERVICE FLOWRATE (USGPM)} \times \text{REQUIRED DOSAGE (PPM)} \times 1440}{\text{RATED PUMP CAPACITY}} = \text{SOLUTION STRENGTH (PPM)}$$

Example: for system running at 60 USGPM, 2 ppm of iron and 0.5 ppm of manganese and a chemical pump rated at 12 USGPD

$$\frac{60 \text{ (USGPM)} \times 1.9 \text{ (PPM)} \times 1440}{9 \text{ (USGPD)}} = 18240 \text{ SOLUTION STRENGTH (PPM)}$$

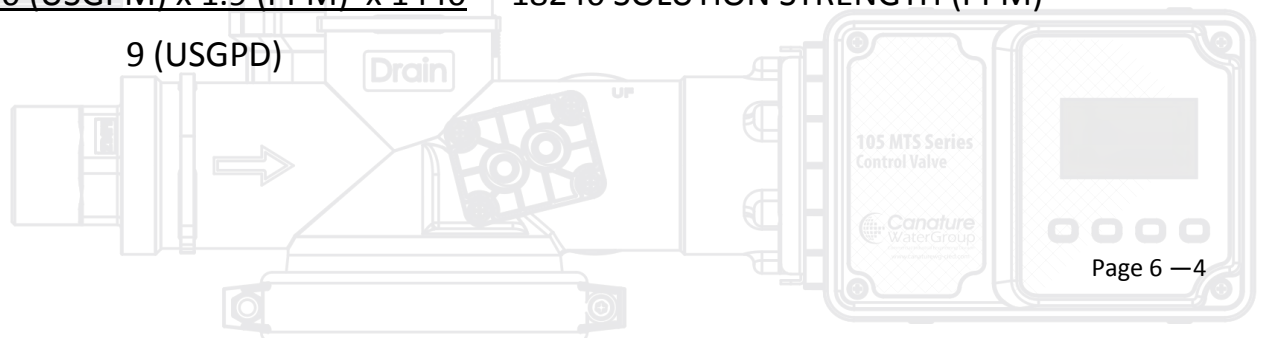

- Solution Strength chart

oz of KMnO4 in 1 USGallon of water	Solution Strength (PPM)
1	7,500
2	15,000
3	22,500
4	30,000
5	37,500

-Make sure your mix water does not contain any iron or manganese as it will precipitate out as a sludge and can plug up the chemical feeder. The reason for initially mixing up a small amount, is that depending upon the water conditions and flowrates, the solution strength will vary. This only gives you a typical starting point and the final solution strength that works for your application may be quite different.

Temperature °F	Solubility in distilled water wt oz/US gallon
32	3.7
68	8.6
104	16.7
140	30.7

To start up and prime the pump, plug the chemical pump into a power source.

Solenoid Pump

- *Note: If the pump is a solenoid style pump DO NOT adjust the stroke length while the pump is turned off, or not operating. Doing so will damage the internal pump mechanism. Adjustment of the stroke length must only be done while the pump is in operation.*

- To prime the pump, turn the bleed valve assembly counter clockwise to bypass the pump discharge from the pressurised destination to the recirculation tubing running back into the tank. Allow the pump to run in this position until the injection fluid is visible running back into the tank. Once this occurs return the bleed valve into the normal position, allowing the injection chemical to flow towards the pressurised destination. All air must be purged from the pump head before the pump will pump against a pressurised flow stream. Once the pump has been primed, reconnect the chemical pump into the system’s control circuit.

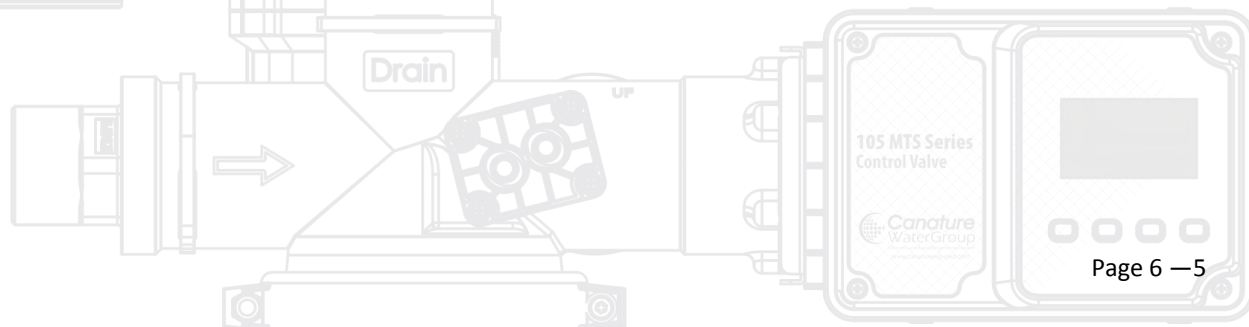

- Once in operation, the injection rate is varied by adjusting the stroke length of the injection pump until the desired dosage rate is achieved. On the pump the length of the displaced stroke during the movement of the pump diaphragm can be adjusted between 0% and 100%. For efficient and reliable operation of the pump, it is recommended that the stroke length be between 60% to 80%. Shorter strokes than this may not keep the injection fittings clean, and result in plugging the injection system, preventing further injection. Shorter, more rapid strokes will also wear out the internal drive mechanism faster than if longer, slower strokes are used.
- With the filter in service, adjust the chemical dosage rate and the chemical solution strength until the three factors below are satisfied:
 - Influent water has a slight pink colour to it immediately before the filter.
 - Filtered effluent water is clear, with no remaining pink colour to it.
 - Filtered effluent water has acceptable levels of iron and manganese present.
- To ensure the chemical is not being underfed, it is recommended that the system to be slightly overfed until pink is coming through and then gradually cut back on the chemical feed until the effluent become clear.
- If using chlorine, there must be at least a 0.5 ppm of free chlorine coming out of the filter or the coating of the media will be stripped off.

Hydro-Charger Set-Up, (Chemical Free Filters only)

Section 6.3

- Upon completing the filter start-up detailed above, the hydrocharger must be configured in order to draw in enough air in order to oxidize the iron in the water supply. Initially, ensure that the throttling pin located on the side of the hydrocharger (air injector) is turned out fully, allowing for unrestricted flow through the internal venturi bypass.

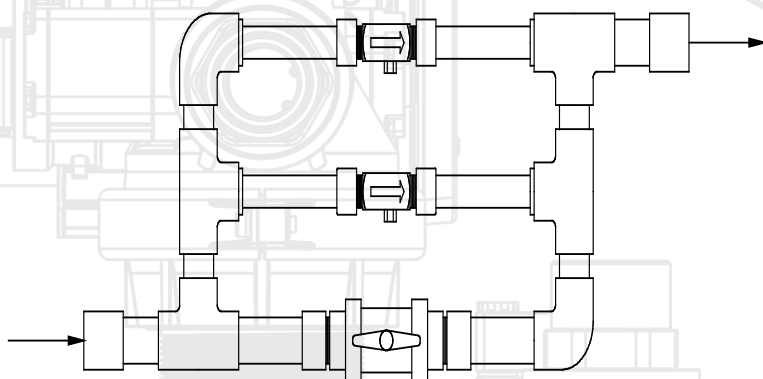

Using Hydrochargers

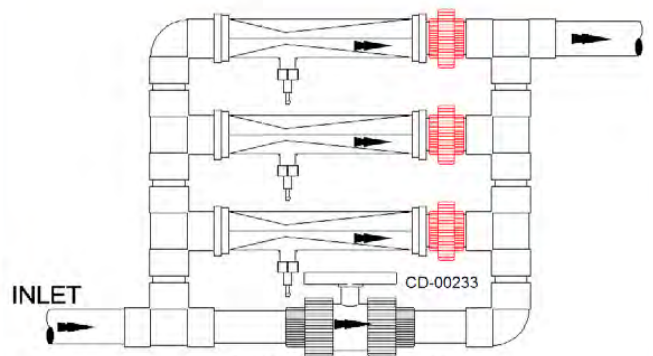

Using Mazzie Ventures

Air Draw Hydrocharger Bank

- Note: Hydrocharger shown above is for a typical filter systems. Larger or smaller filter units use same general arrangement, but may use more or less air injectors.

- Begin flowing water through the filter(s) at the recommended service flow rate.
- Upon reaching a stable flow rate and pressure, begin closing the ball valve until all the hydrocharger venturi begins drawing air. This is indicated by either a whistling sound, or by being able to feel the air suction at the venturi inlet. Mazzi air injectors may also be used.

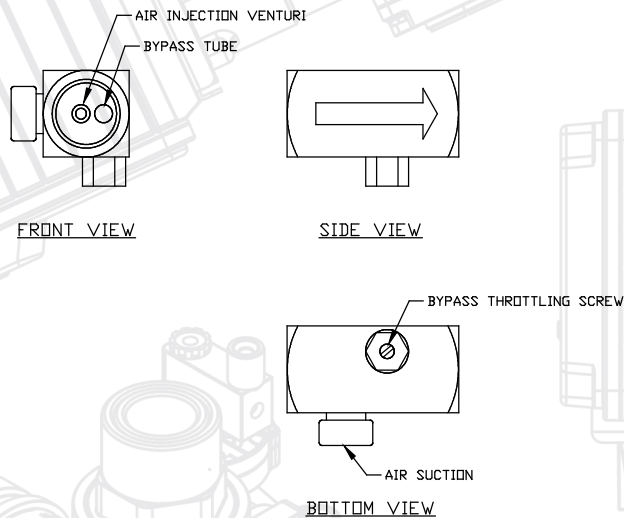

Air Injector

- Once air suction is detected, let the system stabilize at that point. Periodically monitor the effluent iron level, checking to see if the media bed is reducing the iron concentration down to an acceptable level.
- *Note: The chem free media, (which differs from all other filters), is most efficient operation occurs when the media is slightly "dirty" Once the system is in operation, care must be taken not to over backwash the chem free bed. If the bed is overcleaned, it may have to be run for a while to "dirty up" the bed to make the filter operate properly.*
- If the iron is not being adequately reduced, more water must be forced through the venturi tube. This is done by further closing the ball valve. Minor differences between hydrochargers can be adjusted by minor adjustments using the hydrocharger bypass throttling screw.
- Once again, allow the filter to stabilise at this injection rate. Repeat the water tests in determine the effluent iron concentration.
- Repeat steps 6 & 7 until the iron is being reduced down to an acceptable level.

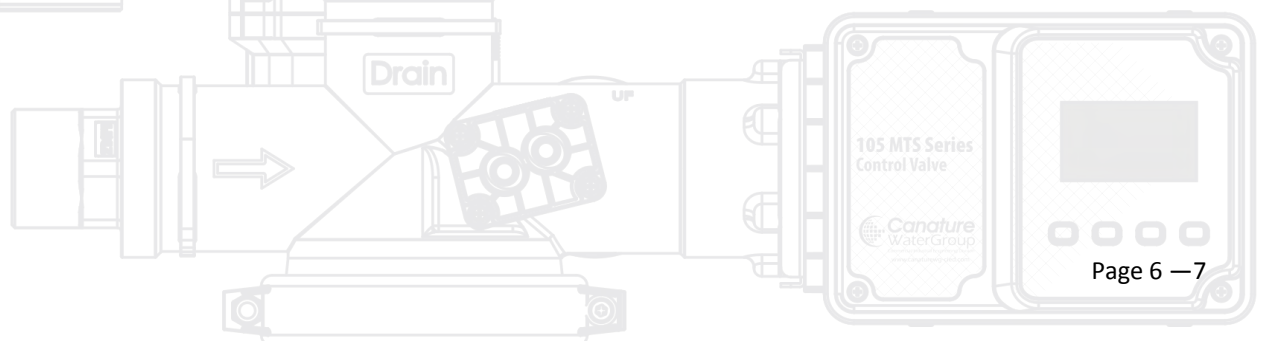

Operating Conditions

Section 7.0

For correct operation of the filter system, the minimum water pressure recommended is 30 psig, (206 kPa), in order for valve to operate effectively. ***Caution: Water pressure should not exceed 100 psig, (690 kPa), water temperature is not to exceed 100 °F, (38 °C), and the unit can not be subjected to freezing conditions.**

The manual bypass valve must always be closed and the manual inlet and outlet isolation valves open except during maintenance of the equipment.

Cycle Operation

Section 7.1

The current position of the control valve can be confirmed by the dial on the drive motor. Each cycle is indicated on the dial.

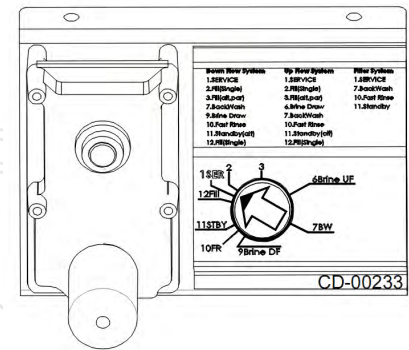

Service Position Section 7.2

During service, water is directed into the top of the tank by the control valve and flows downward through the filter media, into the distribution, and out to service. As the water flows through the filtration media, suspended particles and turbidity is removed from the raw water. As the duration of the service run increases, the filter bed accumulates particulate, and becomes "packed", increasing the pressure drop across the unit. The pressure drop can be determined by inlet and outlet pressure gauges on the filter system. Once the pressure drop reaches approximately 8 psi above the clean bed pressure drop, (at the service flow rate), the filter requires regenerating. If pressure loss through the filter begins to effect normal flow, or does not produce the quality of water required, more frequent regenerations will be required. ***Note – the exception to the pressure drop guideline is the carbon filter (which should be regenerated on time or volume).** This is position #1 on the dial.

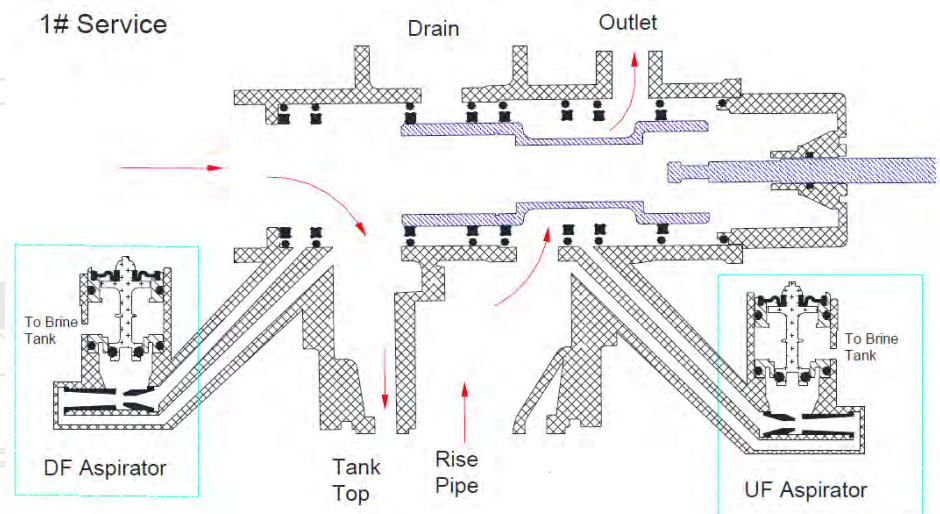

Service Position

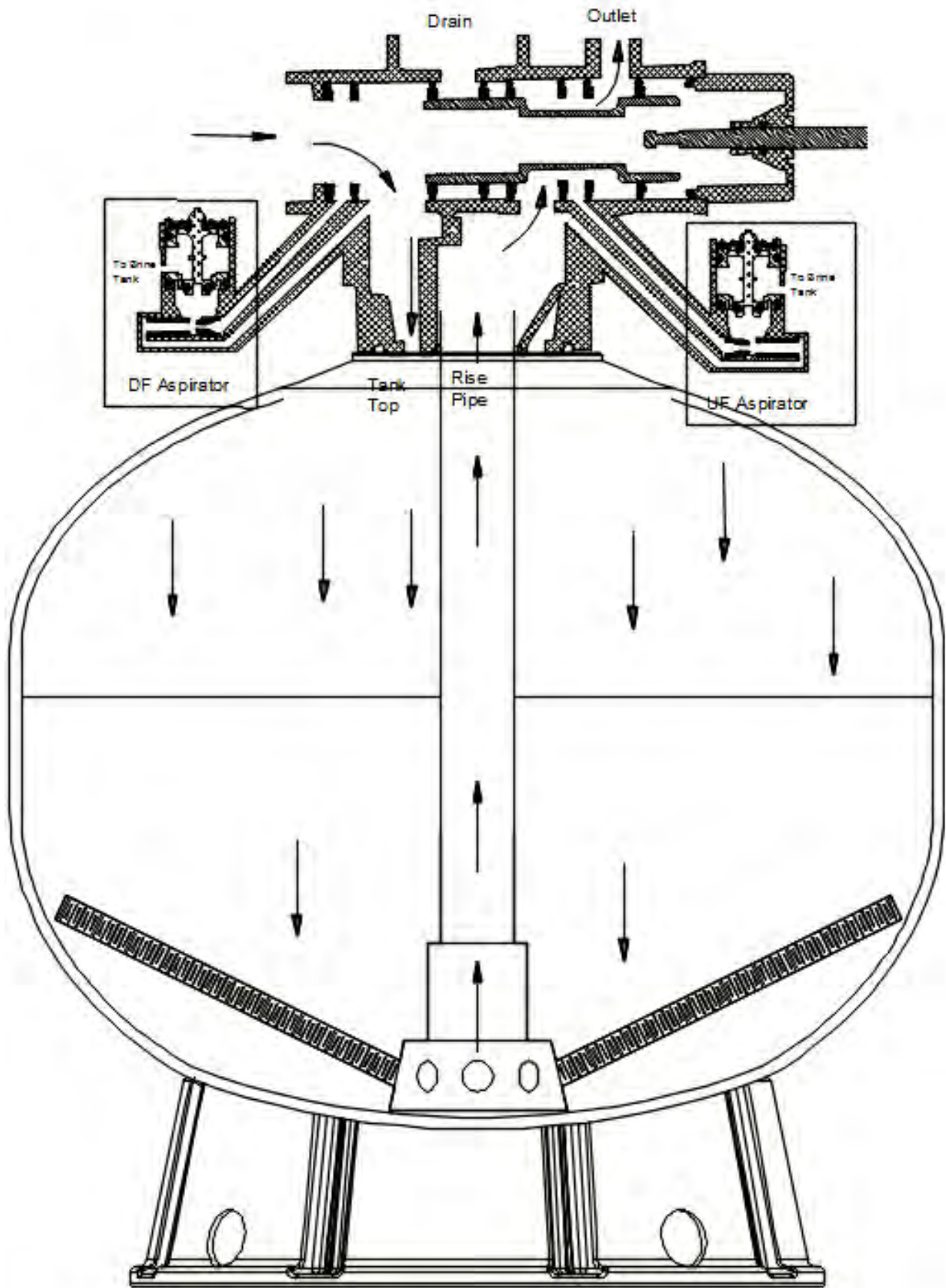

Backwash Position

Section 7.3

The regeneration procedure is performed automatically by the filter after the cycle controller is started. Each regeneration cycle consists of two steps: #1 backwash, and #2 rinse. During backwash, water is directed down the riser tube, out the bottom hub and laterals, then upwards through the filter and out to drain. This expands the filter bed, releasing the trapped particles, and cleans it thoroughly. The accumulated dirt and sediment are flushed to drain. The backwash cycle has been factory pre-set to take place for 10 minutes (except for the chemical free units which is 6 minutes). This is position #7 on the dial.

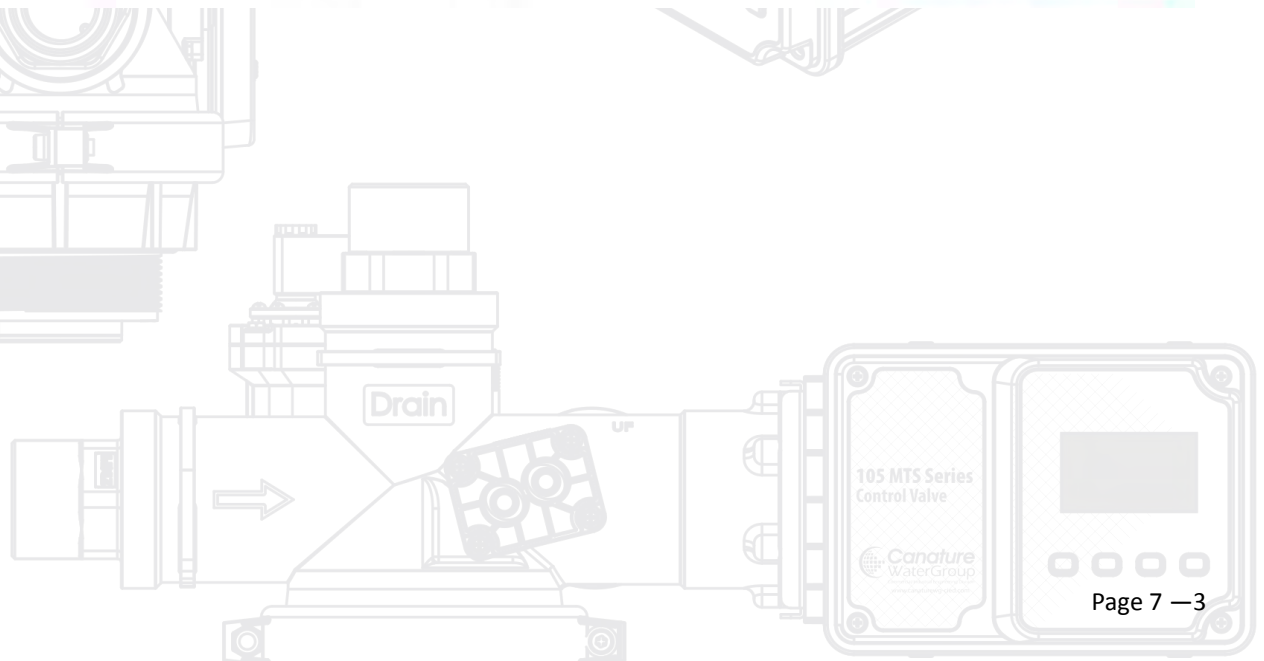
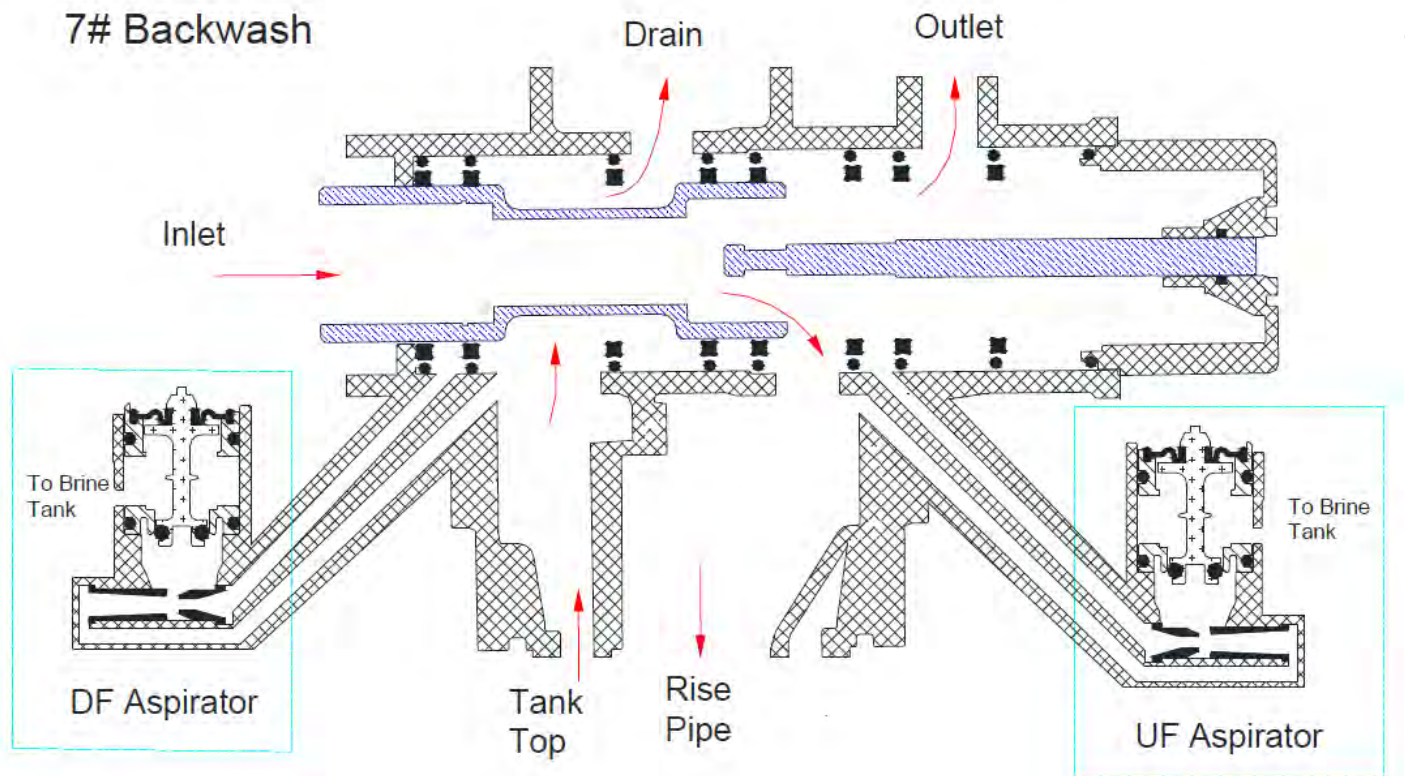

Backwash Position

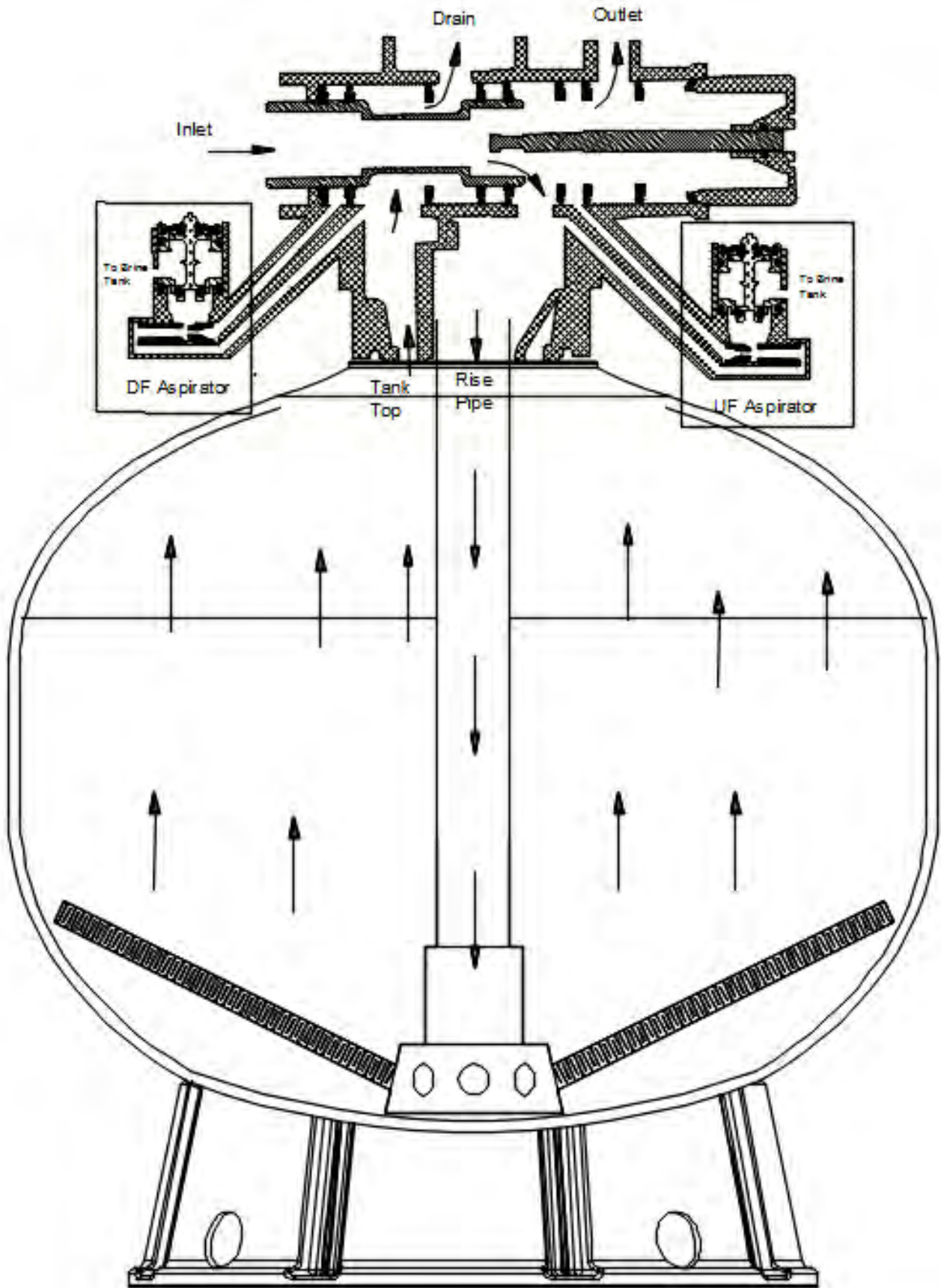

Rinse Position

Section 7.4

During rinse, water is directed downwards through the media bed, into the hub & laterals, up the riser tube, and out to drain. This reconsolidates the media bed and rinses any remaining particles in the media bed to drain. Once rinsed, the filter is ready to return to service. This is position # 10 on the dial.

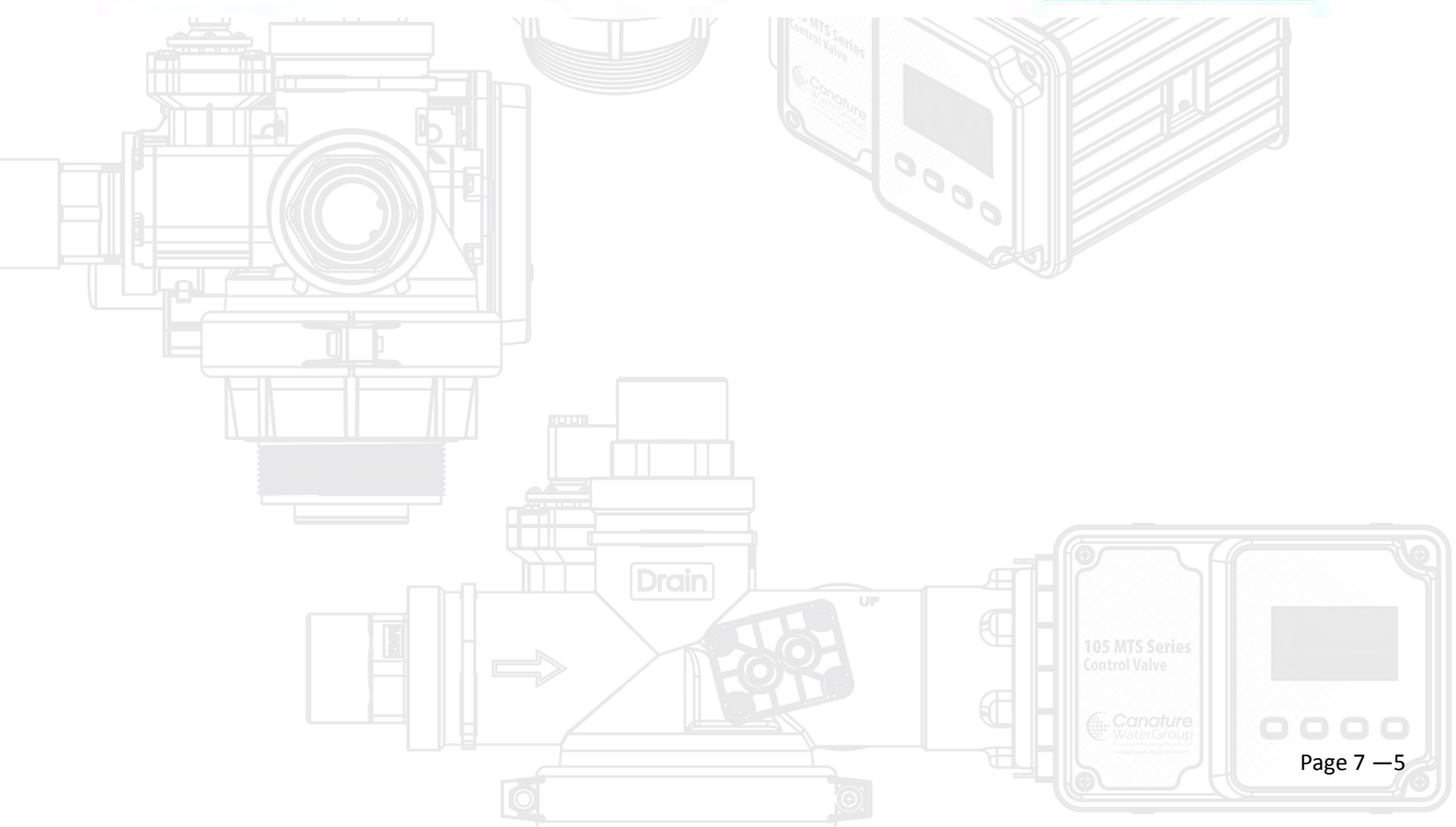
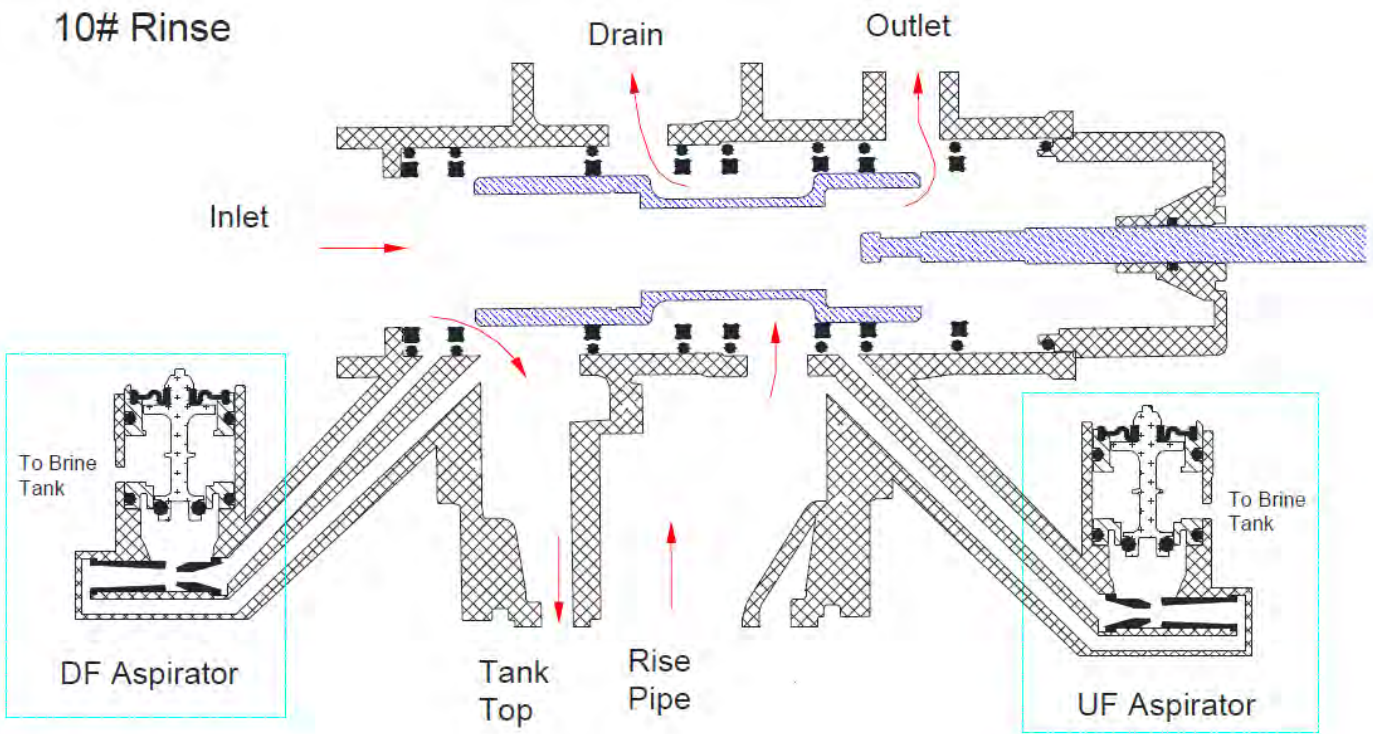

Rinse Position

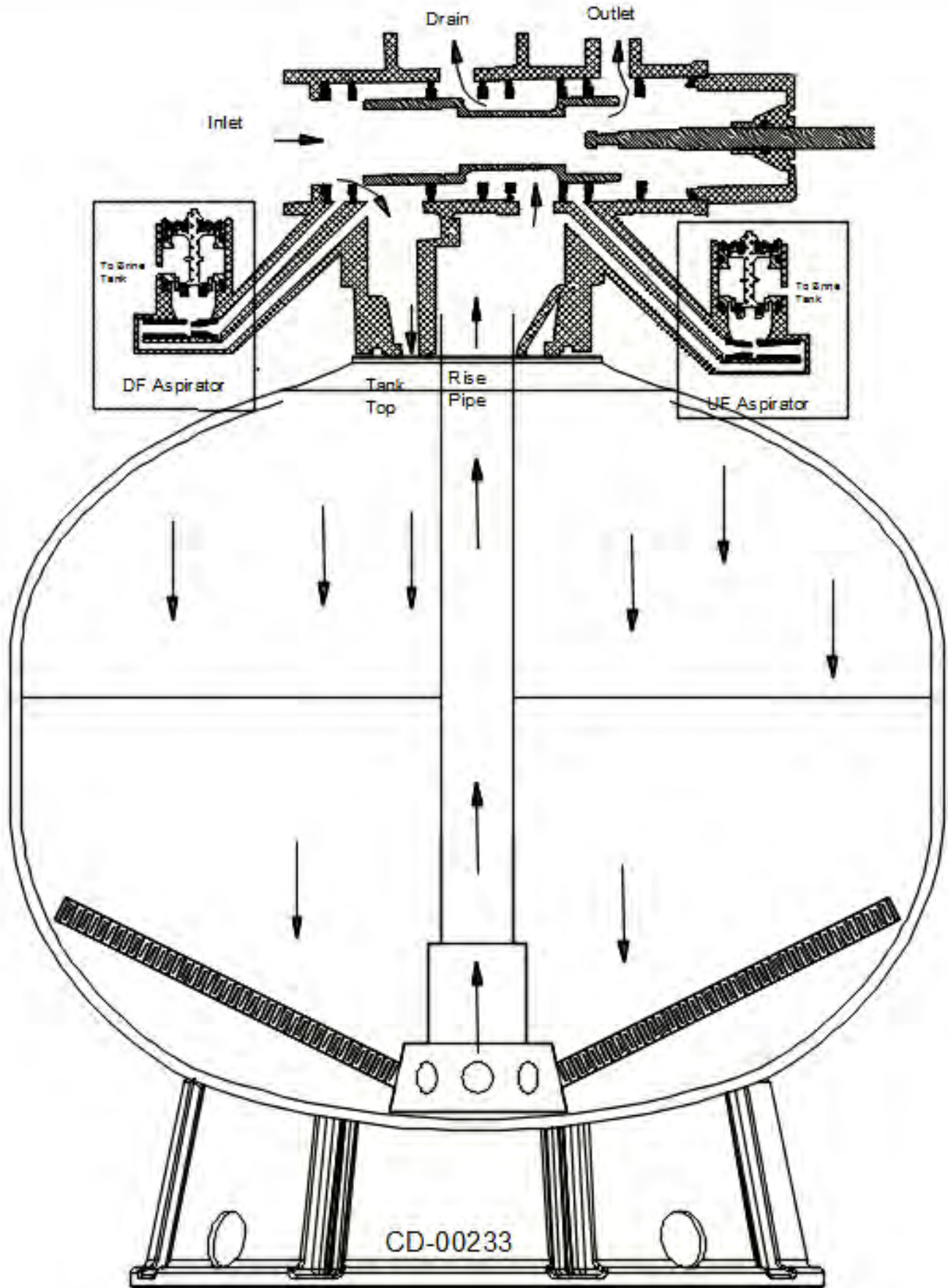

Key Pad Configuration

Section 8.0

There are four push buttons on the keypad on the 105 control valve.

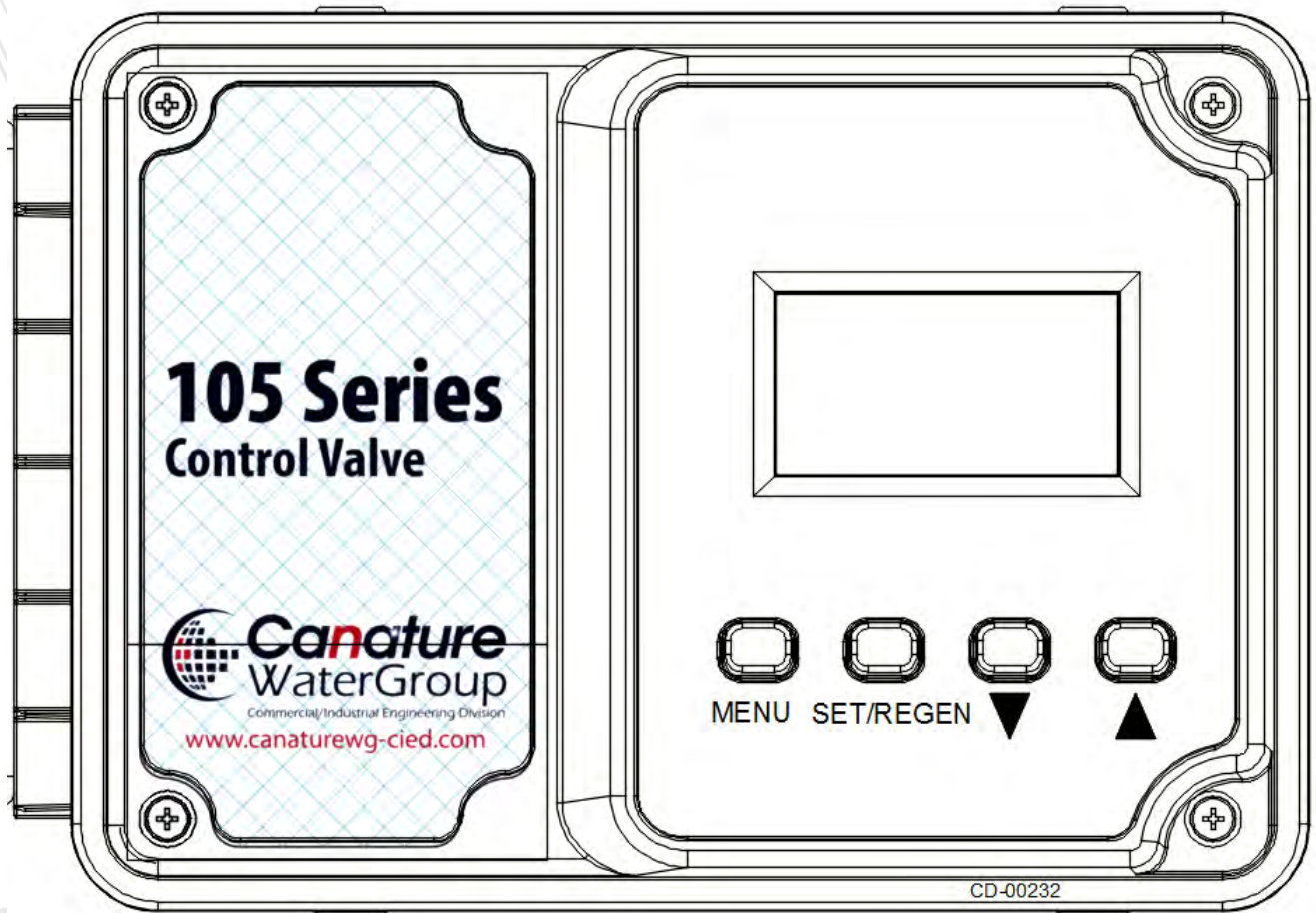

Note: MENU, SET and ARROWS will be referred to indicate which button is required to be pushed.

MENU "□": This function is to enter the basic setup information required at the time of installation, or back to previous page.

SET "■": this function is to accept the values if changed and advance the next item in the menu.

+/- "▲ ▼": These buttons are used to scroll the icon bar in the menu, and increase or decrease the value of the settings while in the programming mode.

Service Display Screen

Section 8.1

There are four push buttons on the keypad that controls all functions of the control valve.

- Service display page. On the service display screens, the main system information is displayed. Different information is displayed depending upon how the valve is programmed.

- Single tank : **Time clock unit** - *This is the factory standard for filters.*

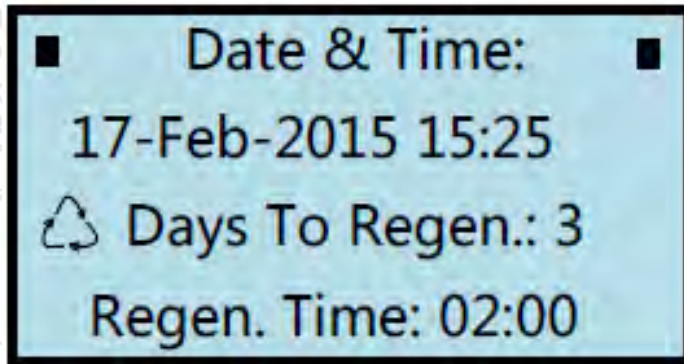

Meter initiated unit

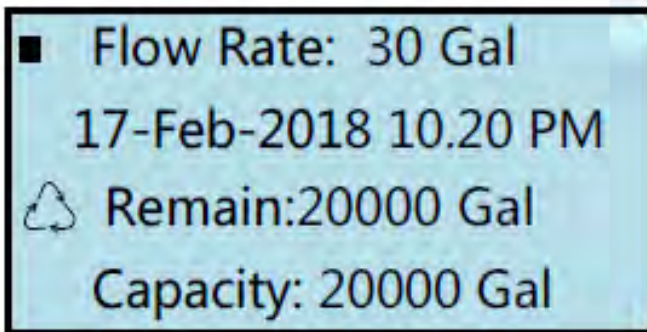

- Multi-tank interlock: (for lag valves only)

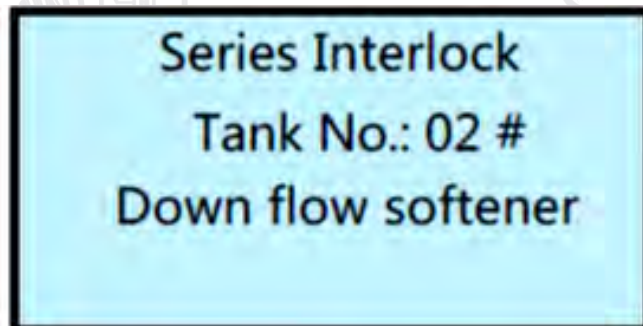

- The control will default back to the service screen if no button is pushed for 10 seconds.

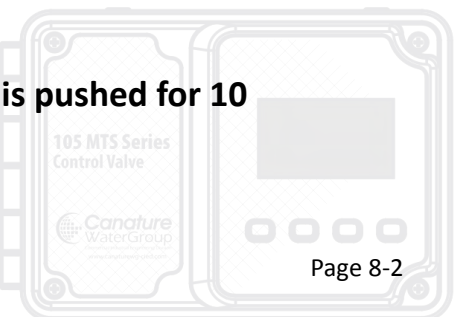

Condensed Programming For Clock Filter

Most filter are set for clock. See below for a quick guide to accomplish this.

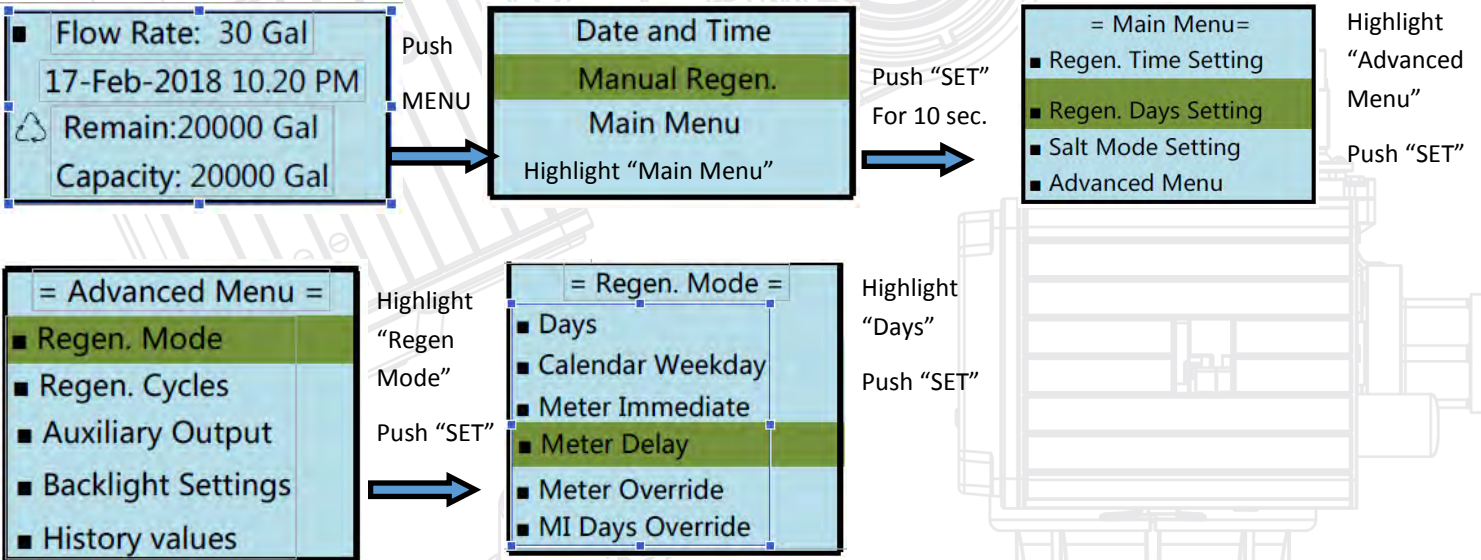

Push "MENU" button a few times until the screen is "Main Menu" again.

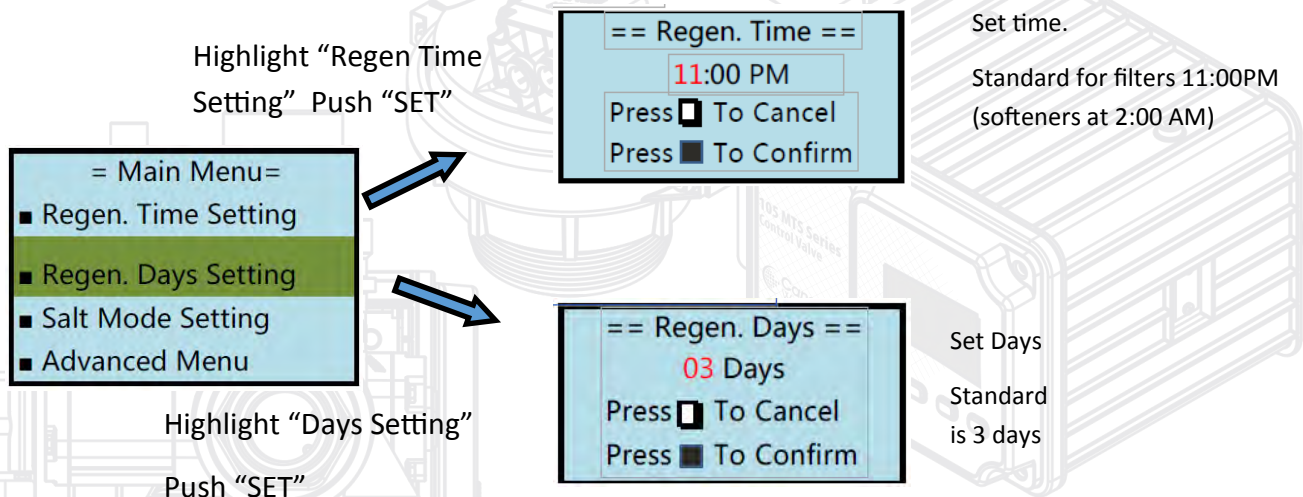

Following pages show all other programming

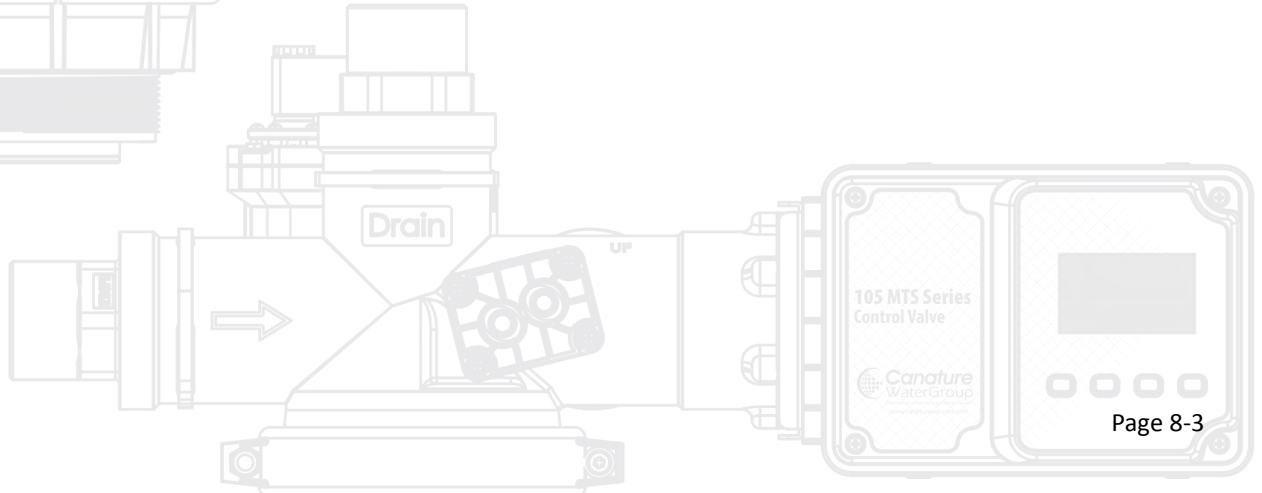

Initiating A Regeneration

Section 8.2

There are two ways to initiate a regeneration.

- Push and hold the Set/Regen button for 3 seconds and the regeneration will start immediately.
- The other is by pushing the MENU button and this screen will be displayed.

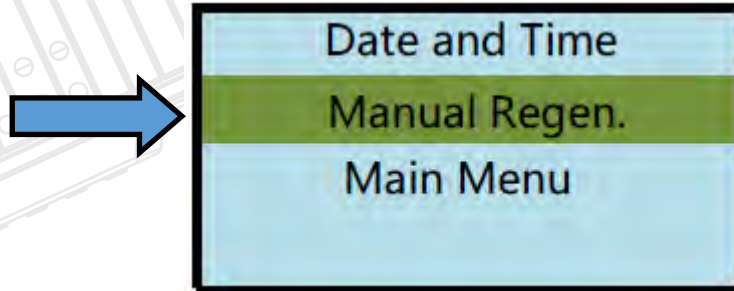

- Use the arrow button to move to the Manual Regeneration line and push SET.

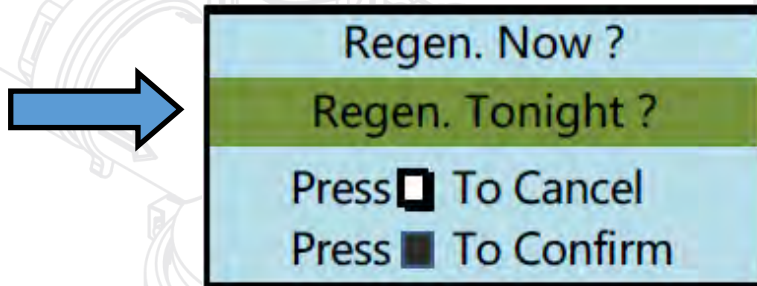

- If you move the cursor to the Regen. Now line and push the SET button, the unit will regenerate immediately.
- If the Regen. Tonight line is highlighted and push SET button, the unit will regenerate the preset time which is adjustable in the program. Also a new symbol will appear on the main service screen to indicate the unit will regenerate tonight.

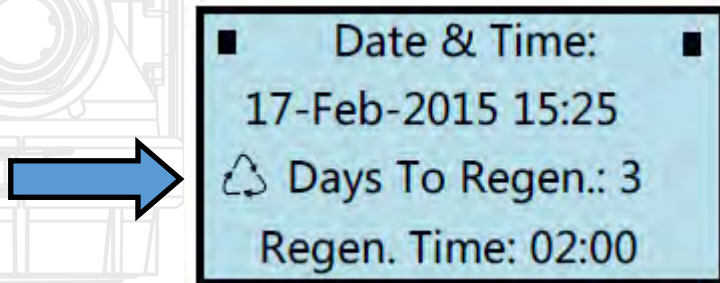

- Once the unit is in regeneration, the valve can be advanced to the next cycle by holding any button for three seconds. If a button is pressed several times in succession, (say twice for example) the valve will advance through two cycles before stopping.

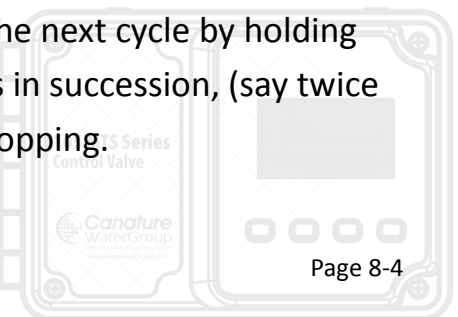

Screen Display During Regeneration

Section 8.3

- Once a regeneration has been initiated, the following screens will be displayed. Different screens will be displayed depending upon the programming of the unit.
- The display will indicate the regeneration cycle the unit is in. Also displayed is the actual time remaining before the end of the cycle. A third item displayed is the percentage of time left for the complete regeneration. For an example of this is if the total regeneration time is two hours, after one hour the display would show 50%.

Down flow softener (or air draw unit)

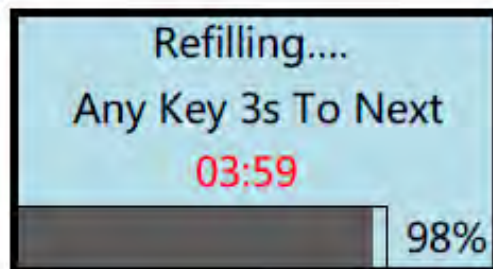
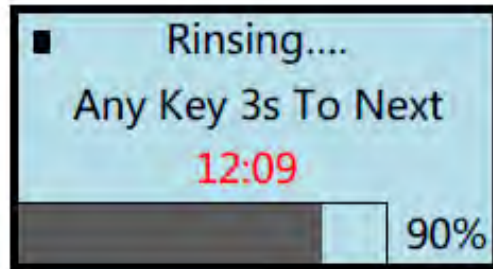
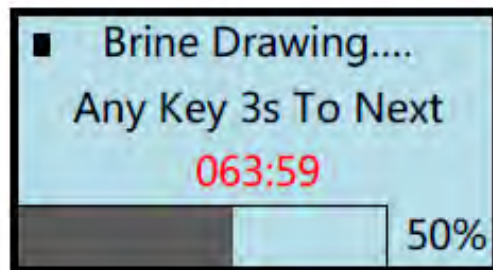
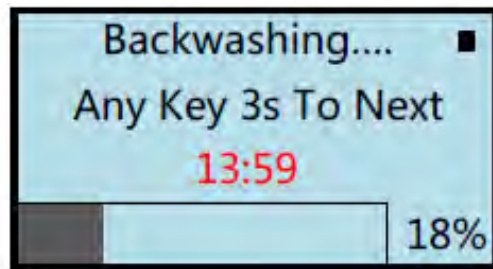

- The regeneration can be manually advanced by holding any button for three seconds.

Screen Display During Standard Filter Regeneration

Section 8.3

Filter display during regeneration

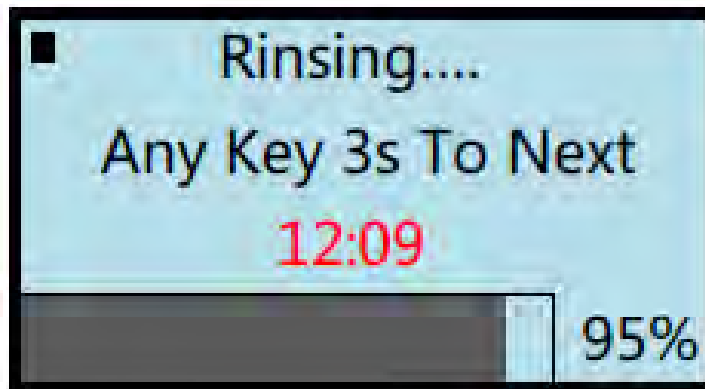
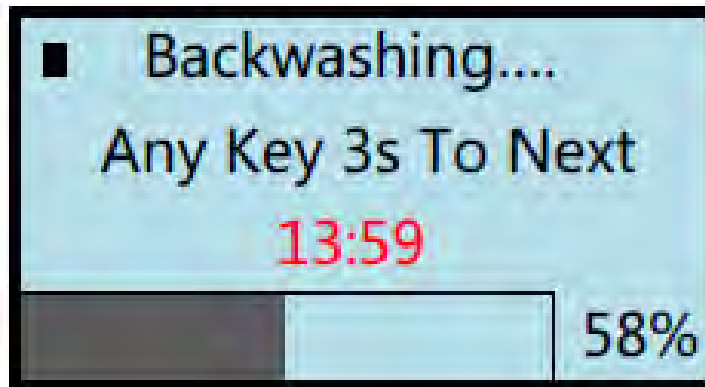

- The regeneration can be manually advanced by holding any button for three seconds

Main Menu Setup And Programming

Section 8.4

- To access the programming screens, do the following:

- Push MENU to advance to the user menu screen and use the ARROWS to highlight Main Menu.

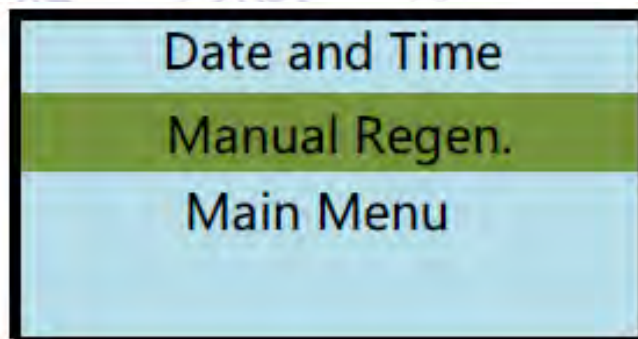
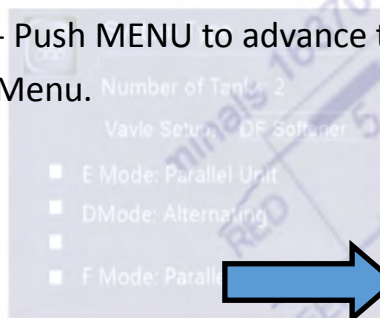

- Push and HOLD the SET button for 5 seconds until the controller beeps.

Screen Display During Regeneration

Section 8.3

- Once a regeneration has been initiated, the following screens will be displayed. Different screens will be displayed depending upon the programming of the unit.
- The display will indicate the regeneration cycle the unit is in. Also displayed is the actual time remaining before the end of the cycle. A third item displayed is the percentage of time left for the complete regeneration. For an example of this is if the total regeneration time is two hours, after one hour the display would show 50%.

Down flow softener (or air draw filter)

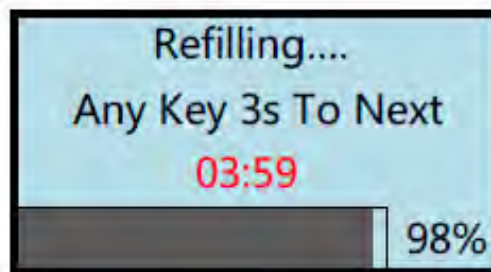
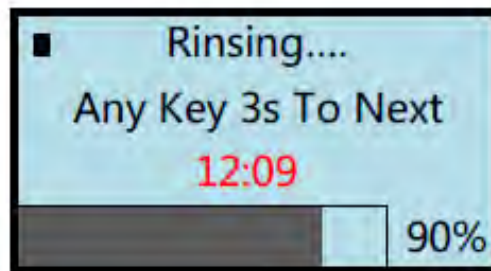
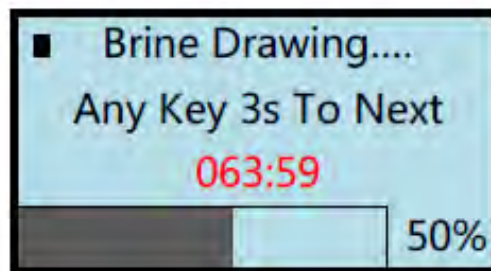
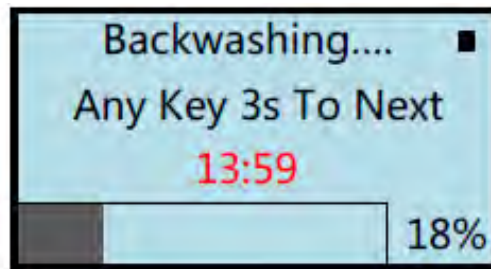

- The regeneration can be manually advanced by holding any button for three seconds.

Screen Display During Regeneration

Section 8.3

Filter display during regeneration

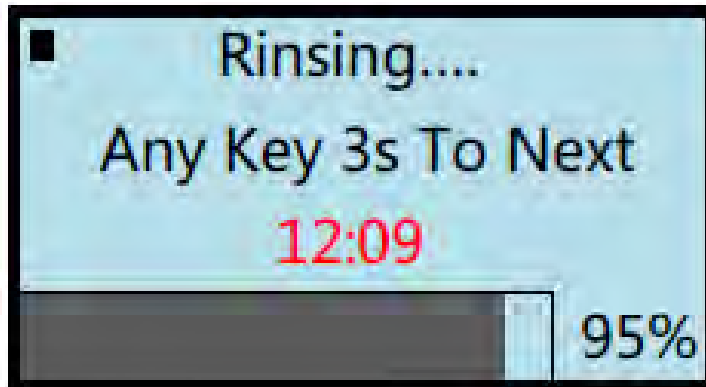
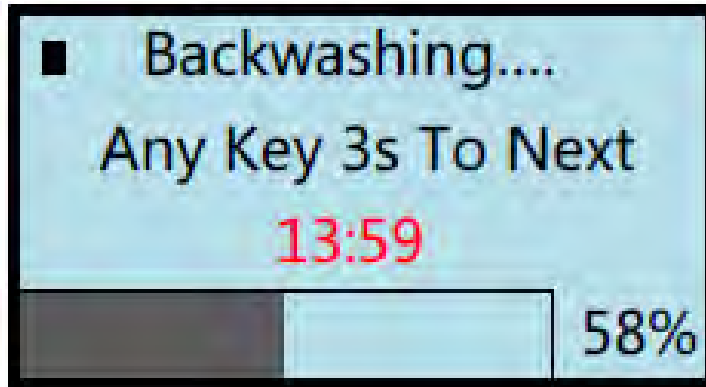

- The regeneration can be manually advanced by holding any button for three seconds

Main Menu Setup And Programming

Section 8.4

- To access the programming screens, do the following:

- Push MENU to advance to the user menu screen and use the ARROWS to highlight Main Menu.

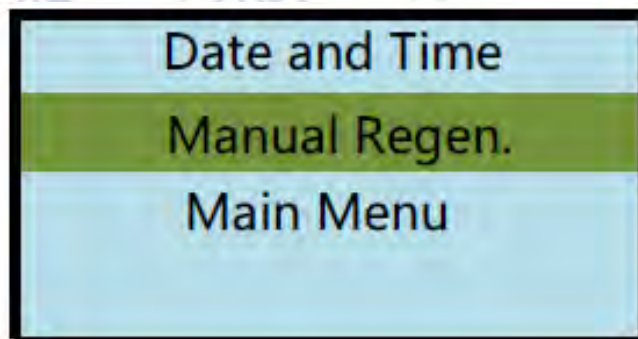
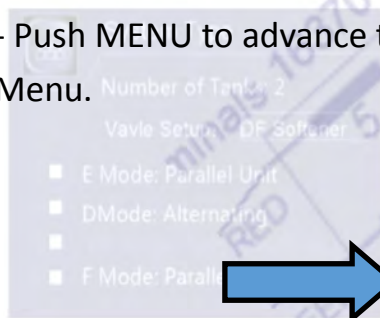

- Push and HOLD the SET button for 5 seconds until the controller beeps.

Main Menu Setup And Programming

Section 8.4

- The Main Menu screen that appears will change with how the valve is programmed

Days

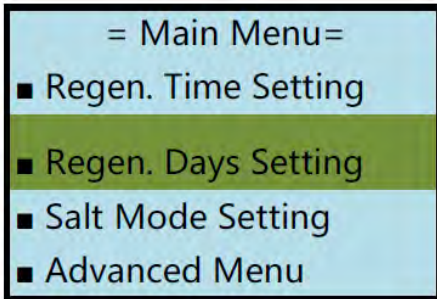

Calendar

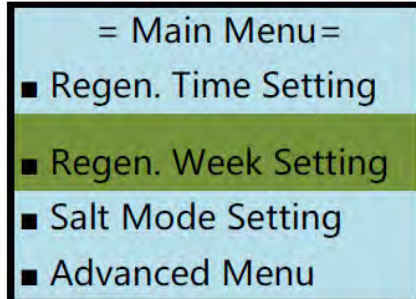

Meter Delayed

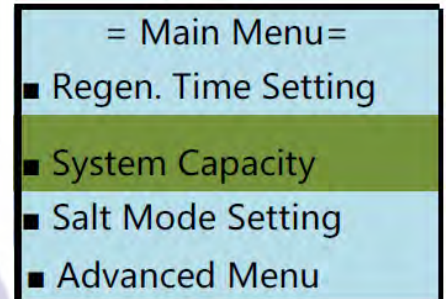

Meter Immediate

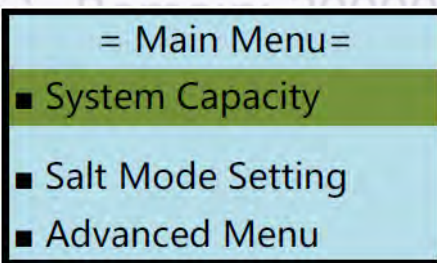

Days / Meter Over Ride

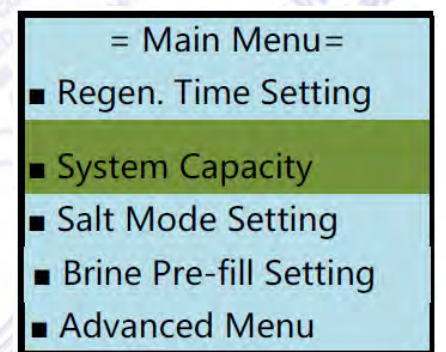
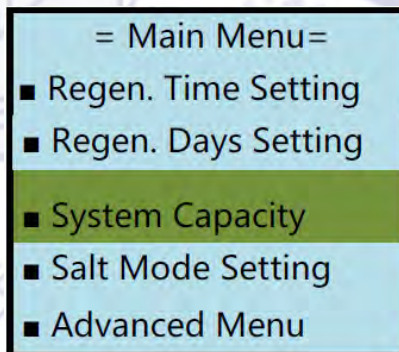

- Default factory settings.
- Regeneration time : default 2:00 AM.
- Regeneration day of the week: default ON Saturday.
- Regeneration day interval: default 7 days.
- Capacity: default 20000 gallons.
- Proportional brining: default off, If ON range is 50% - 90%.

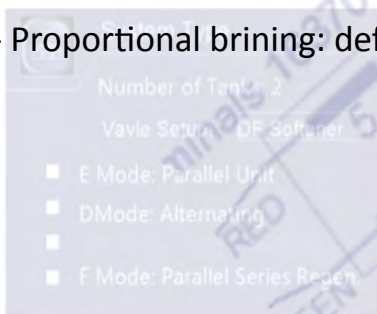

Main Menu Setup And Programming

Section 8.4

- The Main Menu screen that appears will change with how the valve is programmed

Days

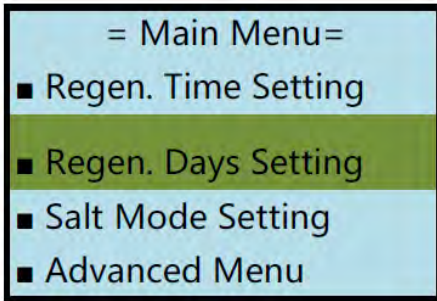

Calendar

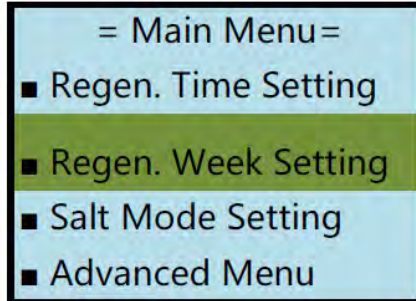

Meter Delayed

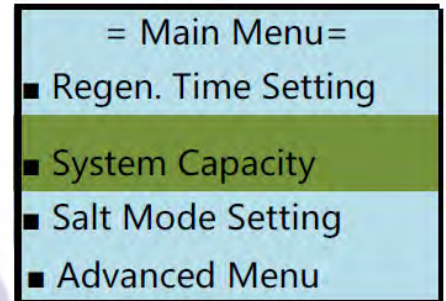

Meter Immediate

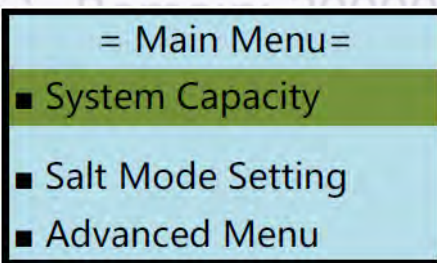

Days / Meter Over Ride

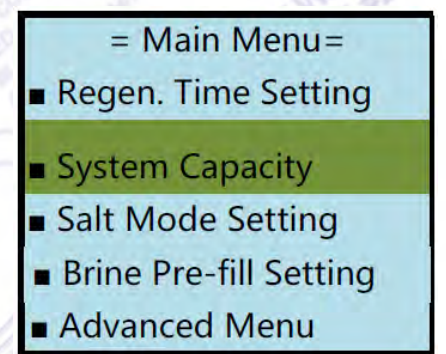
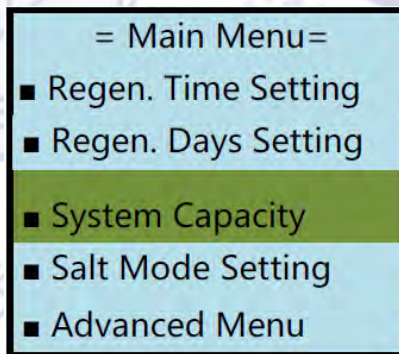

- All Default value below is from factory writing on PCB. 1)

- Regen. Time Setting: default 2:00 (2:00AM)

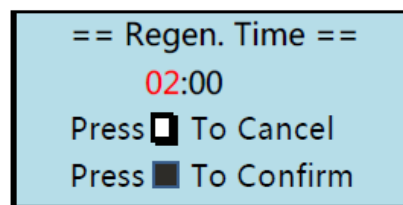

- Regen. Week : "□" means turn OFF , "√" means turn ON for said weekday. Below "M、 T ~ Sun" , assign to Monday/ Tuesday... Sunday, default: "ON" on Saturday.

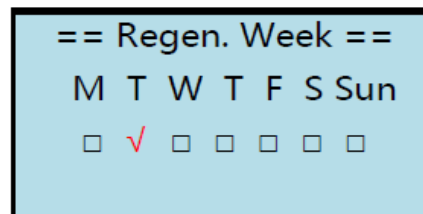

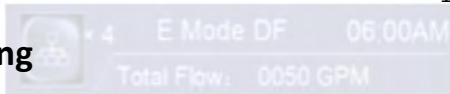

- Regen. Days : interval days between regeneration, default 7 days.

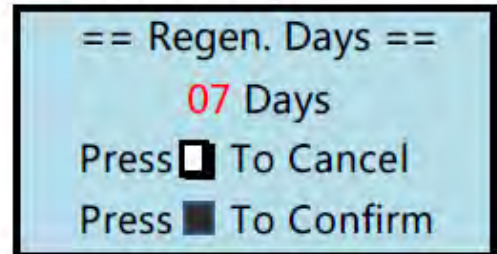

- Capacity setup: default value 20000 gallons

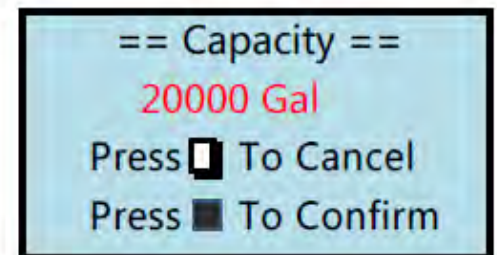

- Proportional brine function setup:

default turn OFF , percentage range: 50%-90% (if turn ON)

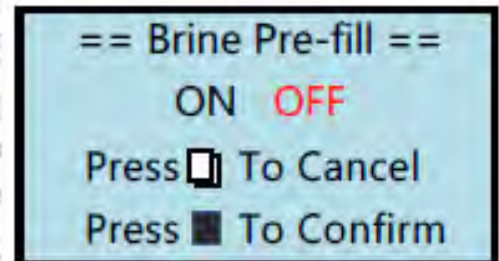
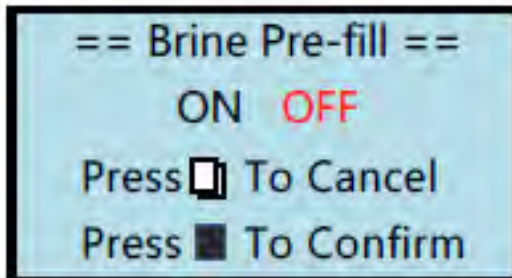

- Advanced Menu setup :

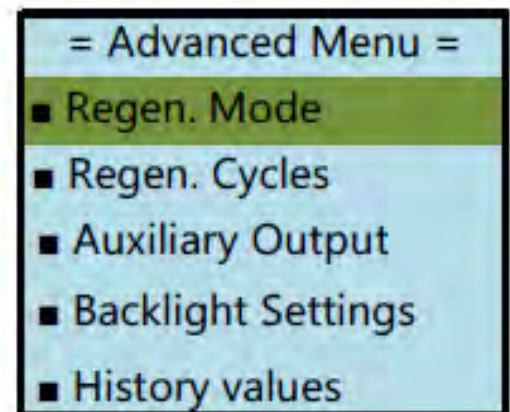

Main Menu Setup And Programming

Section 8.4

- Regeneration initiation mode : Default Meter Delay MD

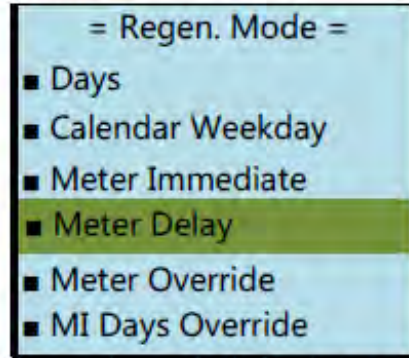

- Further reserve settings will be done if MD or MO was selected, default is Weekly Maximum:

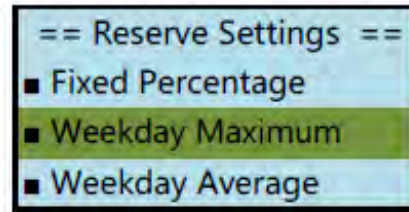

- For fixed percentage, adjustment range : 0~50% :

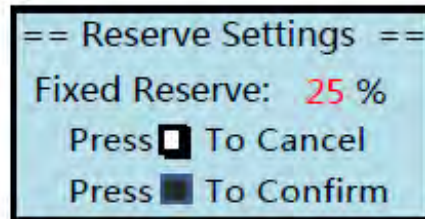

-Regen. Cycles duration settings:

Down Flow

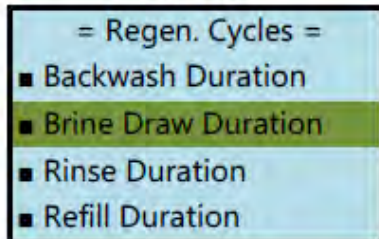

Filter

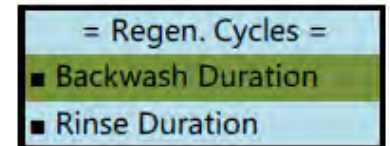

- All are same as Backwash duration setting display:

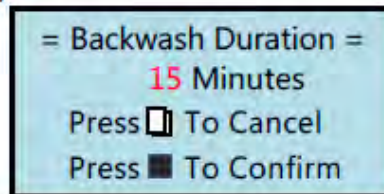

-Default: BW 15 mins, Brine draw 90 mins, Rinse 15 mins, Refill 10 mins.

Main Menu Setup And Programming

Section 8.4

- Auxiliary outputs settings :

1# and 2# output settings individually and same procedure

Output signal : 12VDC, <200mA current

Status symbol on the screen: 1# display at top left and 2# display at top right

"■"- Set On , Blank- Set Off

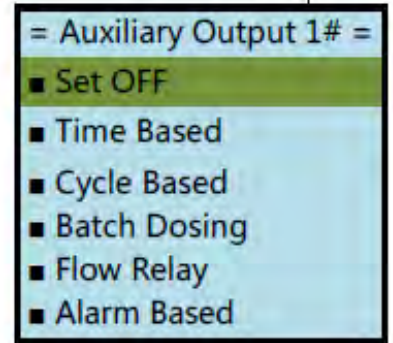
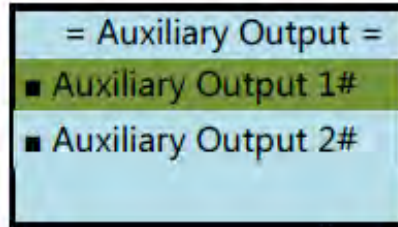

- Time based: default as 0 Mins.

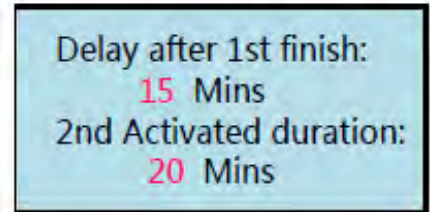
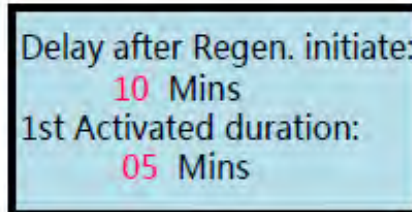

- Cycle based: Output contacts closed upon the cycles activation. Active cycles are ticked off.

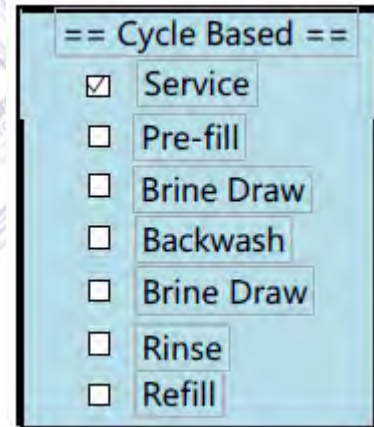
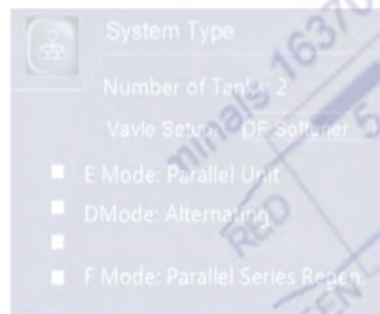

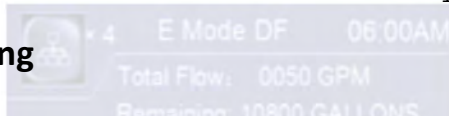

- Batch dosing: default value is 1000Gallons (1~9999) 10.0Mins (0.1~99.9)

= Batch Dosing =
 100 Gal 10.0 Mins
 Press To Cancel
 Press To Confirm

- Flow switch relay: default flow rate 10 gpm (1~99)

=== Flow Relay ===
 Set point: 1 0 G P M
 Press To Cancel
 Press To Confirm

- Back light settings: default "Energy Save", back light is on for 1 minute.

= Backlight Settings =
 Energy Save
 Always On

System Type
 Number of Tanks: 2
 Valve Setup: DF Softener
 E Mode: Parallel Unit
 DMode: Alternating
 F Mode: Parallel Series Regen

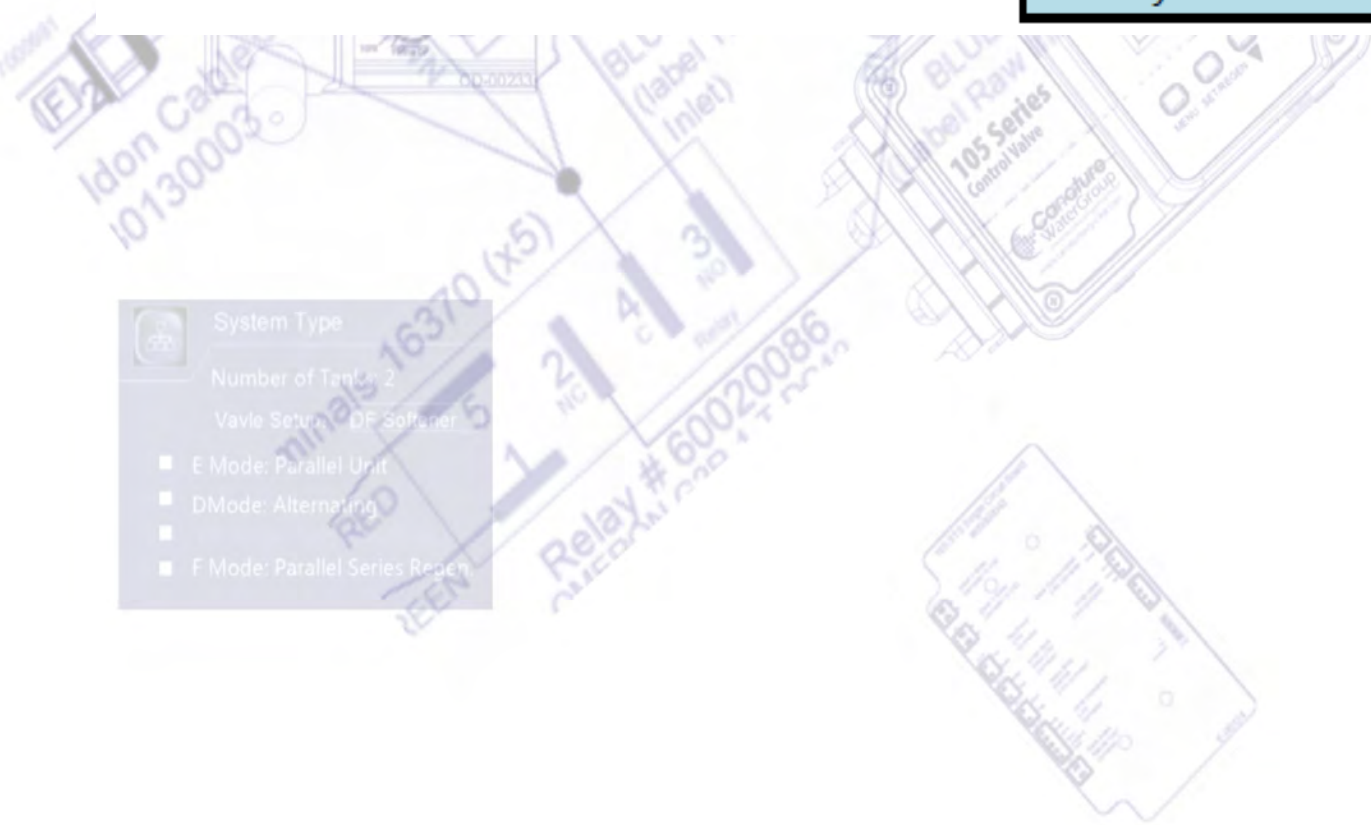

-The menu path to History Values is :

Main Service Screen > Main Menu > Advanced Menu > History Values

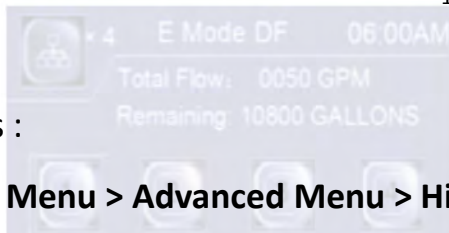

- = History Values =
- General Diagnostics
- Reserve
- Usage History

Flow Rate:
17-Feb-2018

System "General Diagnostics" display:

Last Regen. On:
17-Feb-2018 , 02:00
Used Since Regen.
02341 Gallons

Peak Flow Rate on :
17Feb-2018 12:25
Days to Regen.:
00

Current Flow Rate:
029 GPM
Peak Flow Rate
059 GPM

Software Version:
105MUSG-1.00

Reserve of each weekday display as:

Monday: 1351Gal
Tuesday: 1412 Gal
Wednesday: 1320 Gal
Thursday: 1225 Gal

Friday: 1625 Gal
Saturday: 3320 Gal
Sunday: 420 Gal

**Programming
Diagnostics And History**

Section 8.5

- OR a fixed reserve value as:

Fixed Reserve :
Percentage: 25%
Volume: 2680 Gal

- Usage History:

Flow Rate: 20 GPM
17-Feb-2018 10:25
Remain: 20000 Gal
Capacity: 20000 Gal

== Usage History ==
■ 56 Days History
■ History Since Startup
■ History Since Reset

- Past 56 days water usage records:

== 56 Days History ==
Sun Dec 01: 2325 Gal
Mon Dec 02: 1325 Gal

Sat Jan 25: 2641 Gal

- All history data can be reset:

= 56 Days Reset =
NO YES
Press To Cancel
Press To Confirm

= 56 Days Reset =
Reset confirm?
Press To Cancel
Press To Confirm

⇒

⇒

- History information since start-up:

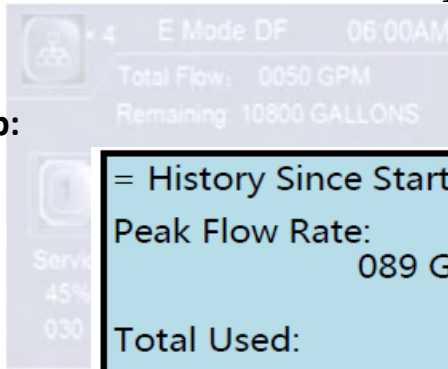

= History Since Startup =
Peak Flow Rate: 089 GPM
Total Used: 123456789 Gallons
Total Regen: 0088
Total Days: 0325

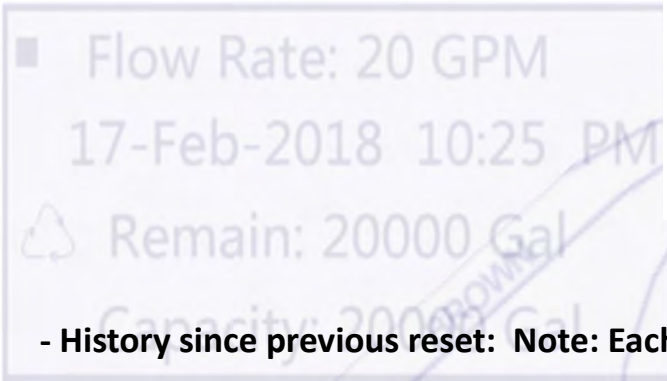

- History since previous reset: Note: Each record could be reset if entered and confirmed.

= History Since Reset =
Peak Flow Rate: 089 GPM
Total Used: 123456325 Gallons
Untreated water: 123456799 Gallons
Total Regens: 0088
Total Days: 0325

= History Since Reset =
Reset confirm?
Press To Cancel
Press To Confirm

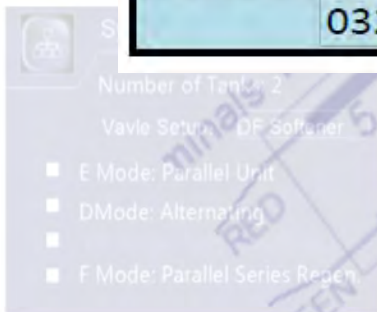

Programming
Alarm and Errors

- Issue: Controller plugged on power, the buzzer beeps and the screen displayed “System Error E1”

Cause: The wire of micro switch is not plugged or loose

Solution: Check the micro switch and connect the wire well

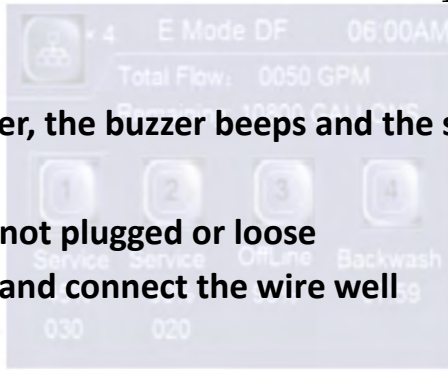

- Issue: The buzzer beeps and the screen displayed “ System Error E2”

Cause: The motor can't find its right position in 10 mins, micro switch or motor malfunction, automatic circuit protection action.

Solution: Check the connection of micro switch and motor, piston and drive mechanism.

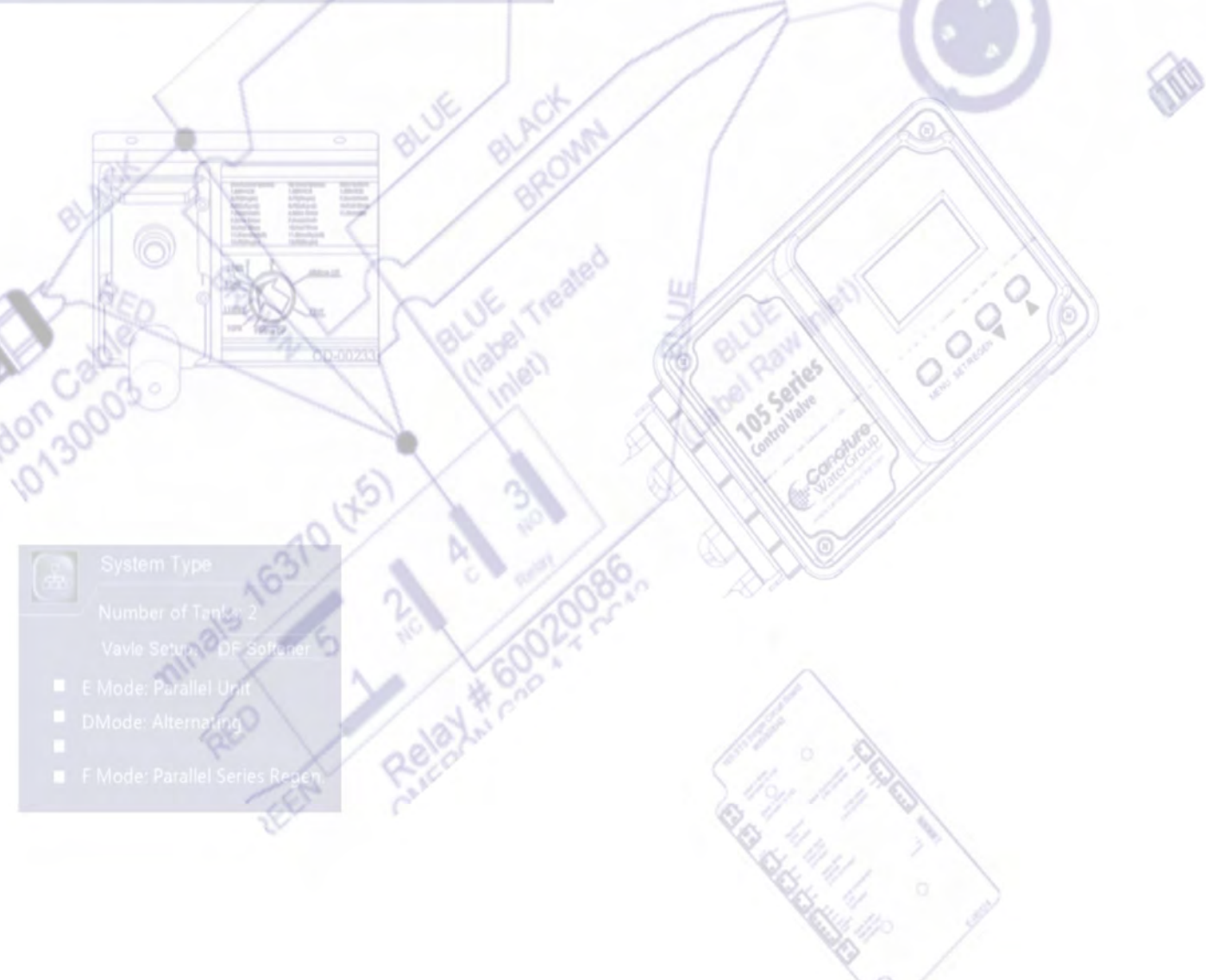
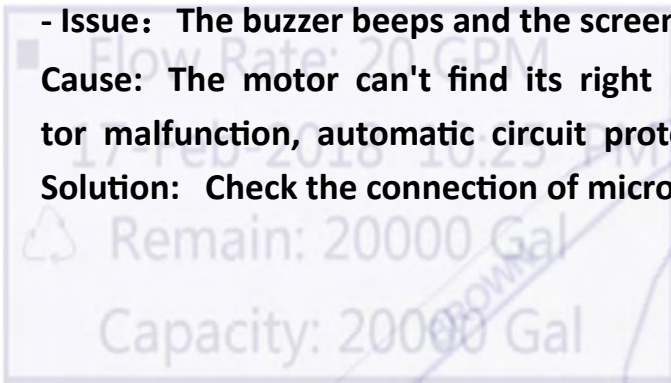

System Type
Number of Tanks: 2
Valve Setup: DF Softener
■ E Mode: Parallel Unit
■ DMode: Alternating
■ F Mode: Parallel Series Regen

General Maintenance

Section 9.0

Caution: To prevent personal injury, or damage to the system, properly relieve the system pressure before doing any servicing on the control valve, piping or on the media tank.

1. Turn off the water supply on both the inlet and the outlet piping to the control valve / unit.
2. Step the control valve through a complete regeneration cycle once to relieve the pressure inside. To do this push and hold the “SET/REGEN” button on the valve keypad. Once the valve moves into regeneration, the valve can be advanced through the regeneration cycles one at a time by pushing, (& briefly holding), the up or down arrow button. Make sure the valve is back in the service position when done.
3. Once the control valve is back to the service position, unplug the electrical power to the unit.
4. For any individual part identification, see section 10.

General Tools Recommended

Tools recommended to perform basic service on the 105 control valve are:

- Seal stuffer & puller, (70020033).
- Silicone grease, (1014081-8 oz tube).
- Anti seize compound (for Stainless to stainless bolt connections).
- 8 mm nut driver or socket with ratchet.
- 6 mm, 4 mm & 2.5 mm Allen wrenches.
- #2 Phillips screw driver.
- 2.4 mm (0.1”) wide flat screw driver.
- Large flat screw driver.
- Needle nose, channel lock & snap ring pliers.
- Wire hook or dental pick hook, (at least 12” long).
- Chain or strap wrench.
- If changing media, a wide mouth funnel #99004 and a media extractor kit #50040050 are recommended.



#99004

#50040050
105 Control ValveCanature
WaterGroup

PCB / Drive Motor / Power Head Removal

Section 9.1

Caution: To prevent personal injury, or damage to the system, properly relieve the system pressure before doing any servicing on the control valve, piping or on the media tank.

- Turn off the water supply to valve and relieve the pressure inside as explained in section 9.0.1 & 9.0.2
- Unplug the electrical power, remove the wire cover screws and remove cover attached with 4 Philips screws.
- Please note that to remove or replace the PCB (circuit board), drive motor, or powerhead, the wires connecting to the micro switches are not required to be removed.

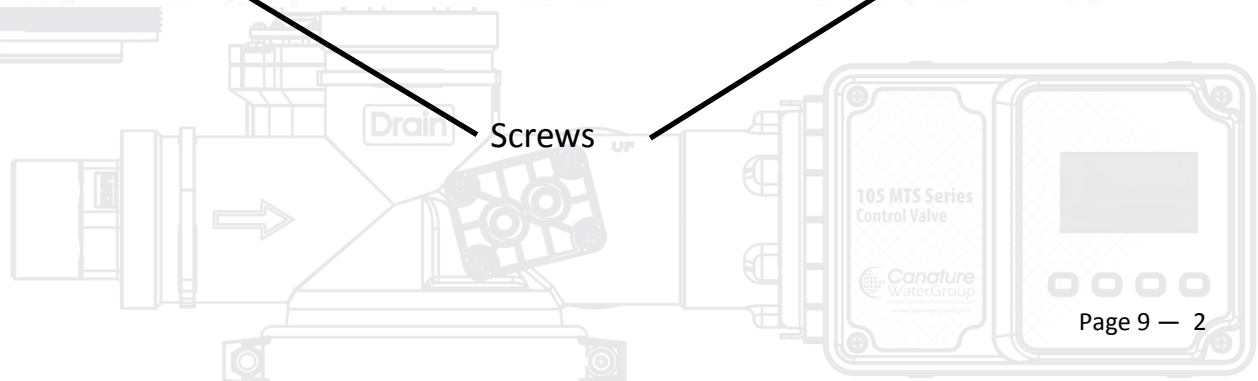
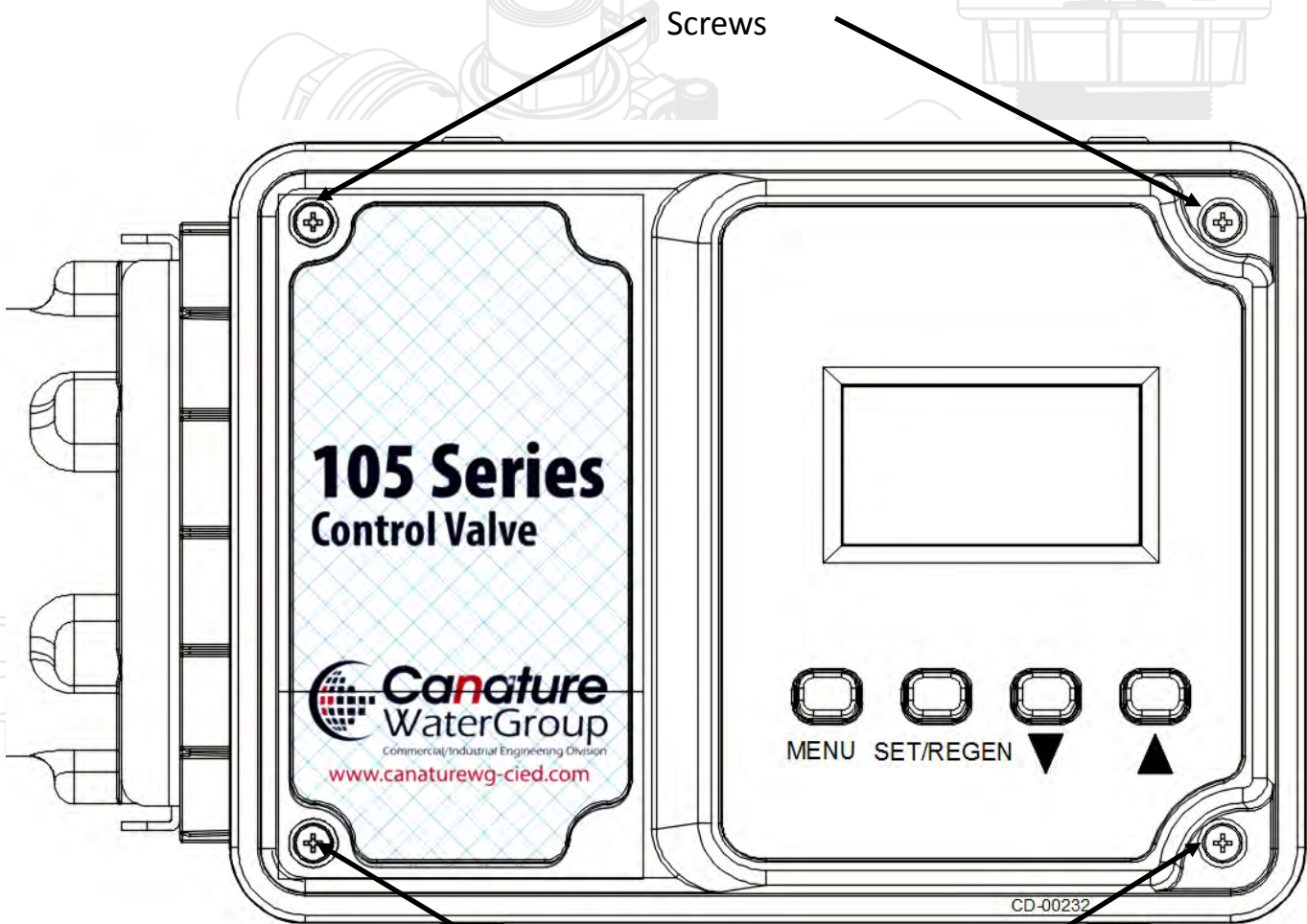

PCB / Drive Motor / Power Head Removal

Section 9.1

- Disconnect all internal wire plugs from the PCB circuit board back. Note the location of each (they are color coded). Be careful not to pull the wires out of their terminals. Use needle nose pliers or flat screw driver if necessary. Use the 2.4 mm flat screw driver to release any wires that are to the screw terminals. Remove the cover with the PCB.
- If replacing the PCB (circuit board), remove the four screws holding the board to the cover and replace the board. Reconnect the wires and replace the cover. Plug the system back in.
- Reprogram the system. Once the programming has been completed, step the valve through a complete regeneration cycle to ensure everything is operating as intended.

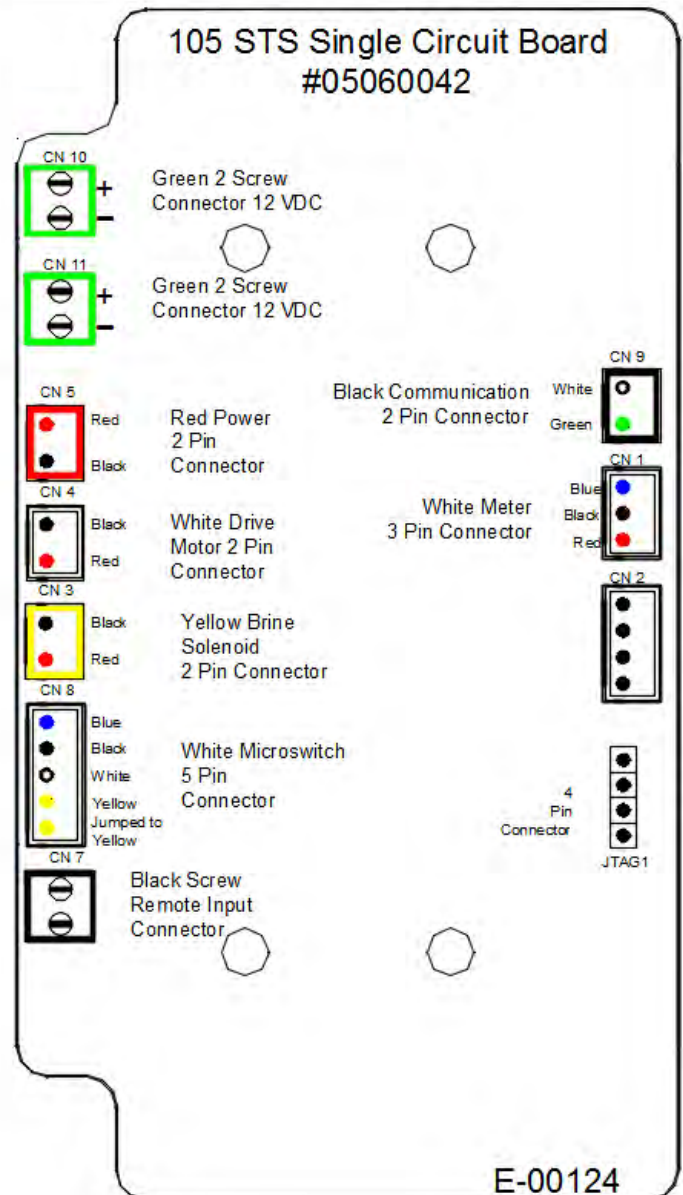
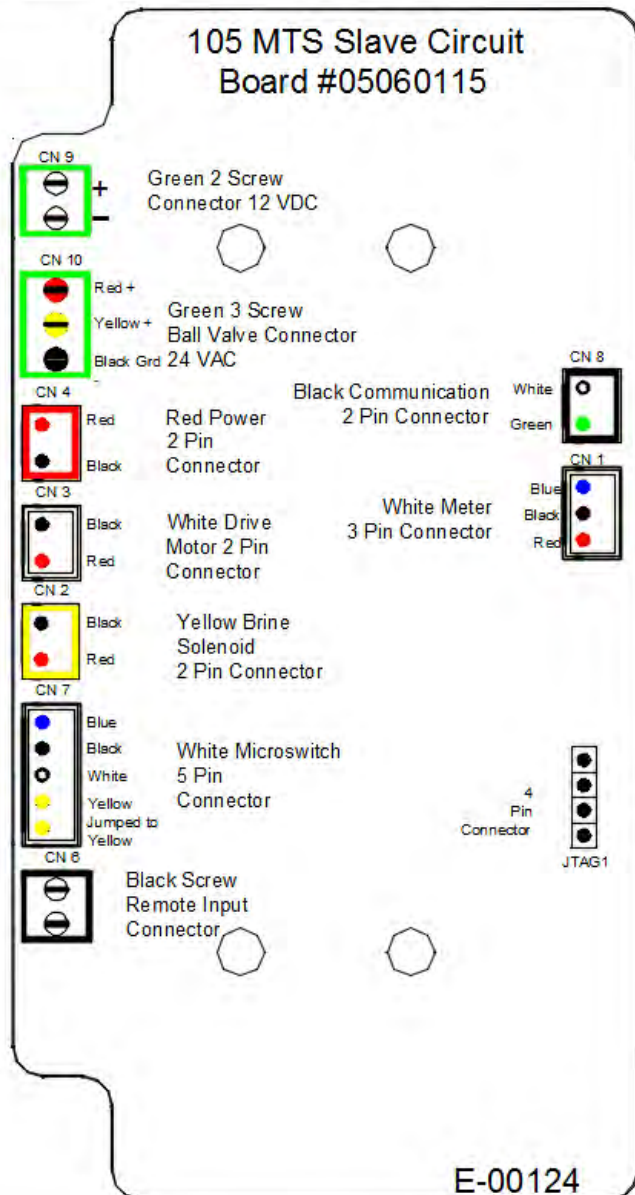
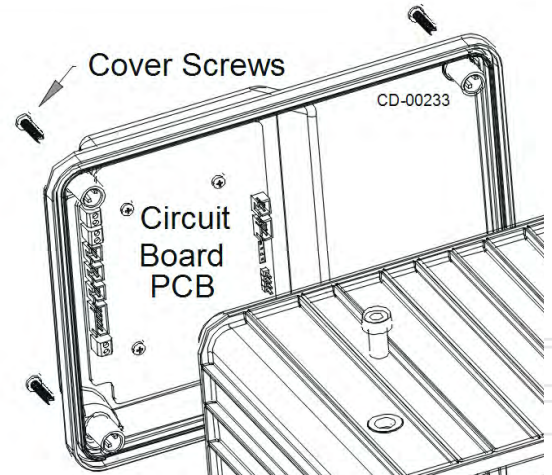

PCB / Drive Motor / Power Head Removal

Section 9.1

- Remove the four motor 6 mm Allen bracket bolts (05060065), using the 6 mm Allen wrench. There are two bolts on the top & two on the bottom of the plastic power head bracket (05060037). Carefully remove the motor assembly from the plastic power head bracket. **NOTE: Do not hold the motor assembly by the wire motor frame (05060074), as the wire frame is only pushed into the motor and can slip out.** Also note that the micro-switch wiring and motor wiring will come out with the motor assembly.

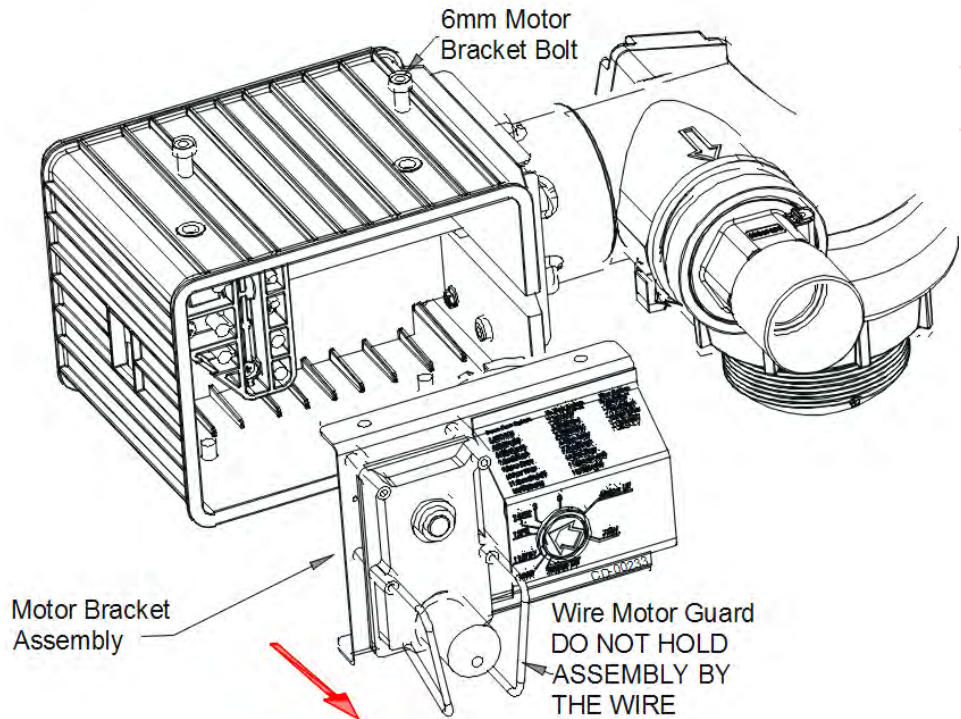

- Attached to the back of the motor bracket assembly is the drive cam, (05060109). Ensure the slot follower (05060023), is also removed. It rides on a shaft on the gear and it is easy to miss. When reinstalling the slot follower, be sure to silicone grease both the shaft it rides on as well as the slot it travels in.

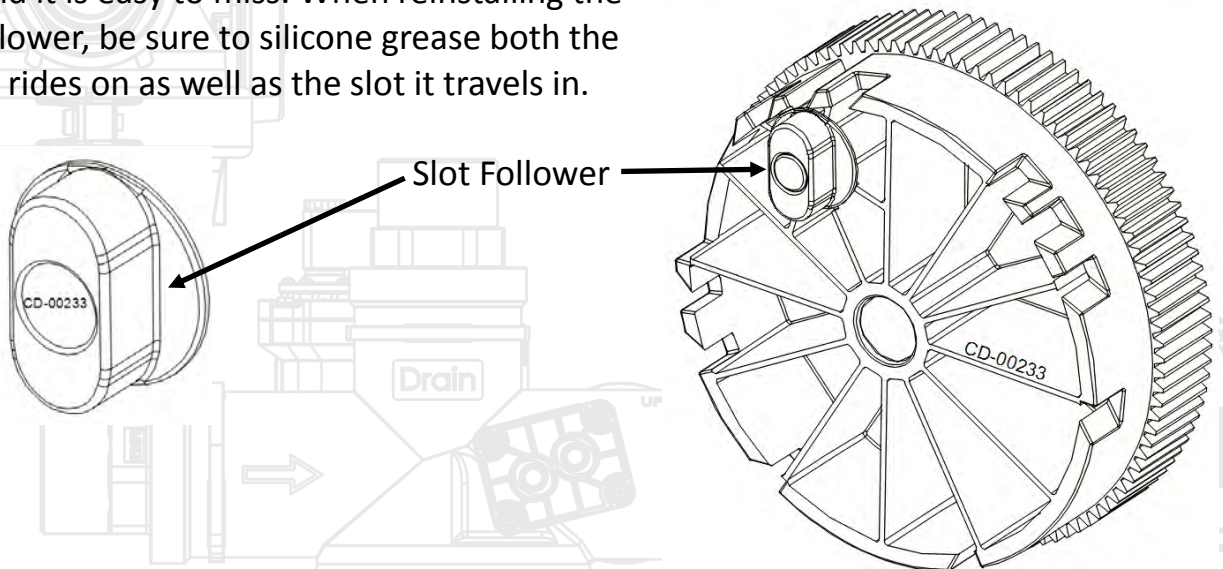

PCB / Drive Motor / Power Head Removal

Section 9.1

- To remove the large gear (05060109), loosen the bottom micro-switch screw and remove the top micro-switch screw. This will allow the micro-switches to be rotated slightly to allow the large gear to be separated from the motor assembly. The micro-switch wires do not have to be removed. When reassembling the large gear into the motor assembly be sure to depress the anti reverse pawl (05060035).

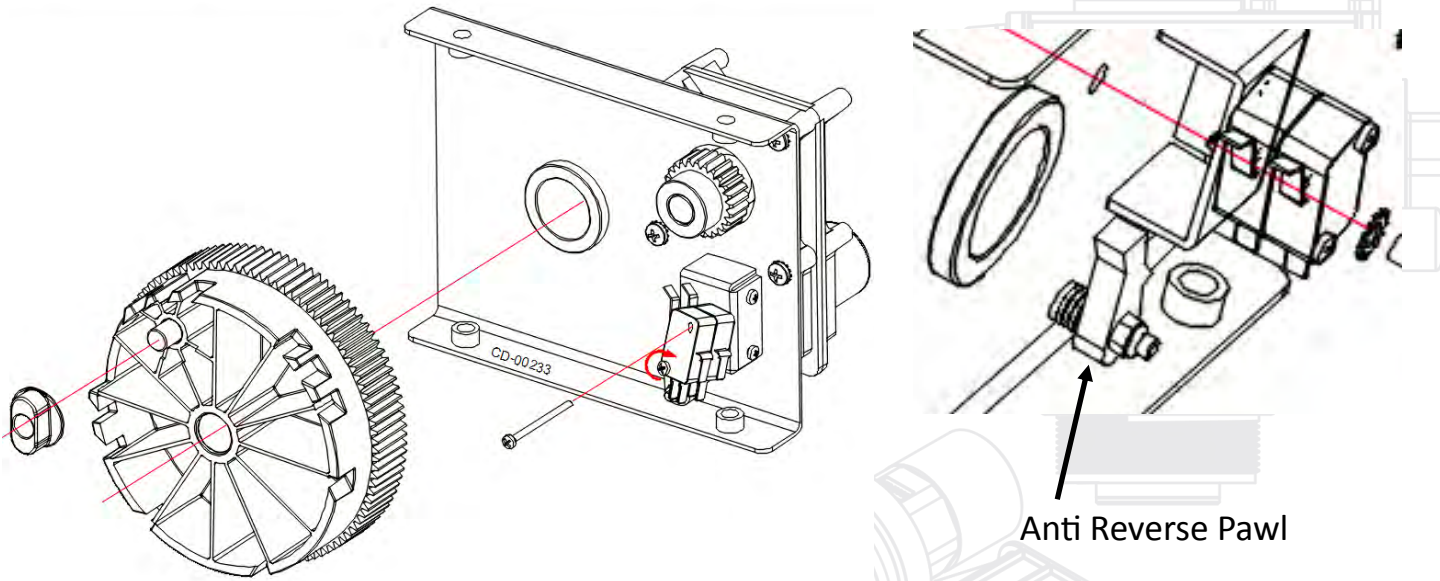

- Once the drive motor assembly has been separated from the power head bracket, the drive motor can then be removed from the assembly by unscrewing the four head screws. The motor drive gear can be removed from the motor “D” shaped shaft by loosening the 2.5 mm Allen head set screw. To reinstall motor assembly, see section 9.2.

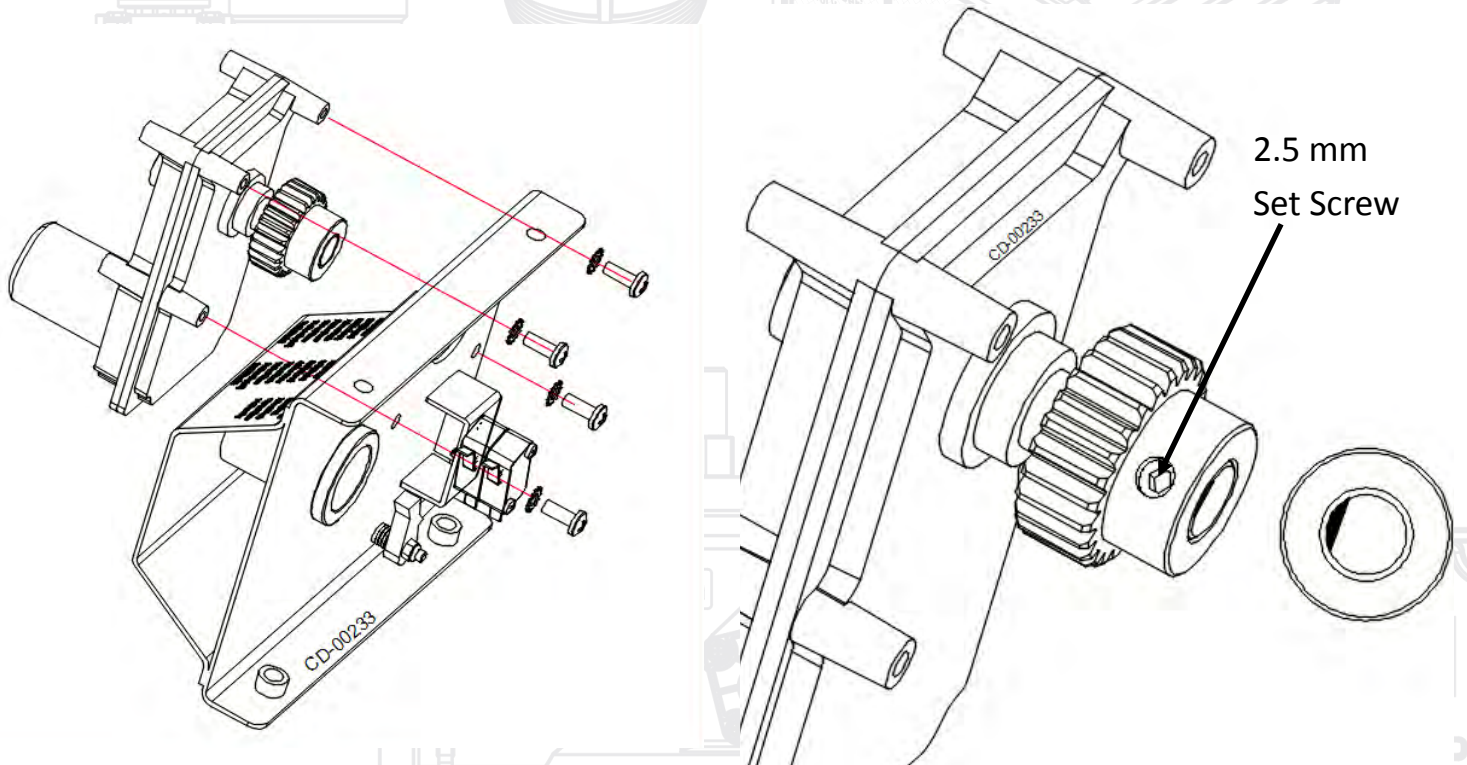

PCB / Drive Motor / Power Head Removal

Section 9.1

- There are six Allen head bolts holding the plastic power head bracket, (05060037). Remove the two smaller 4 mm Allen bolts (05056086B), using the 4 mm Allen wrench. Then remove the four 6 mm bolts (05060066). Please note that these 6 mm bolts are longer than the bolts previously removed. The plastic powerhead bracket can now be removed by moving the bracket to the left as illustrated below.

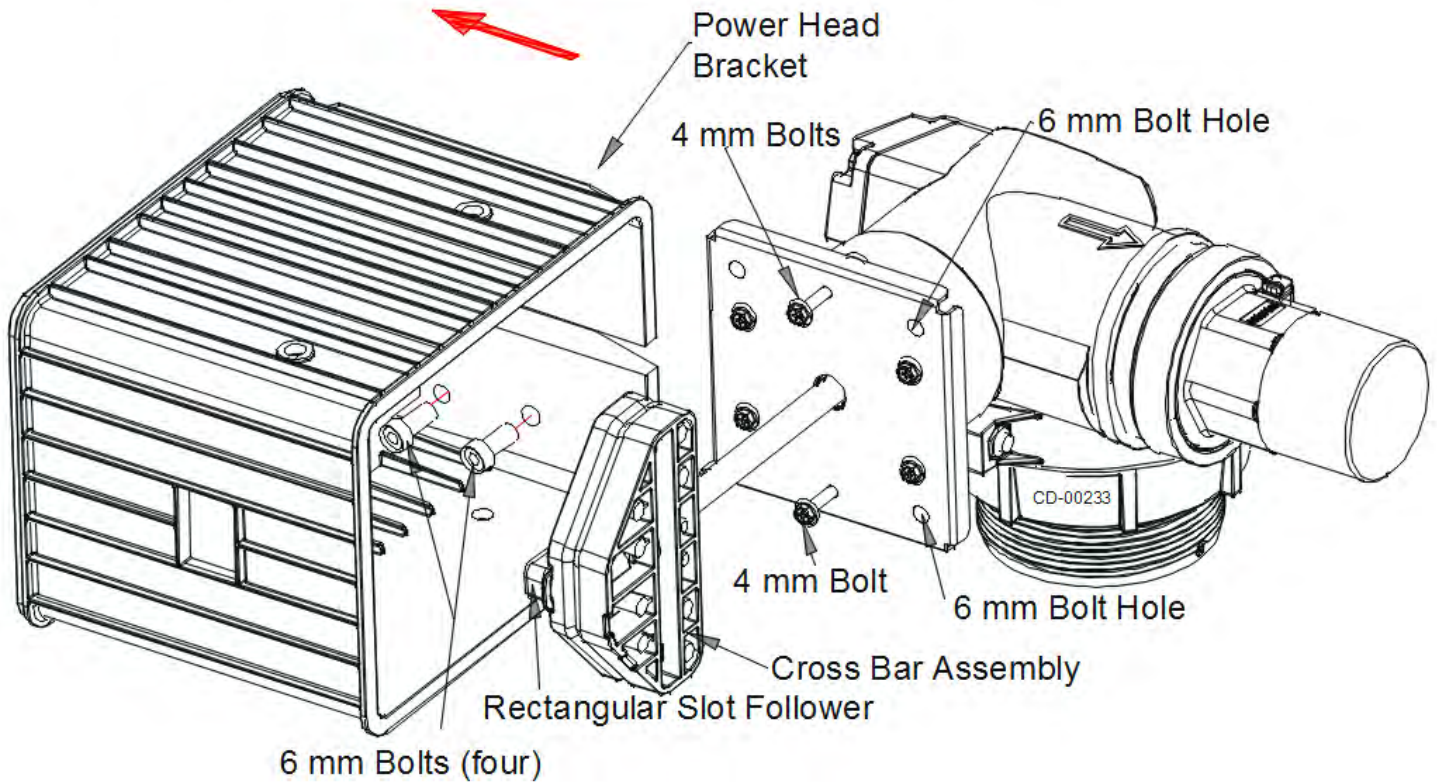

- Attached to the back of the cross bar assembly is the rectangular slot follower, (05060024). Ensure the rectangular slot follower is also removed. When reinstalling the slot follower, be sure to silicone grease the slot in the plastic powerhead bracket that it travels in.
- For assembly procedures, see section 9.2.

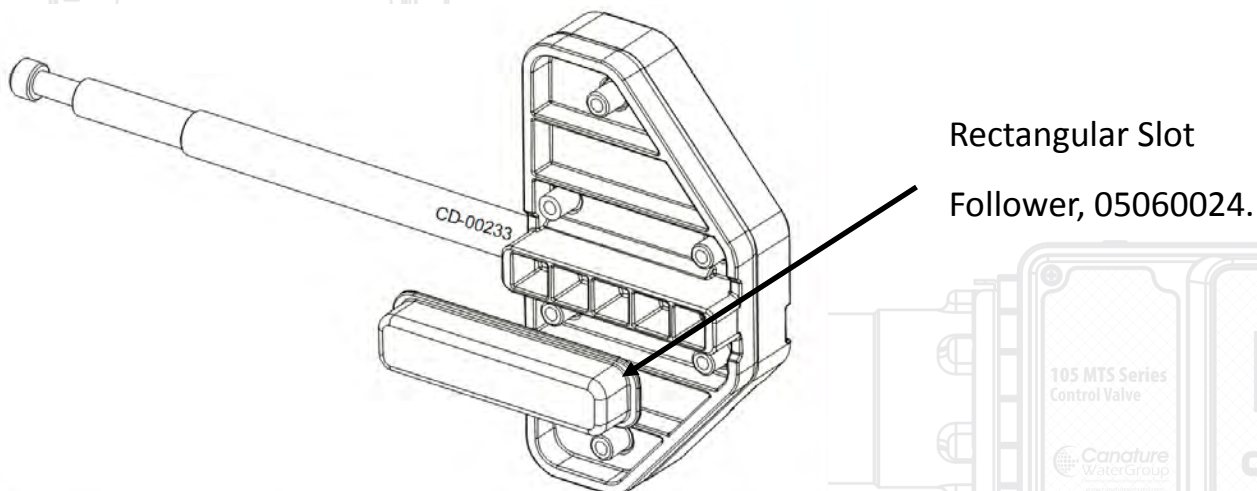

Rectangular Slot Follower, 05060024.

Piston / Seal / Spacer (Lantern Ring) Replacement

Section 9.2

- To replace the piston and / or the seals and spacers, first remove the powerhead. See section 9.1.
- Remove the four, 8 mm bolts holding the stainless steel end plate in place. (8 mm socket / nut driver or Philips screw driver).

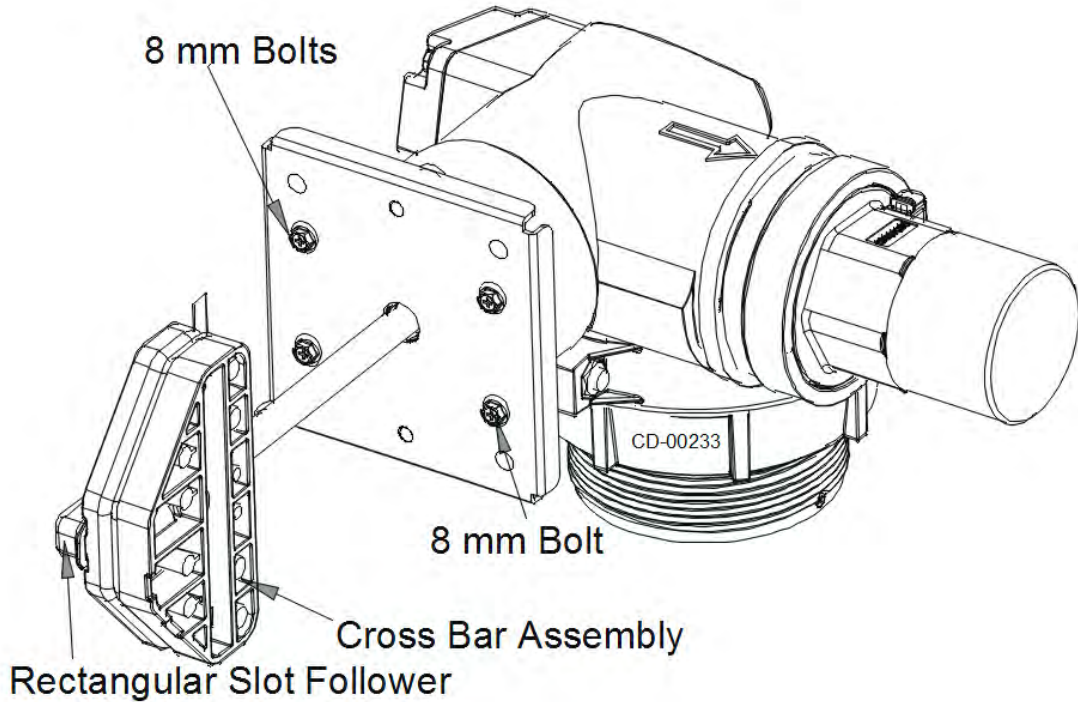

- **NOTE:** Some times pushing the piston assembly slightly in, and then pulling makes it a easier to slide the assembly out.

Grasp the crossbar assembly and slowly pull the end plug and piston assembly out of the valve body and set aside. Be careful to pull the piston assembly straight out. If that is not properly done, the piston rod and / or piston could be damaged.

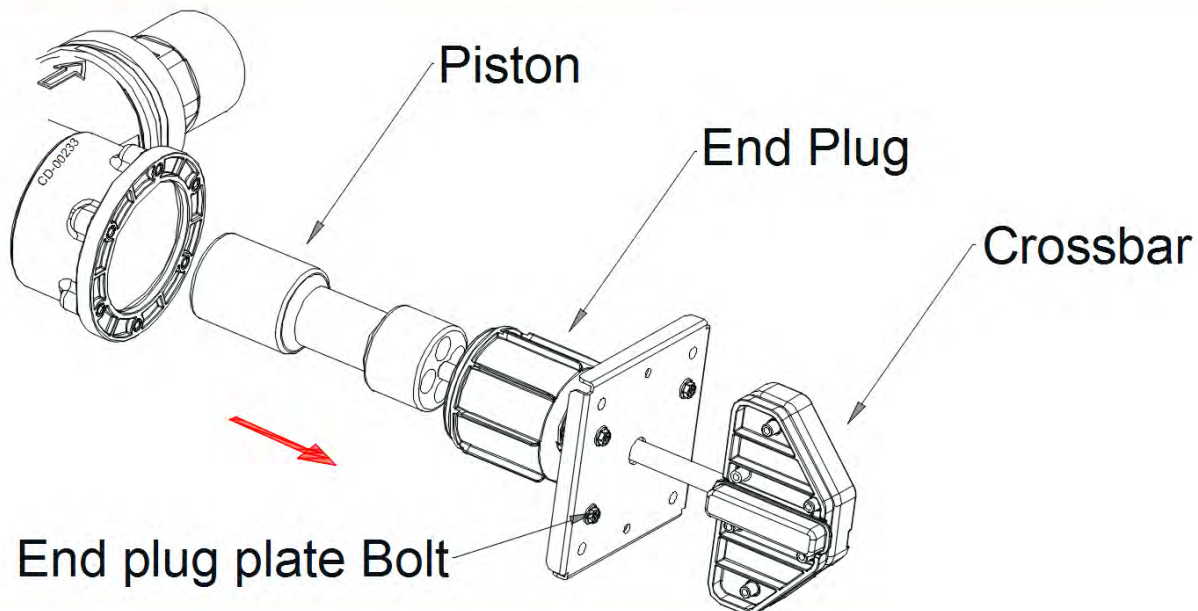

Piston / Seal / Spacer (Lantern Ring) Replacement

Section 9.2

- Pull out the tool together with the seals and spacer. Remove the spacer from the tool end by pushing button back with the pins retracted. A wire hook can be used to take the outer O-ring out from the valve body if it drop off during disassembly. On the diagram below, the proper sequence is shown for the seal /spacer / o-ring assembly with the colors listed. The diagram starting at the left side is the back of the valve, going to the right is the front of the valve. Note: If the no raw water piston PLUG option is used, the first seal is left out. If the no raw water bypass trailer piston is used, all seals are used. See section 10 for more details.

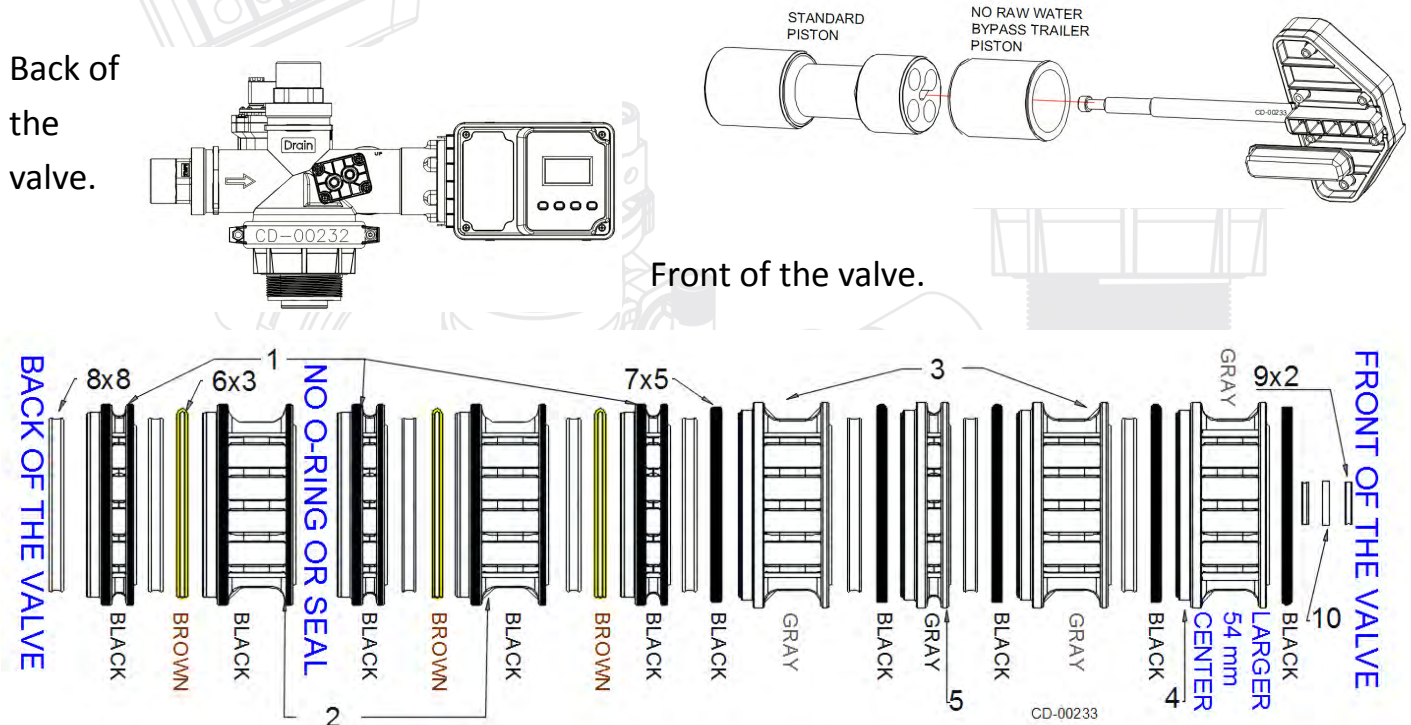

Item	Part Number	Description	Quantity
	05060134M	Complete Kit (Individual parts shown below)	
1	05060005	Lantern Ring I Black 50 mm	3
2	05060006	Lantern Ring II Black 50 mm	2
3	05060007	Lantern Ring III Gray 50 mm	2
4	05060098	Lantern Ring V Gray 54mm	1
5	05060008	Lantern Ring IV Gray 50 mm	1
6	05060056	O-Ring 59.92x3.53 Brown	3
7	05060057	O-Ring 63.09x3.53 Black	5
8	05060049	Quad Ring 50.17x5.33 Black	8
9	05060050	Quad Ring 12.37x2.62 Black	2
10	05060115	Quad Ring Gasket	1

Piston / Seal / Spacer (Lantern Ring) Replacement

Section 9.2

- A special tool (PN. 70020033) should be used to remove and install seals & spacers. The tool has four retractable pins. The pins are retracted or extended out by pulling or pushing the center button on the opposite end. This tool works on all the spacers except the first spacer which is usually pulled out by hand. The reason for this is the first spacer, (05060098), has a slightly larger center hole, (54 mm in diameter compared to 50 mm for all other spacers). It is **critical**, that this spacer is placed in the proper position when reassembling. It is important to note the order the seals , spacer and o-rings are removed as they must be installed in the correct order. They are not all the same.



- Insert the tool (PN. 70020033) into the valve body with the pins retracted, (center button pulled back). Push the tool tight against the spacer and push the button in. When the button is pushed in, pins are pushed out to engage the holes in the spacer. The tool may have to be rotated slightly to allow the pins to extend into the slots of the spacers.

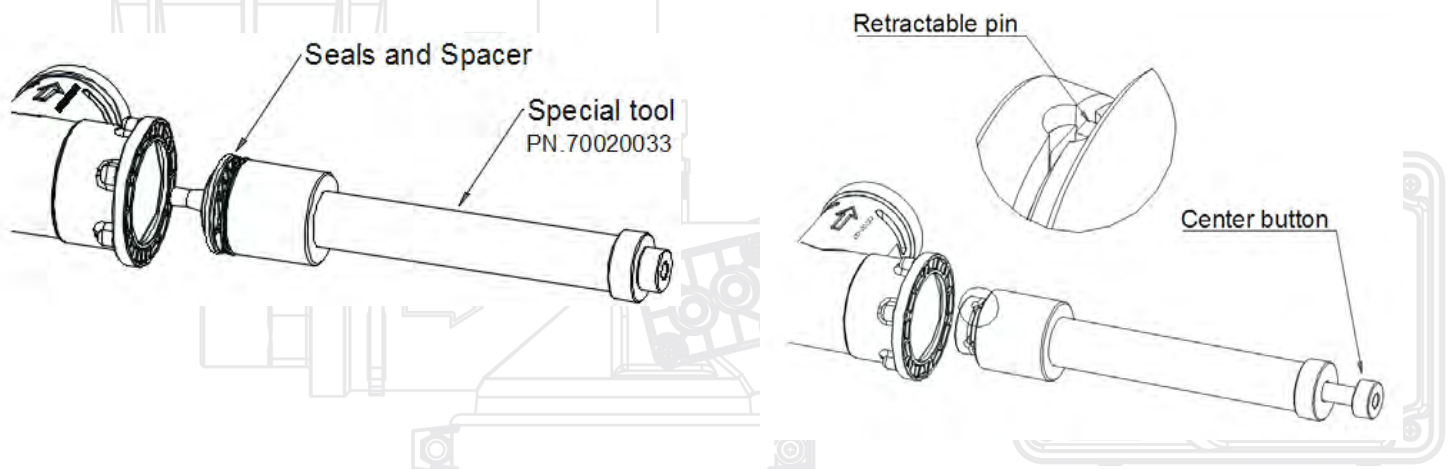

Piston / Seal / Spacer (Lantern Ring)

Section 9.2

-Do a visual check through the center of the valve and ensure all the seals, spacer and O-rings are in place and fully inserted into the valve body.

- Reassemble the piston assembly keeping the piston rod slot pointing up to prevent the piston from sliding off the piston rod. Ensure the proper piston assembly is being used. The basic piston stays the same but a trailer piston or piston end plug can be used for no raw water bypass (see section 10.3.0).

- Apply silicone grease on to the piston, (and trailer piston if required) as well as the piston rod. Hold the cross bar assembly and the piston / end plug and carefully guide the assembly straight into the valve body.

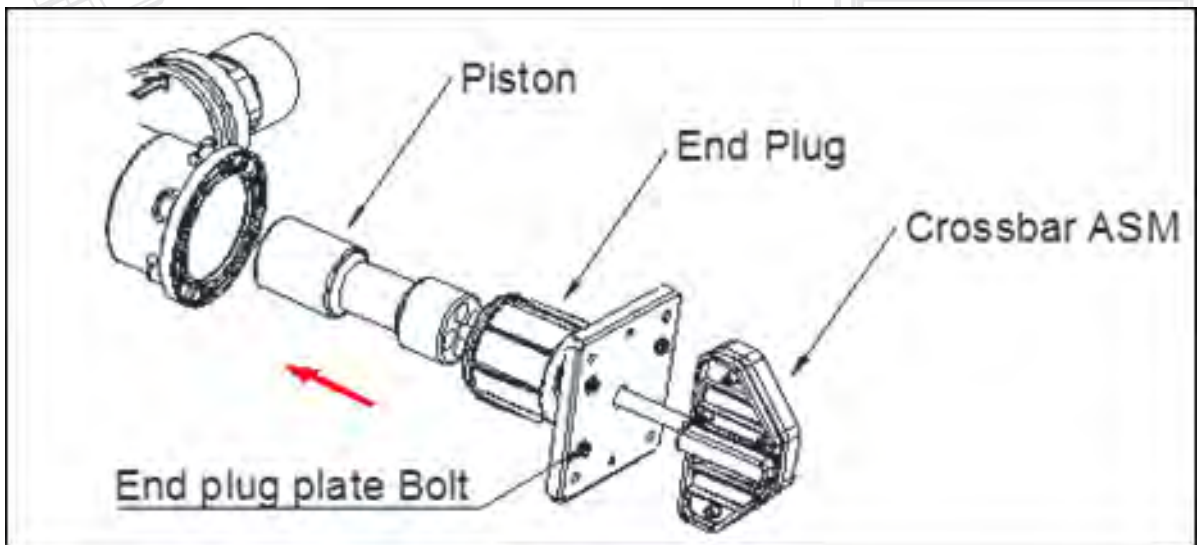

- The end plug will protrude approximately 1/8" to 1/4" out of the valve body until the end plate is attached. Use the four 8 mm bolts to attach the end plate .

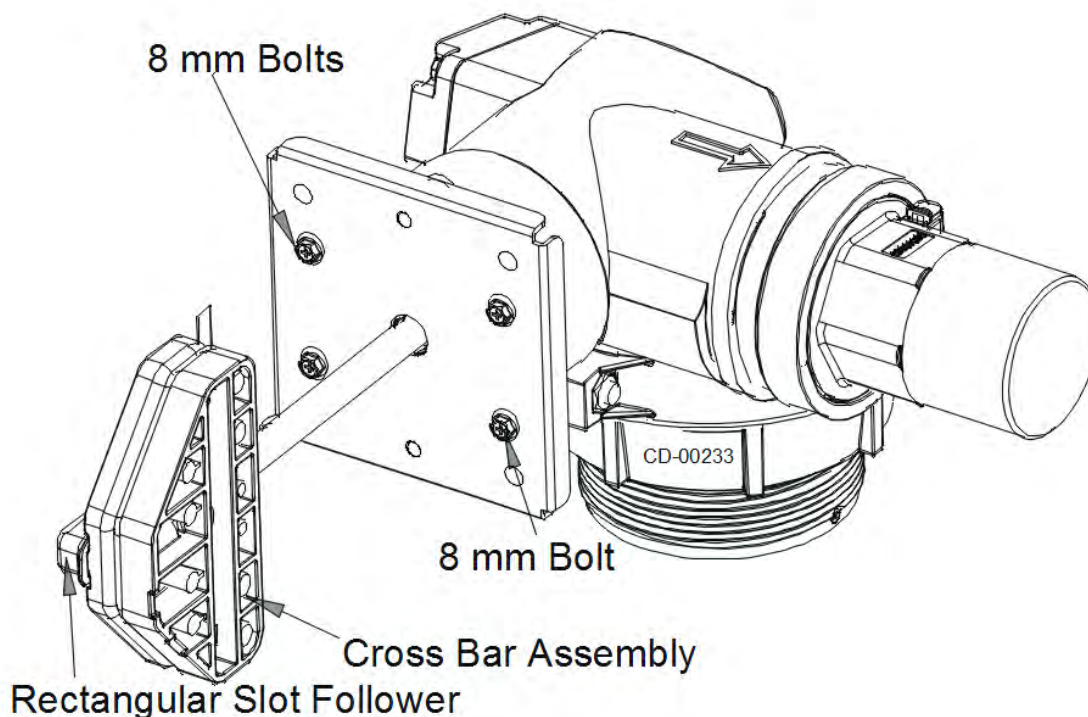

Piston / Seal / Spacer (Lantern Ring) Replacement

Section 9.2

-Confirm the piston assembly moves freely with one hand while holding the plate fixed on the valve body.

-The outer plastic bracket can now be reinstalled. **NOTE: INSTALL POWER HEAD BRACKET AS SHOW BELOW. The bolts do line up if reversed but the valve will not function as intended.** Lightly apply silicone grease into the cross bar track. Ensure the rectangular slot follower (05060024) has been installed onto the crossbar (see section 10.3.0). Install the power head bracket using the two 4 mm Allen bolts. **Note: APPLY ANTI SEIZE COMPOUND** on the four longer 6 mm Allen bolts.

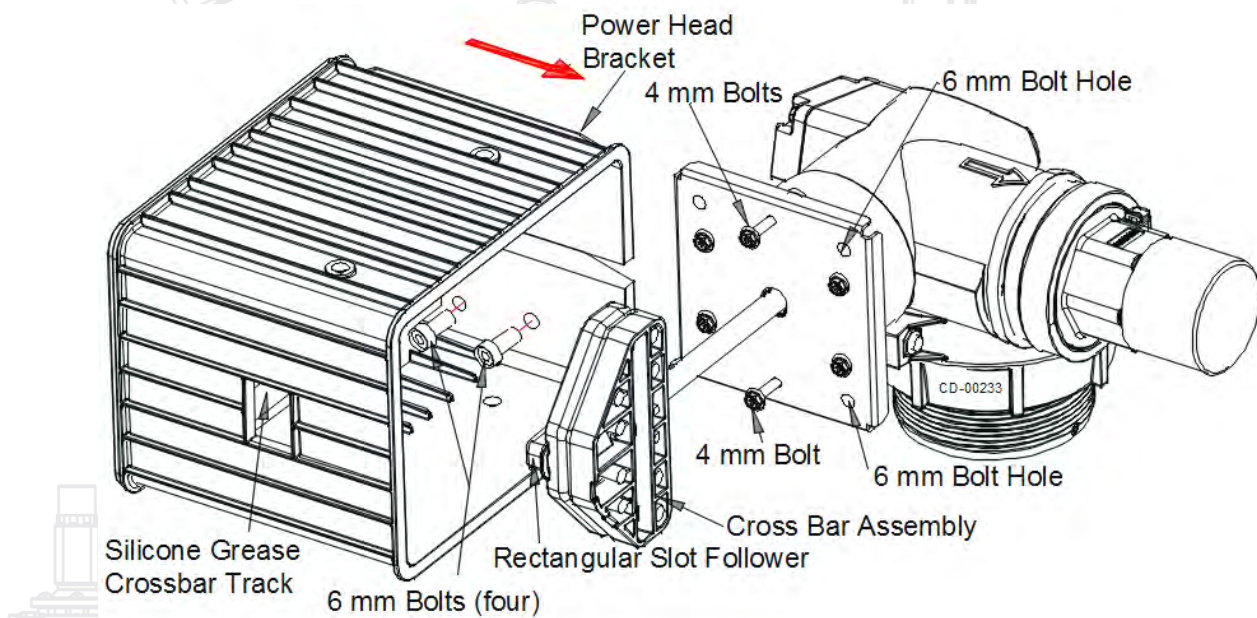

Align mark on power head bracket with cross bar assembly.

Lightly silicone grease cross bar track.

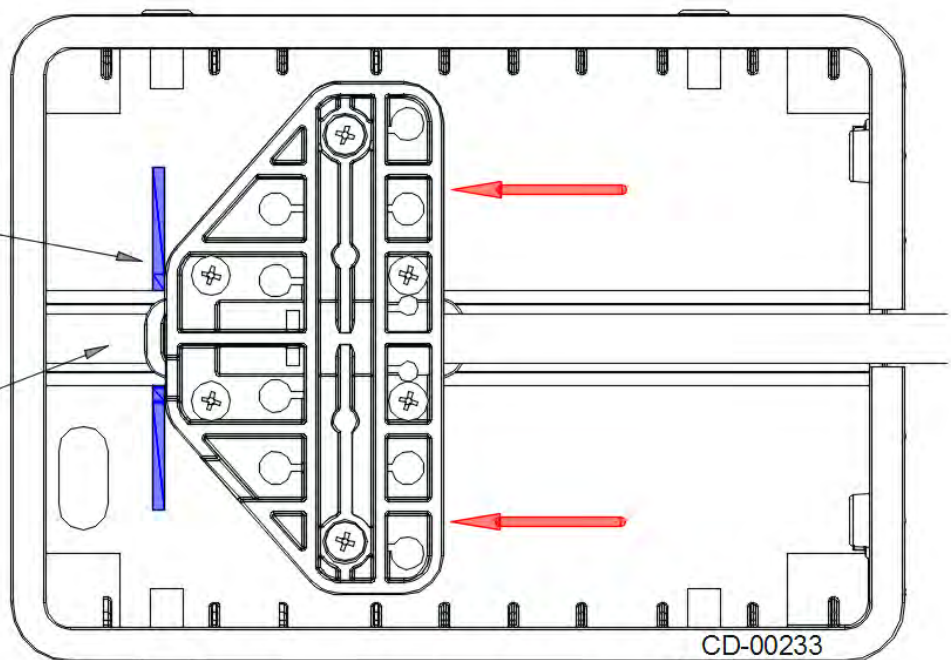

Piston / Seal / Spacer (Lantern Ring) Replacement

Section 9.2

- The motor drive assembly can now be installed. The motor cam gear must be installed at the **SERVICE** position as indicated by the arrow shown below.

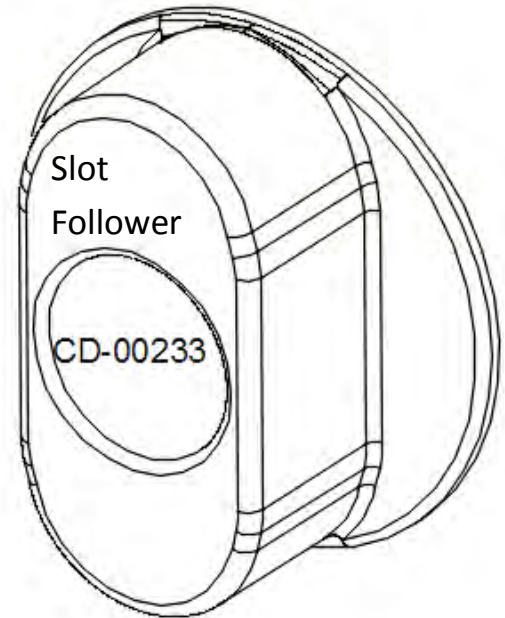
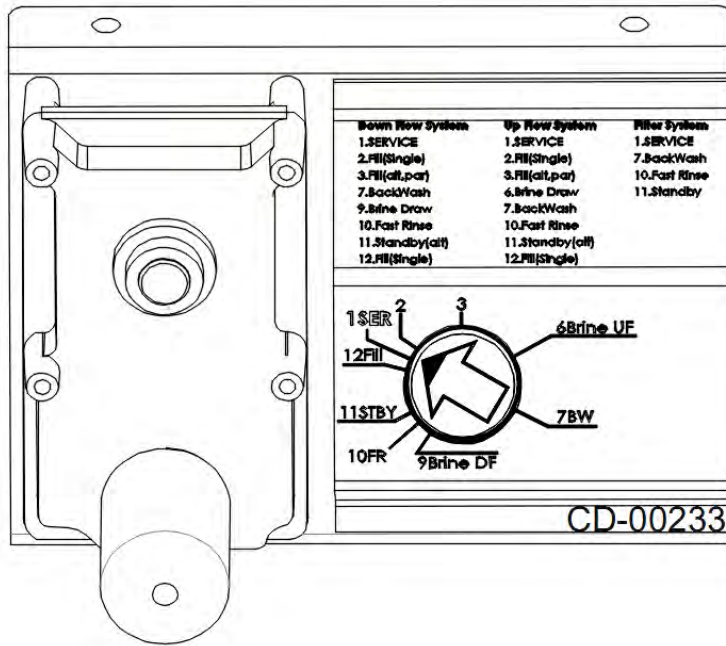

- The slot follower (05060023), must be at the **“3 O’clock”** position on the gear and vertical in orientation.

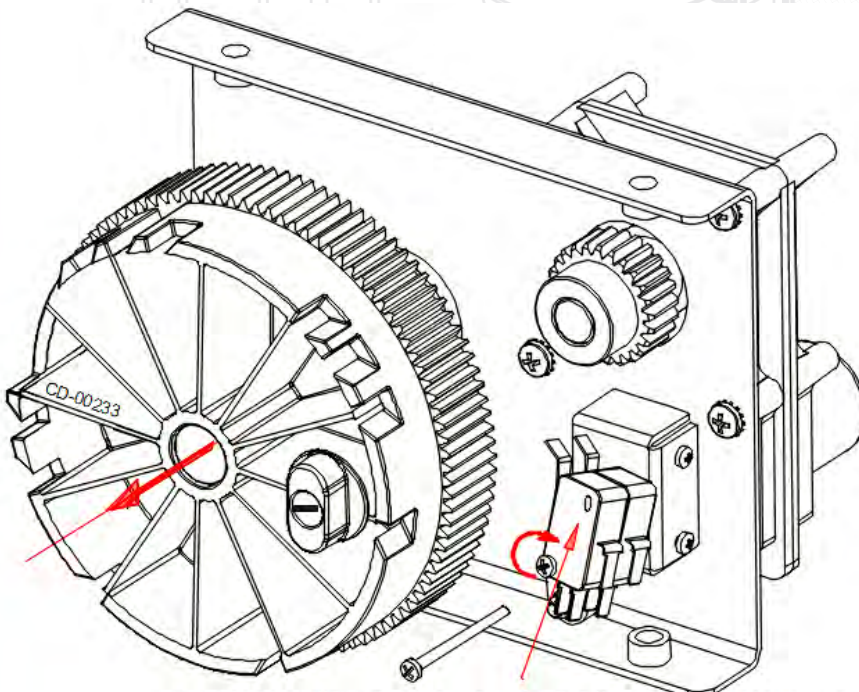

Remove top screw and rotate micro-switches so motor drive gear can be repositioned.

- If the motor cam gear is not in the correct orientation, remove the top micro-switch screw and rotate them out of the way. The motor gear can now be removed and positioned as required.

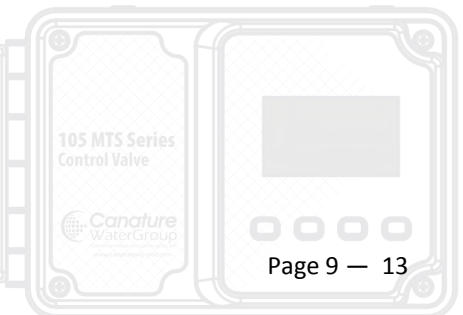

Piston / Seal / Spacer (Lantern Ring) Replacement

Section 9.2

- Apply silicone grease to the slot follower (05060023), the slot follower shaft, and the cross bar shaft guide. The silicone grease will also help hold the slot follower on it's shaft.

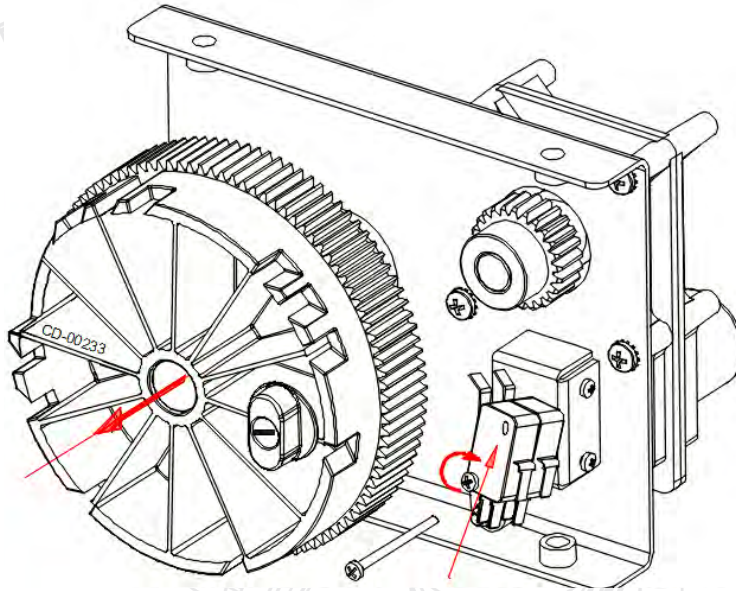

- Position the slot follower vertically on it's shaft as shown. Guide the motor drive and micro-switch wires through the power head housing as the motor assembly is slid in. The slot follower must slide into the cross bar vertical slot. Normally if the cross bar and the slot follower have been positioned as above, the motor assembly will slide right in. If you do have an issue, the slot follower can be viewed through the inspection window.

- NOTE: Use anti seize compound on the four 6 mm Allen bolts and use them to hold the motor assembly in place.

Align mark on power head bracket with cross bar assembly.

Lightly silicone grease cross bar vertical track.

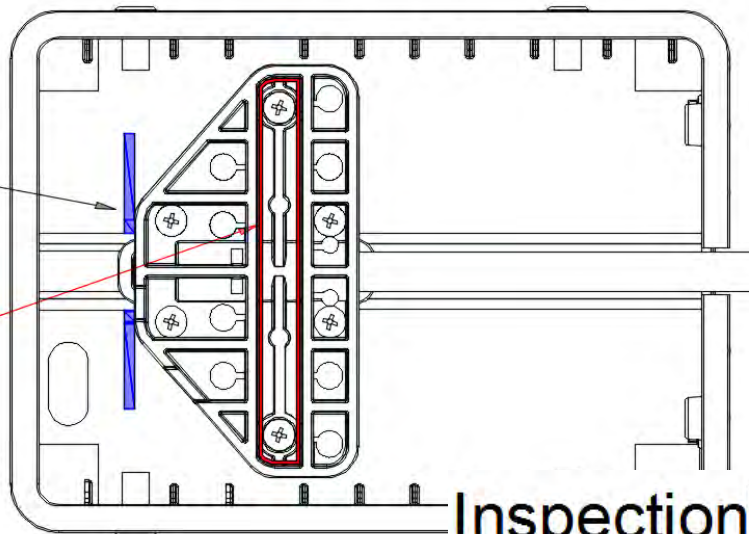

Inspection window

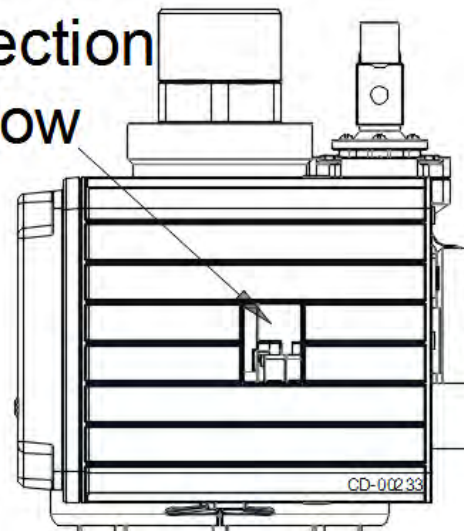

PCB / Drive Motor / Power Head Removal**Section 9.2**

- Connect the wires to the circuit board (PCB). The wire clips are color coded to make it simpler to wire. Refer to the circuit board diagrams in section 9.1 if you are unsure of any connections.
- Install the circuit board cover on to the power head bracket. Plug the system back in.

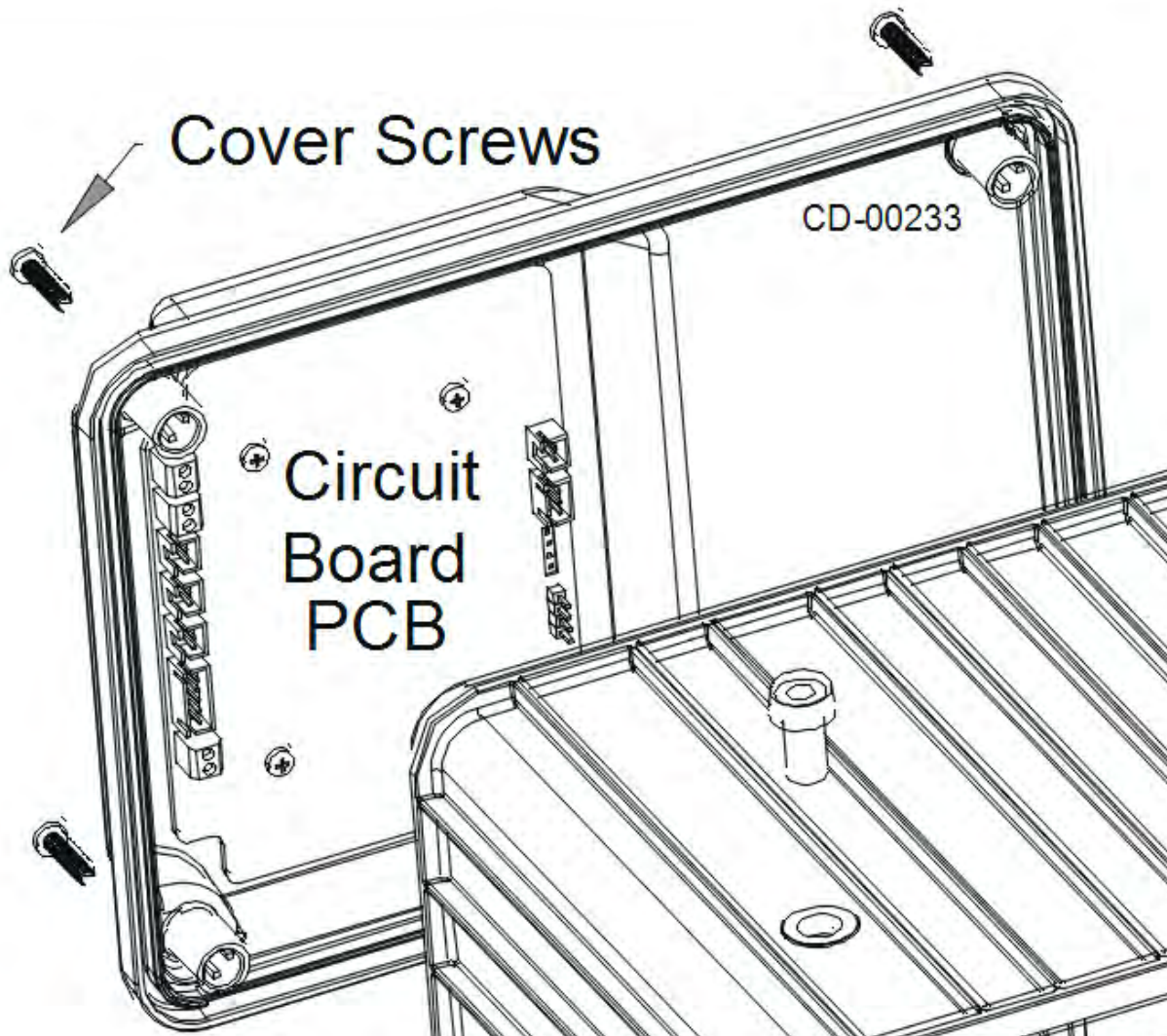

-If a new circuit board (PCB) has been installed, the system will have to be reprogrammed. Once the programming has been completed (if required), the system should be moved through a complete regeneration cycle to ensure everything is operating as intended.

PLEASE NOTE: *By stepping the control valve through a regeneration, the system assumed it has regenerated properly and will reset the capacity (or gallons) back to it's maximum. If the system was not fully regenerated when the system was cycled, a proper regeneration must be done.*

Clean / Replace Injectors, DLFC, BLFC, And Meter

Section 9.3

Caution: To prevent personal injury, or damage to the system, properly relieve the system pressure before doing any servicing on the control valve, piping or on the media tank.

-Turn off the water supply to valve and relieve the pressure inside as explained in section 9.0.1 & 9.0.2 before removing the meter and brine valve. It is also recommended to have the pressure off before removing the BLFC or DLFC .

-The DLFC (drain line flow control), has flow washers that control the maximum flowrate to the drain. If a button is missing or a larger flow washer than required is installed can result in too high of a backwash flowrate. This can result in some of the media backwashed out to drain.

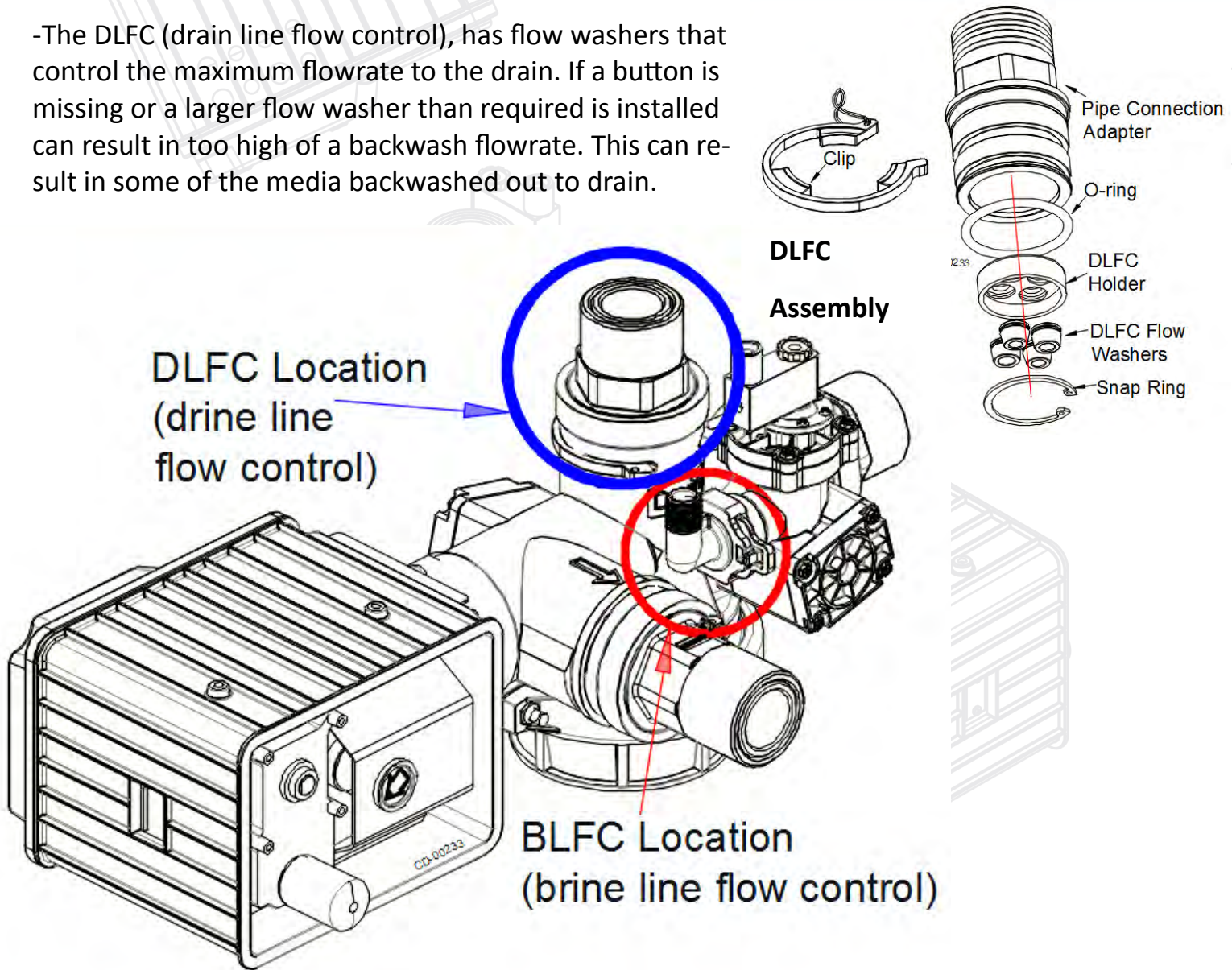

- The BLFC (brine line flow control), is located on the brine valve assembly and controls the refill flow rate to the brine tank.

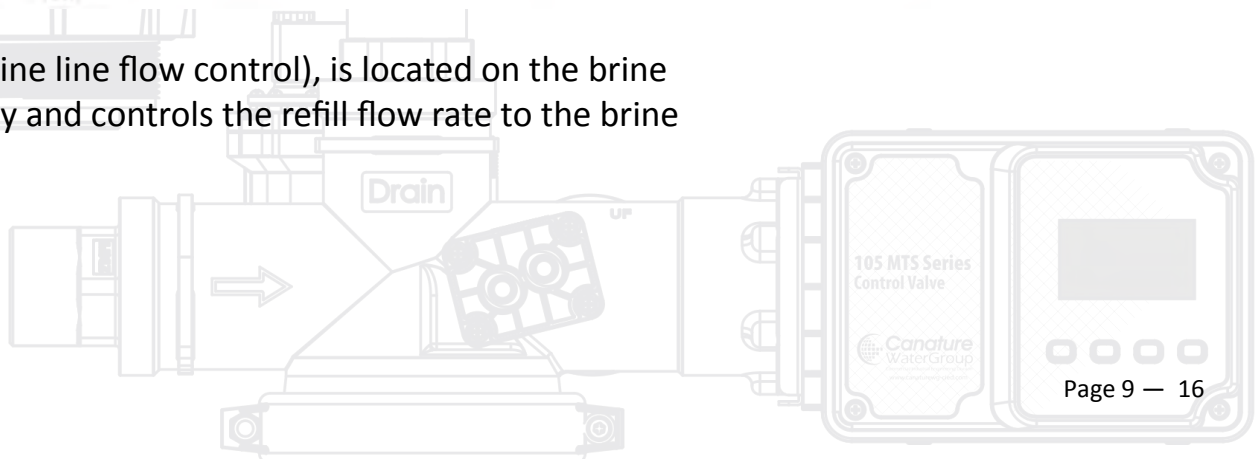

Clean / Replace Injectors, DLFC, BLFC, And Meter

Section 9.3

Caution: To prevent personal injury, or damage to the system, properly relieve the system pressure before doing any servicing on the control valve, piping or on the media tank.

-Turn off the water supply to valve and relieve the pressure inside as explained in section 9.0.1 & 9.0.2 before removing the meter and / or the brine valve.

-The meter is an integral part of the outlet piping connection adapter. It can be easily taken apart to be cleaned. The meter and meter turbine will only fit one way so it can not be accidentally reversed.

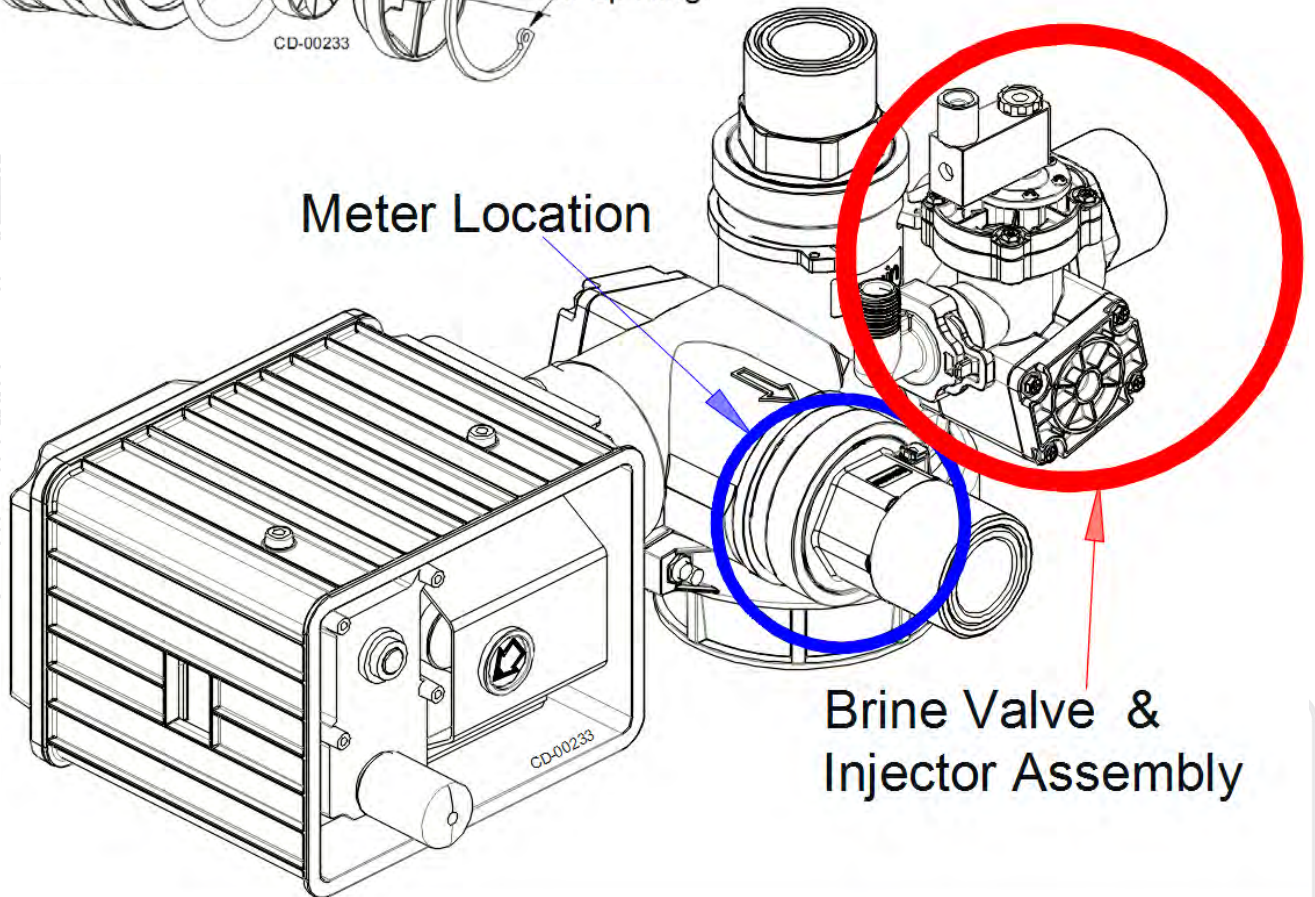
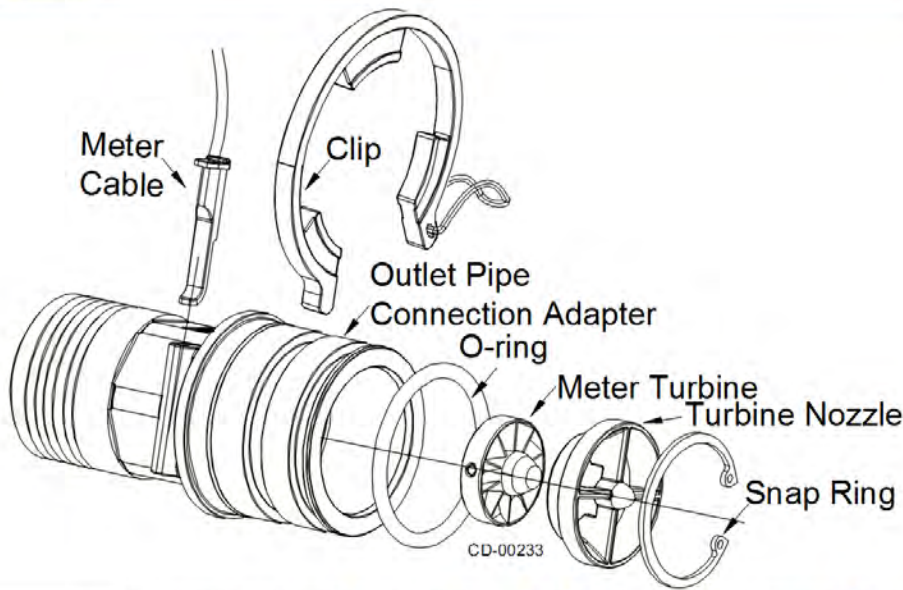

Clean / Replace Injectors, DLFC, BLFC, And Meter**Section 9.3**

Caution: To prevent personal injury, or damage to the system, properly relieve the system pressure before doing any servicing on the control valve, piping or on the media tank.

- Sediment, salt and silt will restrict or clog the injector. A clean water supply and pure salt will prevent this from happening.
- Disconnect the brine line by removing the clip on the BLFC housing and pulling the housing out. Also disconnect the brine solenoid wiring by using a Philips screw driver and unthreaded the connector from the solenoid.
- Remove the four bolts holding the injector body on (use Phillips or 8 mm socket), and remove the injector assembly.

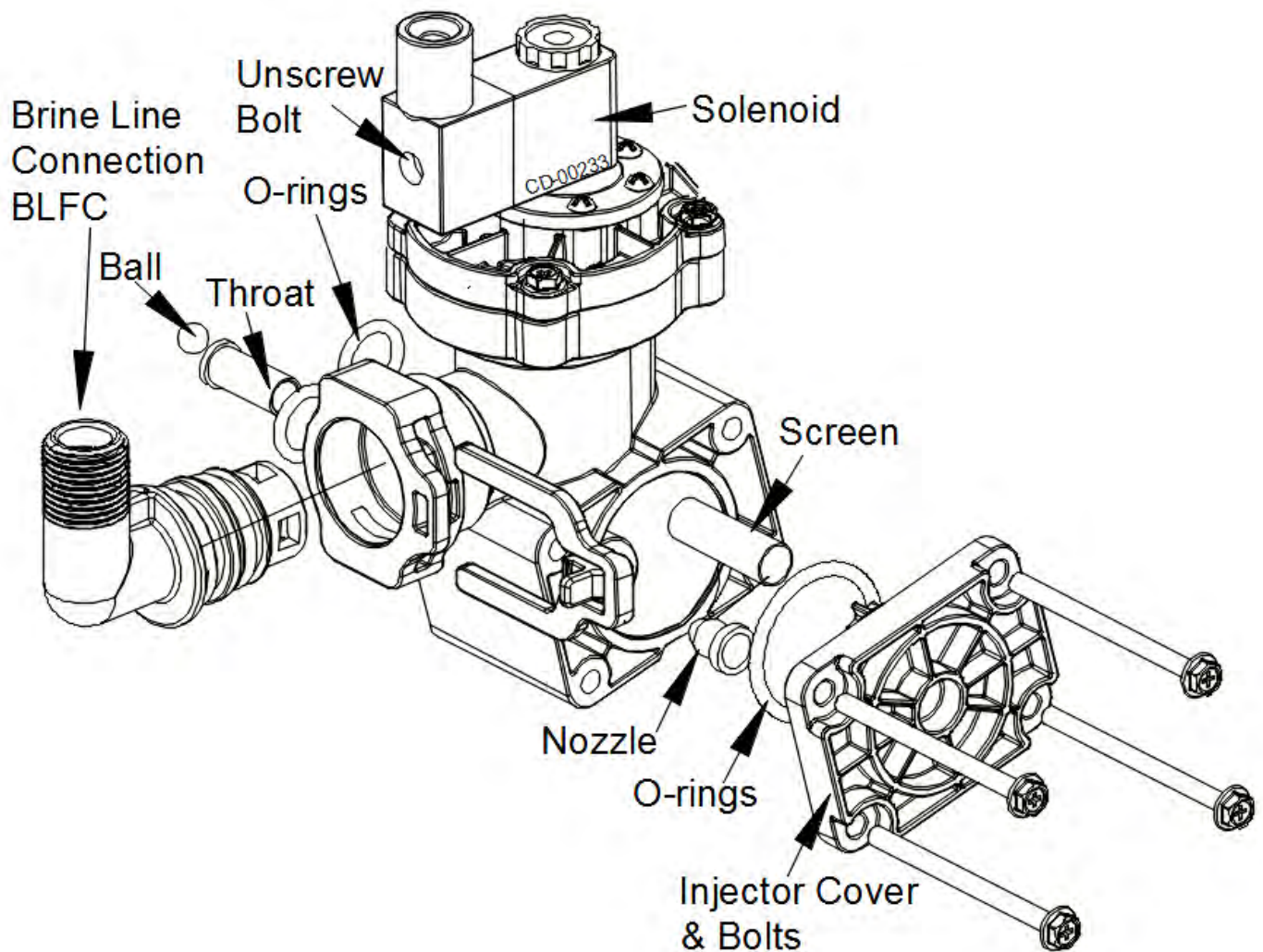

- The screen, throat and nozzle can be removed & cleaned. The throat & ball is removed from the back and the nozzle & screen is removed from the front. After cleaning, reassemble the injector assembly. Ensure all O-rings are lightly greased and installed correctly. See section 9.4 for recommended procedures for installing O-rings.

Installing O-rings

Section 9.4

If any O-ring is not installed properly, there is a good chance the connection will leak. The way to install an O-ring depends upon the actual connection itself.

There are two main types of O-ring connections:

- #1- Connections that do NOT have a O-ring groove on the part connections.
- #2- Connections that have an actual groove for the O-ring on part connections.

When installing the O-rings on connections that do NOT have an O-ring groove (#1), the procedure is as follows:

- Inspect the O-ring for any nicks or cuts. If any are found, replace the O-ring.
- Use food grade silicone grease to lightly coat the O-ring and all surfaces the O-ring will contact (both the male & female surfaces).
- Install the O-ring on the MALE connection & ensure that the O-ring is not twisted.
- Install all other required parts and slide the connection together.

Pictured below is a diagram reflecting example #1.

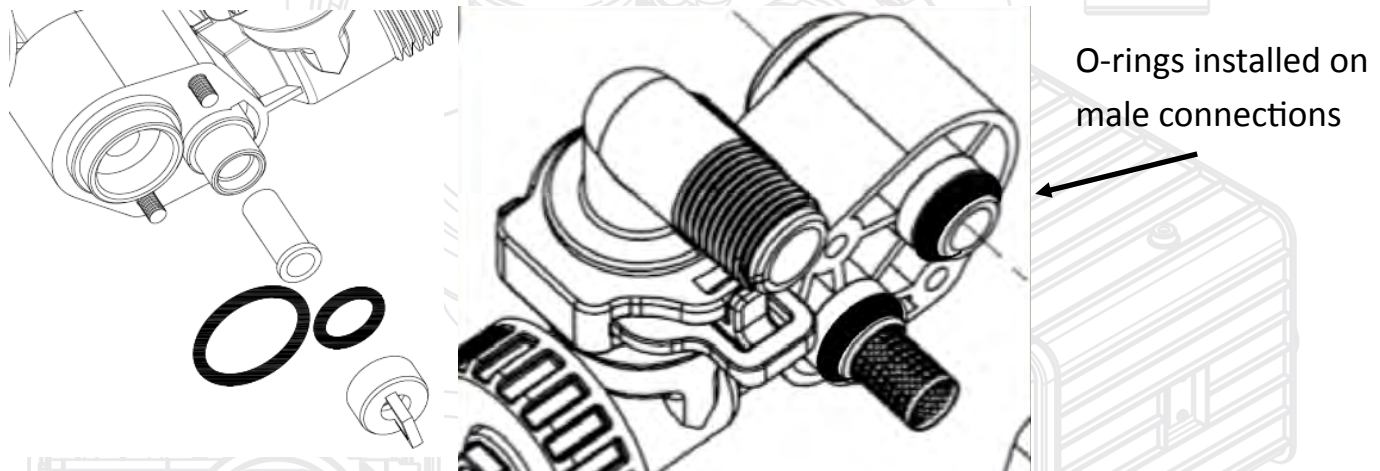

Pictured below and to the right is a diagram reflecting example #2.

In this situation, there is a groove designed into the connection for the O-ring to be seated into place.

Installation procedure is as follows:

- Inspect the O-ring for any nicks or cuts. If any are found, replace the O-ring.
- Use food grade silicone grease to lightly coat the O-ring and all surfaces O-ring will contact (both the male & female surfaces).
- Install the O-ring into the appropriate groove on the connection.
- Ensuring the O-ring is not twisted, slide the connection together.

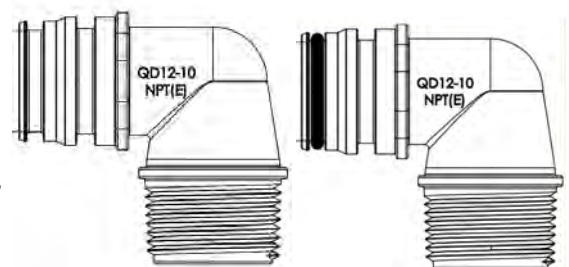

Repair Parts –Tanks

Section 10.1

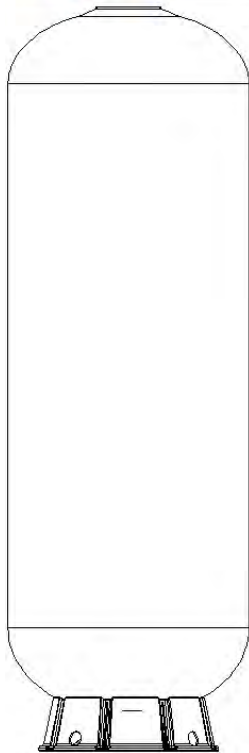

Section 10.1	MINERAL TANKS	Part Number
14" Diameter x 65" Natural	4" Threaded Top Hole Std Base	25030001
16" Diameter x 65" Natural	4" Threaded Top Hole Std Base	25030002
18" Diameter x 65" Natural	4" Threaded Top Hole Std Base	25030014
21" Diameter x 62" Natural	4" Threaded Top Hole Std Base	25030003
24" Diameter x 72" Natural	4" Threaded Top Hole Std Base	25030004
30" Diameter x 72" Natural	4" Top & Bottom Hole Tripod Base *	25030030
30" Diameter x 72" Natural	6" Top & Bottom Flanged Tripod Base	25030033
36" Diameter x 72" Natural	4" Top & Bottom Hole Tripod Base *	25030040
36" Diameter x 72" Natural	6" top & bottom flanged tripod base	25030043
Tank Closures, Adapters and Accessories		
Adaptor, Tank, 4" Thread X 2-1/2" Thread CANATURE		50040039
O-ring #342 Replacement For Above		15210
4" Thread Tank Closure		50040075
6" FLANGE CLOSURE JD 506 c/w Bolt Kit		50040148
6" FLANGE CLOSURE WITH 4" THREAD JD507 c/w Bolt Kit		50040149
Bolt Kit For 6" Flanges 12-5/16" x3" Long SS Nuts & Washers		97000738
Flexible Piping Connectors. (Required with rigid piping)		
Connector, Flex, 1.25"x18"L *(Stock)		80127822
Connector, Flex, 1.25"x24"L		80127823
Connector, Flex, 1.5"x18"L *(Stock)		80127824
Connector, Flex, 1.5"x24"L		80127825
Connector, Flex, 2"x18"L *(Stock)		80127826
Connector, Flex, 2"x24"L		80127827
Vacuum Breaker, 1.5" MNPT		310527
VALVE VACUUM BREAKER 1/2" NPT 12N36		60020204
Vent, Air release Braukman 1/8" MNPT		50701
* Non Standard Tank		all units mvs.xlsx

Repair Parts –Distributions

Section 10.2

Section 10.2	DISTRIBUTION	Part Number
For Top Mounted Control Valves (No Riser Pipe Is Included)		
High Flow Hub & Laterals 13"-16" JD 324 (1.5" Riser Not Included)		50040160
HIGH FLOW HUB & LATERALS 18"-21" JD 306 (1.5" Riser Not Included)		50040161
HIGH FLOW HUB & LATERALS 24" JD 307 (1.5" Riser Not Included)		50040117
HIGH FLOW HUB & LATERALS 30" JD 308 (1.5" Riser Not included)		50040118
HIGH FLOW HUB & LATERALS 36" (1.5" Riser Not Included)		50040119
Adapters & Pipe For Top Mounted Valve Distributions		
1.5" Sch 40 Pipe (NOTE Sold By The Foot)		1120066

105 Valve Repair Parts

Section 10.3.0

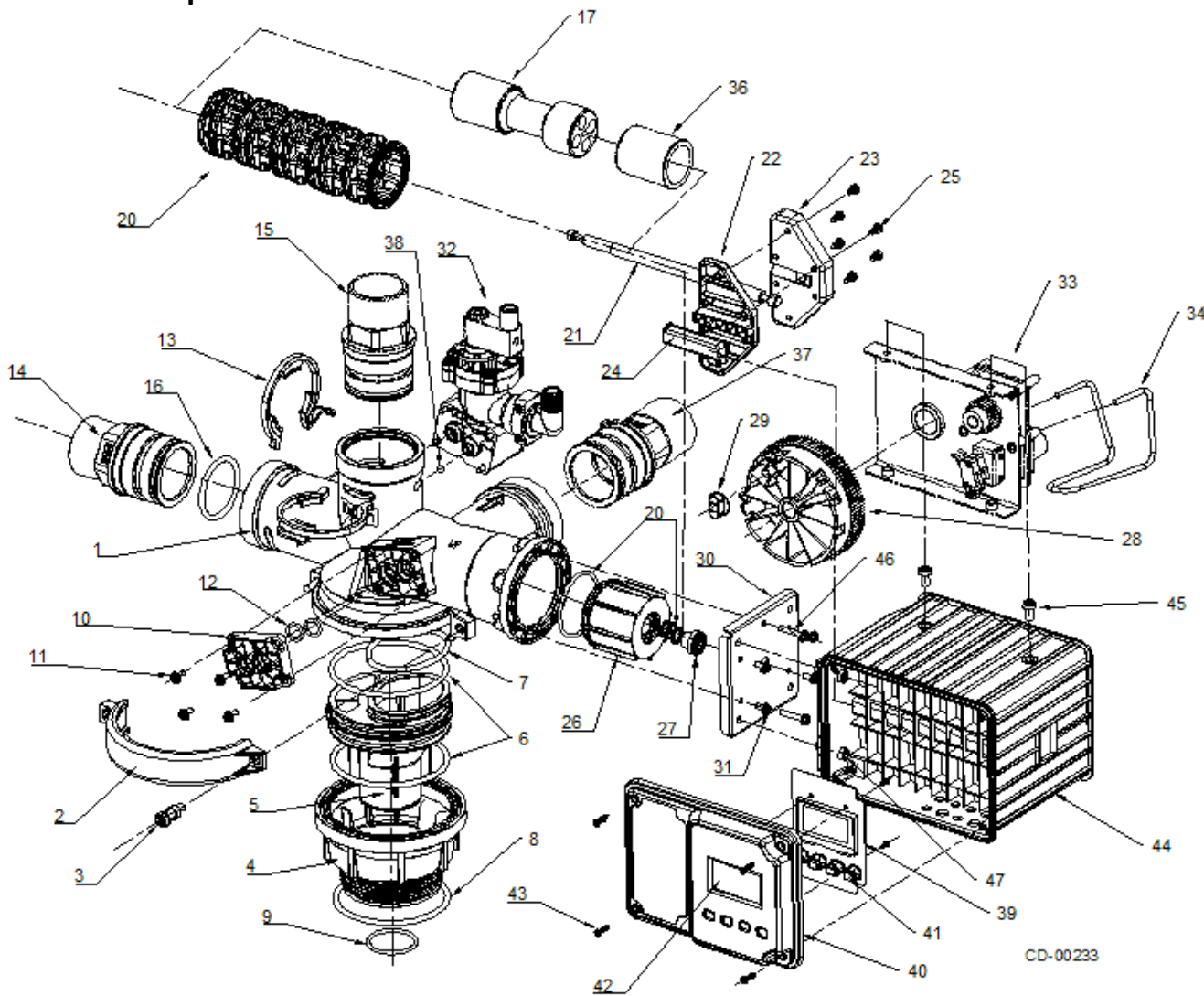

Drawing 10.3.0 item number	Description	Quantity
14 - 15	105 End adapters /DLFC kits See section 10.3.4	1
20	105 Seal & spacer (lantern) kits See section 10.3.2	1
32	105 Aspirator kits See section 10.3.1	1
33	105 motor assemblies See section 10.3.3	1
37	105 Meter adapters See section 10.3.5	1
39	105 Circuit boards and cables See section 10.3.6	1
05060002-K Kit,105,tank adaptor 02170302		
9	O ring 46.99x5.33 1.9"OD	1
4	Tank adaptor 105	1
5	Support, rise pipe 1.9"OD	1
7	O ring 75.57x5.33	1
6	O ring 110.49x5.33	2
3	Bolt M8x25	2
2	Clamp,victaulic ,105	2
3	#8 spring washer	2
3	Nut M8	2
8	O-ring 108X5.3 4" valve base	1
Not shown	Silicone grease 1 gram package	1

105 Valve Repair Parts

Section 10.3.0

10.3.0 item number	Description	Quantity
05060002-O Kit,105,o-rings,tank adapter 02170305		
9	O ring 46.99x5.33 1.9"OD	1
7	O ring 75.57x5.33	1
6	O ring 110.49x5.33	2
8	O-RING 108X5.3 05040094	1
Not shown	Silicone grease 1 gram package	1
05060015-K Kit,105,plug,aspirator filter 02170296		
10	Aspirator plug	1
11	Screw,cover, bolt M5-12	4
12	O-ring,14X3 05040084	2
Not shown	Silicone grease 1 gram package	1
05060037-B Kit,105,bolts,powerhead 02170300		
46	Bolt M5x30	2
45	Bolt M8x14	4
47	Bolt M8x30	4
Not shown	Washer 5*15 (for 47)	2
43	Screw ST3.5x22	4
39	SCREW ST2.9X9.5	4
05060081-K Kit,105,piston rod assembly 02170304		
22	Crossbar, top	1
23	Crossbar, bottom	1
29	Slot follower	1
24	Slot follower, rectangle	1
25	Screw ST4.8x13	6
21	Piston rod	1
Not shown	Silicone grease 1 gram package	1
05060021-K Kit,105,end plug assembly 02170299		
46	Bolt M5x30	2
26	End plug	1
27	Flanged Bushing	1
part of 20	Quad ring 12.37x2.62	2
part of 20	O ring 63.09x3.53	1
part of 20	Washer 5*15	2
part of 20	Retainer,insert,105 End	1
31	Screw,cover. Bolt M5-12	4
Not shown	Silicone grease 1 gram package	1
05060009-R Kits 105 Piston Assembly RWB		
17	Piston 105	1
05060081-K	Kit,105,piston rod assembly	1
05060021-K	Kit,105,end plug assembly	1
05060009-N Kits 105 Piston Assembly NRW		
17	Piston 105	1
36	Trailer piston	1
05060081-K	Kit,105,piston rod assembly	1
05060021-K	Kit,105,end plug assembly	1

105 Valve Repair Parts

Section 10.3.0

<i>Item</i>	<i>Description</i>	<i>Quantity</i>	
1	Body, valve 105	1	
2	Clamp, Victaulic ,105	2	
	Bolt M8x25	2	
3	Φ8 spring washer	2	
	Nut M8	2	
4	Tank adaptor 105	1	
5	Support, Rise pipe 105	1	
	Support, RisePipe 1.9"OD		
	O ring retainer	1	
6	O ring 110.49x5.33	2	
7	O ring 75.57x5.33	1	
8	O ring 108x5.3	1	60010228
9	O ring 46.99x5.33 1.9"OD	1	05042005
10	Aspirator plug	1	
11	Bolt M5x12	4	
12	O ring Φ14x3	2	
13	C Clip (also requires 05060125 below)	3	05060026
	C Clip tightener	3	05060125
14	Adapter, 2.0" NPT (also requires 05060058)		05060031
	Adapter, 1.5" NPT (also requires 05060058)		05060034
15	Adapter Drain ASM W/ DLFC	1	See section 10.3.4
16	O ring 56.52x5.33	3	05060058
17	Piston, 105 Valve	1	05060009
20	Kit, Seal, Spacer 105 valve	1	05060134M
21	Piston Rod	1	
22	Crossbar, Top	1	
23	Crossbar, Bottom	1	
24	Slot follower, Rectangle	1	05060024
25	Screw ST4.8x13	6	
26	End plug	1	
27	Flanged Bushing	1	
28	Cam & Gear with Pin	1	
29	Slot follower	1	05060023
30	End plug plate	1	
31	Bolt M5x12	4	
32	Valve, Brine Assy 105 Valve	1	See section 10.3.1
33	Inner Bracket Assembly	1	
34	Motor Frame	1	
35	O ring 41x1.78	1	
36	Trailer piston	1	05060010
37	Meter/Conn, 105V-2" NPT Outlet W/ Meter Assembly		See section 10.3.5
37	Meter/Conn, 105V-1.5" NPT Outlet W/ Meter Assembly		See section 10.3.5
38	Throat Check ball	1	05060140

105 Valve Repair Parts

Section 10.3.0

<i>Item</i>	<i>Description</i>	<i>Quantity</i>	
39	Circuit board, PCB	1	See section 10.3.6
	Screw ST2.9x9.5	4	
40	Wire cover	1	
41	Rubber button	4	
42	Clear panel	1	
43	Screw ST3.5x22	4	
44	Plastic Outer Bracket	1	05060037
45	Bolt M8x14	4	
46	Bolt M5x30	2	
	Washer 5*15	2	
47	Bolt M8x30	4	
48	Wire harness --Not shown	1	See section 10.3.6
Not shown	Silicone grease 8 oz tube	1	1014081
			105 Modified-Sub assemblies.xlsx

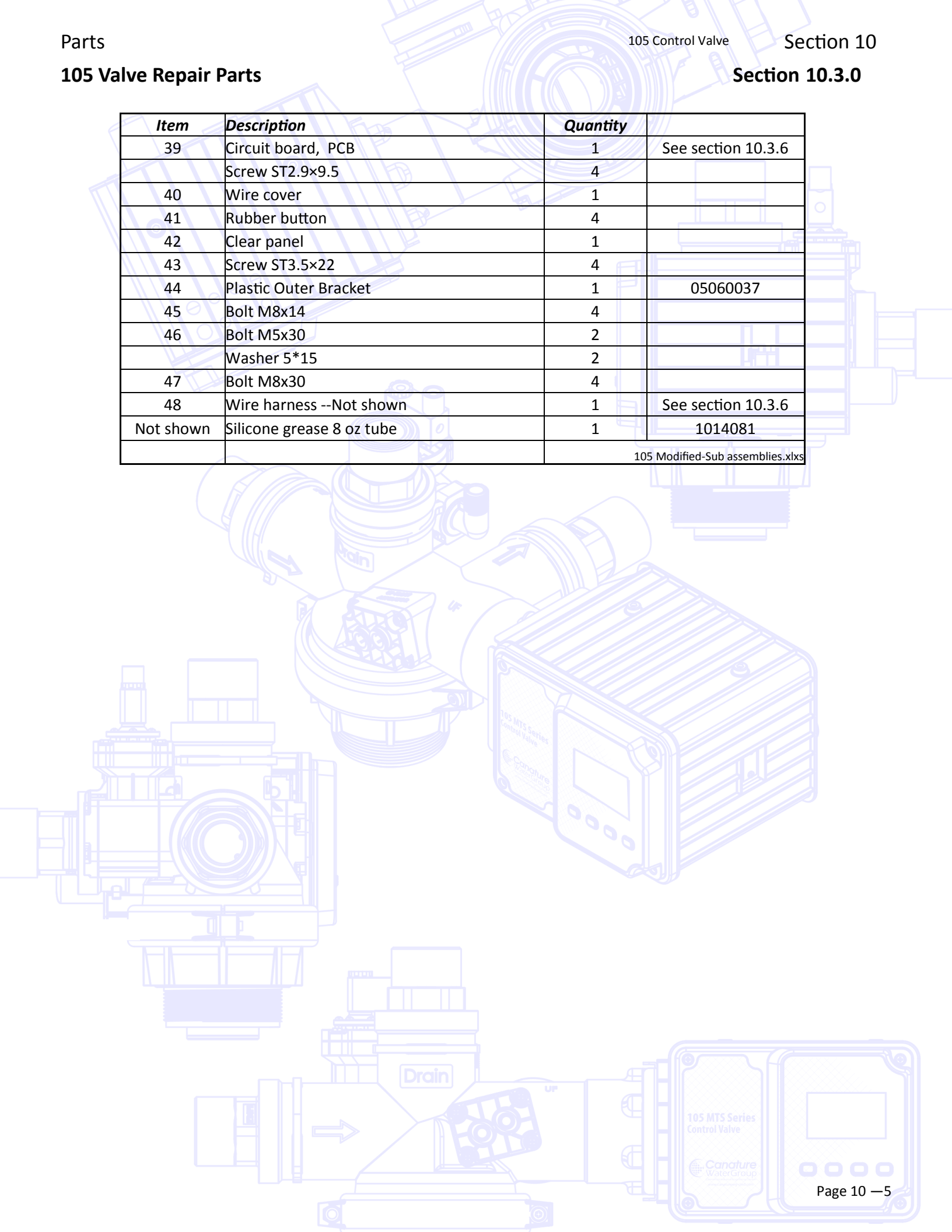

105 Brine Valve & Injector Assembly

Section 10.3.1

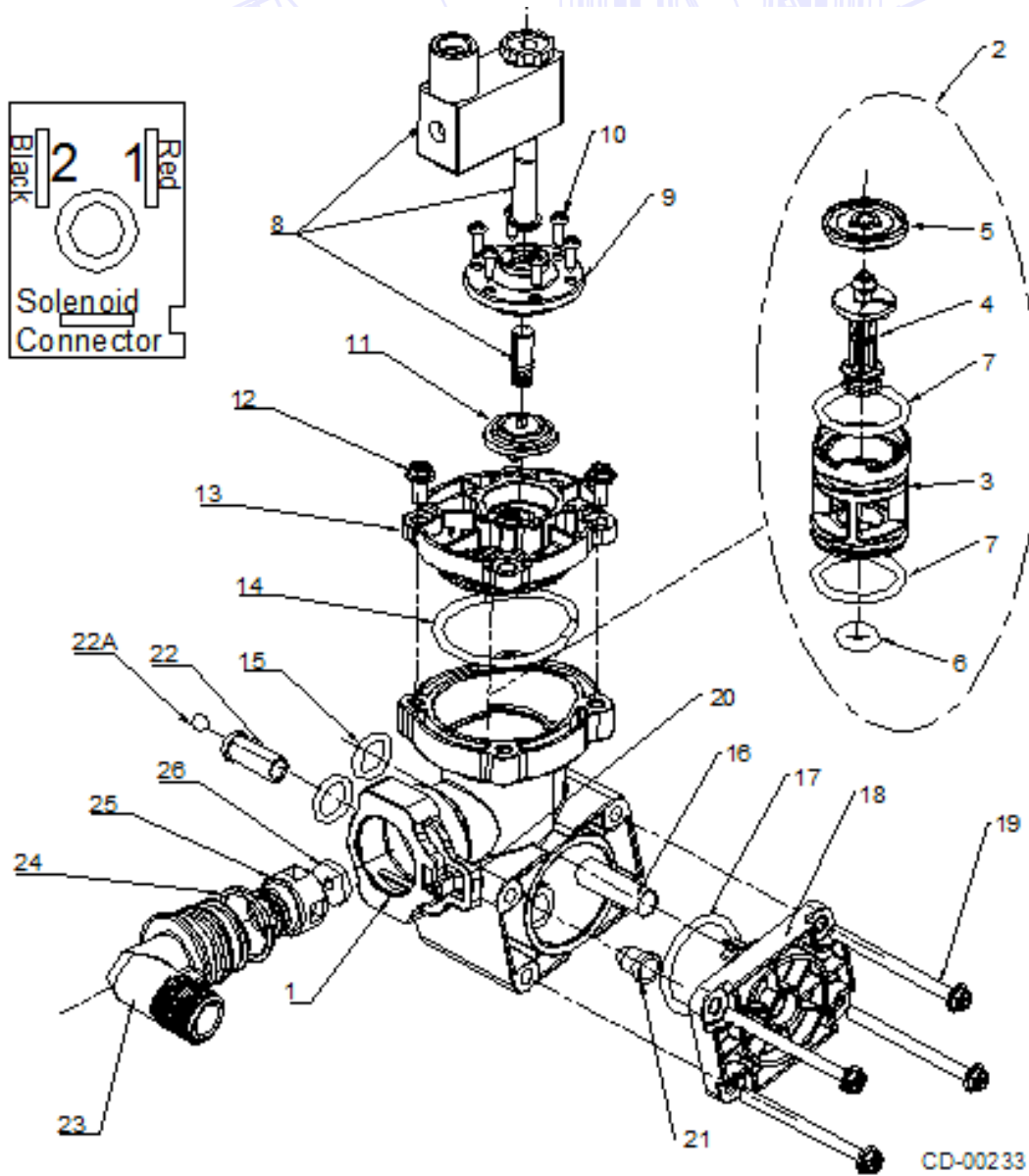

All items on above drawing		05060105-T Kit, complete 105 aspirator c/w solenoid, wiring harness and injectors	
10.3.1	Item	05060105-P Kit, aspirator bolt	Quantity
	#10	Screw ST3.5×13	6
	#12	Bolt M5×16	4
	#19	Bolt M5×68	4
		05060105-O Kit, aspirator o-rings	
	17	O ring 34.52×3.53	1
	14	O ring 40.87×3.53	1
	16	Screen, nozzle	1
	22A	Throat check ball,71mm	1
	24	O-ring,drain,	1
	15	O-ring,14X3 05040084	2
	Not shown	Silicone grease 1 gram package	1

105 Aspirator -Brine Valve & Injector Assembly

Section 10.3.1

Item	Description	Quantity	Part #
1	Aspirator Housing	1	
2	Brine Plunger Assembly	1	
3	Retainer Housing	1	
4	Plunger	1	
5	Plunger Diaphragm	1	
6	O ring 8x4.8	1	
7	O ring 29.74x3.53	2	
8	Solenoid Coil 24VDC Assembly	1	
	Solenoid Harness Not Shown #1 Red; #2 Black	1	
9	Mounting Plate	1	
10	Screw ST3.5x13	6	
11	Solenoid Diaphragm	1	
12	Bolt M5x16	4	
13	Aspirator Cap	1	
14	O ring 40.87x3.53	1	
15	O ring Φ 14x3	2	
16	Screen, Nozzle	1	05060068
17	O ring 34.52x3.53	1	
18	Aspirator Housing Plug	1	
19	Bolt M5x68	4	
20	95 Clip	1	92380
	Kit, Nozzle/BLFC all Items 21 to 22A + all 26 & 27	1	60010150K
21	Nozzle Black 5s	1	60010154
&	Throat Orange 5s	1	60010156
22	Nozzle Gray 1#	1	60095043
	Throat Gray 1#	1	60095047
	Nozzle purple 2#	1	05040057
	Throat purple 2#	1	05040058
	Nozzle Red 3#	1	60010151
	Throat Red 3#	1	60010157
	Nozzle White 4#	1	60010152
	Throat White 4#	1	60010158
22A	Throat Check ball,71mm	1	5060140
23	95 Brine Elbow	1	60010232
24	O ring (EPDM)25x3	1	60010211
25	95 BLFC Retainer	1	12054
26	BLFC 6# 0.95gpm	1	60010161
	BLFC 7# 1.5gpm	1	60010162
	BLFC 1# 2.0gpm	1	12053
	BLFC 2# 2.5gpm	1	05040077
	BLFC 3# 3.0gpm	1	05040078
	Brine line connectors		
27 Not shown	Connector 1/2" BSPx3/8" tube	1	60010217
27 Not shown	Connector 1/2" BSPx1/2" tube	1	60010230
Not shown	Tee,nylon 3/8" tube	1	80033203
Not shown	Tee,nylon 1/2" tube	1	80033212
Not Shown	Silicone grease 8oz tube	1	1014081

105 modified-sub assy.xlsx

Piston / Seal / Spacer (Lantern Ring) Replacement

Section 10.3.2

- See section 9.0 to 9.3 for seal replacement procedures.

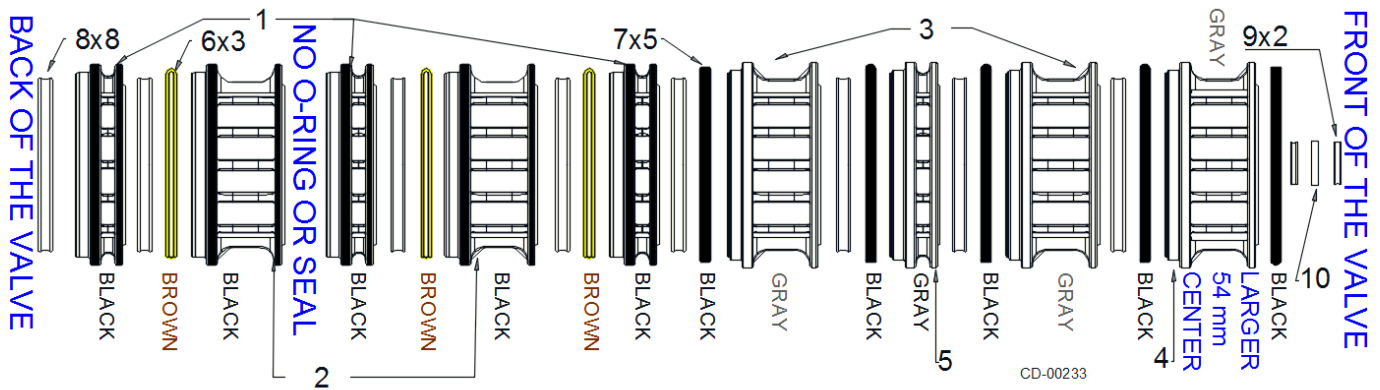
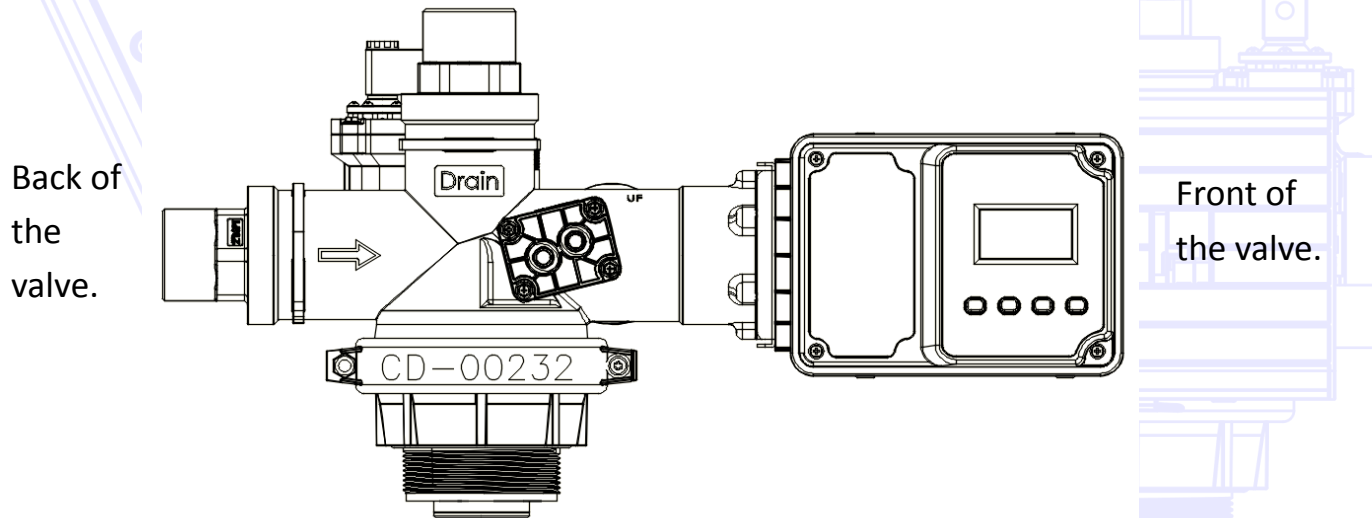

Internal Rebuild Kit - includes items 1 to 10 only #05060134M			
10.3.2	Item	Description	Quantity
	1	Lantern ring I (spacer) Black 50 mm	3
	2	Lantern ring II (spacer) Black 50 mm	2
	3	Lantern ring III (spacer) Gray 50 mm	2
	4	Lantern ring V (spacer) Gray 54 mm	1
	5	Lantern ring IV (spacer) Gray 50 mm	1
	6	O ring 59.92x3.53 Brown	3
	7	O ring 63.09x3.53 Black	5
	8	Quad ring 50.17x5.33 Black	2
	9	Quad ring 12.37x2.62	1
	10	Quad ring gasket	1
	Sold separately	Stuffer/puller tool (required when changing internals) #70020033	

105 modified-sub assy.xls

105 MTS Series Control Valve

Canature Watergroup

105 Internal Motor Bracket Assembly

Section 10.3.3

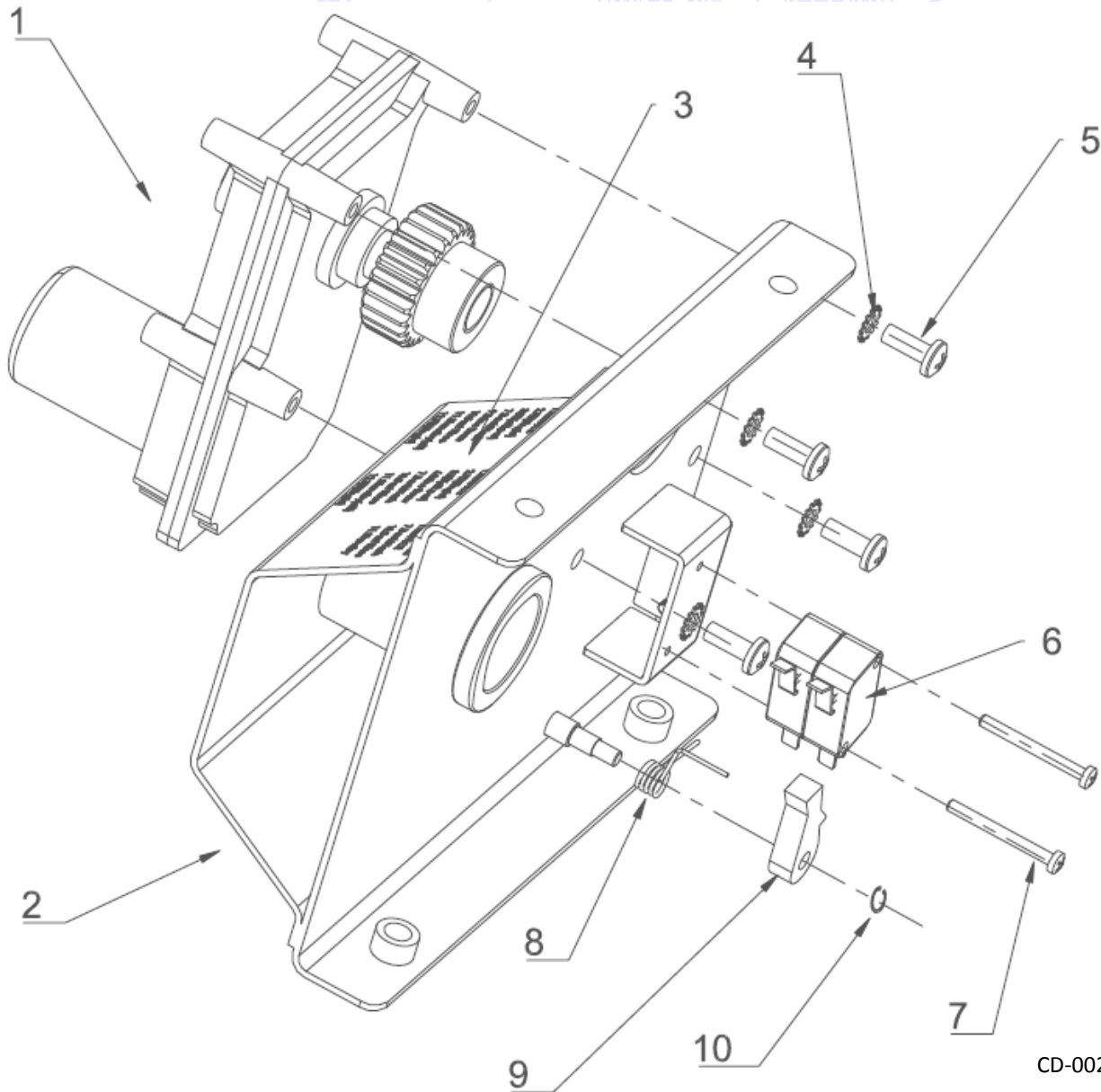

CD-00233

10.3.3 Item	Description	Quantity	
1	Motor assembly c/w gear	1	05060102
2	Inner Bracket	1	
3	Decal	1	
62000607-K Kit,105 microswitch 02170297			
4	10# washer	4	
5	Screw #10-32UNF0.5"	4	
6	Micro-switch EWS	2	
7	SCREW,MICROSWITCH	2	
8	Spring, Anti Reverse	1	
9	Anti Reverse pawl	1	
10	Snap clip 3.5	1	
Not Shown	Cable, Micro Switch,	1	
Complete assembly items 1 to 10			05060124

105 modified-sub assy.xlsx

105 Drain Line Flow Control Assembly (DLFC)

Section 10.3.4

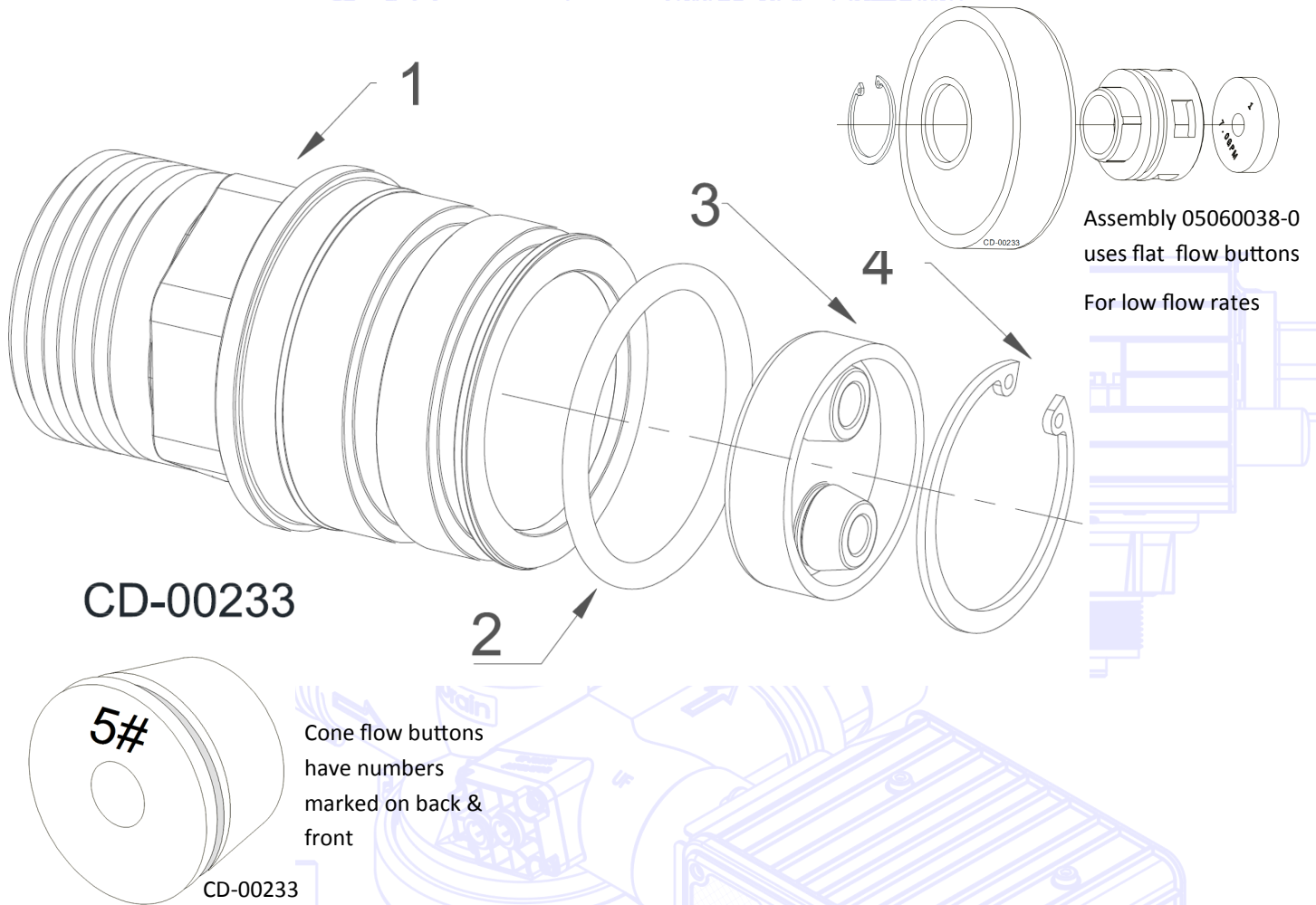

Item	PART NUMBER	Description		Qty
1	05060032	2.0" NPT adapter	105 Valve	1
1	05060034	1.5" NPT adapter	105 Valve	1
2	05060058	O ring 56.52x5.33	105 Valve	1
3	05060127	DLFC 1# ASM-12gpm	105 Valve	1
	05060128	DLFC 2# ASM-15gpm	105 Valve	1
	05060129	DLFC 3# ASM-20gpm	105 Valve	1
	05060130	DLFC 4# ASM-30gpm	105 Valve	1
	05060131	DLFC 5# ASM-40gpm	105 Valve	1
	05060132	DLFC 6# ASM-56gpm	105 Valve	1
4	05060077	Snap clip Φ52	105 Valve	1
	05060038-0	DLFC PlugPlate Using Flat Flow Buttons		
	05060038C	DLFC,PlugPlate105V 1Hole	No Plug 105 valve 2"Dia	
	05060038B	DLFC,PlugPlate105V 2Hole	No Plugs 105 valve 2"Dia	
	05060038	DLFC,PlugPlate105V 4Hole	No Plugs 105 valve 2"Dia	
	05060095	DLFC,Flow Plug 8gpm-#4	105valve 0.6"Diameter.3H	
	05060096	DLFC,Flow Plug 12gpm-#5	105valve 0.9"Diameter.6H	
	05060097	DLFC,Flow Plug 15gpm-#6	105valve 0.9"Diameter.6H	
	05060126	DLFC,Flow Plug 20gpm-#7	105valve 0.9"Diameter.6H	

105 Outlet Adapter C/W Meter Assembly

Section 10.3.5

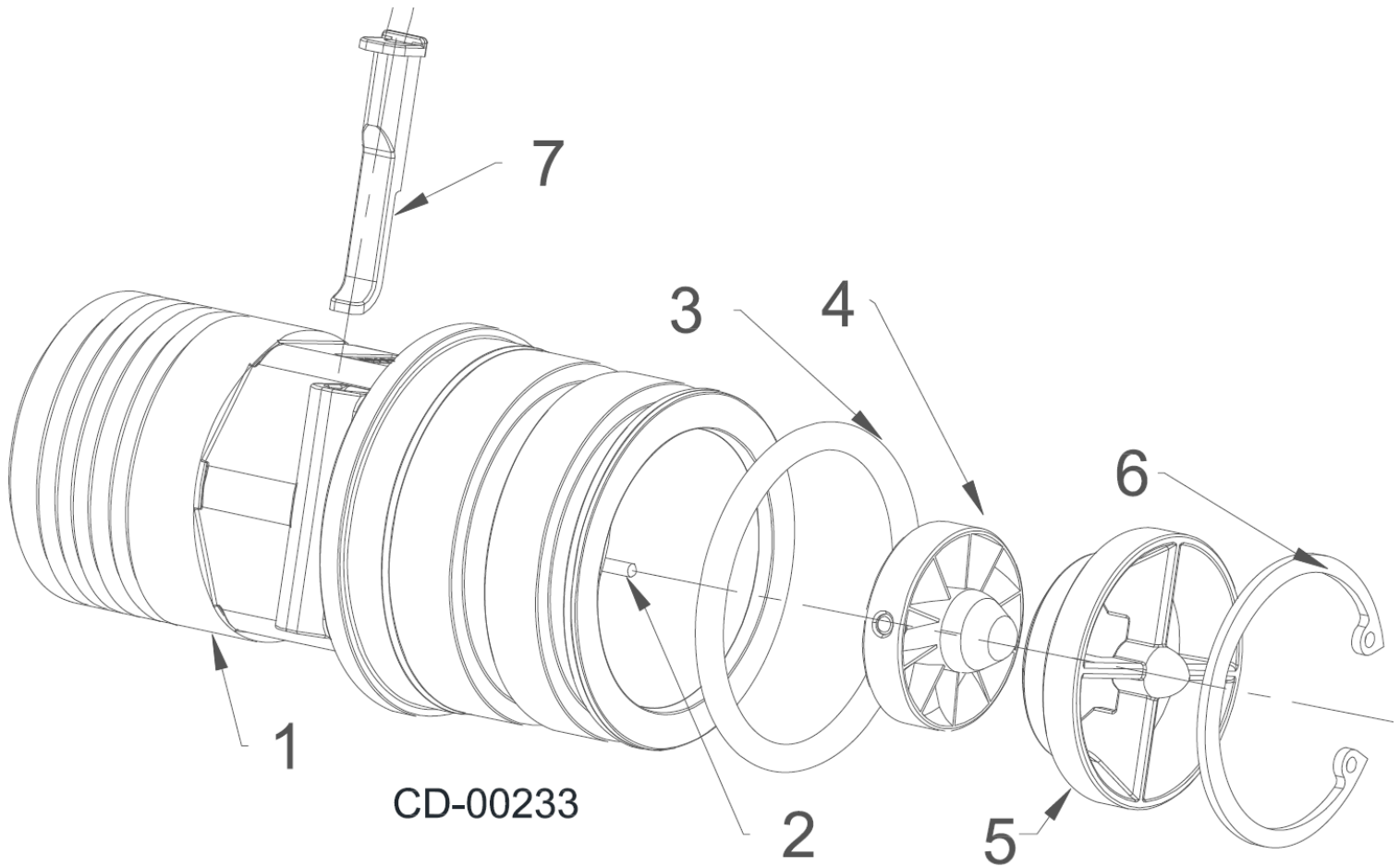

<i>Item</i>	<i>Description</i>	Quantity	Part #
	2" complete meter assembly (parts 1 to 6)	1	05060117
	1.5" complete meter assembly (parts 1 to 6)	1	05060119
1	2.0" NPT Outlet	1	
	1.5" NPT Outlet	1	
2	Turbine shaft	1	
3	O ring 56.52x5.33	1	
4	Turbine Assembly	1	
5	Turbine Nozzle	1	
6	Snap clip Φ 52	1	
7	Turbine meter cable	1	05060122

Circuit Boards, Controllers & Cables

Section 10.3.6

- All circuit board connections are color coded.

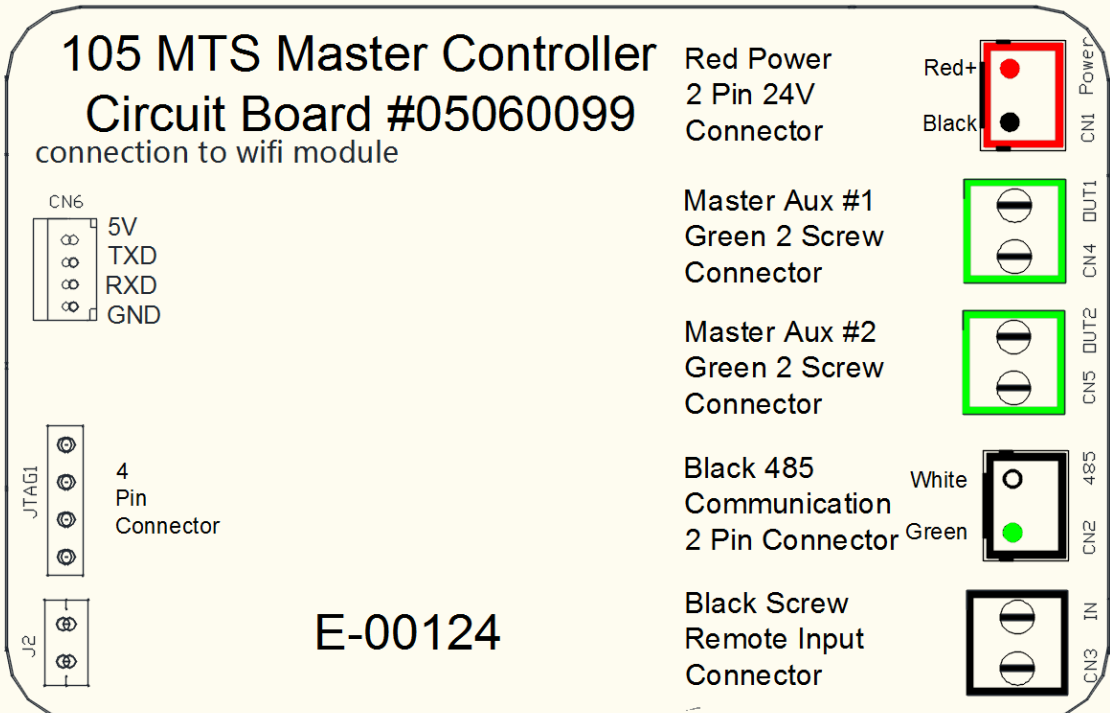
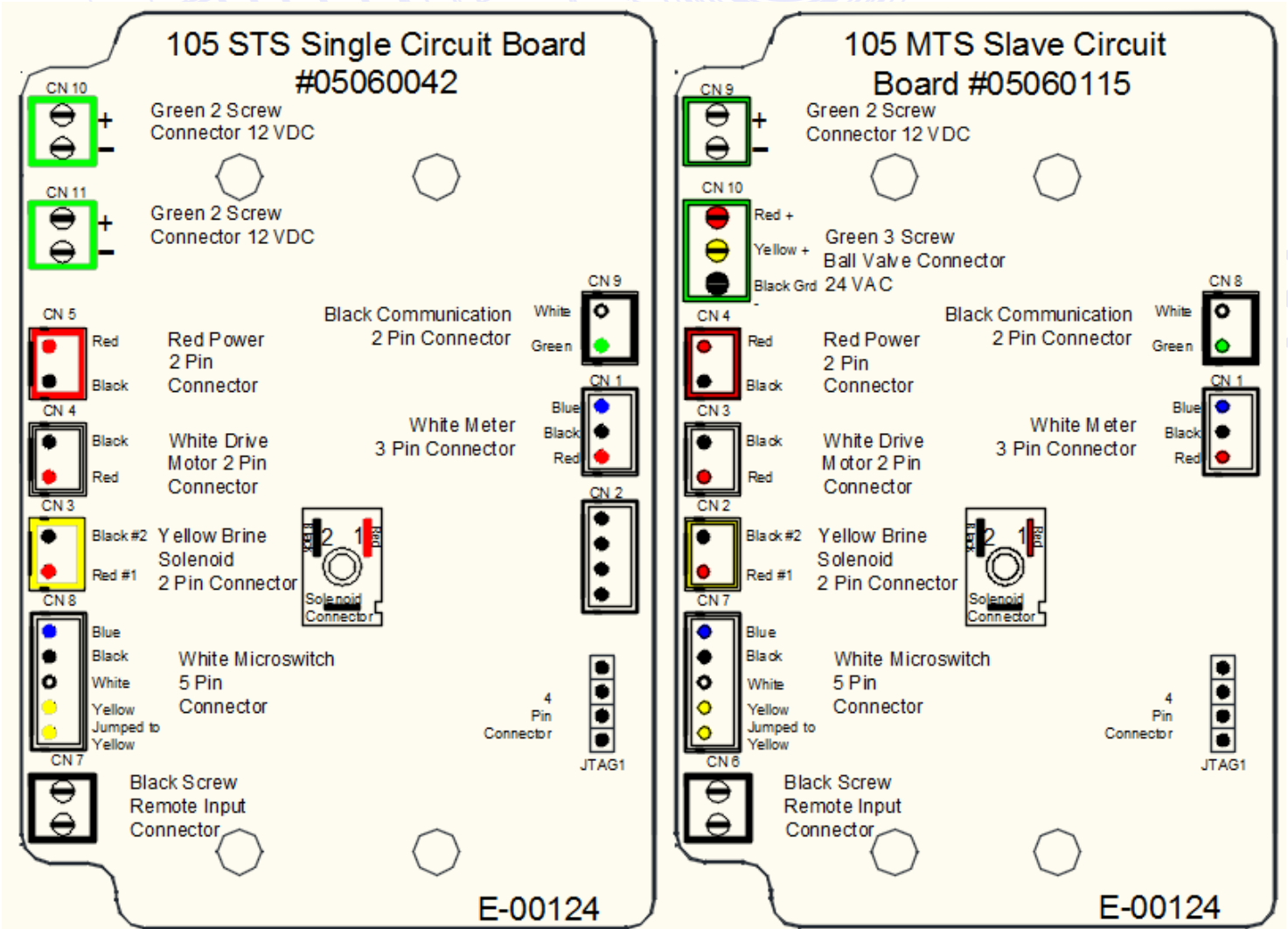

Circuit Boards, Controllers & Cables

Section 10.3.6

Controllers, Circuit Boards and Cables		
10010130	MTSB 105 Controller c/w Transformer & One Communication Cable	
-	MTSB 105 Controller Circuit Board (PCB)Use above	
05060115	105 Slave Valve Circuit Board (PCB)	
05060042	105 STS Single Valve Circuit Board (PCB)	
05060122	Cable, Meter to 105 Circuit	Board
05060121	Cable, Motor, 105 Valve 2W	Red Black w White Clip
05060123	Cable, Micro switch 105	Harness 4 wire
05060120	Cable, Solenoid, 105 2Wire	Harness RedBlack-YellowC
70011496 *	Connector, Only 4Pin Female	No Wire
12100064 *	Cable, Power Connection 105	Valve Black & Red 2 Wire
12100064B *	Cable, Communication 105	White Green B Clip 2Wire
60010197-1	Cable, Communication 105	4Pin Male-118" Long
11040071	Transformer MTS/ STS	24 VDC 3 Amp
05060154	Connector, MTS, 2 Pin Male To Transformer	
02170281	Harness, Wiring, MTS Controller	2pin & 4 pin
97000988	Cable, 3 Pin Female with wire #1Brown (red), #2Black, #3Blue(white)	
*	4 pin to circuit board connector use 02170281 & remove the 2 pin connector. Or use	

105 Part Numbers.xlsx

Media

Section 10.4

- Replacement media bed part numbers.
- Beds are complete with support bed gravel.
- For media break down and media loading instructions, see section 5.

REPLACEMENT MEDIA BEDS PART NUMBERS						
Tank Di- ameter	Multi Me- dia(0)	Activated Carbon (4)	Greensand (5)	Chem Free (6)	Birm (8)	Nextsand (9)
14	P450014	P450414	P450514	P450614	P450814	P450914
16	P450016	P450416	P450516	P450616	P450816	P450916
18	P450018	P450418	P450518	P450618	P450818	P450918
21	P450021	P450421	P450521	P450621	P450821	P450921
24	P450024	P450424	P450524	P450624	P450824	P450924
30	P450030	P450430	P450530	P450630	P450830	
36		P450436	P450536	P450636	P450836	

Other Components

Section 10.5

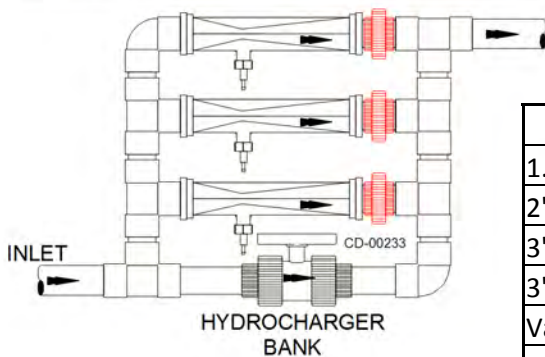

Standard Hydrocharger Banks	
1.5" inlet, 1.5" bypass valve-1 air inductor	P151501
2" inlet, 1.5" bypass valve-3 air inductors	P201503
3" inlet-2" bypass valve -2 Air inductors (K)	M302002-K
3" inlet-2" bypass valve -3 Air inductors (L)	M302003-L
Vacuum breaker 1.5"MNPT	310527
Air release valve Brakmaun	50701
Valve Vacuum breaker 1" mnpt	3105271
Chemical feeder 45MHP2-120V	11873/11809
50 gallon graduated chemical tank	40380

DND parts for Manual.xlsx

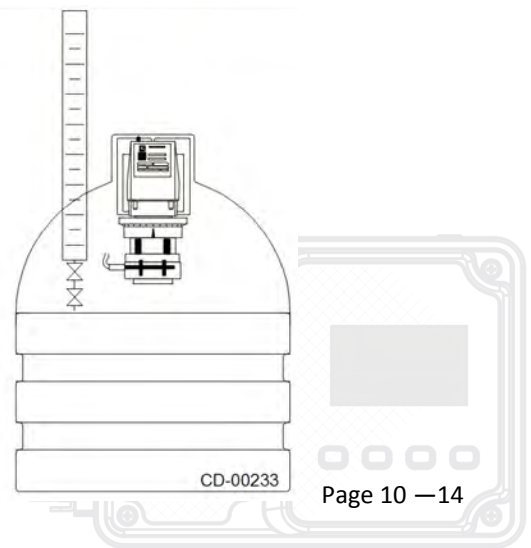

1. Unit fails to initiate a regeneration cycle.	A. No power supply. B. Meter cable defective or not inserted or meter stuck C. Defective circuit board.	A. Check electrical service, fuse, etc. B. Check and replace the impeller or the meter cable. C. Replace the circuit board.
2. Outlet water is untreated.	A. By-pass valve open. B. Leak between valve and central tube. C. Internal valve leak.	A. Close by-pass valve B. Check if central tube is cracked or O-ring is damaged. Replace faulty parts. C. Replace seals, spacers and piston assembly.
3. High pressure drop.	A. Iron or scale build up in raw water feed line. B. Unit not regenerating properly. C. Unit not regenerating frequent enough	A. Clean piping B. Check backwash flowrate to ensure unit backwashing at the correct rate. Check DLFC & measure flowrate. C. Increase regeneration frequency.
4. Media in the drain / drain line	A. Air in the system. B. Incorrect drain line flow control.	A. Check system for proper air release. B. Check for proper DFLLC button.
5. Media in the service line.	A. Distribution tube not plugged when loading media. B. Broken or cracked internal distribution.	A. Clean or replace distribution. B. Replace distribution
6. Valve motor runs continuously.	A. Micro switch faulty. B. Defective circuit board.	A. Replace micro switch. B. Replace circuit board.
7. Water running to drain when in service.	A. Foreign matter in valve head . B. Internal leak. C. Drive gear of power head got stuck D. Defective circuit board	A. Remove piston assembly & remove foreign material. B. Replace seals, spacers and piston assembly. C. Check, clean or replace the drive gear assembly. D. Replace circuit board.

105 modified-troubleshooting.xlsx.

PCB Trouble shooting :

At "Main display" page, inactivated Gray color of the Tank icon caused by a bad communication cables or connection or wrong slave valve setup.

Alarm page and beeping as right:

E1: Check the micro switch cable or harness connection to PCB then plug power on again.

E2: Check all include slave PCB/ wire/motor and valve piston movement which can cause failure of positioning.



**Tank 3#
Error E2 Alarm !**

E1: The harness of micro switch is not plugged or loose when Power tum on.
E2: Motor can't find right position in 10 mins

Press Any key to Exit

Commercial Softener & Filter Unit Warranty

Products manufactured by Canature WaterGroup™ are warranted to be free from defects in materials and workmanship where properly installed, operated and maintained. The length of the product warranties vary as per below

WARRANTY TABLE FOR ASSEMBLED UNITS

Fiberglass tanks 14”-63” in diameter or larger	5Years**
Control Valves & Electronics	5 Years*
Diaphragm Valves, Meters & Electric Ball Valves	1 Year
Brine Tanks And Internal Assemblies	1 Year*
Media	Limited to warranty provided by original manufacturer
Vinylester / Hot Water Application* Max Temp 150F	1 Year
Steel Tanks (epoxy lined)	1Year
All other components +	1 Year ***
*** Components not manufactured by Canature Watergroup are limited to the warranty given by the manufacturer of the component	

*** Warranty on Control Valve and Parts**

Canature WaterGroup™ will replace any part (except for wear and tear items – media, piston, seals and brine valve) which fails within the time period specified in the chart above from date of manufacture, as indicated by the serial number, provided the failure is due to a defect in material or workmanship. The only exception shall be when proof of purchase or installation is provided and then the warranty period shall be from the date thereof.

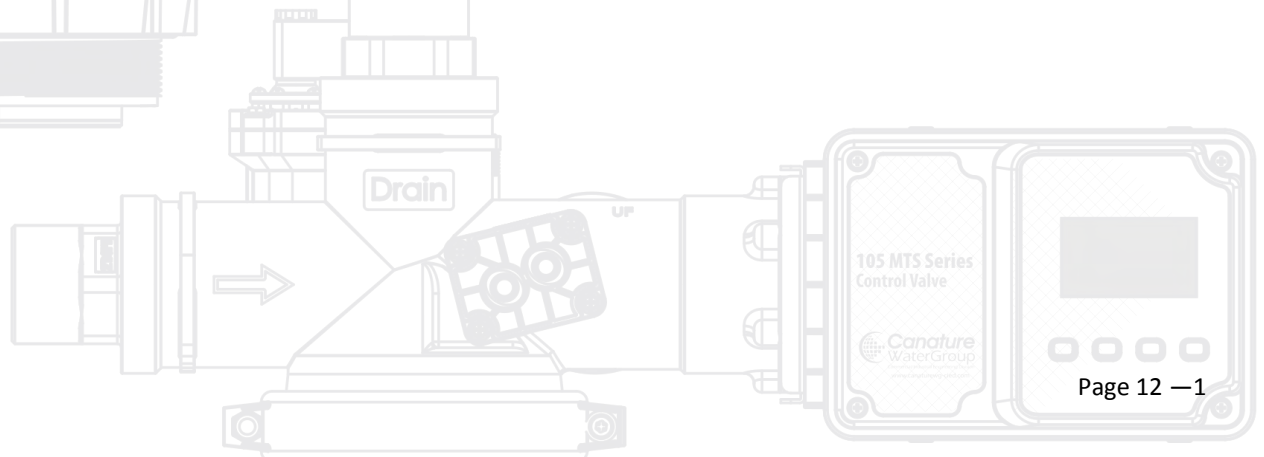

****Warranty on Mineral Tanks and Brine Tanks:**

Canature WaterGroup™ will provide a replacement mineral tank or brine tank to any original equipment purchaser in possession of a tank that fails within the time outline in the chart above, provided that the system is at all times operated in accordance with specifications and not subject to freezing or vacuum.

**On fiberglass tanks 24" diameter or larger, due to slight expansion and contraction of the tanks, flexible connectors must have been properly installed between the tank openings and rigid piping. Also a vacuum breaker(s) must have been properly installed to protect the tank from vacuum under all conditions. Failure to install flex connectors and/or vacuum breaker(s), or improper installation the tank warranty will be void.

In addition, if the fiberglass tank has a tripod base, it must have been properly and securely attached to the floor. If not done or improperly installed, the tank warranty will be void.

General Provisions:

Damage to any part of this commercial system as a result of misuse, misapplication, neglect, alteration, accident, installation or operation contrary to our printed instructions, damage to ion exchange resin and seals caused by chlorine / chloramines in the water supply, damage to internal pistons and seals caused by wear and tear from iron, manganese, sediment and or silt, or damage caused by any force of nature is not covered in this warranty. We will repair or replace defective parts if our warranty department determines it to be defective under the terms of this warranty. Canature WaterGroup™ assumes no responsibility for consequential damage, labor or expense incurred as a result of a defect or failure. Media and Resin coverage is limited to the warranty provided by the original manufacturer.

Return of Goods:

An authorization number must be obtained before returning any merchandise. NOTE: All material returned to Canature WaterGroup™ must be returned freight prepaid. Upon inspection, if our warranty department determines the goods to be defective under the terms of this warranty, the warranty shall be limited to the defective parts to be repaired, replaced, or credited at Canature WaterGroup's™ discretion. You pay only freight to return defective parts to our factory and local dealer charges, including but not limited to labor charges, travel and transportation expenses, and handling fees.

Some State & Provincial jurisdictions do not allow limitations on how long an implied warranty lasts, so the above limitation may not apply to you. Similarly, some State & Provincial jurisdictions do not allow exclusion of incidental or consequential damages, so the above limitations or exclusions may not apply to you. This warranty gives you specific legal rights, and you may also have other rights, which vary from jurisdiction to jurisdiction. Consult your authorized Dealer for warranty and service information.

U.S.A.
9760 Mayflower Park Dr.
Suite 110, Carmel, IN 46032



U.S.A.
56 Lightcap Rd.
Pottstown, PA 19464



U.S.A.
4645 W. McDowell Rd.
Suite 106 Phoenix, AZ 85035



Canada West
855 Park St. Unit 1
Regina, SK S4N 6M1



Canada East
490 Pinebush Rd. Unit 1
Cambridge ON N1T 0A5



TOLL FREE:1-877-288-9888

