

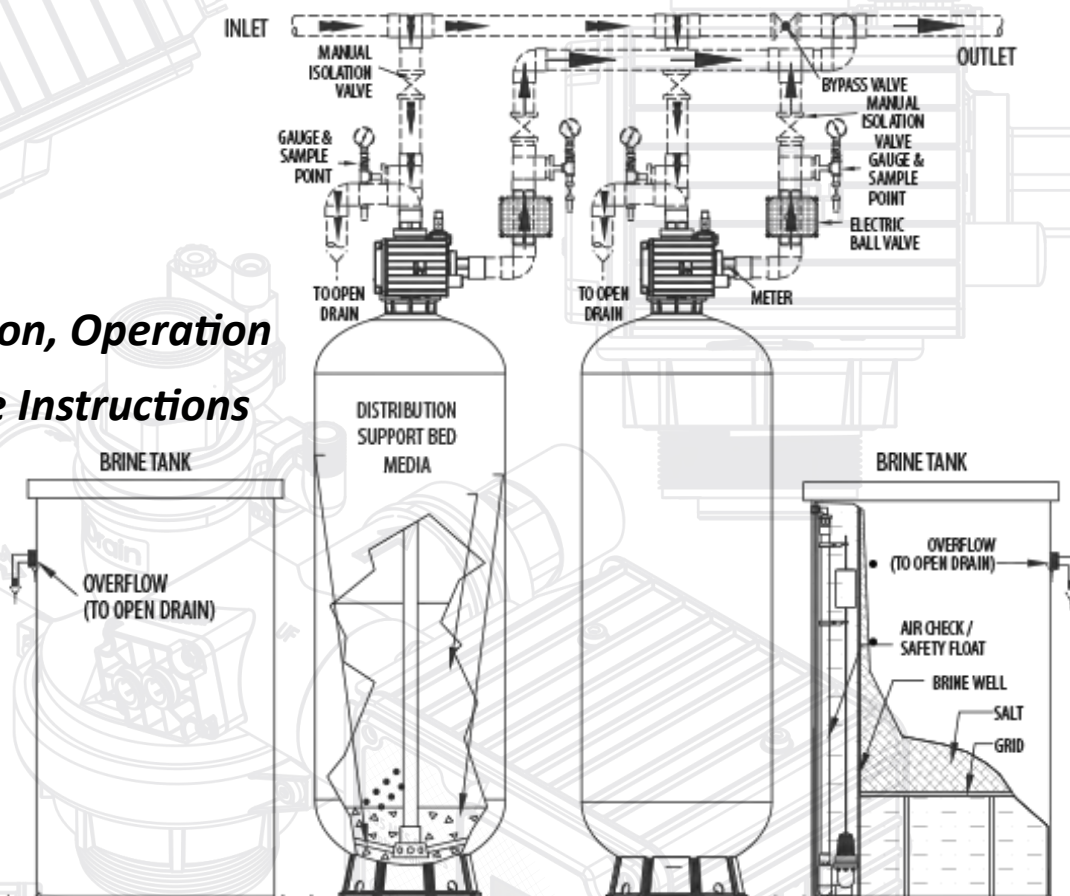

Commercial/Industrial Engineering Division

# 105 Series MTS Softeners

## Installation, Operation & Service Instructions



- ◆ Please read carefully all instructions before proceeding with the installation. Systems must be properly installed, operated and maintained. Failure to do so voids the warranty.
- ◆ On fiberglass tanks, due to slight expansion and contraction of the tanks, flexible connectors must have been properly installed between the tank openings and rigid piping. Also a vacuum breaker(s) must have been properly installed to protect the tank from vacuum under all conditions. Failure to install flex connectors and/or vacuum breaker(s), or improper installation will void tank warranty.
- ◆ The systems must be protected from freezing temperatures and avoid installing in direct sunlight.
- ◆ Do not use the system with water that is microbiologically unsafe or of unknown quality without adequate disinfection before or after the system.
- ◆ Test the water periodically to verify that the system is operating satisfactorily. A regular preventative maintenance inspection by a water professional is recommended.
- ◆ Handle all components with care. Do not drop, drag or turn components upside down.
- ◆ Check all local plumbing and electrical codes. The installation must conform to them.
- ◆ It is recommended to wait until the entire system is fully pressurized, confirmed to be operating properly, and recheck for leaks before leaving the site.

# OWNERS MANUAL

## Table Of Contents

### Section 1— Receiving

- 1.1 Receiving & inspection
- 1.2 Major component
- 1.3 Standard components
- 1.4 Optional components

### Section 2— Specifications

- 2.0 Unit parameters
- 2.1 Model legend
- 2.2 Regeneration cycles, DLFC & BLFC settings
- 2.3 Installation specifications
- 2.4 General specifications
- 2.5 Valve dimensions

### Section 3 - Planning location & installation

- 3.1 Location considerations
- 3.2 Materials required
- 3.3 Typical piping layout
- 3.4 Optional piping

### Section 4 - Installation

- 4.0 General installation guide
- 4.1 Tank positioning
- 4.2 General piping
- 4.3 Special applications piping
- 4.4 Control valve / MTS controller installation

### Section 5- Media Loading

- 5.0 General guidelines
- 5.1 Media descriptions
- 5.2 Media quantities

### Section 6- Start up

- 6.0 Information Required And Overview For Start-up
- 6.1 Programming parameters, calculating hardness
- 6.2 Controller programming quick guide for start-up
- 6.3 Piping inspection, media bed soak
- 6.4 System regeneration

### Section 7- Operation

- 7.0 Operating conditions
- 7.1-7.4 Cycle operation

### Section 8- Programming

- 8.0 MTS controller overview
- 8.1 Key pad configuration
- 8.2 MTS system types
- 8.3 System operation—main screens
- 8.4.0 Main menu settings
- 8.5 Information screens
- 8.6 Regeneration screens
- 8.7 Initiating a regeneration
- 8.8 PCB troubleshooting—error codes

### Section 9- General maintenance

- 9.0 Recommended tools
- 9.1 PCB / motor / power head removal
- 9.2 Seal / spacer (lantern ring) /piston replacement
- 9.3 Clean / replace injectors, DLFC, BLFC, meter
- 9.4 Installing o-rings

### Section 10—Repair Parts

- 10.1 -Mineral tanks/ closures
- 10.2 Distribution
- 10.3.0 Valve body parts breakdown
- 10.3.1 Brine valve injector assembly
- 10.3.2 Piston / seals / spacers (lantern ring)
- 10.3.4 Drain line flow control assembly DLFC
- 10.3.5 Outlet meter assembly
- 10.3.6 Circuit boards, cables, wiring harness
- 10.4 Media beds
- 10.5 Valve Internal Parts
- 10.6 Misc. parts
- 10.7 Brine tanks

### Section 11 -Troubleshooting

### Section 12 -Warranty

105 MTS Series  
Control Valve

Canature  
WaterGroup



## RECEIVING AND INSPECTION

## Section 1.1

Be sure to check the entire shipment for any shipping damage or lost parts. Note any damage to shipping cartons. All skids are fully shrink wrapped at the factory. Note if any skids are missing shrink wrap. If damage is present, notify the transport company immediately. The manufacturer is not responsible for damage or loss in transit.

Note: Do not discard any small parts. To avoid loss of small parts, keep them in the parts bag until you are ready to use them. Thoroughly check all boxes & cartons to ensure there are no small parts tucked inside.

### Major Components

### Section 1.2

*Note: all external piping, drain lines, isolation valves, sample points, etc., are supplied by others.*

This manual covers all duplex, triplex, and quadplex softener systems as well as the single softener when using the MTS controller. (This allows for system expansion later if desired).

Listed below are quantities for a SINGLE system. Note that all systems, no matter the size, use only one main MTS controller with a color display.

A duplex system will have twice the quantity of mineral tanks, media beds, tanks and distribution, control valves, brine tanks etc. A triplex system will have three times the quantity of mineral tanks, media beds, tanks and distribution, control valves, brine tanks.

-Each individual softener unit in the system will include one of the following:

-One electronic 105 control valve (Note any loose parts. If the system is a responsive flow softener system, one electric ball valve will be included for each 105 control valve.

-One fiberglass media tank complete with internal hub & lateral distribution. Please note the distribution may already be installed inside the tank. If the distribution has already been installed, it must be closely inspected to ensure it was not damaged in shipping. If the distribution is cracked or broken, it must be repaired before proceeding. (For more details see section 10.1 & 10.2)

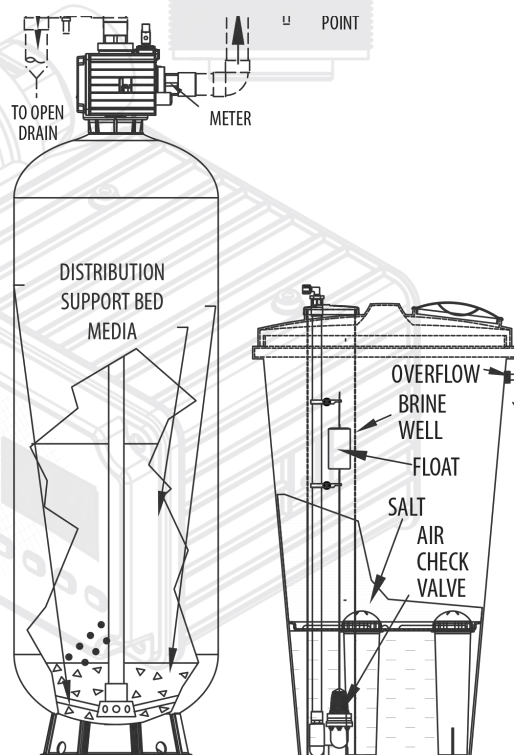

## Major Components

## Section 1.2

- One media bed (For more details and quantities see section 5)
- One brine tank assembly. (For more details see section 10.7)
- There may also be other **optional** items included such as flexible pipe connectors, vacuum release valves, etc., which are required for a proper installation.

Standard Unit Major Component Quantities						xlsx.D-00330 Weights Tables
Item	Single System	Duplex System	Triplex System	Quadplex System	Pentaplex System	
MTS Central Controller	1	1	1	1	1	
Control Valve	1	2	3	4	5	
Electric Ball Valve (if responsive flow system)	1	2	3	4	5	
Mineral Tank	1	2	3	4	5	
Distribution (May be installed in mineral tank)	1	2	3	4	5	
Media bed	1	2	3	4	5	
Brine Tank Assembly	1	2 *	3	4	5	
* If system duplex alternating, only one brine tank and a brine line tee is included)						



### Standard Components

### Section 1.3

Below are some of the main standard components that are included with the standard unit (media bed not shown).

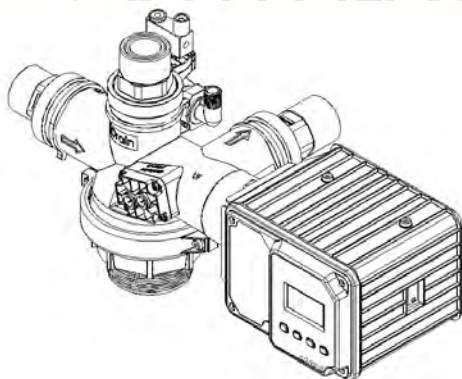

One MTSB central controller.

105 Control valves with internal injectors, drain line, brine line flow controls and meters.

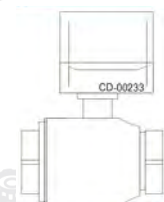

Demand recall softeners have one electric ball valve for each 105

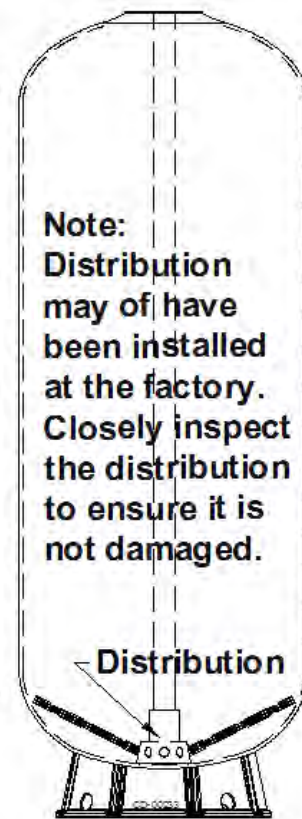
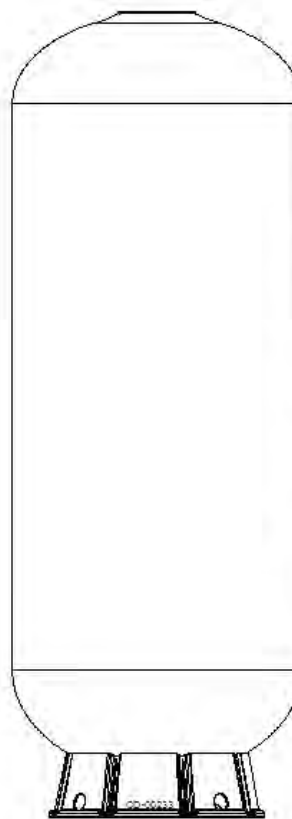

**Note:** Distribution may of have been installed at the factory. Closely inspect the distribution to ensure it is not damaged.

Distribution

Media tank showing internal hub and lateral distribution.

Note: due to the slight expansion and contraction of the media tank, the piping

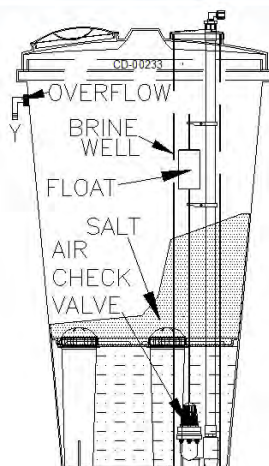
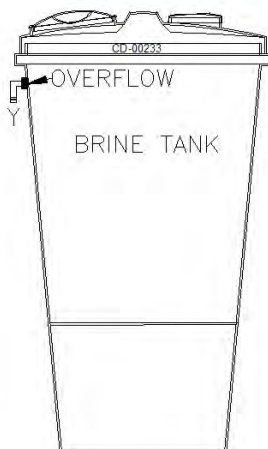

Brine tank complete with internal safety float and brine grid. For units up to and including 450,000 (15 ft<sup>3</sup>), brine line is also included. For all larger units, brine line is not included and is normally piped in 3/4" or 1" pvc.

### Optional Components

Below are some of the optional components that are available.

### Section 1.4

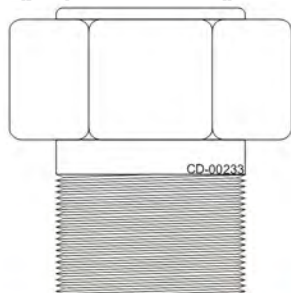

Vacuum breaker (installed on inlet line). Media tanks must be protected by from vacuum.

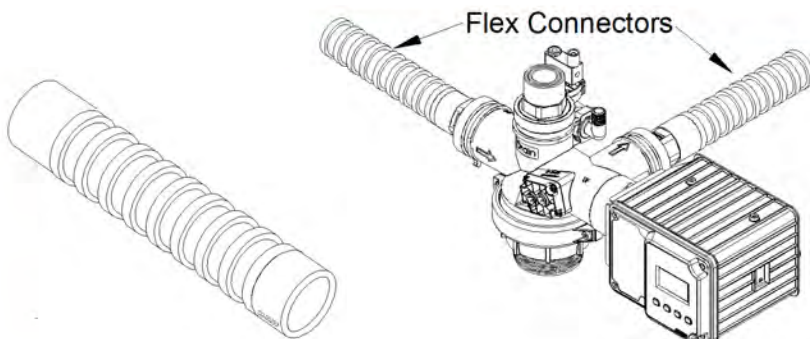

Flex connectors attach to the inlet and outlet of the control valve to allow some tank movement.

## Specifications

## Section 2.0

### Unit Parameters

- Recommended system operating pressure 30 to 100 psi (2 to 6.9 bar).
- Operating temperature 39<sup>0</sup> to 100<sup>0</sup> F (4<sup>0</sup> to 38<sup>0</sup> C).
- Electronic 105 control valve material. Plastic PPO (Noryl).
  - Maximum operating pressure 125 psi (8.6 bar).
  - 1.5" or 2" mnpt valve pipe connections.
  - Down flow regeneration.
  - Electrical rating 120 V / 60Hz input- 24V / 60Hz output.
  - Class 2 transformer.
- MTSB electronic main controller with color display.
- Mineral tanks. Corrosion resistant fiberglass reinforced polyethylene.
  - 24" diameter and below are NSF /ANSI 44.
  - 30" diameter and above are NSF/ ANSI 61.
  - Maximum vacuum : 127 Hg.
  - Maximum operating pressure 150 psi (10.3 bar).
- Ion exchange resin. High capacity IAPMO certified 8% Canature resin.
- Internal hub and lateral distribution.
- Brine tank. High density polyethylene c/w salt grid, brine well, safety float & overflow.

Model Legend

Section 2.1

# 105 MTS 150-2" Duplex Demand Softener

## Model: 105MTS 150-2"D8000

Valve Series	Softener Size	Valve Size	Number Of Tanks	System Type	Options Last 3 Digits
<b>105MTS -Multi tank unit</b> <i>c/w 105 series control &amp; MTS master controller</i> <b>1.5" or 2"</b>	90	1.5"	S - Single	5-Parallel flow 1 meter per valve	0-Standard
	120	Standard On 90 & 120	D-Duplex	6-Parallel flow 1 System meter Series regeneration	L-Lockout contact
	150		T-Triplex		R-Non-standard resin
	180	2"	Q-Quadplex	8-Responsive flow 1 meter per valve	S-Side mount
	210	P-Pentaplex			T-Treated water regeneration
	240				
	270			9-Alternating 1 meter per valve	
	300				
	360				
	390				
450					

105 modified.xlsx



**Regeneration Cycles, DLFC and BLFC Settings**

**Section 2.2**

105 Down Flow Softeners									
Softener Model	DLFC	BLFC	Salting Level (lbs/ft <sup>3</sup> )	Salt Usage (lbs)	Injector Downflow	BW (min)	Brine Draw	Fast Rinse	Refill
90	5+	0.95	6	18	Black N & T 4S	9	40	9	7
	5+	0.95	10	30	Black N & T 4S	9	56	9	11
	5+	0.95	15	45	Black Nozzle Orange Throat	9	70	9	16
120	7+	0.95	6	24	Black Nozzle Orange Throat	9	40	9	9
	7+	0.95	10	40	Black Nozzle Orange Throat	9	62	9	14
	7+	0.95	15	60	Gray #1	9	68	9	21
150	9.5+	0.95	6	30	Black Nozzle Orange Throat	9	47	9	11
	9.5+	0.95	10	50	Black Nozzle Orange Throat	9	78	9	17
	9.5+	0.95	15	75	Gray	9	84	9	27
180	12 (#5)	0.95	6	36	Black Nozzle Orange Throat	9	56	9	13
	12 (#5)	0.95	10	60	Gray	9	68	9	22
	12 (#5)	0.95	15	90	Gray	9	101	9	32
210	12 (#5)	0.95	6	42	Black Nozzle Orange Throat	9	65	9	15
	12 (#5)	2	10	70	Purple	9	70	9	12
	12 (#5)	2	15	105	Red	9	84	9	18
240	15 (#6)	0.95	6	48	Gray	9	55	9	17
	15 (#6)	2	10	80	Purple	9	65	9	14
	15 (#6)	2	15	120	White	9	92	9	20
270	15 (#6)	0.95	6	54	Gray	9	61	9	19
	15 (#6)	2	10	90	White	9	69	9	15
	15 (#6)	2	15	135	White	9	103	9	23
300	15 (#6)	2	6	60	Purple	9	60	9	10
	15 (#6)	2	10	100	White	9	77	9	17
	15 (#6)	2	15	150	White	9	115	9	25

Cone Buttons #4=8gpm #5=12 gpm #6=15 gpm #7=20 gpm + Flat Buttons

105 modified .xlsx.

Note: Fill performance is sensitive to the combination BLFC and injector size. See Section 10.3.4

105 MTS Series Control Valve

Canature WaterGroup

105 Down Flow Softeners									
Softener Model	DLFC	BLFC	Salting Level (lbs/ft <sup>3</sup> )	Salt Usage (lbs)	Injector Downflow	BW (min)	Brine Draw	Fast Rinse	Refill
360	24 (#5x2)	2	6	72	White	9	55	9	12
	24 (#5x2)	2	10	120	White	9	92	9	20
	24 (#5x2)	2	15	180	White	9	138	9	30
390	24 (#5x2)	2	6	78	White	9	60	9	13
	24 (#5x2)	2	10	130	White	9	100	9	22
	24 (#5x2)	2	15	195	White	9	149	9	33
450	24 (#5x2)	2	6	90	White	9	69	9	15
	24 (#5x2)	2	10	150	White	9	115	9	25
	24 (#5x2)	2	15	225	White	9	172	9	38

Cone Buttons #4=8gpm #5=12 gpm #6=15 gpm #7=20 gpm + Flat Buttons

105 modified .xlsx.

Note: Fill performance is sensitive to the combination BLFC and injector

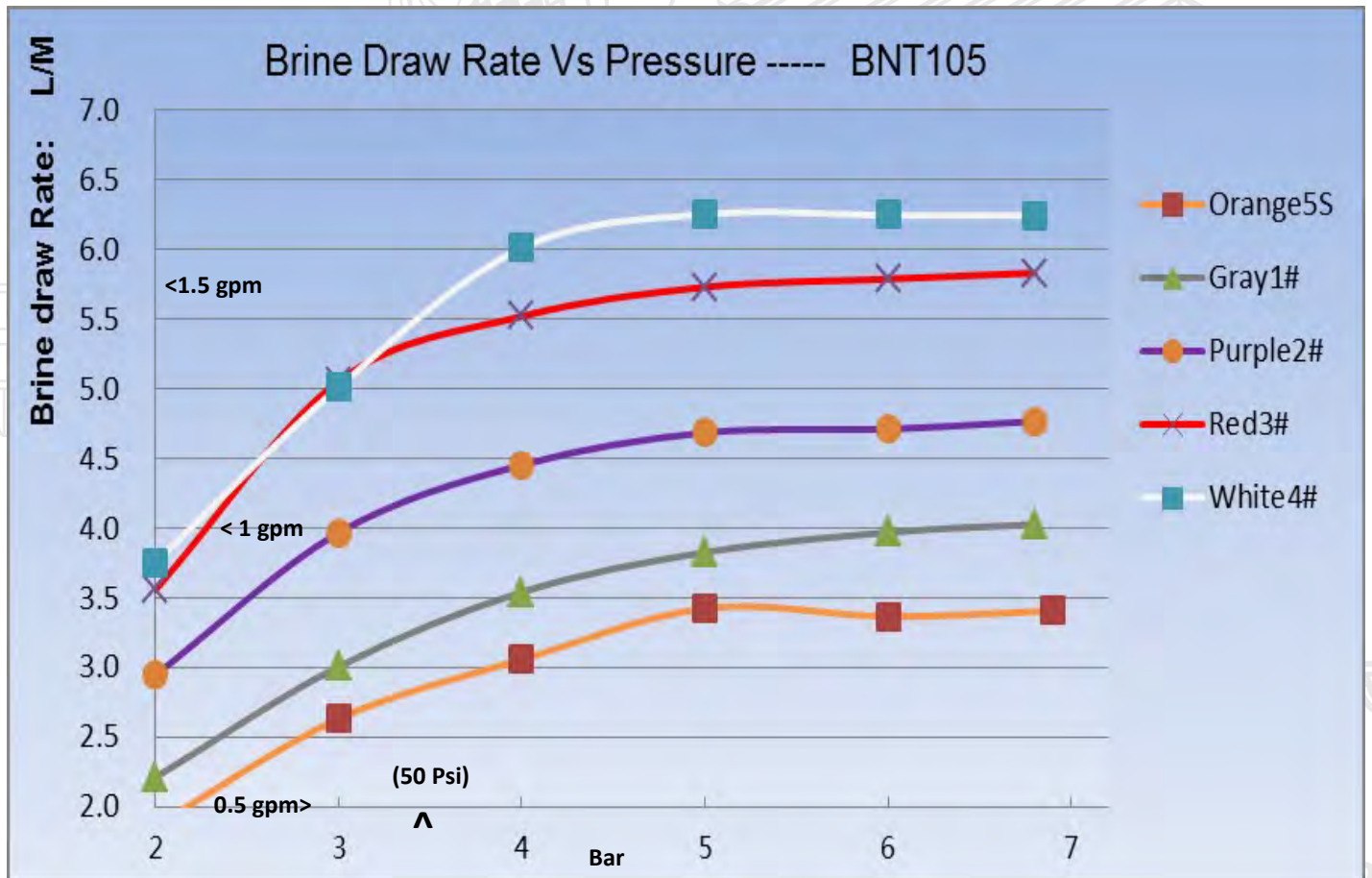

General Specifications

Installation Space

Section 2.3

Model	Dimensions		Installation			Duplex	Triplex	Quadplex
	Mineral Tank	Brine Tank	Height	Depth	width	width	width	width
	in	in	in	in	in	in	in	in
	mm	mm	mm	mm	mm	mm	mm	mm
105MTS 90 - 1.5"	14 x 65 356 x 1651	24 x 37 610 x 940	86 2,184	37 940	47 1,194	94 2388	141 3581	188 4775
105MTS 120 - 1.5"	16 x 65 403 x 1651	24 x 37 610 x 940	88 2,235	37 940	49 1,245	98 2489	147 3734	196 4978
105MTS 150 - 2"	18 x 65 475 x 1651	24 x 37 610 x 940	88 2,235	37 940	51 1,295	102 2591	153 3886	204 5182
105MTS 180 - 2"	21 x 62 533 x 1575	29 x 50 740 x 1275	88 2,235	40 1,016	59 1,499	118 2997	177 4496	236 5994
105MTS 210 - 2"	21 x 62 533 x 1575	29 x 50 740 x 1275	88 2,235	40 1,016	59 1,499	118 2997	177 4496	236 5994
105MTS 240 - 2"	24 x 72 610 x 1829	33 x 53 840 x 1335	96 2,438	42 1,067	66 1,676	132 3353	198 5029	264 6706
105MTS 270 - 2"	24 x 72 610 x 1829	33 x 53 840 x 1335	96 2,438	42 1,067	66 1,676	132 3353	198 5029	264 6706
105MTS 300 - 2"	24 x 72 610 x 1829	33 x 53 840 x 1335	96 2,438	42 1,067	66 1,676	132 3353	198 5029	264 6706
105MTS 360 - 2"	30 x 72 762 x 1829	33 x 53 840 x 1335	107 2,718	42 1,067	72 1,829	144 3658	216 5486	288 7315
105MTS 390 - 2"	30 x 72 762 x 1829	38 x 55 965 x 1397	107 2,718	46 1,168	77 1,956	154 3912	231 5867	308 7823
105MTS 450 - 2"	30 x 72 762 x 1829	38 x 55 965 x 1397	107 2,718	46 1,168	77 1,956	154 3912	231 5867	308 7823

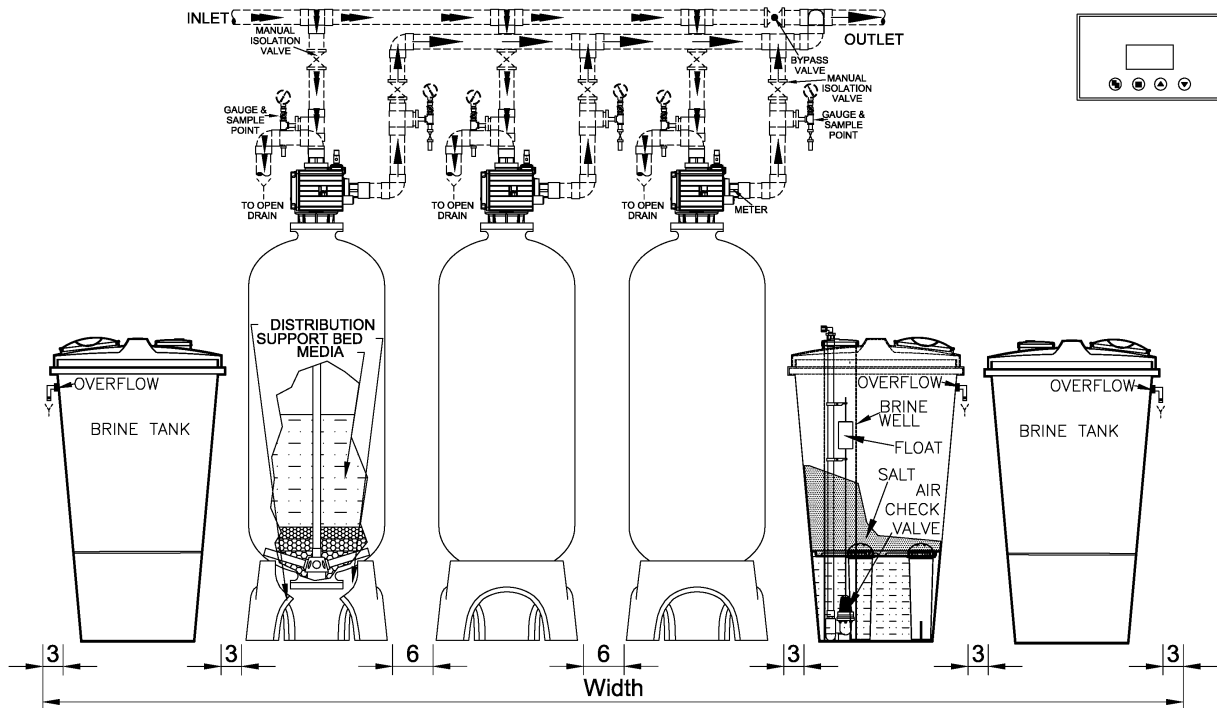



**General Specifications**

**Section 2.4**

Model	Flow Rates per Tank								
	Capacity	Resin	Critical	105 - 1.5"/2"			Max Flow	Dimensions	
	@15 lbs/Ft <sup>3</sup>	Ft <sup>3</sup>	Flow	@ 15 PSI	@ 25 PSI	To Drain	Mineral Tank	Brine Tank	
	@10 lbs/Ft <sup>3</sup>	M <sup>3</sup>	USGPM	USGPM	USGPM	USGPM	in	in	
		l/s	l/s	l/s	l/s	mm	mm		
<b>MTS 90</b>	90,000	3	15	32	45	5	14 x 65	24 x 37	
	81,000	0.08	0.95	2.02	2.84	0.32	356 x 1651	610 x 940	
<b>MTS 120</b>	120,000	4	20	36	51	7	16 x 65	24 x 37	
	108,000	0.11	1.26	2.27	3.21	0.44	403 x 1651	610 x 940	
<b>MTS 150</b>	150,000	5	25	46	62	9	18 x 65	24 x 37	
	135,000	0.14	1.58	2.90	3.91	0.57	475 x 1651	610 x 940	
<b>MTS 180</b>	180,000	6	30	45	60	12	21 x 62	29 x 50	
	162,000	0.17	1.89	2.84	3.78	0.76	533 x 1575	740 x 1275	
<b>MTS 210</b>	210,000	7	35	43	59	12	21 x 62	29 x 50	
	189,000	0.20	2.21	2.00	3.72	0.76	533 x 1575	740 x 1275	
<b>MTS 240</b>	240,000	8	40	43	59	15	24 x 72	33 x 53	
	189,000	0.27	2.52	2.71	3.72	0.95	610 x 1829	840 x 1335	
<b>MTS 270</b>	270,000	9	45	46	62	15	24 x 72	33 x 53	
	243,000	0.25	2.84	2.90	3.91	0.95	610 x 1829	840 x 1335	
<b>MTS 300</b>	300,000	10	50	45	61	15	24 x 72	33 x 53	
	270,000	0.28	3.15	2.84	3.84	0.95	610 x 1829	840 x 1335	
<b>MTS 360</b>	360,000	12	60	50	66	25	30 x 72	30 x 50	
	324,000	0.34	3.79	3.15	4.16	1.58	762 x 1829	762 x 1270	
<b>MTS 390</b>	390,000	13	65	50	66	25	30 x 72	30 x 50	
	351,000	0.37	4.10	3.15	4.16	1.58	762 x 1829	762 x 1270	
<b>MTS 450</b>	450,000	15	75	49	64	25	30 x 72	36 x 48	
	405,000	0.42	4.73	3.09	4.03	1.58	762 x 1829	914 x 1220	

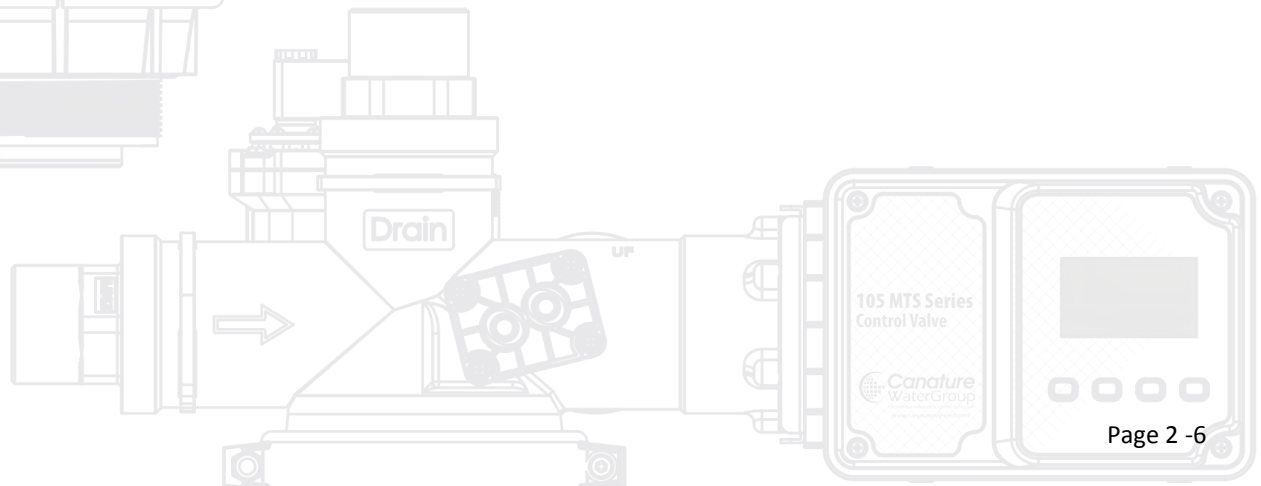

**105 Valve Dimensions**

**Section 2.5**

24.6" (625mm)

13.0"  
(331mm)

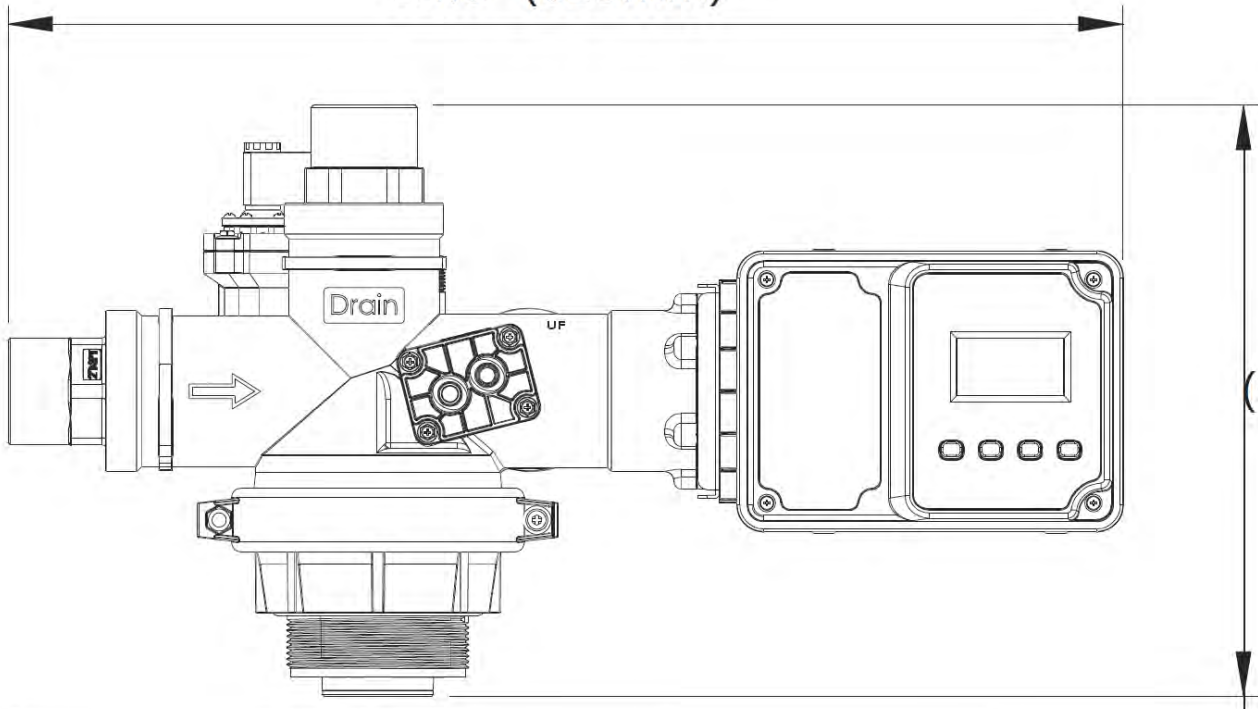

12.0" (303mm)

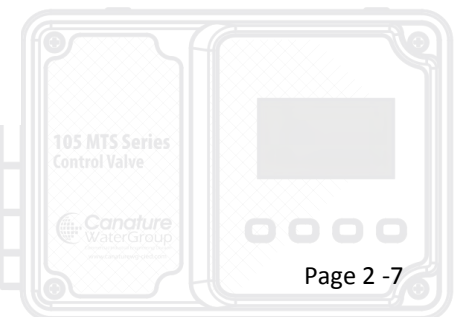
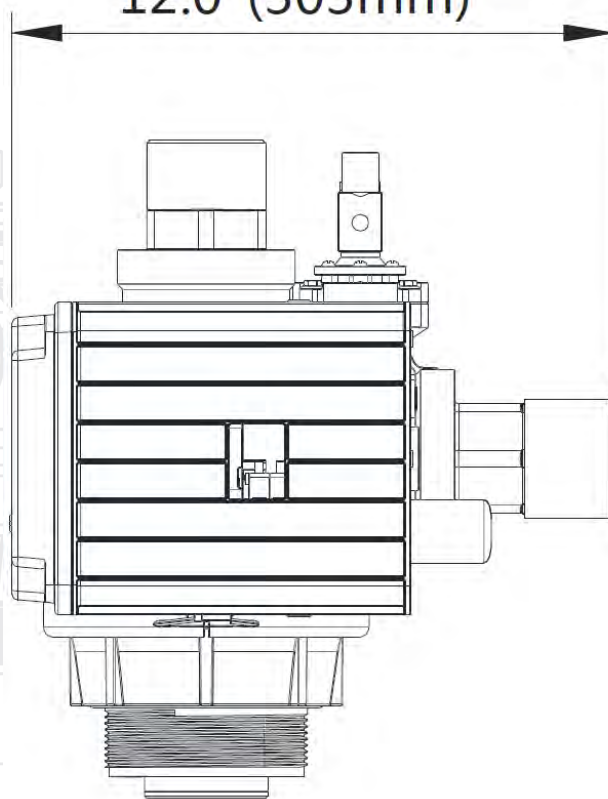

**PLANS FOR LOCATION AND INSTALLATION DIAGRAMS OF SYSTEM****Section 3.1**

- **WATER SUPPLY:** The system requires a potable water supply that will provide a continuous flow to meet regeneration flow specifications. A minimum pressure of 30 psi is required at the conditioner inlet. It is suggested that a Y type strainer be installed on the outlet of the system to prevent media getting out into the system should a distribution be compromised.
- **BOTH HOT AND COLD WATER CONDITIONING:** Connect the system to the water supply pipe, immediately *after* (downstream) the municipal supply water meter or well supply pressure tank. To provide *unconditioned* water to isolated faucets, if desired, run separate pipes from the water supply before the conditioner.
- **CONDITIONING HOT WATER ONLY:** Connect the system to the water supply pipe *before* (upstream) the water heater.

**CAUTIONS:**

- **Do not install** the conditioner **after**, or downstream from **the water heater. Hot water will damage** inner parts of the system, and may cause the loss of the water conditioner mineral bed. This will void the system warranty.
- **To reduce the risk of hot water backing-up**, into the conditioner, piping between the conditioner and water heater should be as long as possible. A backflow preventer or check valve is also recommended between the conditioner and the hot water heater.
- **DRAIN:** An open drain is needed nearby the conditioner, capable of carrying away backwash water at the rate of flow listed in the specifications. An open floor drain is preferred. Other approved open drain points are acceptable, if they do not cause a back-pressure on the conditioner drain pipe or hose. An open floor drain is also required for the overflow on the salt tank. All drain connections **MUST** have a proper air gap.
- **ELECTRICAL:** The system works on **24 AC volts only**. A direct plug-in transformer is included to reduce 120 V-60 Hz electrical power to 24 volts. An approved, grounded outlet is needed within 5' of the conditioner controller. The conditioner includes a 5' power cable to connect between the transformer and the controller. Surge protectors are recommended.
- **SPACE REQUIREMENTS:** Be sure to allow sufficient area around the media tanks, brine tanks for refilling with salt and other service that may be required. Minimum floor space and other dimensions are shown in section 2.



## Planning Location For Installation.

## Section 3.2

### MATERIALS YOU MAY NEED

- Use the drawings in section 3.3 as a guide for the materials required for the installation. The drawings show typical piping diagrams. All interconnecting piping, isolation & bypass valves, sample points / pressure gauges, etc. are not supplied with the unit.
- If the interconnecting piping is rigid, flex connectors will be required on all connections to the media tank as some movement is required. A flex connection may also be required on the drain line as well if the piping is rigid. The standard systems do not include flex connectors but can be supplied as optional items with the system.
- A vacuum breaker is recommended on the inlet of each media tank. The standard systems do not include vacuum breakers but can be supplied as optional items with the system.
- Note: Due to slight expansion and contraction of the media tanks, the piping must be designed to allow some movement as well as protection from vacuum, flex connectors and a vacuum breakers may be required. Failure to install or improperly install them will void the warranty. See drawing below.**
- To assist in servicing the control valve, place unions or flanges on the piping connections to the control valve.
- Install unit isolation and system bypass valves. These valves allow you to turn off water to individual units in the system, for servicing. The full-line bypass will allow water to service if the system is taken offline for service.
- Inlet and outlet sample points and pressure gauges are required to confirm proper operation of the system.
- **Minimum inside diameter** hose or pipe is required for the conditioner valve drain (see section 4). The drain connection at the valve is 1.5" or 2" male pipe thread. Also, on softeners, a length of 5/8" hose is needed for the drain overflow on brine tanks.

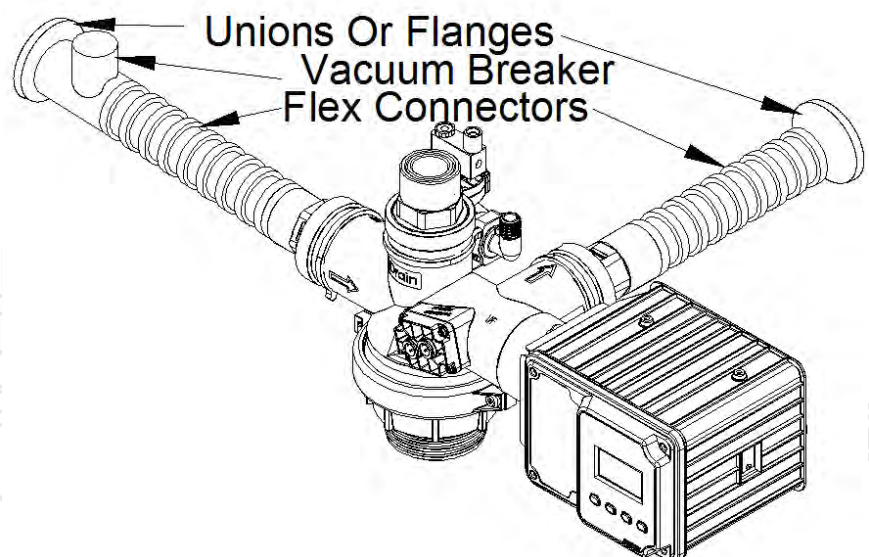

**Typical Softener Piping Layout Detail.**

**Section 3.3**

- All softener systems are no raw water bypass during regeneration with the exception of the single softener.
- The standard single softener is raw water bypass during regeneration with no raw water bypass available as an option.
- All standard softener systems use raw water for regeneration.
- The diagram shown shows the typical piping for a softener unit. Please note that the location for flex connectors (if required) is marked with a “#” and the vacuum breaker marked with a “ \* ”.

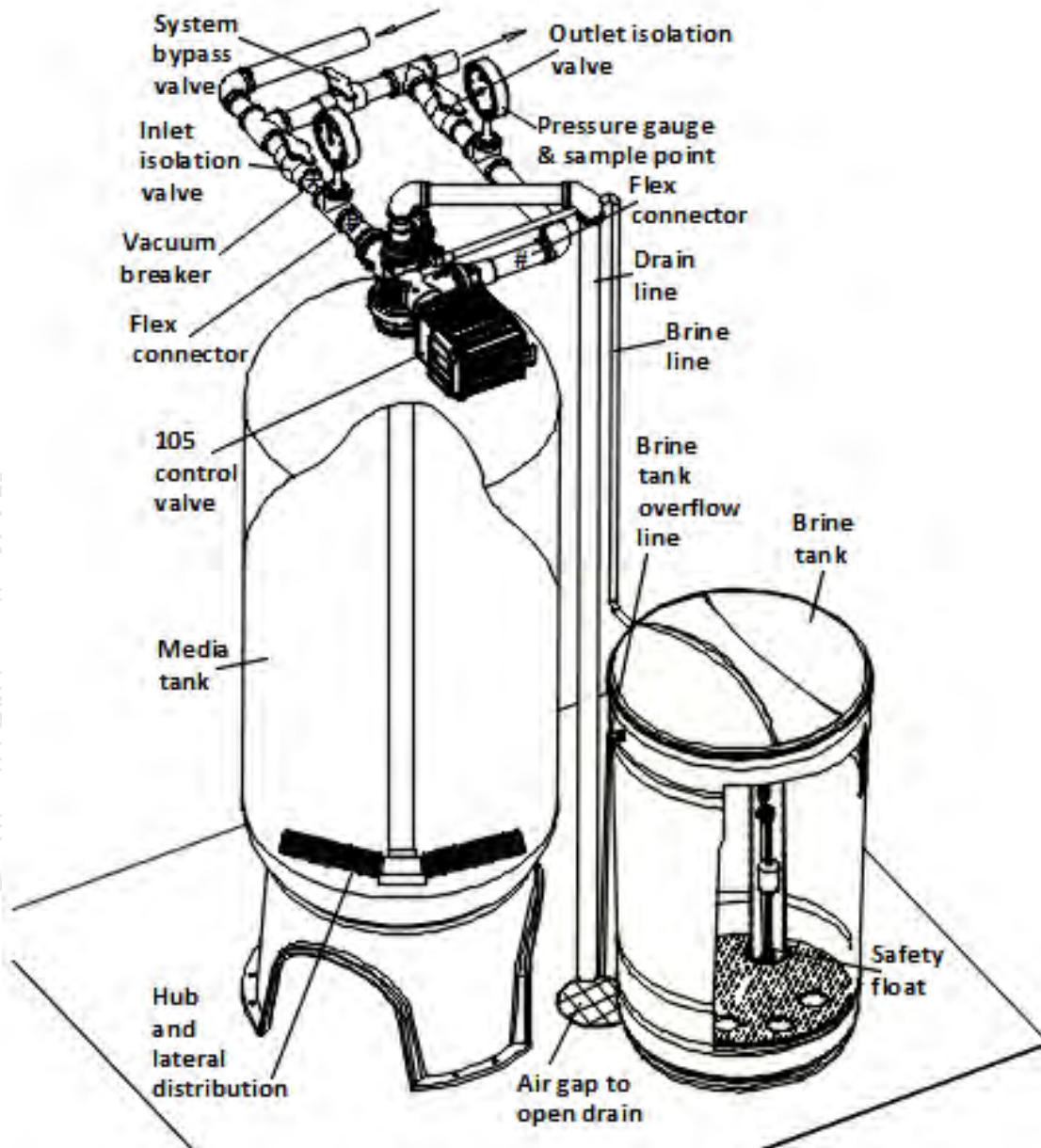

Typical Piping STS or MTS Single Softener. No Raw Water Bypass.

Section 3.3

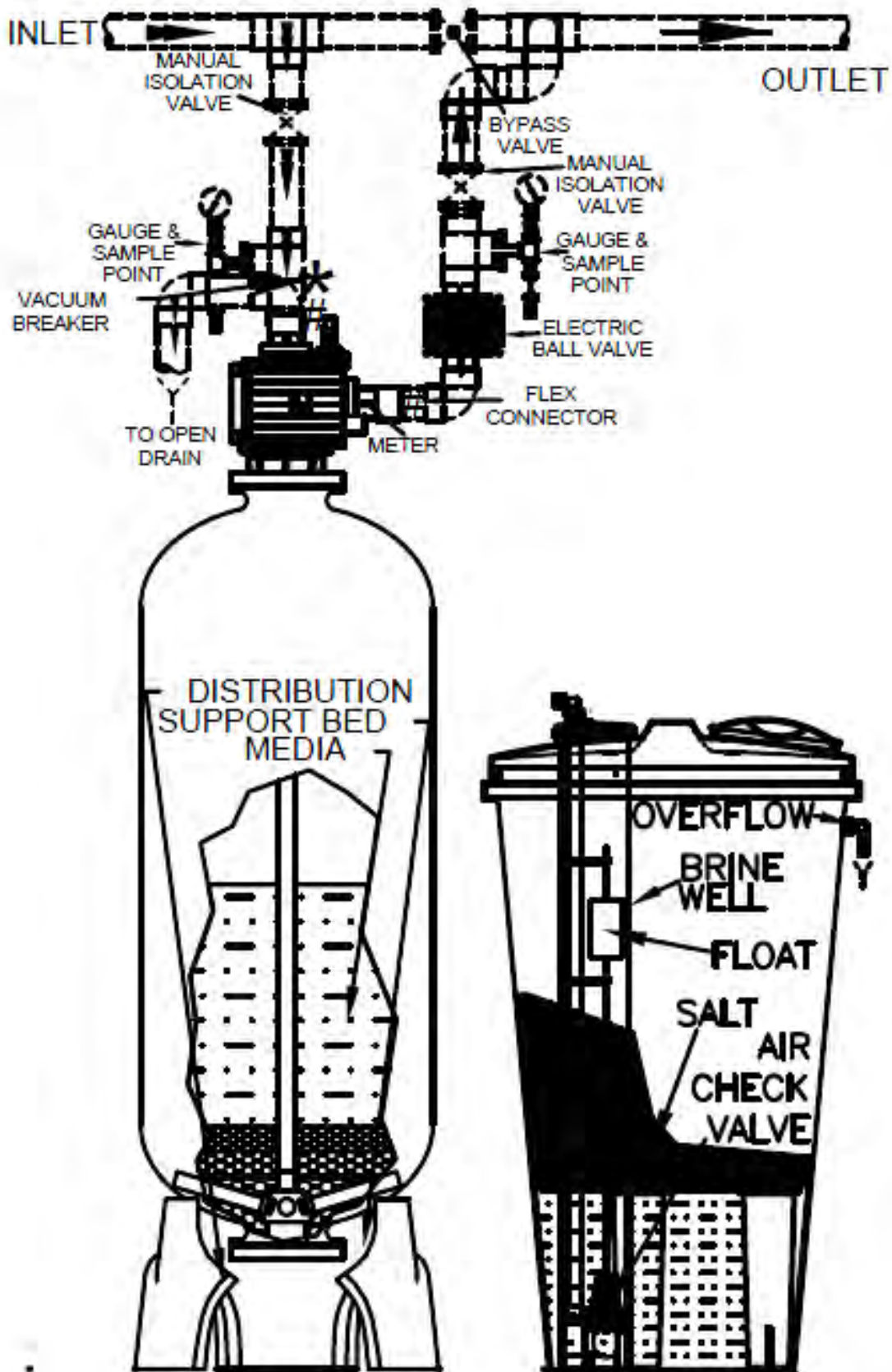

Note: Ball valve used on MTS version only. All standard softener valves use raw water for regeneration. The STS standard softener has raw water bypass during regeneration.



**Typical Piping Responsive Flow Duplex Softener System.**

**Section 3.3**

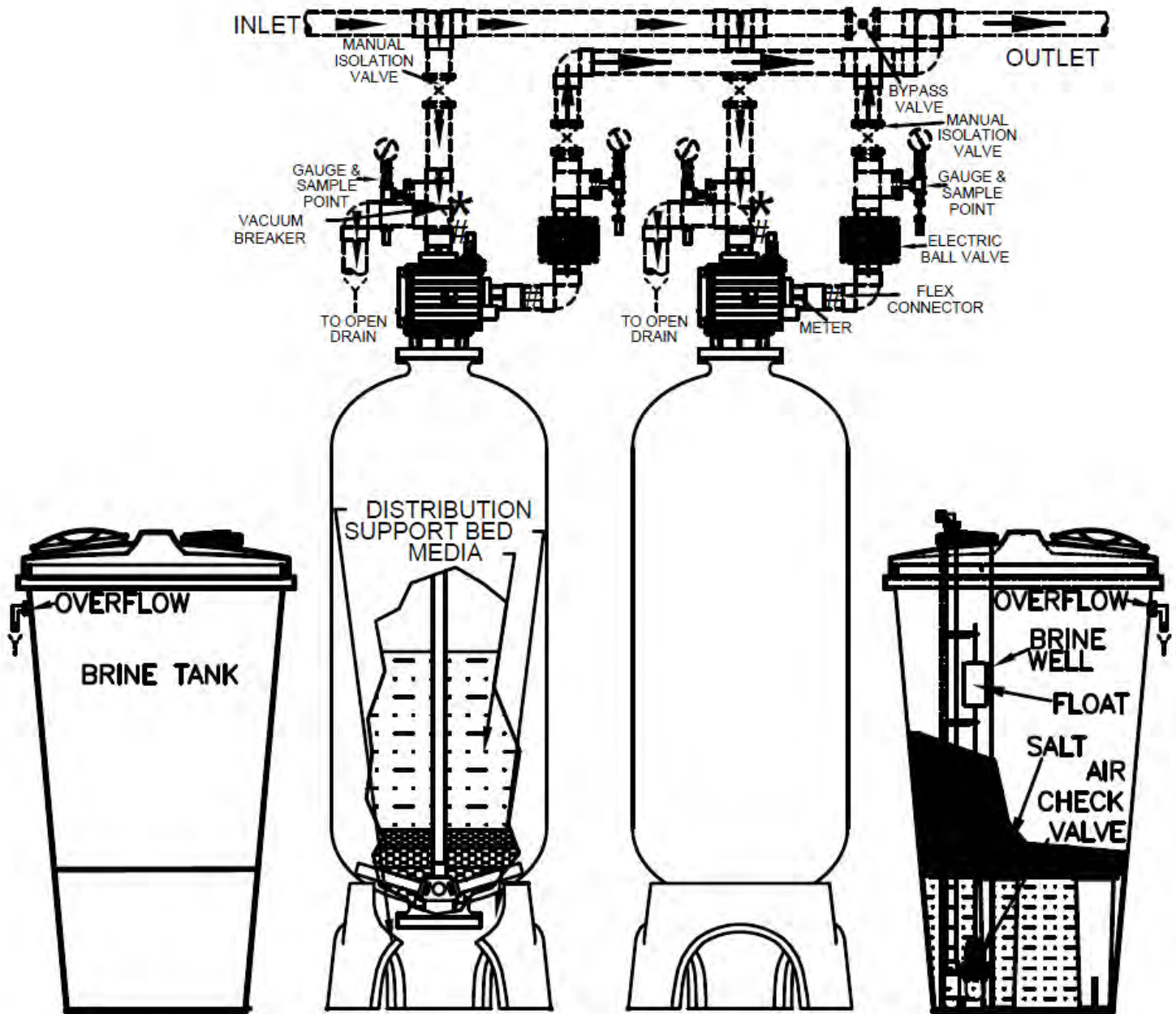

Note: Brine tanks can also be located in front of or behind media if required. Brine tank must still be within approximately 5 feet (1.5 m) of the softener. Ball valve is closed during regeneration and when unit is in standby.

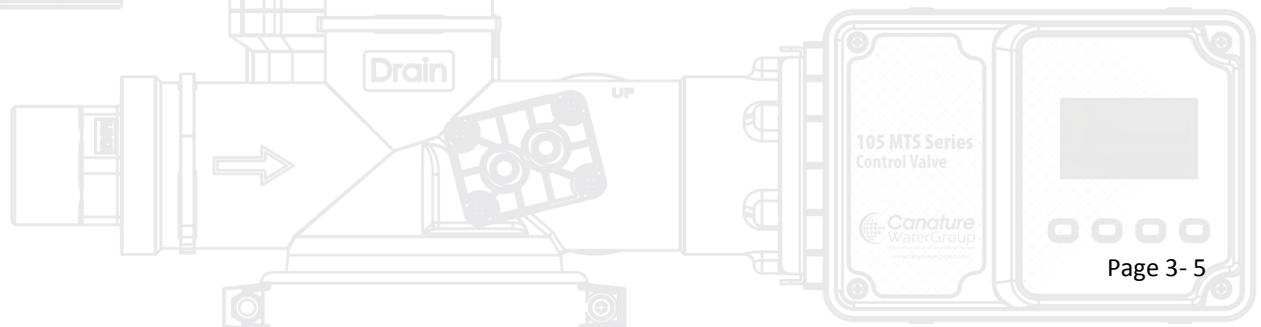

**Typical Piping Triplex Responsive Flow Softener Unit.**

**Section 3.3**

Note: Brine tanks can also be located in front of or behind media if required. Brine tank must still be within approximately 5 feet (1.5 m) of the softener. Ball valve is closed during regeneration and when unit is in standby. Softeners use raw water for regeneration.

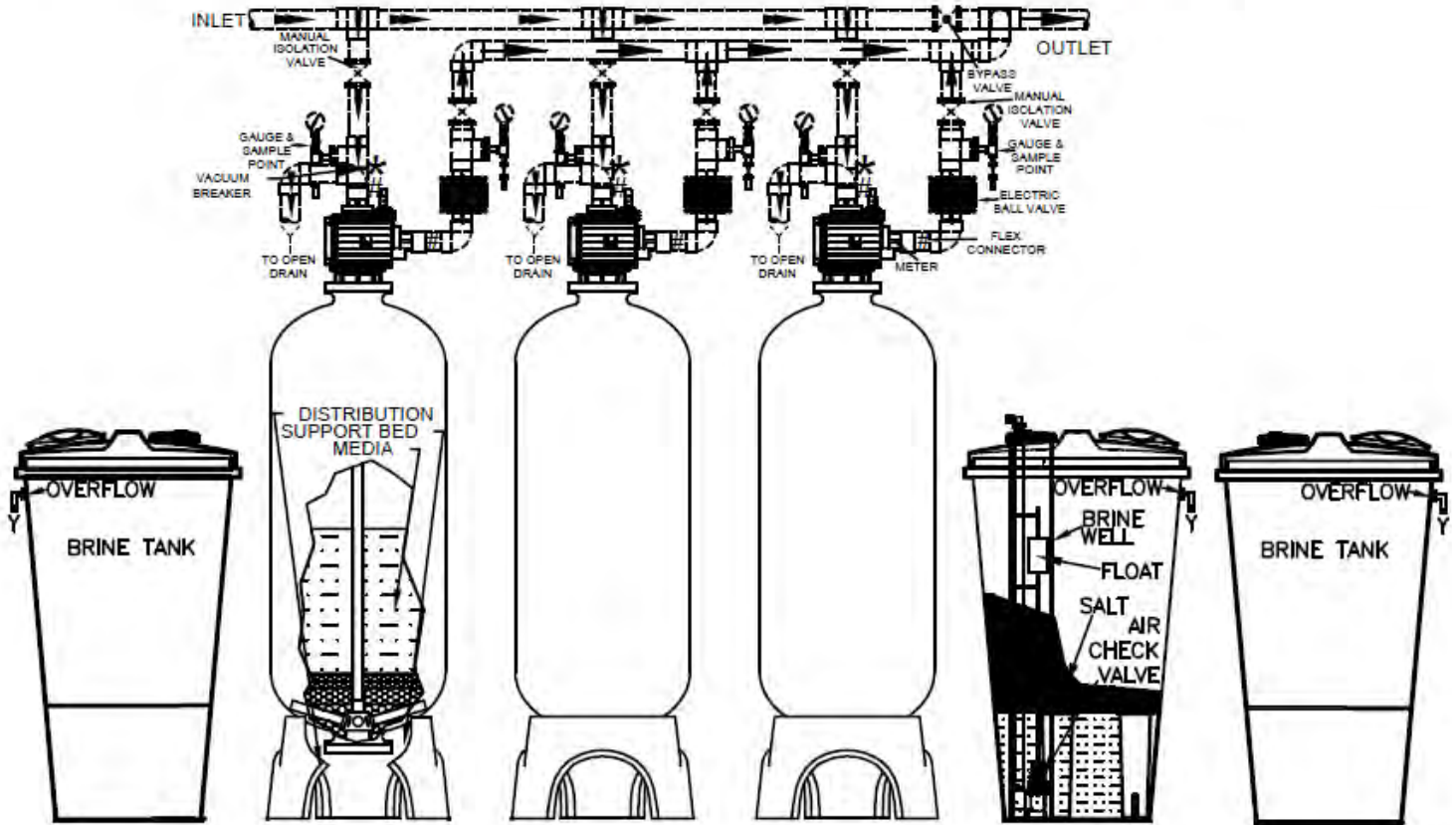

105 MTS Series  
Control Valve

Canature  
WaterGroup

### Typical Piping Quadplex Responsive Flow Softener Unit.

### Section 3.3

Note: Brine tanks can also be located in front of or behind media if required. Brine tank must still be within approximately 5 feet (1.5 m) of the softener. Ball valve is closed during regeneration and when unit is in standby. Softeners use raw water for regeneration.

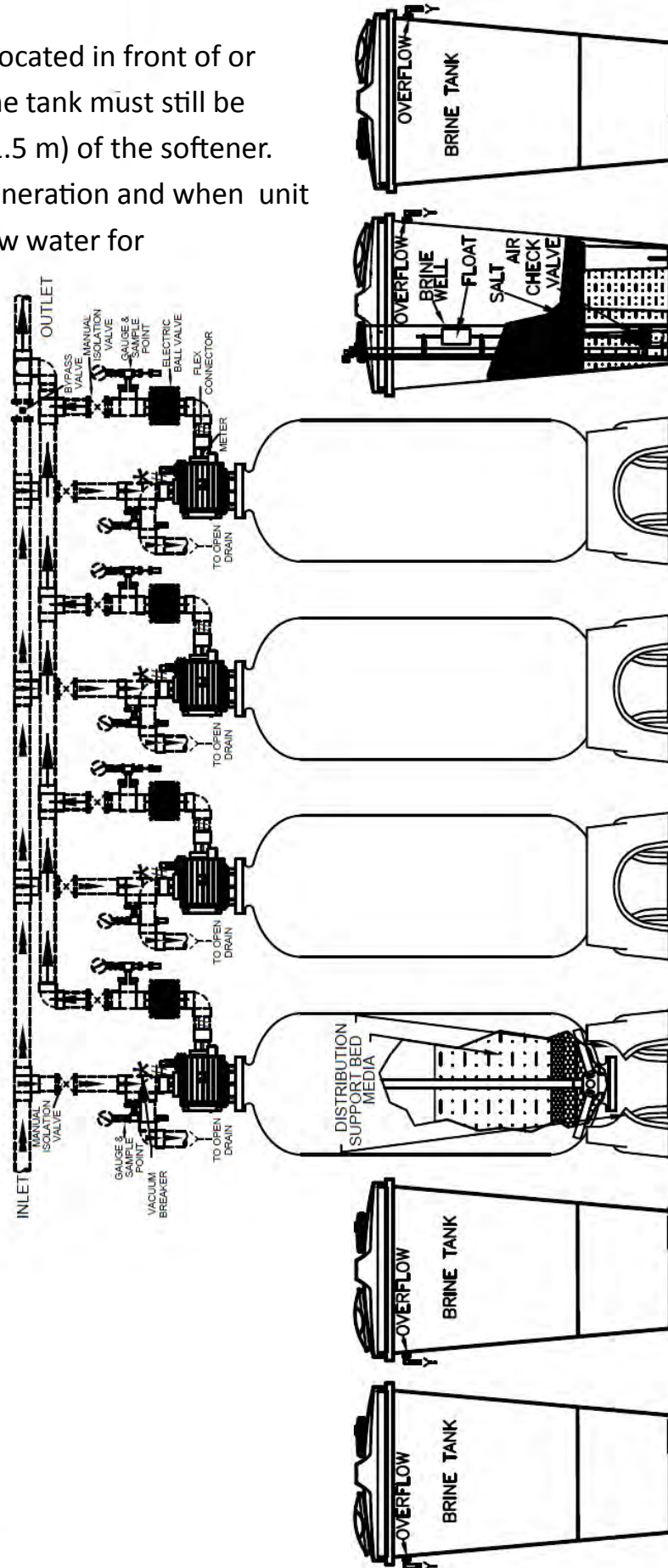



### Typical Softener Piping . Optional Separate Source Treated Water Regeneration Section 3.4

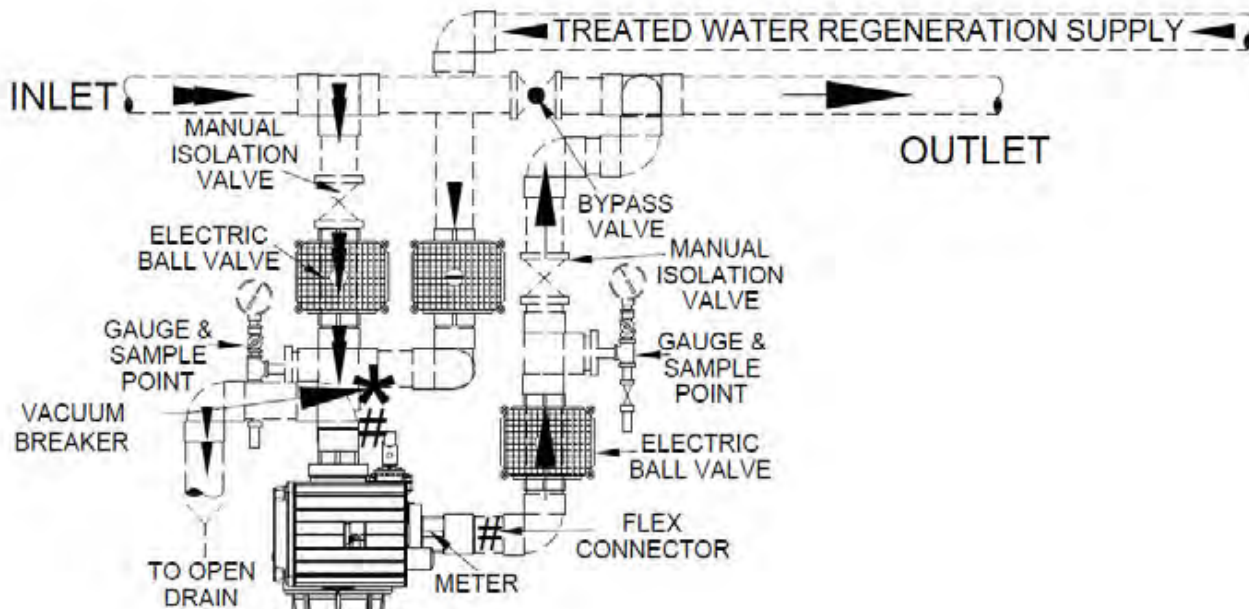

**Single tank system.**

**Note: Outlet ball may not be required for some systems.**

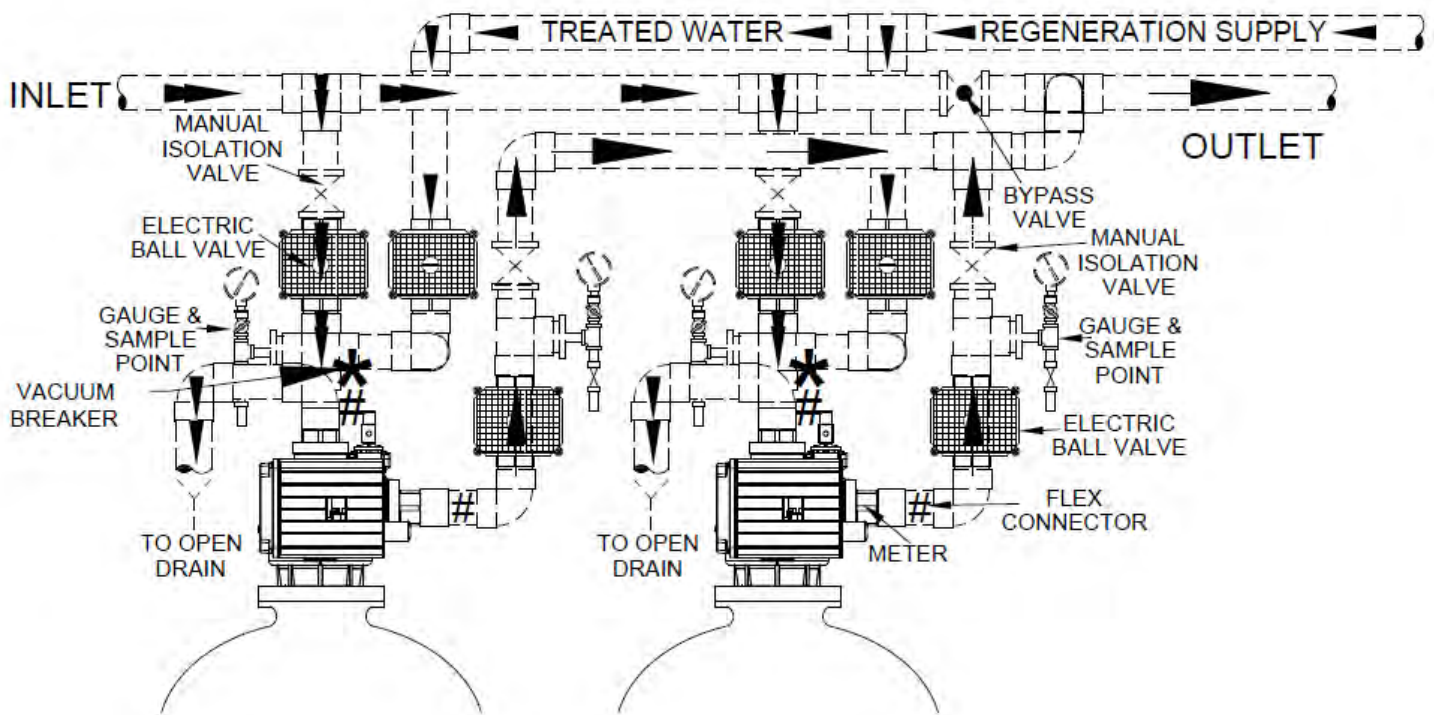

**Multi Tank System.**

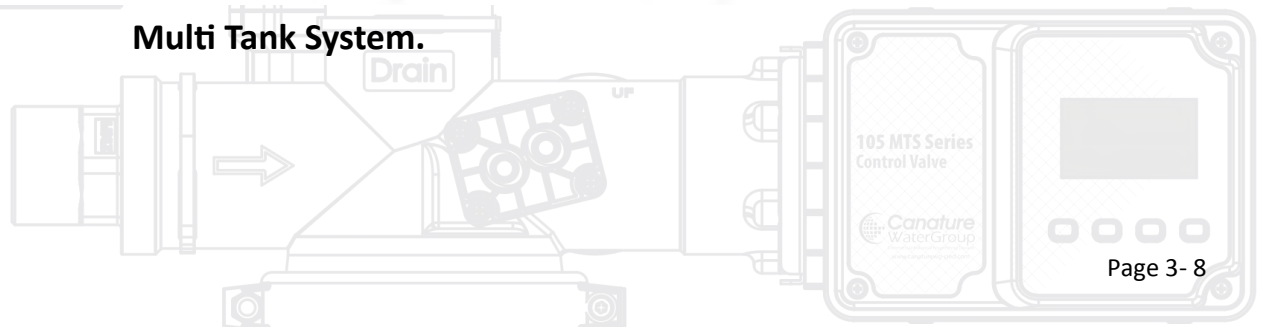

## General installation Guide

## Section 4.0

- Section 2 outlines the space required. Section 3.1 outlines the location parameters that must be considered before starting the installation. General installation diagrams are also located in section 3.

## Tank Positioning

## Section 4.1

- Select the site for the installation (See section 3). The tanks should be located on a level support pad with adequate space on all sides. The system must be close to a drain that is capable of handling the maximum regeneration flow rate. Units should be within 3 feet of one another for the communication cables.
- Position the tanks as shown on the system drawings (see section 3). Check the tank orientation to ensure the piping will properly line up. If the tanks have tripod bases or separate legs, they must be securely fastened to the floor when tank locations have been finalized. Six 3/8" lag bolts with washers (2 per leg) are recommended.
- Check the internal hub and laterals distribution system for any damage that may have occurred in shipping. This inspection is critical because if the distribution is broken, the media will be flushed into the service lines. Also note that the riser tube on the 105 valve is cut 1/2" below the top of the tank (see section 5).
- Load the media into the tanks. **See section 5** for the media loading procedure.

## Piping

## Section 4.2

- Due to slight expansion and contraction of the tank, piping must allow some movement. **If rigid piping is used, flex connectors must be used between the hard piping and to unit connections as well as any other connections to the tank. An adequate vacuum breaker must also be used to protect the tank any vacuum condition that could occur. Failure to install or improperly install flex connectors and vacuum breakers where required may void the warranty.**
- Install the piping conforming to state, federal, provincial and local codes. All government codes and regulations governing the installation of these devices must be observed.
- Flanges or unions must be installed close to the control valves. This will allow piping to be removed for any servicing of any of the system components. Each unit requires an inlet and outlet isolation valves are required as well as a full system bypass valve.
- Sample points and pressure gauges are required on the inlet & outlet of each unit. An air release (if required) should be installed at the highest point on each unit (by others).



- All piping must be properly supported and braced to keep the weight off of the valve.
- On multiple tank systems, to promote equal water flow through each unit, the overall pipe length to each unit should be as identical as possible. Use the same pipe lengths and fittings on connections to each unit. See below. All installation diagrams for single, duplex, etc. are in section 3.

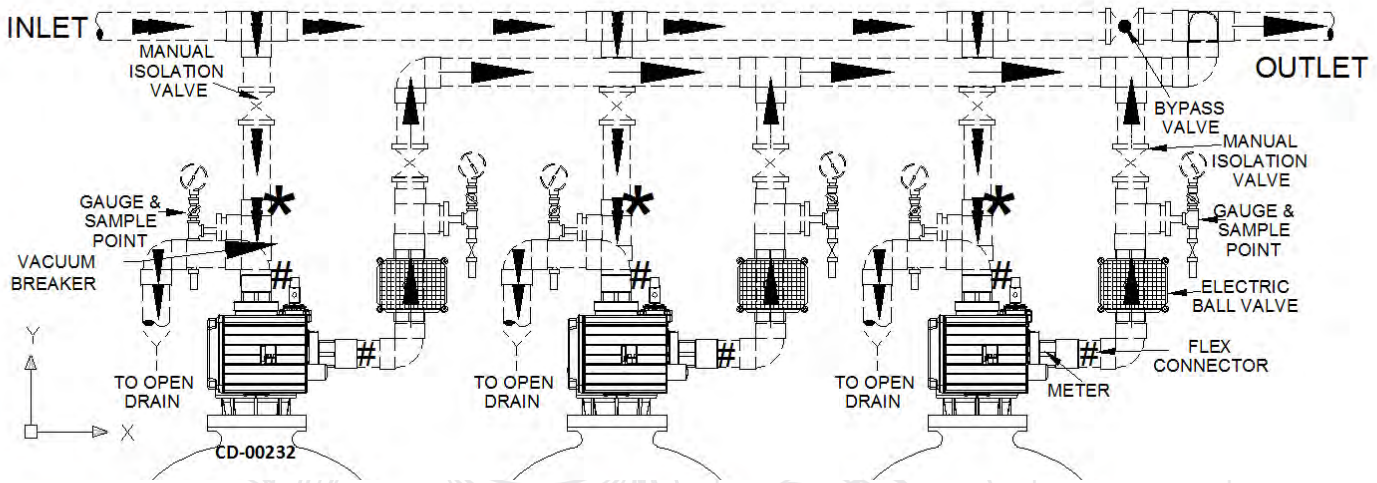

- The drain lines should be as short as possible and must piped to an open drain. Access to the drain and air gap are necessary for visual inspection and testing of the drain water. The air gap also prevents sewage backing up into the unit.
- If the drain travels a long distance or through a substantial elevation change down, an additional vacuum breaker is required on the drain line to prevent a vacuum on the mineral tank.
- The drain line size must be sized to easily handle the maximum regeneration flow rate with minimal pressure drop (2-4 psi). The floor drain must also be sized to handle the maximum regeneration flowrate. The 105 valve has a 1.5" or 2" MNPT connection. See section 2 for specifications.

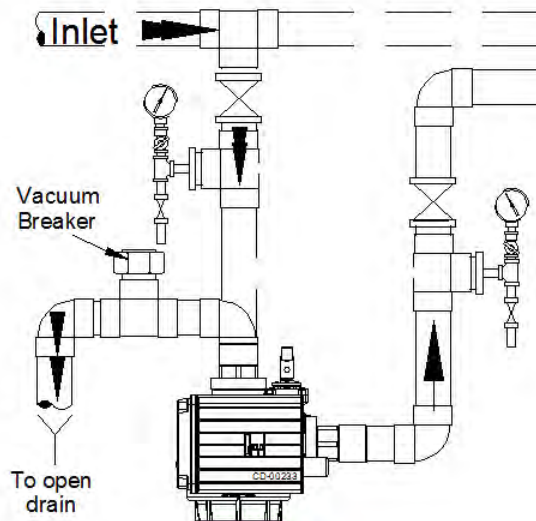



Special Piping Applications

Section 4.3

- If the treated water is flowing into an open reservoir then it is recommended that a loop with a vacuum breaker to be installed on the outlet line. This would eliminate the chance of causing a vacuum condition on the tanks when water is flowing into the reservoir as well as preventing the water in the units from siphoning down when not in operation. If the units did drain down, it could lead to operational issues for the system.

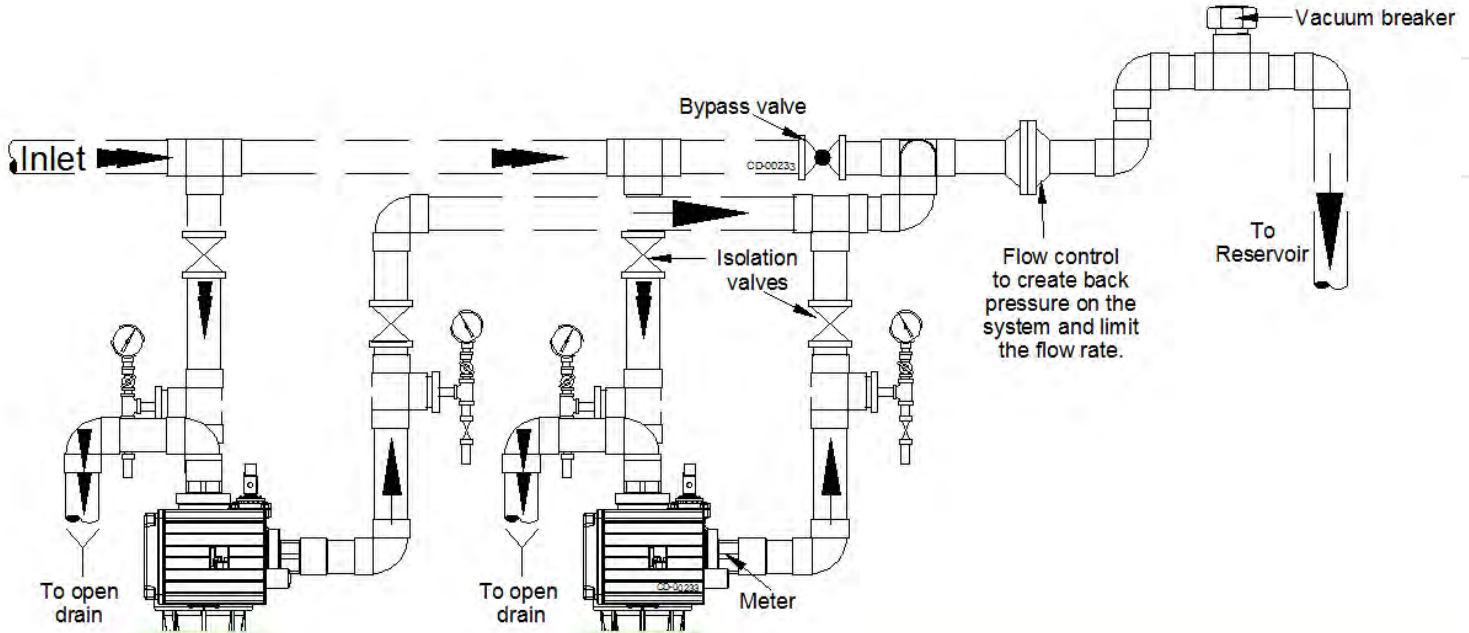

- If the system requires treated water regeneration, additional room will have to be left open for additional valves. Usually if it is a softener system, a three ball electric ball valves are required. If it is a filter system, normally only two electric ball valves are required.

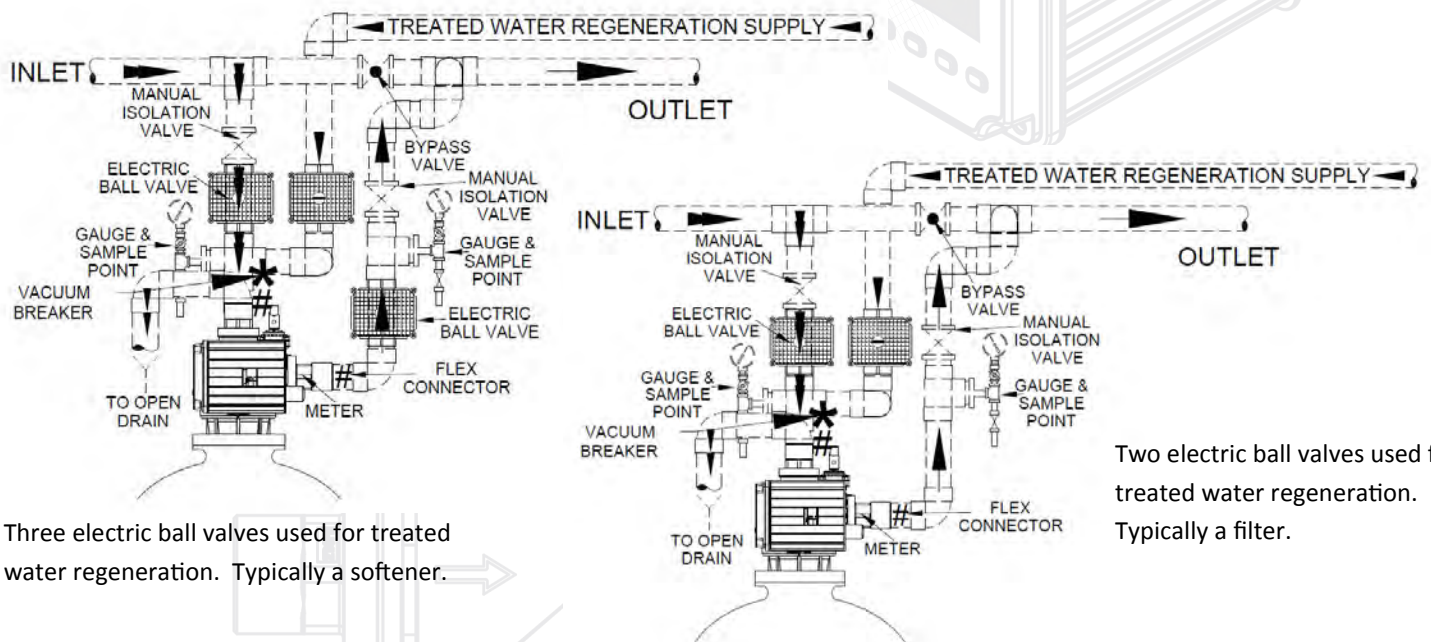

Three electric ball valves used for treated water regeneration. Typically a softener.

Two electric ball valves used for treated water regeneration. Typically a filter.

**105 Control Valve**

**Section 4.4**

- When ordered as a system, the control valve is already set up for the system with the proper backwash flow controls, etc.
- The valve piping connections are shown below. See section 2 for standard connection sizes for individual units.

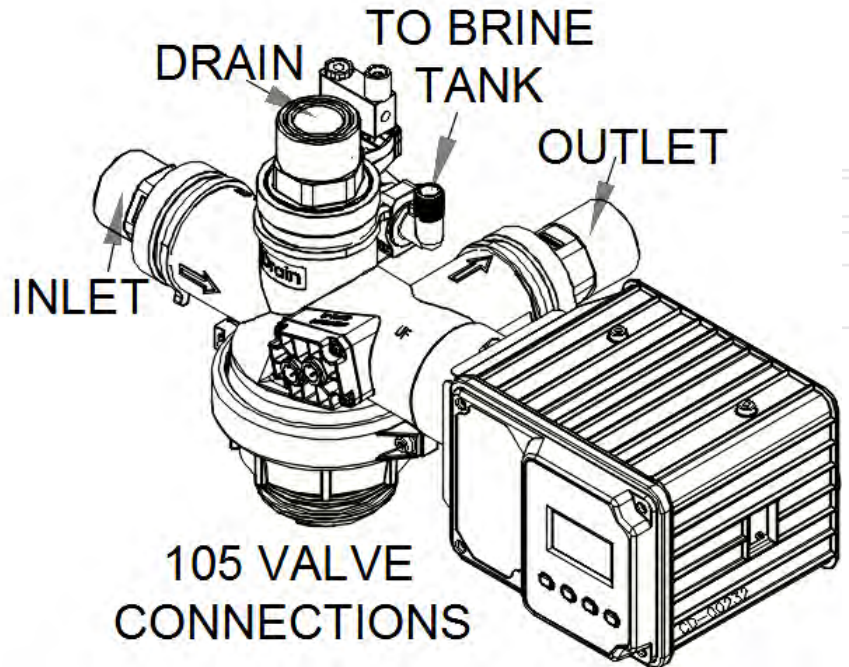

- Inlet connection 1.5" or 2" MNPT
- Outlet connection is 1.5" or 2" MNPT and has the meter mounted internally. For more information see section 10. **Confirm meter cable is properly inserted into the meter pipe adapter.**
- Drain connection is 1.5" or 2" MNPT and for most units, has the backwash flow controller mounted internally.

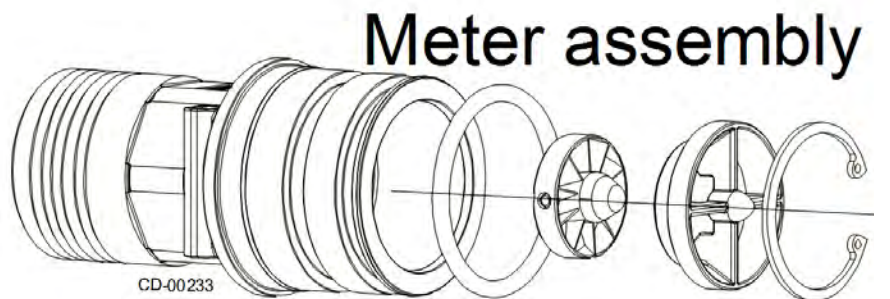

**DLFC flow control assembly**

- Brine line connection (also used on a few specialized filters) is 3/4" thread. When required, the valve is supplied with an adapter to connect to 3/8" or 1/2" tubing. NOTE: for units larger than 450,000 grains, the brine line piping is 3/4" or 1" pvc and is not supplied.

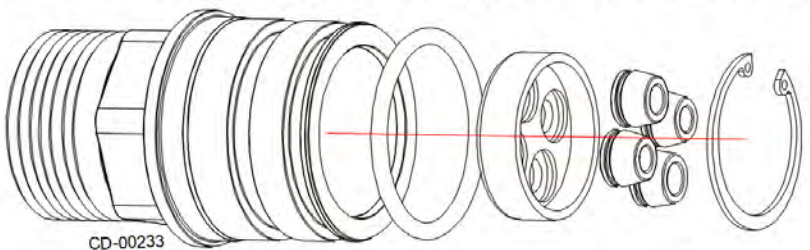



Installing The Control Valve

Section 4.4

- Before mounting the control valve on top of the tank, it is recommended to fill the tanks with water. This will give the media time to soak .
- Ensure the riser tube is 1/2" below the top of the tank.

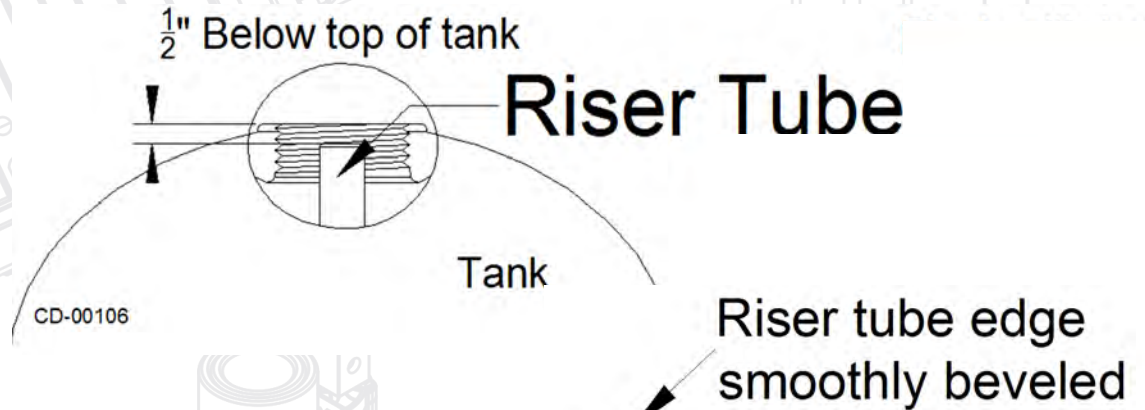

-The riser tube top end must also be properly chamfered to prevent damage to the riser tube o-ring while sliding the control valve on.

- Confirm both the riser tube o-ring and tank to valve o-ring are in place and well lubricated using silicone grease.

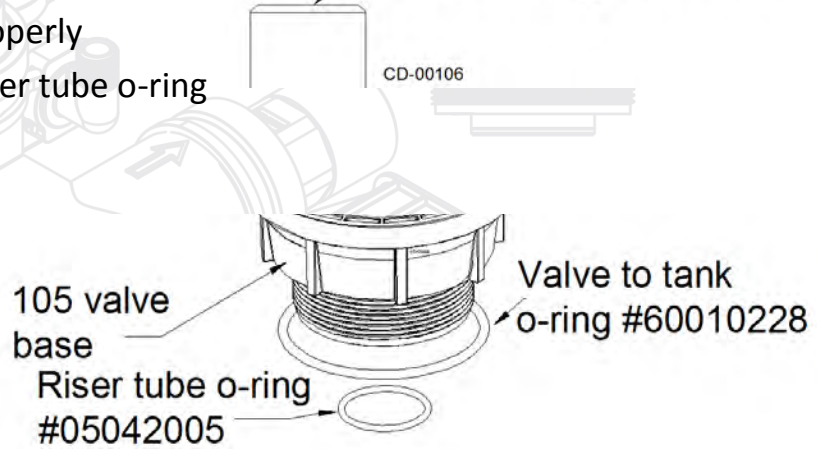

-The top portion of the 105 valve swivels on the bottom tank adapter base. Use a strap or chain wrench on the bottom tank base only when tightening the valve on to the tank.

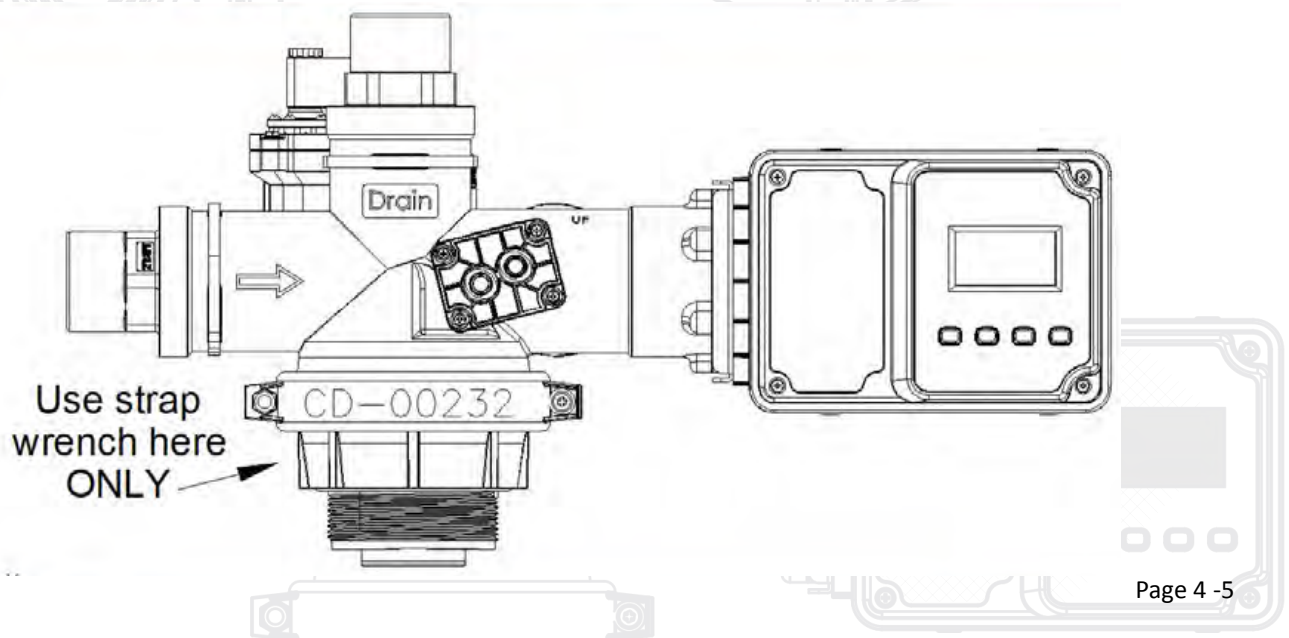



**Installing The Control Valve**

**Section 4.4**

- Confirm both the riser tube o-ring and tank to valve o-ring are in place and well lubricated using silicone grease. Ensure the riser tube is 1/2" below the top of the tank. The riser tube top end must also be properly chamfered to prevent damage to the riser tube o-ring while sliding the control valve on.

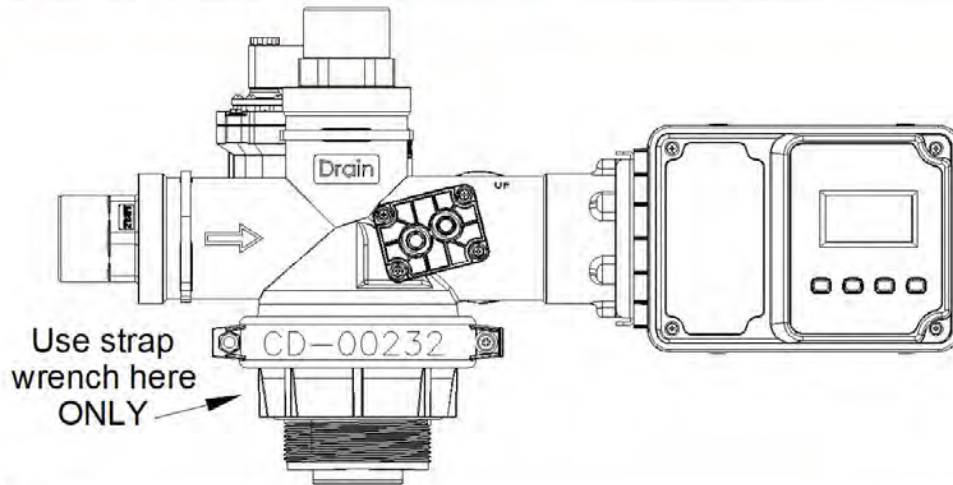

**-Note: Due to slight expansion and contraction of the media tanks, the piping must be designed to allow some movement as well as protection from vacuum, flex connectors and a vacuum breakers may be required. Failure to install or improperly install them will void the warranty. See drawing.**

- If the interconnecting piping is rigid, such as when the piping is in copper, flex connectors must be installed on all connections to control valve. A flex connection may also be required on the drain line as well if the piping is rigid. The standard systems do not include flex connectors but can be supplied as optional items with the system.

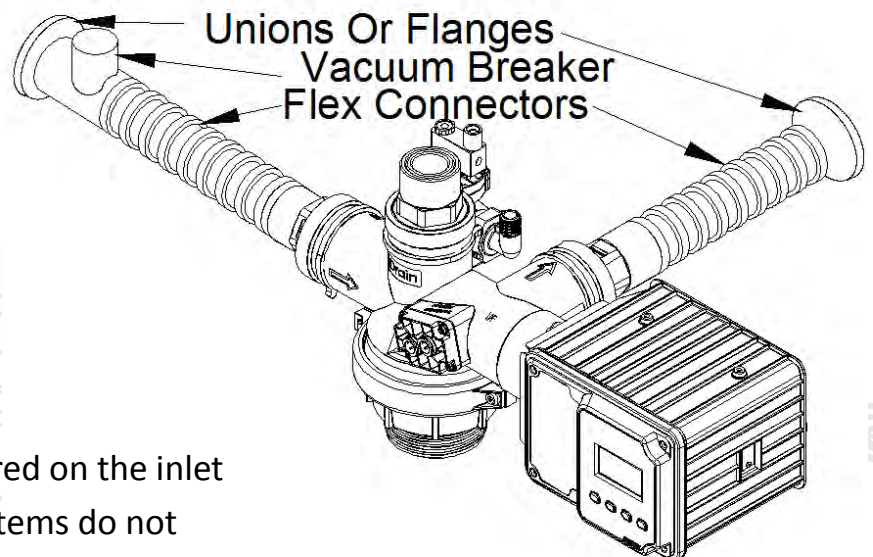

- A vacuum breaker is normally required on the inlet of each media tank. The standard systems do not include vacuum breakers but can be supplied as optional items with the system.

**Brine Tank Connections**

- Place the brine tank within five feet of the mineral tank. The brine tank must be on a smooth surface as uneven surfaces or protrusions could cause the brine tank to puncture or break. Keep the brine line to the softener as short as possible.

- Keep the brine line as short as possible. The brine line should not be more than 6 feet long.

- If multiple softeners (not normally recommended except for alternating units) are using the same brine tank, the brine line is teed off to the two different units.

- The brine tank overflow is piped to an open drain (piping by others). The overflow is gravity feed so the overflow hose must not rise above the height of the overflow fitting.

Brine Line Connection Size		
Up to 120,000	Up to 4 ft <sup>3</sup> resin	3/8" tubing (supplied)
150,000 to 450,000	Up to 15 ft <sup>3</sup> resin	1/2" tubing (supplied)
Above 450,000	Over 15 ft <sup>3</sup> resin	Brine line to be piped in 3/4" or 1" pvc (by others)

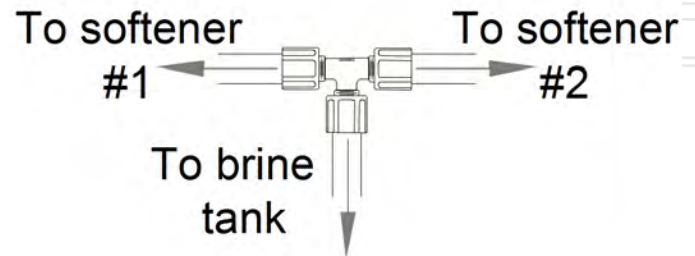

Brine line connection

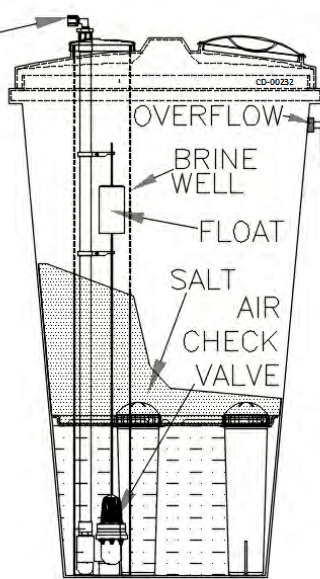

Overflow is gravity feed. Do not elevate hose above the overflow fitting.

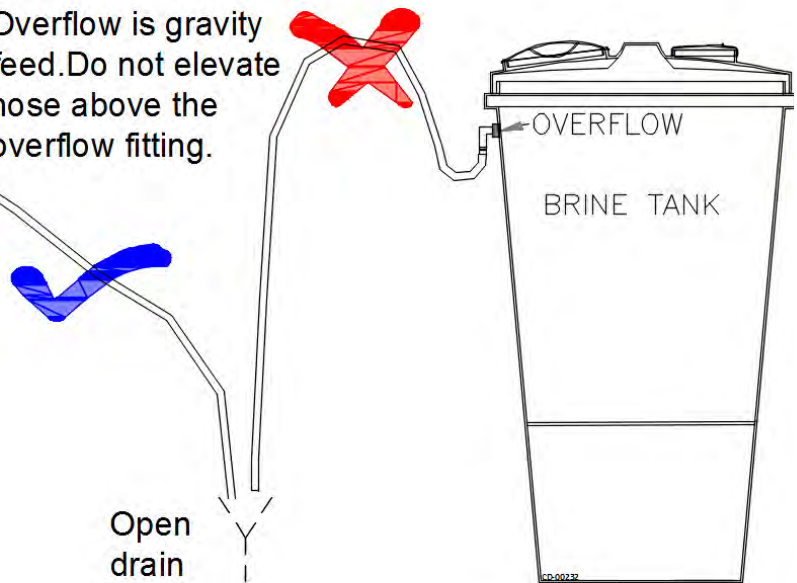

- Once the brine tank has been placed in the proper location and the brine line connected, fill the brine tank until the water level is 3 or 4 inches above the grid. A few bags of salt can now be added. In operation, to ensure the system has fully saturated brine, it is important to keep the salt above the level of the brine.



**MTS Wiring Connections**

- The wiring for the MTS system is straight forward. The system has two, three and four pin connectors.
- The two conductor jack from the transformer connects to the MTS main controller via the 2 pin connector.
- The other connection on the MTSB controller is a four pin connector. The four pin connector supplies both power and communication to all the 105 control valves.
- On each 105 control valve, it has 2 four pin connectors and a three pin connector.
- The four pin cable connector can plug into either one of the four pin connectors on the valve. The other four pin connector is used to connect to the next valve. The valves are wired in series.
- **NOTE: It is important that each valve has it's own unique number. For example the system will not operate properly if you have two valves that are #1.**
- The three pin connection is for connecting to the electric ball valve (if required).
- See section 8 for programming.

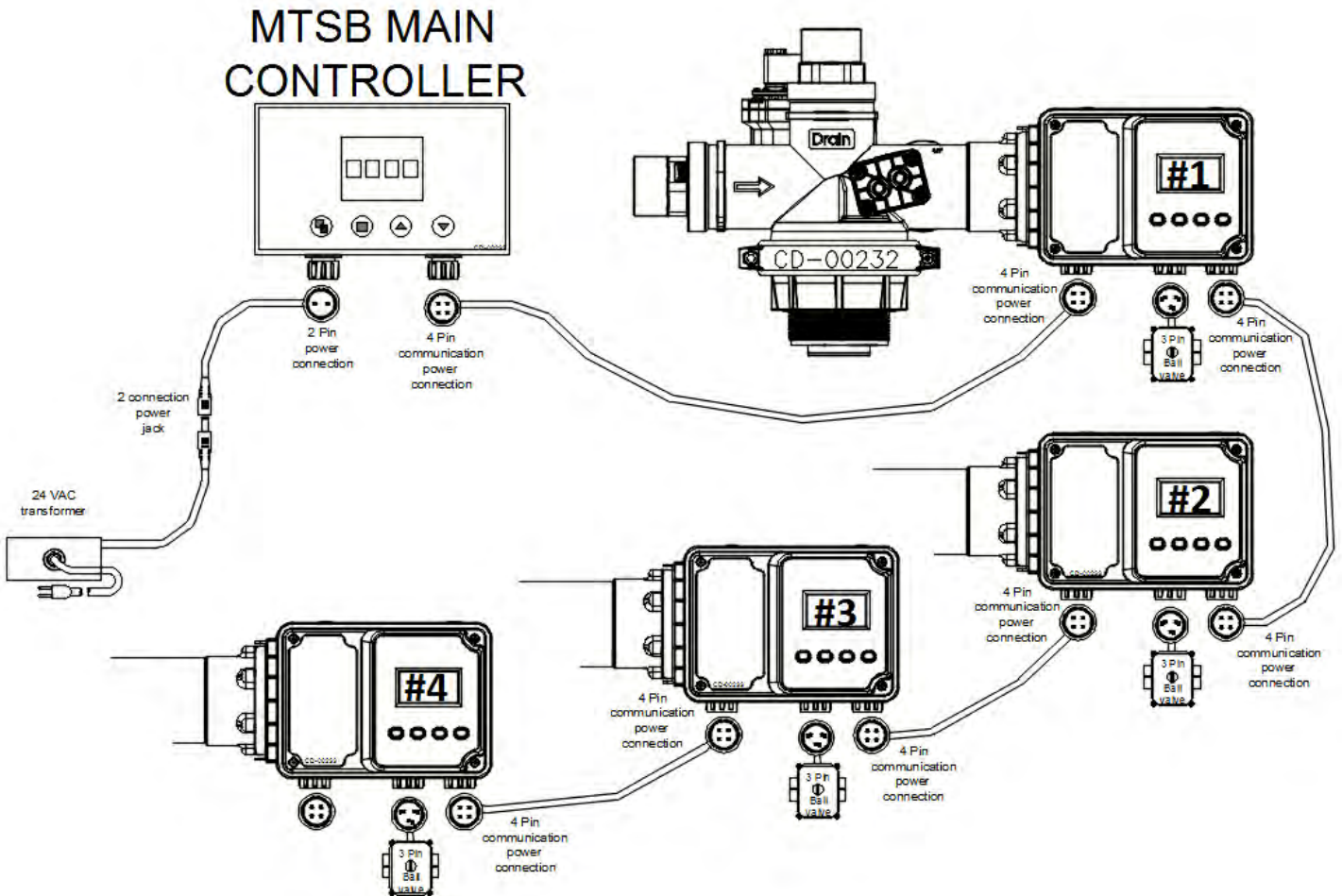



**Media Loading**

**Section 5.0**

**– Before you start to load the media, check all of the following:**

**\*\*NOTE: FOR ANY UNITS WITH TOP MOUNTED CONTROL VALVES, IT IS CRITICAL TO BE SURE THE DISTRIBUTION REMAINS CENTERED IN THE TANK AND STAYS ON THE BOTTOM OF THE TANK WHILE FILLING THE TANK WITH MEDIA. *If the distribution is not properly held down & centered, the media may have to be removed and redone.* \*\***

- Check the media list and confirm you have all the media required (see following tables). A large neck funnel will make the media loading easier. **Optional #99004**



- Before the media is loaded, the bottom distribution must be closely inspected to ensure it was not damaged in shipping. If the distribution is cracked or broken, it must be repaired before proceeding.

- If there are any riser pipes or any open distribution connections inside of the tank, ensure these connections are properly plugged so no media can enter them.

- Ensure the riser tube has been cut to the proper length and the riser end has been smoothly beveled. **NOTE: Depending upon the control valve used, the riser tube will have to be cut to different lengths.** On 95 series & 105 series control valves, the riser tube is cut 1/2" below the top of the tank. With most other control valves, the riser tube is cut flush with the top of the tank.

105 valves

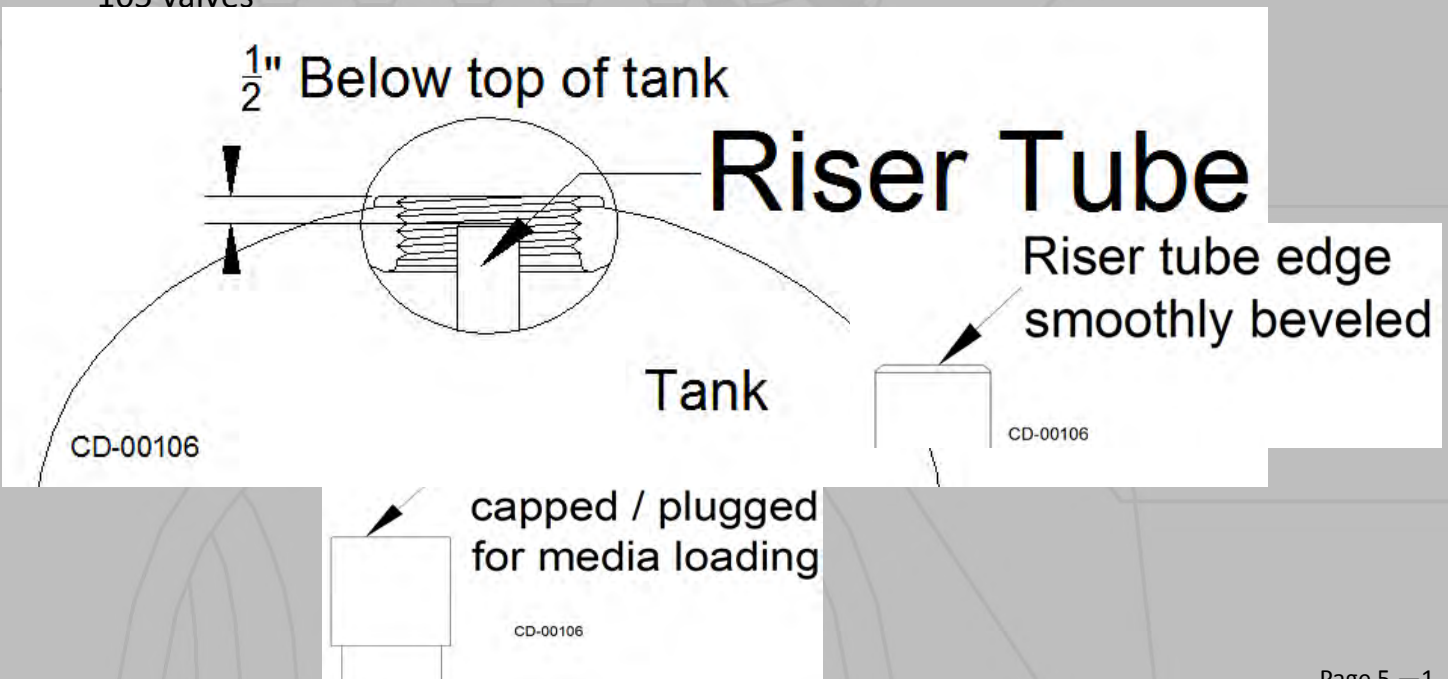

## Media Loading

### Section 5.0

- Check the location and orientation of the tank. Ensure the tank is in the proper location so the unit connections will line up correctly with the piping. If required, test fit the valves & manifolds to be sure. If the unit has a side mounted manifold, occasionally tank shims are required between the tank and the floor to ensure piping / manifold will have a minimum of 1/2" clearance. If required, install shims before starting to load the tank. Make sure the tank is properly installed (tripod base tanks should be secured to the floor). It is very difficult to move a tank once the media has been loaded and may damage the tank.
- Fill the tank approximately 1/3 full of water. This will help protect the laterals from the media being poured in. Distributions tend to float up once water has been put into the tank so confirm that the distribution is being held on the bottom of the tank and is centered. Confirm the riser tube is plugged so no media will enter the distribution.
- Check the media list and start from the bottom up. Ensure the proper amount of each type of media before moving on to the next media. It is common to have additional partial bags to add up to the required quantity of each media.
- The support bed media is first (coarse gravel first, then medium gravel followed by fine gravel etc.). Pour the gravel so it is evenly spread out in the tank (use a circular pouring pattern). Note that the gravel will not level out on its own when backwashed. It must be manually levelled. To check the level, the water can be drained down until the media just starts to poke through the water surface. This will help determine if the media is level. The most important layer to get as level as possible is the top of the support bed, the fine gravel. The gravel will not move during backwash. If, for example, all the gravel has been poured to one side, the unit will not have even flow distribution and the unit will not perform as intended.
- Once all the media has been loaded, unless there are special instructions not to, the media tanks should be filled with water to allow the media time to soak. If possible allow the media to soak for several hours, preferably over night.

**Media Description**

**Section 5.1**

Aquafine AQ100-Na Cation Resin.



This product has been tested and certified to meet the material requirements of NSF/ANSI Standard 44.

C USA

**Physical & Chemical Characteristics**

Polymer Matrix Structure	Polystyrene 8% cross-linked with Divinylbenzene
Physical Appearance	Amber spherical beads
Whole Bead Count	90% minimum
US Standard Mesh Size	16 - 50
Ionic Form as shipped	Sodium (Na+)
Approximate Shipping Weight	53 lb / cubic foot (850 grams / litre)
Total Capacity in the Sodium Form	1.9 meq / ml
pH Range, Stability in the Sodium Form	0 - 14

Media	Description	Density (lb/ft <sup>3</sup> )
Cation Resin	AQUAFINE AQ100-Na is a premium high capacity gel polystyrene strong acid cation exchange resin supplied regenerated in the sodium form. This resin has been certified to meet the requirements of NSF/ANSI Standard 44.	53
Fine Gravel	1/8" x 1/16" graded and washed quartz (50 lb bags)	100
Medium Gravel	1/4" x 1/8" graded and washed quartz (50 lb bags)	100
Coarse Gravel	1/2" x 1/4" graded and washed quartz (50 lb bags)	100

**Media Beds Quantities**

**Section 5.2**

**Special Media Loading, (Optional)**

**Section 5.2.1**

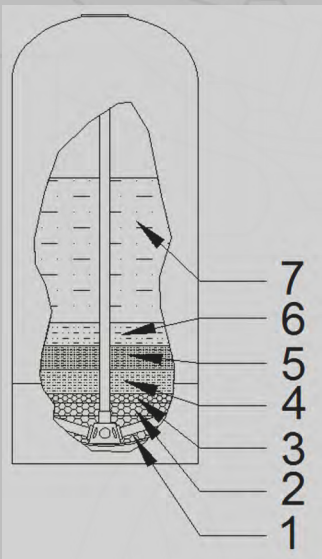

Layer	Media	Quantity
1 Bottom Layer		
2		
3		
4		
5		
6		
7		
Top Layer		



**Media Beds**

**Section 5.2**

Softener (FT <sup>3</sup> )							
Softener Size	Part #	Coarse Gravel	Medium Gravel	Fine Gravel	Resin	Weight	
		#1	#2	#3	#4	LBS	KG
90	410003	0.15	0	0.15	3	226	103
120	410004	0.2	0	0.15	4	278	126
150	410005	0.2	0.15	0.1	5	345	157
180	410006	0.2	0.15	0.15	6	402	183
210	410007	0.2	0.15	0.15	7	454	206
240	410008	0.3	0.2	0.2	8	526	239
270	410009	0.3	0.2	0.2	9	578	263
300	410010	0.3	0.2	0.2	10	630	286
360	410012	0.4	0.35	0.35	12	774	352
390	410013	0.4	0.35	0.35	13	826	375
450	410015	0.4	0.35	0.35	15	930	423

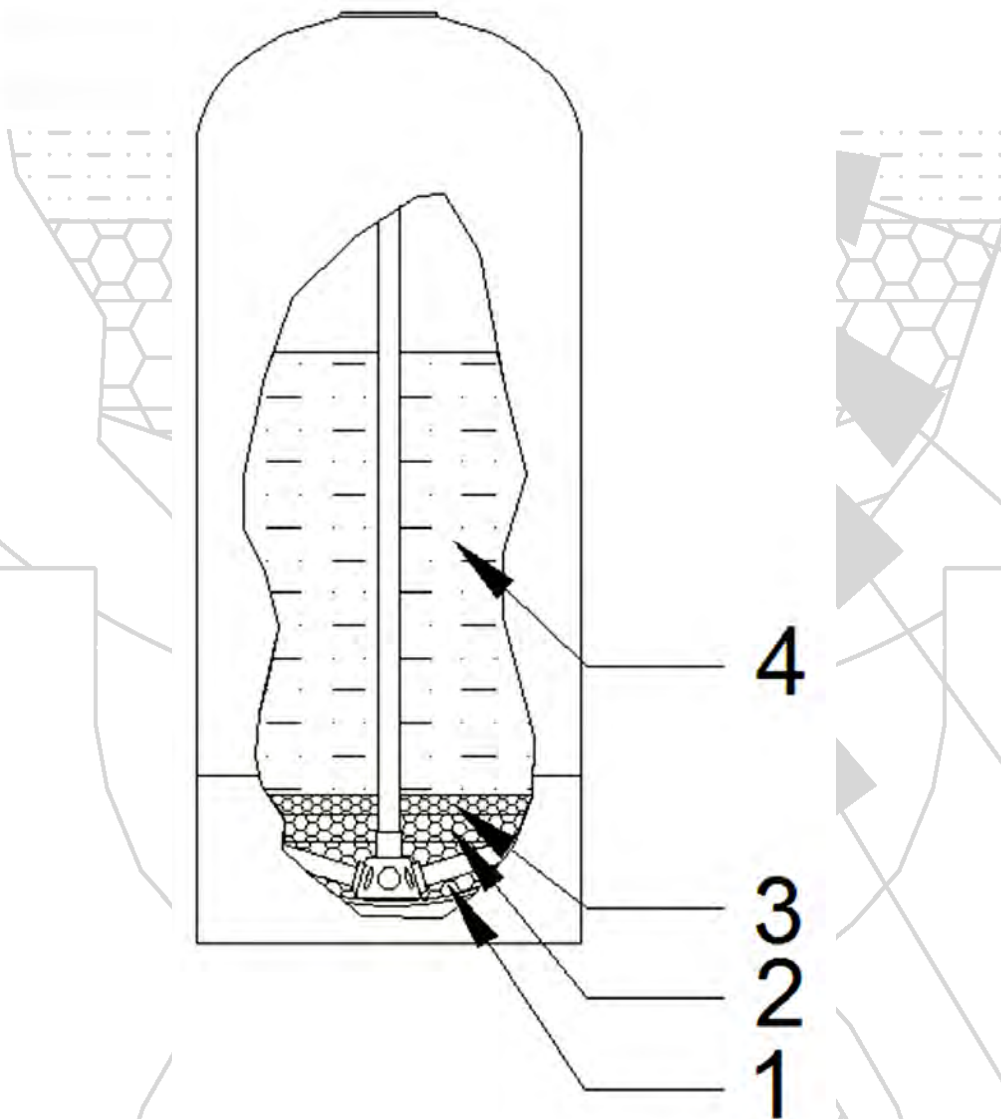

## Information Required And Overview For Start-up

## Section 6.0

NOTE: It is important to follow the startup instructions. Improper start up may result in unsatisfactory softener operation or possibly damage the softener.

### Required information required to start up the softener.

- The raw water analysis is required to start up the softener. The total hardness and iron and manganese levels.
- If the softener was ordered as a complete system, the control valves and MTS controller are already programmed with a couple of exceptions (parameters). These are shown in section 6.1.
- The rest of the parameters are pre-programmed, *but should be reviewed to confirm* they are set as intended (see section 2 for regeneration cycle times). These settings may also be modified on site if required to better suit a particular application.
- The complete programming guide is in section 8. However, for start-up in section 6.2, there is also a condensed version of the programming guide for the standard responsive flow softener system. In section 6.2 is a short start-up list that covers the programming of the exceptions that were not pre-programmed as well as most of the other settings that should be reviewed.

## Programing Parameters—Calculating Total Hardness

## Section 6.1

- The first parameter set on site is the time of day. See section 6.2 for programming.
- The second parameter is the calculation of the total individual softener **capacity in gallons**. This is site specific and totally dependent upon the raw water conditions. There are a couple of steps required to arrive at the capacity in gallons.

### —Step 1

- Calculate the total compensated water hardness. The raw water analysis is required. The values required are the **total hardness** (in grains per gallon (gpg)), **iron** (in ppm or mg/l), and **manganese** (in ppm or mg/l). With these, the total compensated hardness is calculated.
- Note: If the any of the levels fluctuate, use the highest level of each component in the calculations.

105 MTS Series  
Control Valve

Canature  
WaterGroup

## Start-up

- The total compensated hardness is calculated as follows:

**Total water hardness (gpg )**

**+ Iron (in ppm or mg/l) x 4**

**+ (Manganese (in ppm or mg/l) x 8**

**Equals the total compensated hardness (gpg)**

An example of this calculation is below: and is based on the following raw water conditions.

- Total harness—10 grains, iron—0.1 ppm, manganese—0.2 ppm.

- 10 gpg of total hardness                                10

- 0.1 ppm of iron (0.1 x 4) =                                0.4

- 0.2 ppm of manganese (0.2 x 8) =                                1.6

Equals a **total compensated hardness** of **12 gpg.**

*Note: The total water hardness may be in ppm. To convert to gpg, divide by 17.1.*

Example of this is : 171 ppm total water hardness / 17.1 = 10 grains per gallon (gpg).

- Step 2

- Determine the individual softener **capacity in gallons**. This value is calculated by dividing the individual softener **grain capacity** by the **total compensated hardness**.

- The individual softener grain capacities for each size of softener are listed in the next table. There are three different grain capacities shown for each softener size. Grain capacity of the resin changes depending upon the quantity of salt used per cubic foot of resin when regenerating. Salting capacities listed are at 6 lbs/ft<sup>3</sup>, 10 lbs/ft<sup>3</sup>, and 15 lbs/ft<sup>3</sup>. Each of the three salting levels shown have their own advantages.

- Salting at the lower level (6 lbs) provides greatest salt usage efficiency. At this level the capacity is lower and will require more frequent regeneration resulting in somewhat less efficient water usage. The hardness leakage in service is also higher than at the higher salting levels.

- Salting at the middle level (10 lbs) is less efficient in salt usage than the 6 lbs setting. However with a higher capacity, the water usage will be a little better than at the 6 lb setting as the unit is regenerating less frequently.

- Salting at the highest level (15 lbs) is the least efficient in salt usage. At this setting the unit will use more than double the salt compared to the 6lbs setting. However the hardness leakage in service is the lowest, and is most efficient with water.



Softener Model	Capacity	Resin	Softener Model	Capacity	Resin	Softener Model	Capacity	Resin
	@6 lbs/ft <sup>3</sup>	Volume		@6 lbs/ft <sup>3</sup>	Volume		@6 lbs/ft <sup>3</sup>	Volume
	@10 lbs/ft <sup>3</sup>	ft <sup>3</sup>		@10 lbs/ft <sup>3</sup>	ft <sup>3</sup>		@10 lbs/ft <sup>3</sup>	ft <sup>3</sup>
	@15 lbs/ft <sup>3</sup>	m <sup>3</sup>		@15 lbs/ft <sup>3</sup>	m <sup>3</sup>		@15 lbs/ft <sup>3</sup>	m <sup>3</sup>
90	60,000	3	240	160,000	8	450	300,000	15
	81,000			216,000			405,000	
	90000	0.08		240000	0.23		450000	0.42
120	80,000	4	270	180,000	9	570	380,000	19
	108,000			243,000			513,000	
	120000	0.11		270000	0.25		570000	0.54
150	100,000	5	300	200,000	10	600	400,000	20
	135,000			270,000			540,000	
	150000	0.14		300000	0.28		600000	0.57
180	120,000	6	360	240,000	12	All capacities shown are in grains		
	162,000			324,000				
	180000	0.17		360000	0.34			
210	140,000	7	390	260,000	13			
	189,000			351,000				
	210000	0.2		390000	0.37			

105 modified-capacity table .xlsx

- The model number of the system will indicate the size of unit. The model legend is in section 2.1. Once the softener size is determined in the above table, check the programming sheet to determine what salting level the unit was factory programmed for.

-With the softener unit size and the salting level, the softener individual capacity can be found in the table above.

- To calculate the softener capacity in gallons, divide the softener capacity in grains by the total compensated hardness calculated in section 6.1

- A small buffer of 5 % will help compensate for any slight changes in the feed water .

For example, if the softener is a model MTS 300,000 and is salted at a 10 lb/ft3 level, the capacity to use is 270,000. If the compensated hardness is 12 grains, the calculation is

$$270,000 \text{ divided by } 12 \text{ grains equals } 22,500 \text{ gallons.}$$

To leave a small buffer to compensate for any variations, multiply by 0.95

$$22,500 \times 0.95 = 21,375 \text{ gallons.}$$

The **21,375** has to be programmed into the system capacity screen in the programming pages ahead.

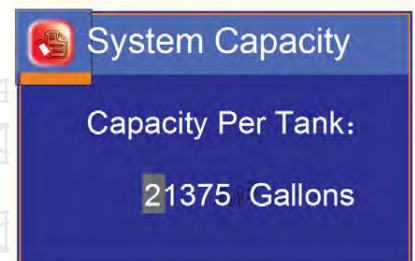

**Controller Programming Required For Start-up****Section 6.2**

- The following is a quick guide to adjust the programming with information that is site specific and must be entered. These programming changes should be updated on the system programming sheet.



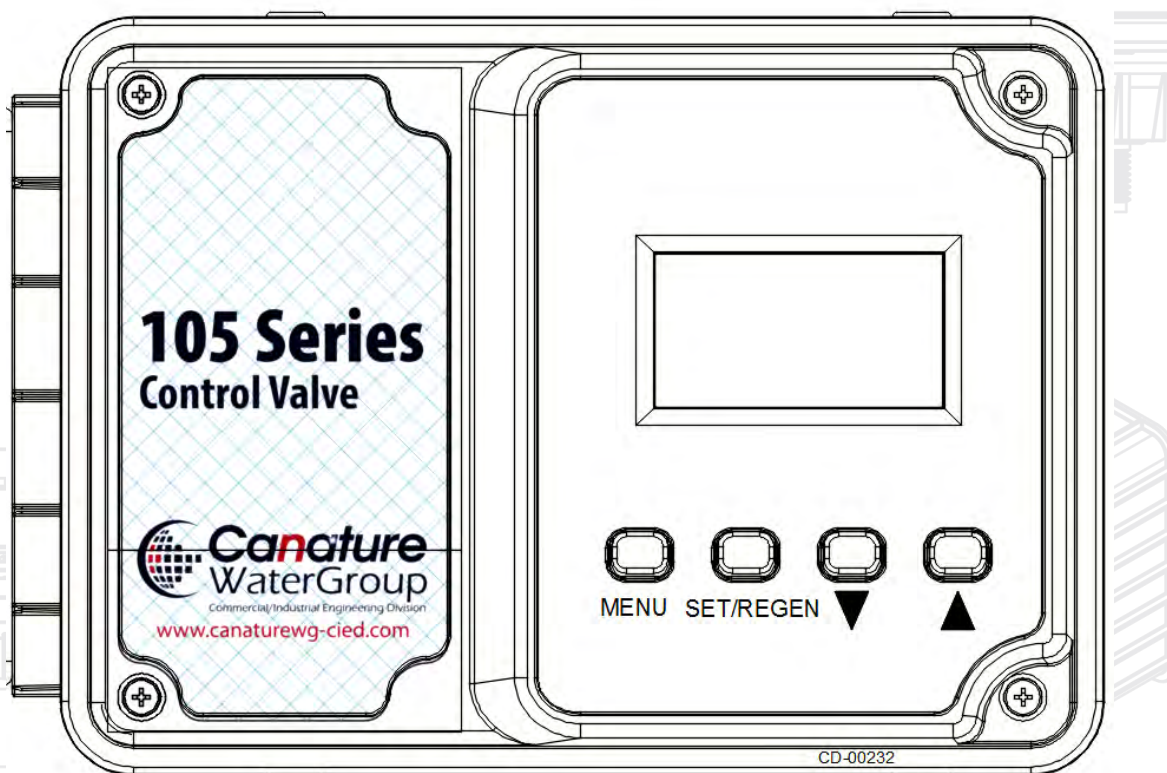

- It is recommended that the complete programming is later checked to confirm the programming is as shown on the programming sheet, updated with the site specific data. The complete programming guide is in section 8.

**Key Pad Overview**

There are four push buttons on the keypad on the 105 control valve.



**Note: MENU, SET and ARROWS will be referred to indicate which button is required to be**

- MENU "  ": This function is to enter the basic setup information required at the time of installation, or back to previous page.
- SET "  ": this function is to accept the values if changed and advance the next item in the menu.
- +/- "   ": These buttons are used to scroll the icon bar in the menu, and increase or decrease the value of the settings while in the programming mode.



MTS Controller Programming Quick Guide

Section 6.2

- The complete softener system is controlled by one central “MTS” controller.



- The MTS central controller main screen display shows the general status of the system.

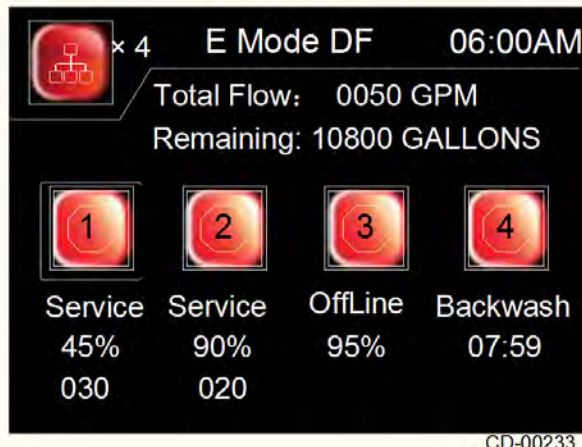

“Main” screen” display

-This screen shows the number of media tanks and each unit’s current status. This will be referred to as the “**main display**”. The status of each unit is displayed including service, offline, in regeneration or dropped (if there is a communication issue). If the unit is in regeneration, the display will show the cycle the unit is in and the time remaining. Other information displayed includes system flowrate, remaining capacity and time of day. For more information, see section 8. Please confirm the flowrate is in “GPM” and remaining volume is in “GALLON”. If not, go to section 8 and go through the “Region Language” programming. Also confirm that “E Mode” is displayed. If not see section 8 and go through the “System Type” programming



## Controller Programming Quick Guide

- To enter the program, push the MENU button. This will bring up the screen we will refer to as the “main menu display”.



“Main menu” display

- Push the ARROW button to highlight the “Date Time” icon. The highlight appears as a box around the icon. Push the SET button. The “Date and Time” screen is now displayed.

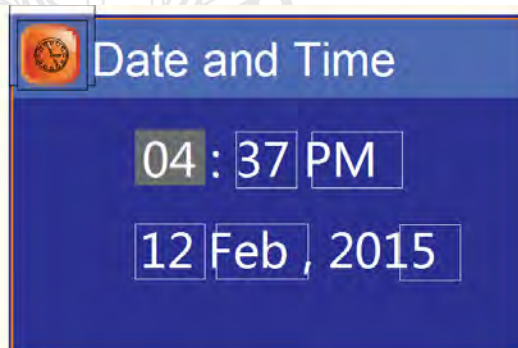

- The number highlighted can be changed. In above example “04” is highlighted. To change this number, push the SET button and the highlighted box will start flashing. While the box is flashing, the ARROW keys can be used to adjust it. Once the setting is correct, push the SET button again and the box will stop flashing. To move to the next number use the ARROW keys.  
**NOTE: When the box is flashing, the number can be changed.** When the box is on steady, the arrow keys allow you to change to another number .

- Once the proper time and date has been entered and the highlight box is on steady, push the MENU button to return to the main menu screen.

**NOTE: After two minutes of no activity on the programming buttons, the controller will automatically return to the “Main display” screen.**

Controller Programming Quick Guide



“Main menu” screen

- At the “main menu” screen move the highlight box to “System Settings” and press the SET button. The “system settings” screen will appear. NOTE: The most popular softener system type is “E” mode”. The “E” mode screen has six icons. If the screen below does not appear, go to section 8, “system settings”.

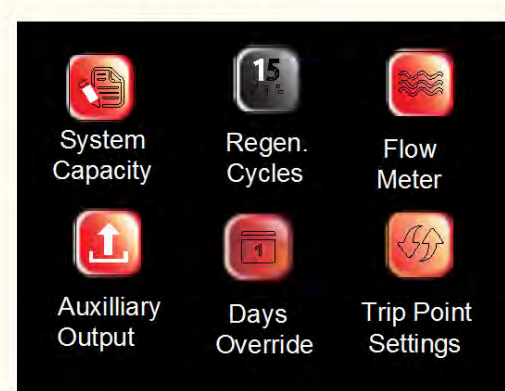

“System settings” screen

- Highlight the “system capacity” icon and push the SET button. The “system capacity” screen is displayed. Now the gallons capacity calculated at the beginning of this section is added to the program. In this screen one of the digits is highlighted. To change the number , push the SET button and it will start flashing. Once it is flashing, use the ARROW buttons to change the number. Push the SET button once the correct number is entered.

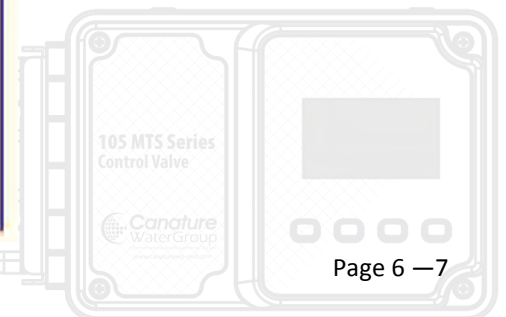
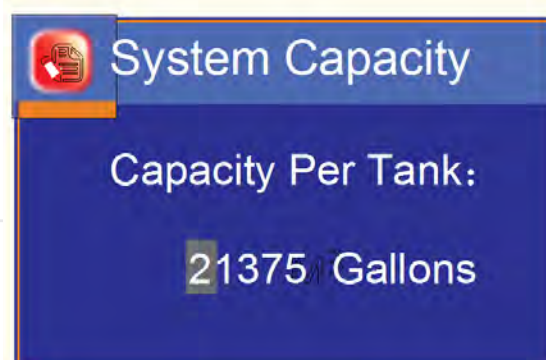

**Piping Inspection / Soaking Media Beds****Section 6.3**

Before starting up the system, check and confirm the following:

- Ensure system piping is correct (inlet to the valve inlet, outlet to the valve outlet, etc.) and all connections are complete, (see installation drawing). Sampling points are required before and after each unit to confirm the units are operating as intended.
- When piping is rigid, confirm flex connections are between the control valve and the piping and that there are vacuum breakers to protect the mineral tanks.
- Ensure that all of the **manual isolation and by-pass valves are closed** prior to start up
- Confirm valve has the correct drain line flow control and the drain line has a proper air gap.
- Brine line is connected to the softener with water in the brine tank (at least 2 " above the salt grid plate). Confirm the brine tank over flow is piped properly to drain.
- Confirm the meter cable is correctly in the meter slot on the outlet pipe adapter.
- Check all electrical connections and ensure that they are correct and complete.
- Once inspection is complete, manually advance the valve into backwash position. To do this on the 105 valve, push and release the "Set " button on the control valve.
- Once the control valve moves into the backwash position, unplug the control valve. This ensures the valve will stay in the backwash position, allowing slow filling of the tank from the bottom up. Dial on the side of the 105 has an arrow to indicate valve position.
- Partially open the inlet isolation valve. This will allow the unit to **SLOWLY** fill with water.
- When the unit is full, water will begin to trickle out through the drain. ***If the unit is filled too quickly, the media could be blown out, and may damage the internal distribution of the unit.*** Once full, close the inlet valve.
- Allow the unit to stand for 1-2 hours once the tank is full to fully saturate the media bed with water. The tanks may of already been filled with water when the media was first loaded (see section 5) and if so the media should already be fully saturated.

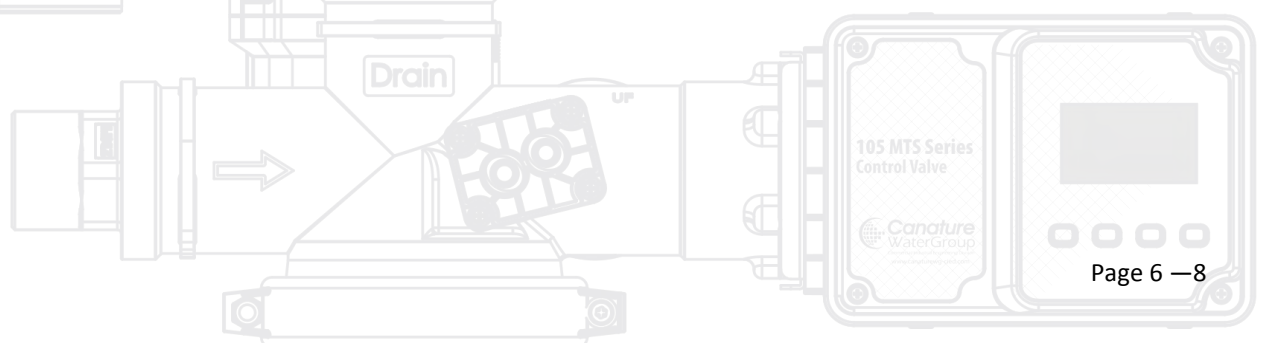



## Regenerating The System

## Section 6.4

- Once the media is fully saturated, the actual unit regeneration can occur. With the unit still in the backwash position, slowly start opening the inlet isolation valve. If the unit still has any air inside, it will sputter out. Constantly check the drain water and ensure only fines from the media bed is being backwashed out. If the drain water contains more than fines, reduce the backwash flowrate by throttling the inlet isolation valve. Any traces of air in the media bed can result in backwashing the media out. If this is happening, close the inlet isolation valve and allow the media to soak a little longer. Later, gradually fully open the inlet isolation valve. The backwash flow controller will limit the flow to drain. Allow the unit to backwash until the waste water clears up and there is no colour or fines still being removed. This process may take 20 minutes or more. Once completed, close the inlet isolation valve.
- With the inlet still closed, plug the unit back in. The valve may cycle back to the home position. If so initiate a regeneration again by pressing the SET button on the valve.
- Check all steps in the regeneration cycles and confirm the system is operating as intended.
- Ensure that in the brine draw cycle, brine is being drawn from the brine tank. If you continually see air bubbles in the brine line, recheck the brine tank connections and ensure they are properly sealed. Confirm the brine tank safety float is not restricted from moving .
- In the brine tank refill position, confirm the brine tank is being refilled properly. Confirm the brine tank safety float is not restricted from moving and operating properly.
- Upon completion of the steps above, the unit outlet isolation valves are **slowly** opened.
- The system bypass valve should then be closed. The system and piping should now be properly flushed. After this the system is now ready for normal service operation.
- Test the service water and confirm the system is operating properly.

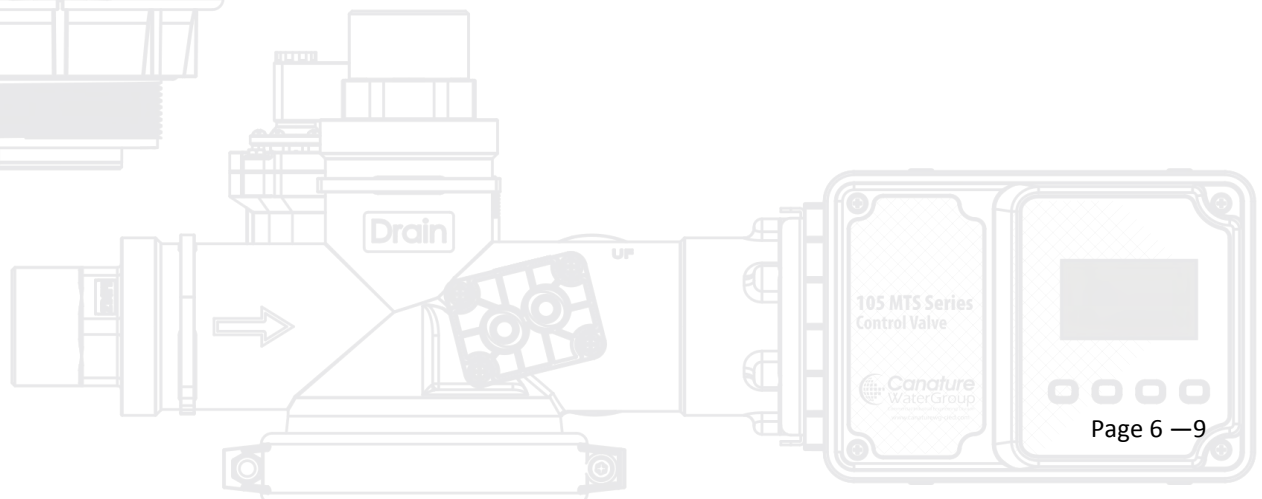

**Operating Conditions**

**Section 7.0**

For correct operation of the softener system, the minimum water pressure recommended is 30 psig, (206 kPa), in order for valve to operate effectively. **\*Caution: Water pressure is not to exceed 100 psig, (690 kPa), water temperature is not to exceed 100 °F, (38 °C), and the unit can not be subjected to freezing conditions.**

The manual bypass valve must always be closed and the manual inlet and outlet isolation valves open except during maintenance of the equipment.

**Cycle Operation**

**Section 7.1**

The current position of the control valve can be confirmed by the dial on the drive motor. Each cycle is indicated on the dial.

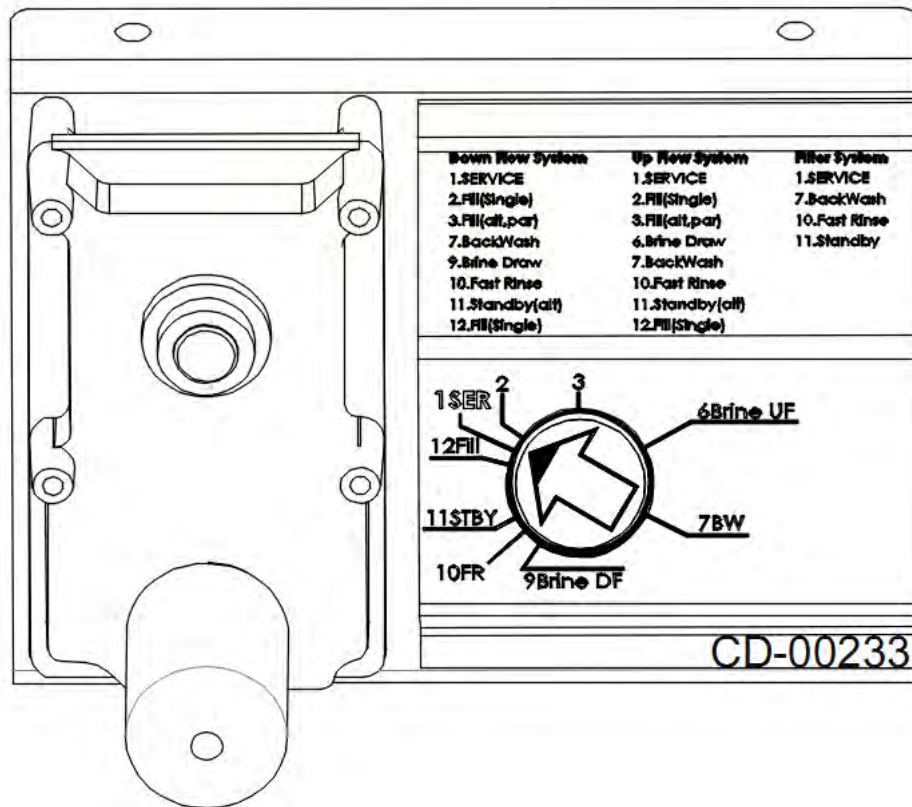

Service Position

Section 7.2

- During service, water is directed into the top of the tank by the control valve and flows downward through the resin media bed, through the support bed, into the distribution, and out to service. As the water flows through the softener media, the dissolved calcium and magnesium ions, (hardness minerals), is exchanged with sodium, (or potassium), on the exchange sites on the resin beads. As the duration of the service run increases, the softening resin slowly depletes, losing its ion exchange capacity, until the softening resin can no longer remove the hardness minerals. It is at this time that the regeneration of the softener is required in order to replenish the beds softening capacity. During regeneration, the hardness, (calcium and magnesium), that accumulated during the previous service run, are replaced on the resin by sodium, (or potassium). A brine solution rinsed down through the bed is the source of the replenishing sodium, (or potassium).

This is position #1 on the dial.

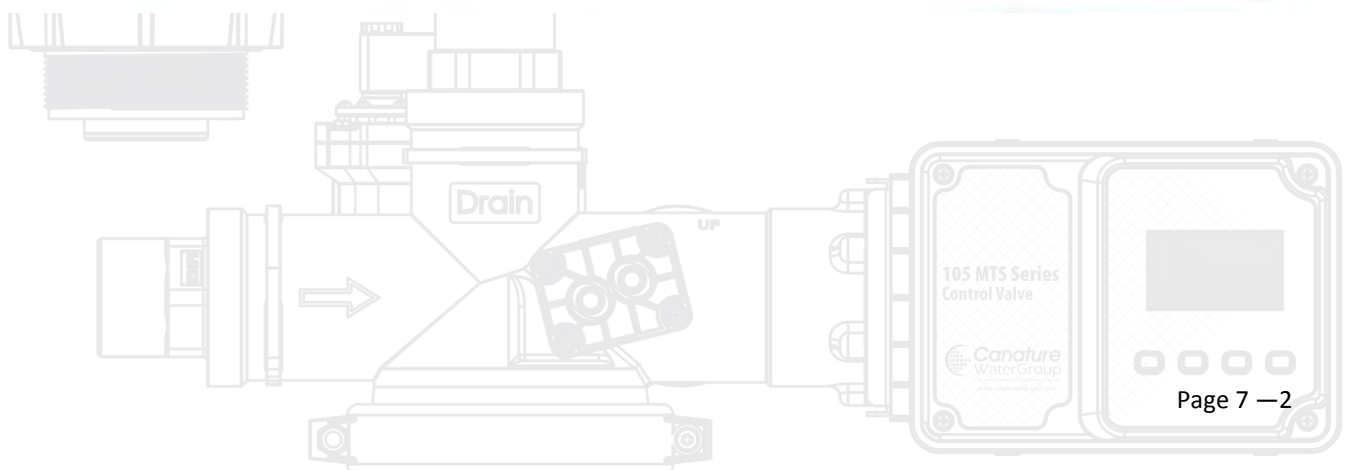
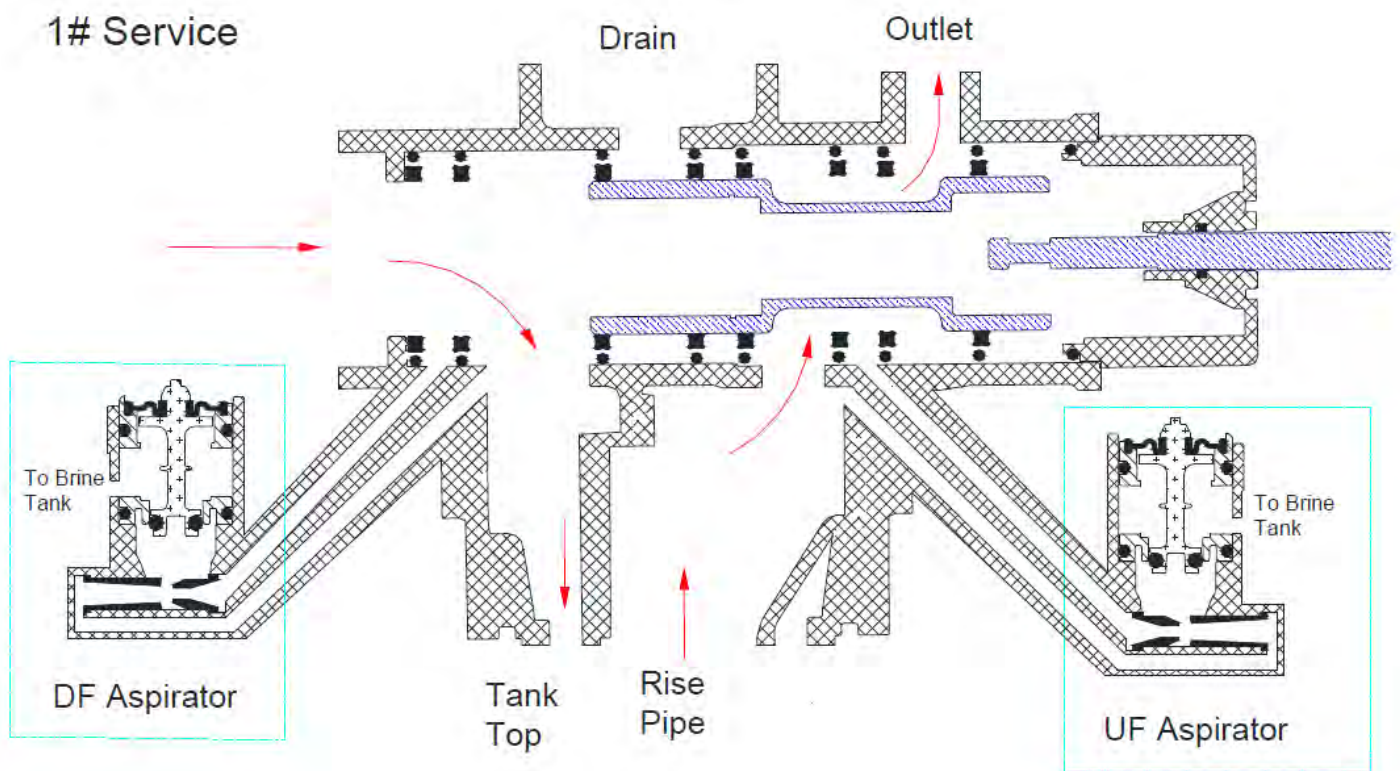



Service Position

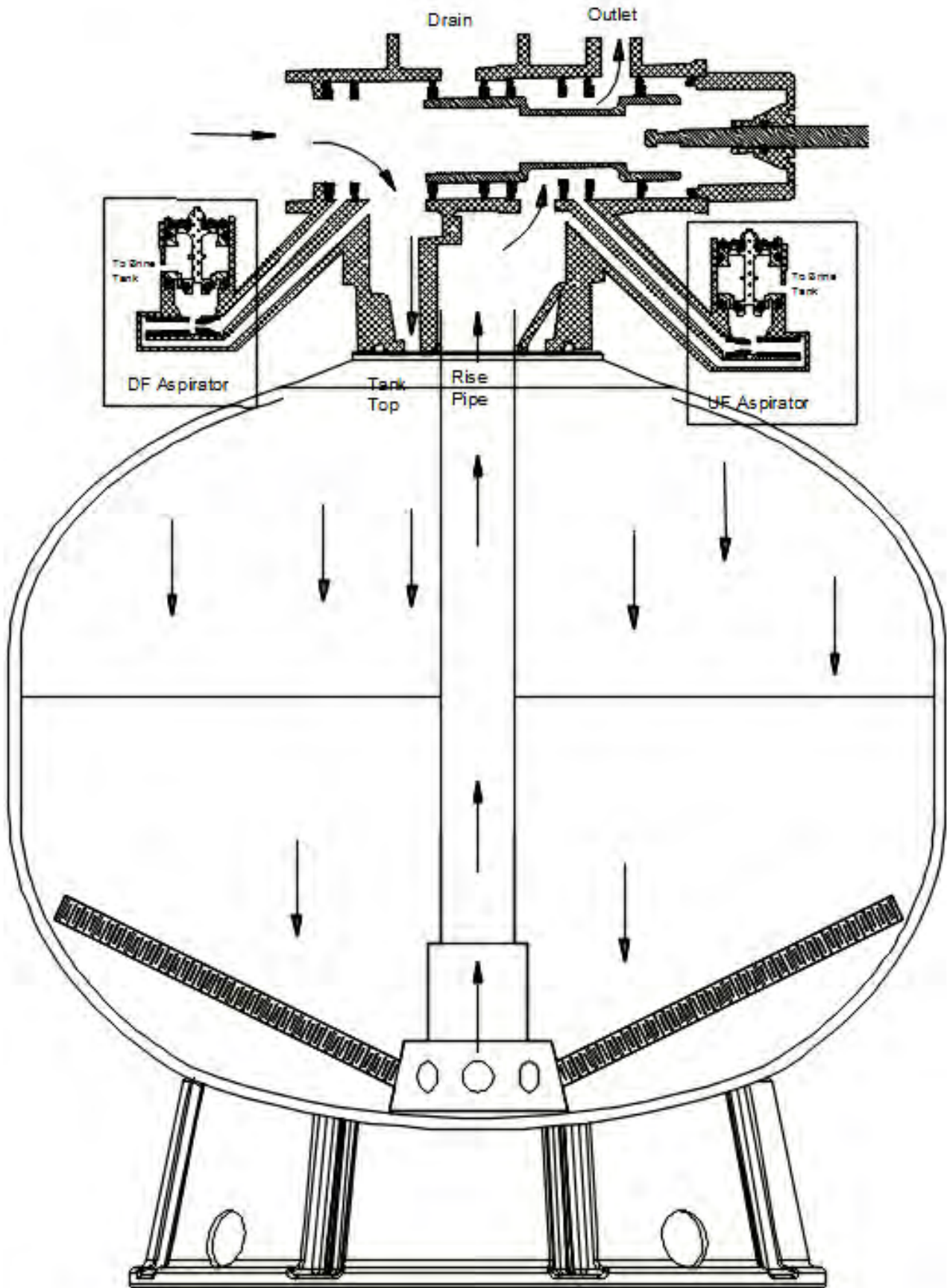

### Regeneration

### Section 7.3

The regeneration procedure is performed automatically by the softener after the cycle controller is started. Each regeneration cycle consists of four steps. For down flow regeneration, the cycles are #1 backwash, #2 brine draw / slow rinse, #3 fast rinse, and #4 brine tank refill.

### Backwash Position

### Section 7.4

During backwash, water is directed down the riser tube, out the bottom hub and laterals, then upwards through the softener resin and out to drain. This expands the media bed, releasing any trapped particles, and cleans it thoroughly. The standard backwash cycle is usually been factory pre-set to take place for 9 or 10 minutes. This is position #7 on the dial.

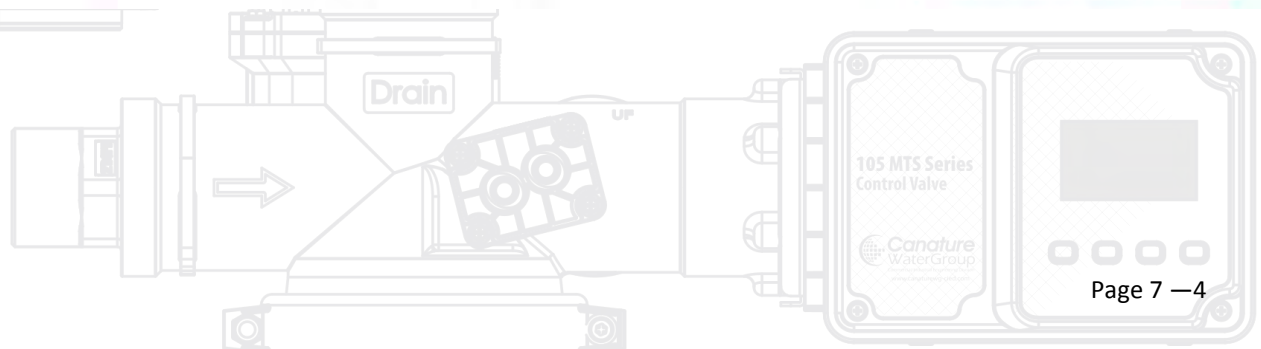
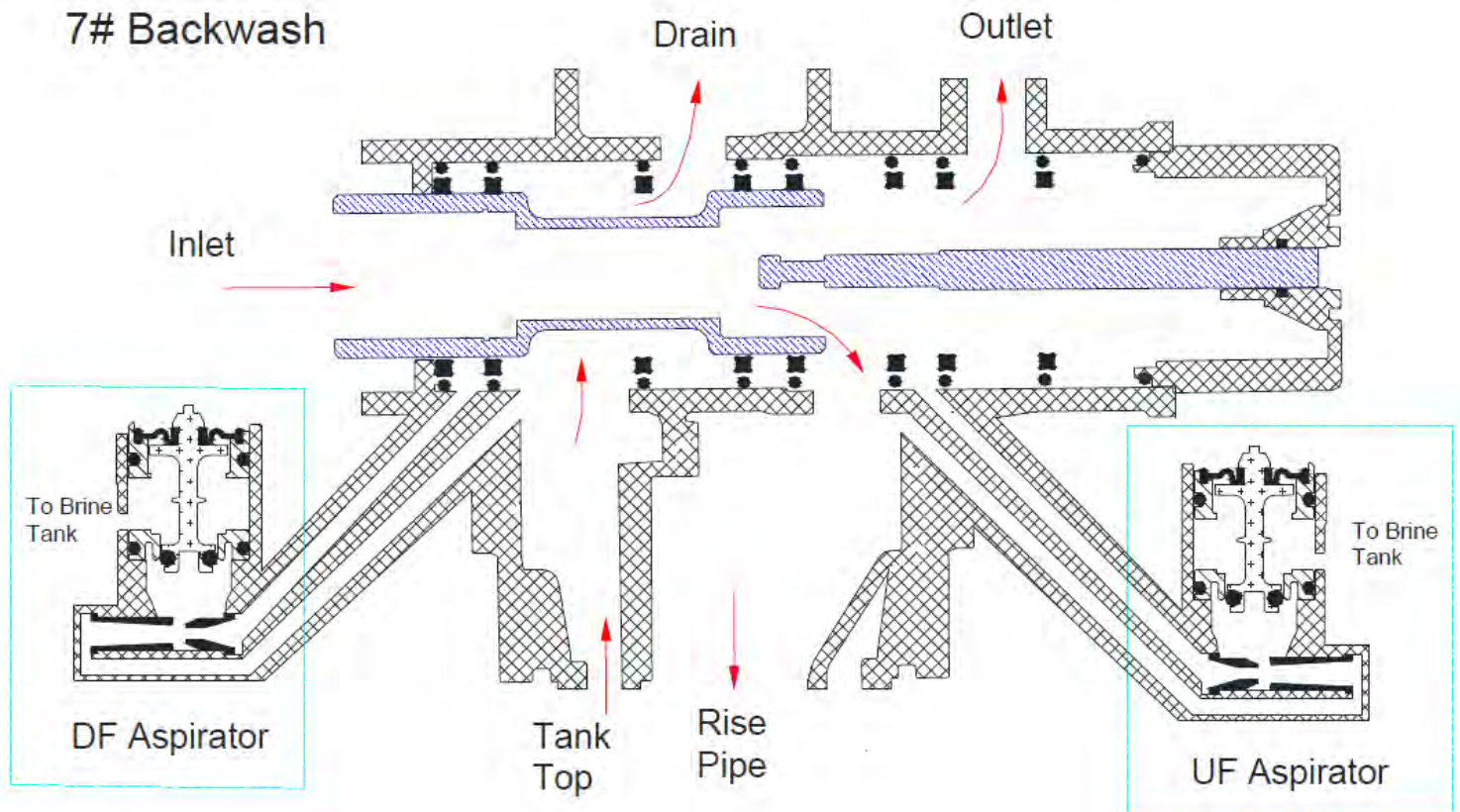



Backwash Position

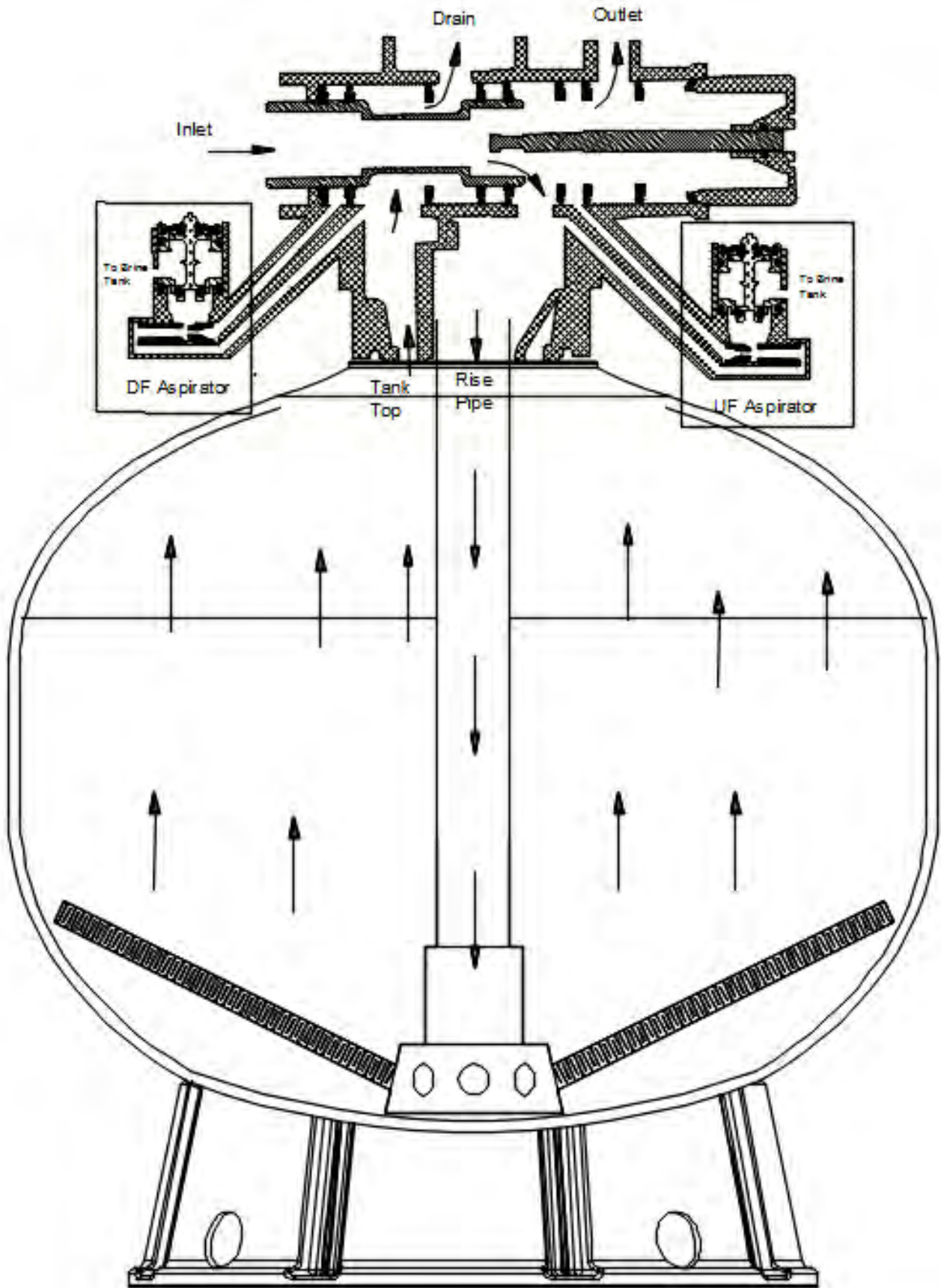



**Brine Draw / Slow Rinse Position**

**Section 7.5**

The brine draw / slow rinse is actually two cycles that occur even though the control valve piston does not move during this time. The brine valve is open during these cycles.

The first part of the cycle is the brine draw. Water from the valve flows through the through the injector, (or aspirator), assembly. This water flow creates a vacuum which results in drawing in a brine solution from the brine tank. This mixed water / brine solution then flows through the media bed and out to drain.

For a “**down flow**” unit, the brine enters from the top of the unit, DOWN through the media bed, into the hub and laterals, up the riser tube & out to drain. This is position #9 on the dial.

**9# DF Brine Draw**

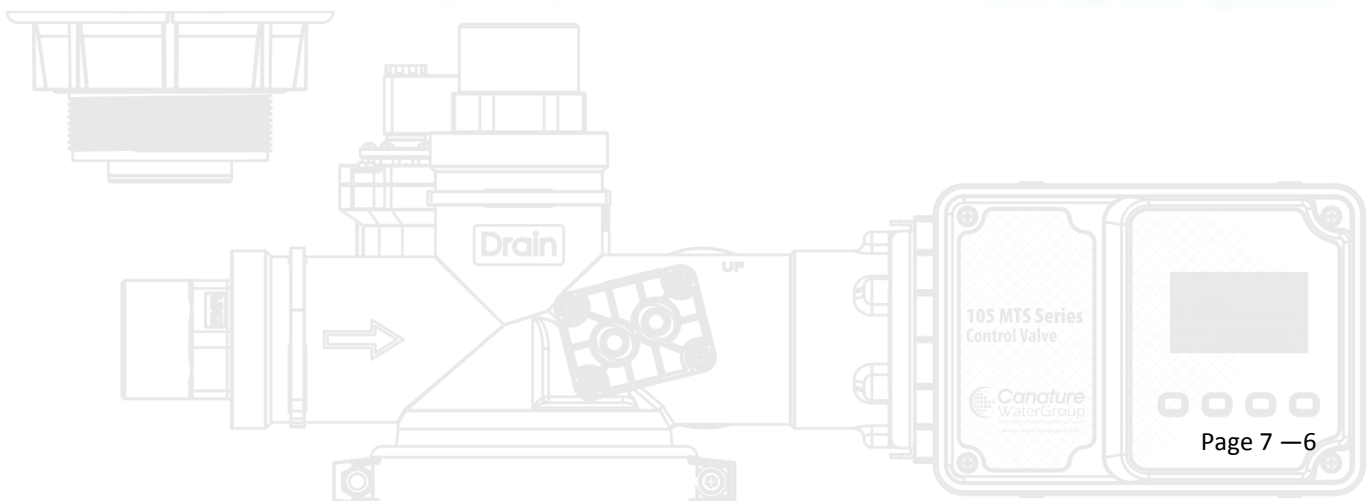
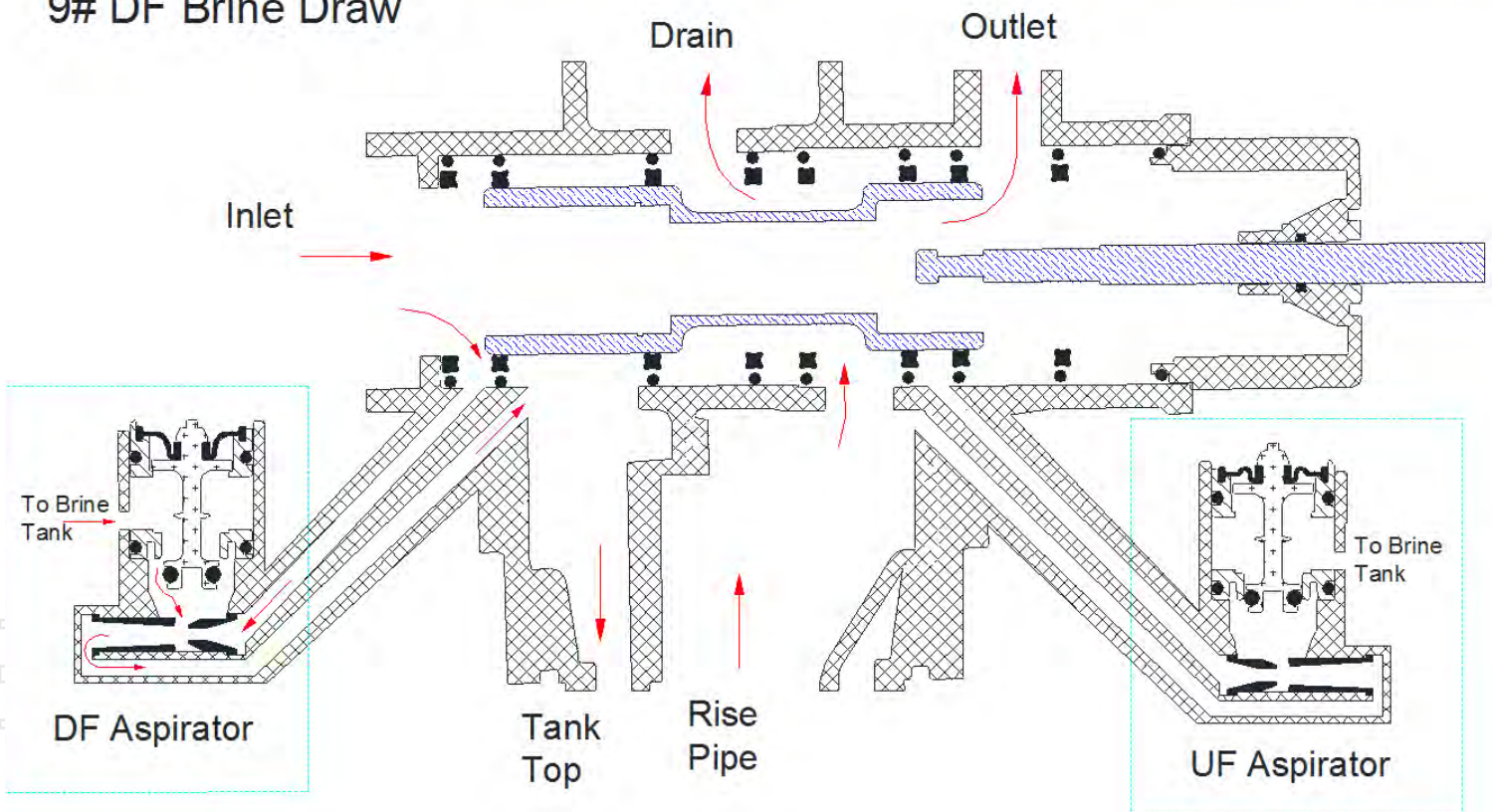

Brine Draw / Slow Rinse Position

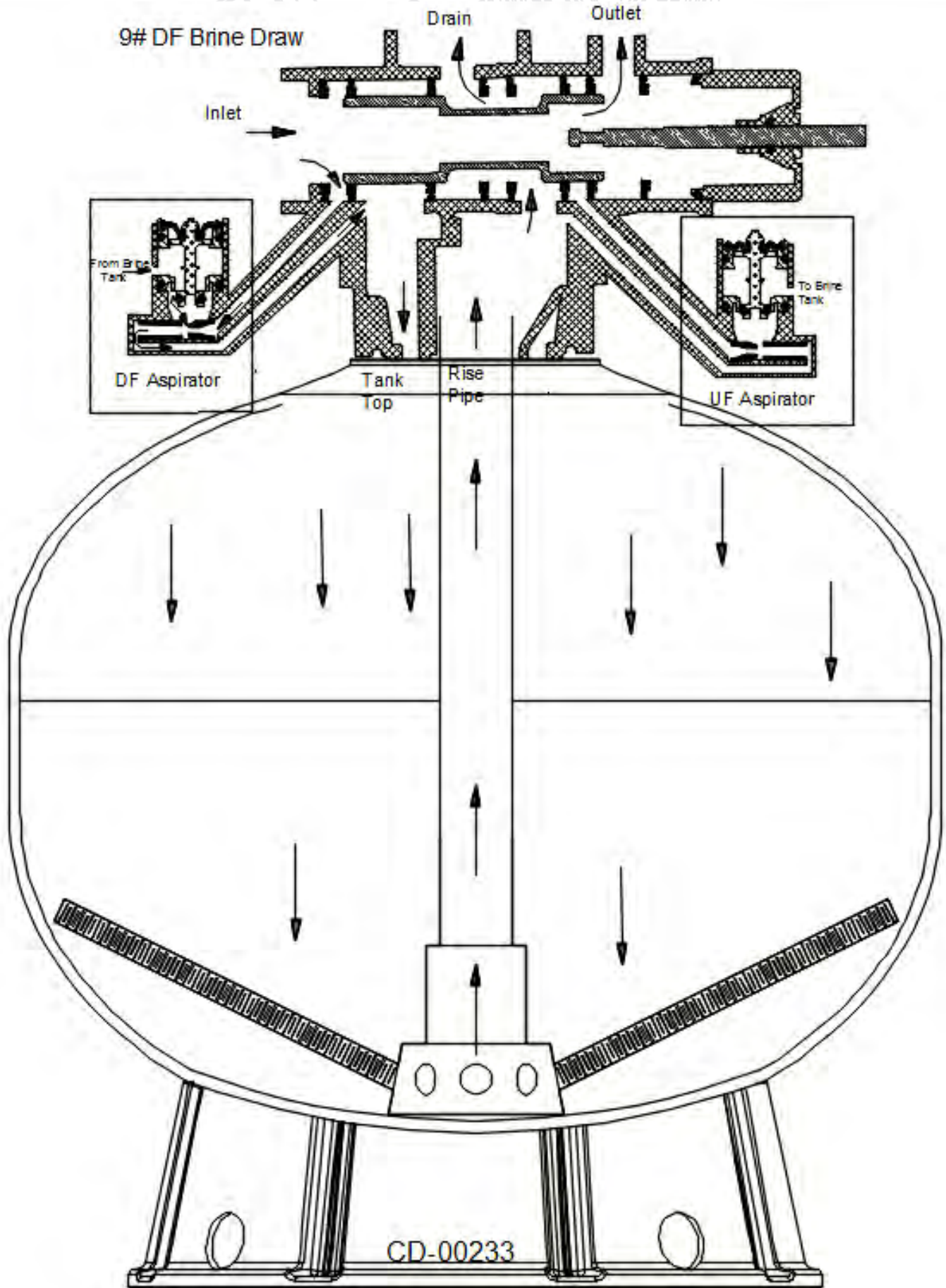



The softeners continue to draw brine until the brine supply is exhausted. On most systems, the brine supply is stopped by the air check.

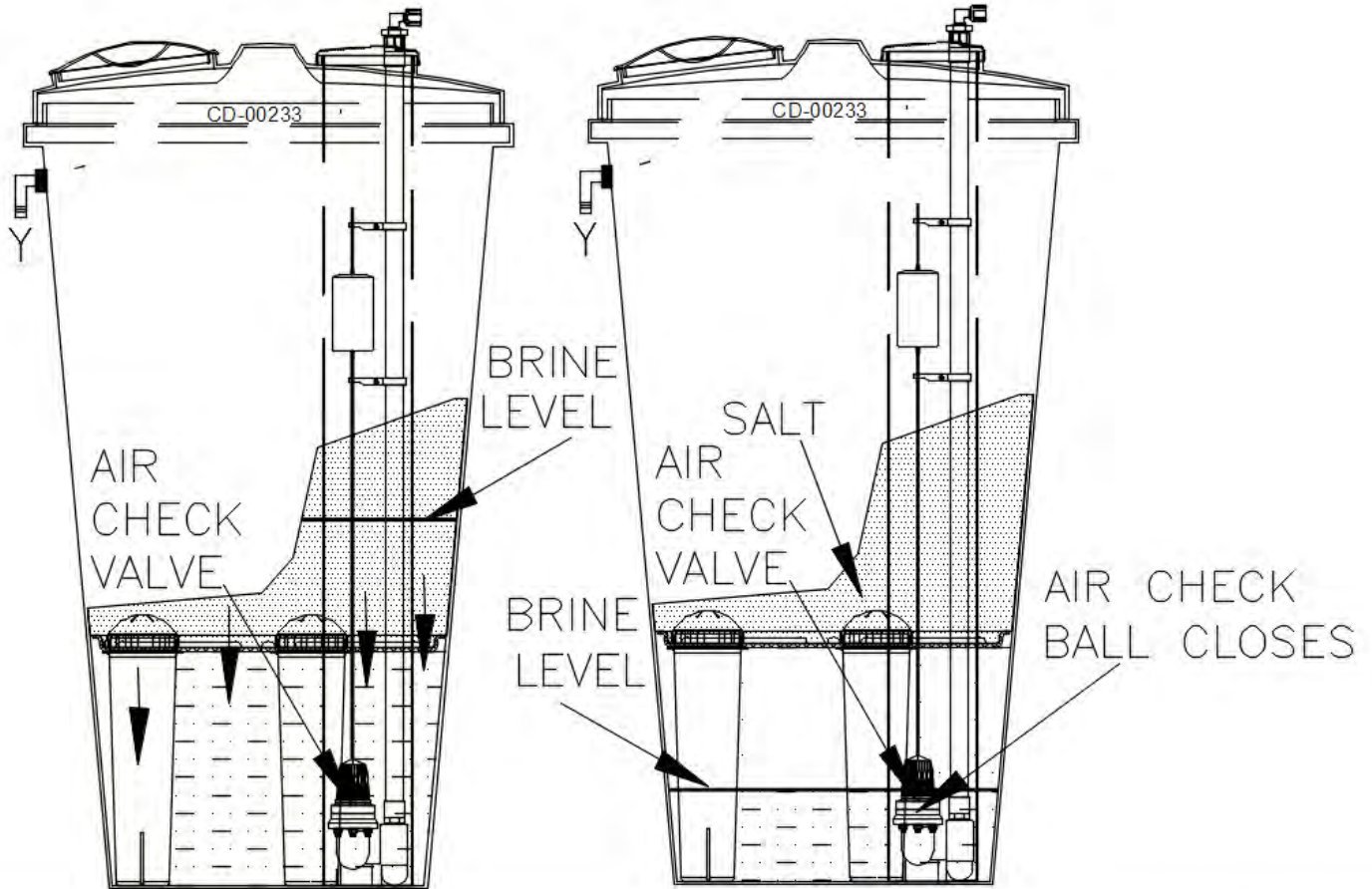

Control valve drawing brine from the brine tank in brine draw cycle.

The level of the brine drops until the ball of the air check stops the flow of brine .

When the flow of brine is stopped by the air check, the brine draw cycle ends and the slow rinse cycle begins. The actual control valve piston does not move. There is now a low flow rate that will slowly push the brine through the media, which will continue replenish the resin bed.

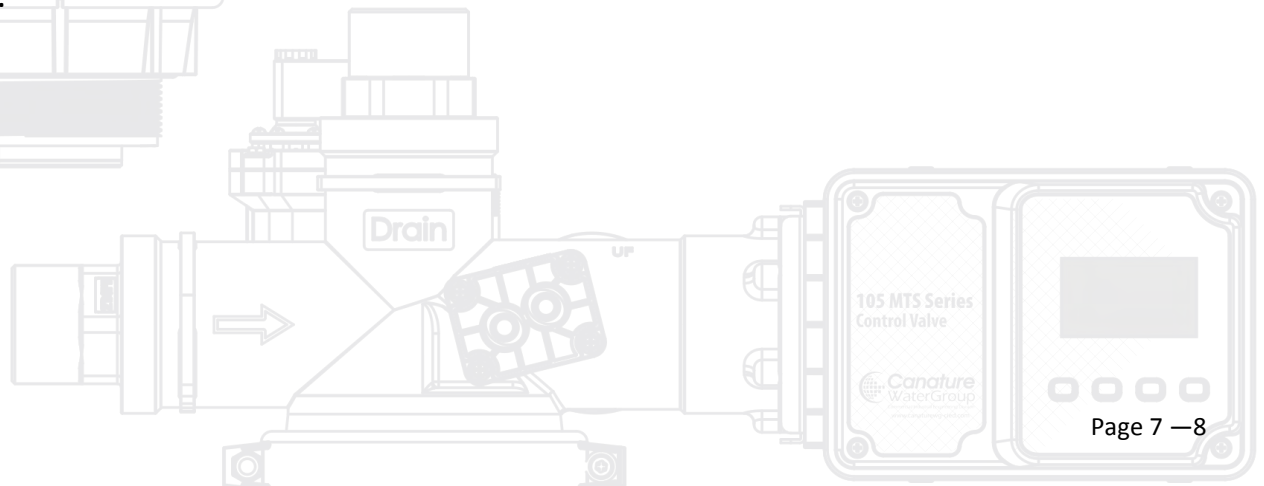



Rinse Position

Section 7.6

During rinse, water is directed downwards through the softener and out to drain. This reconsolidates the media bed and rinses any remaining brine in the media bed to drain. The flow rate to drain is controlled by the drain line flow control.

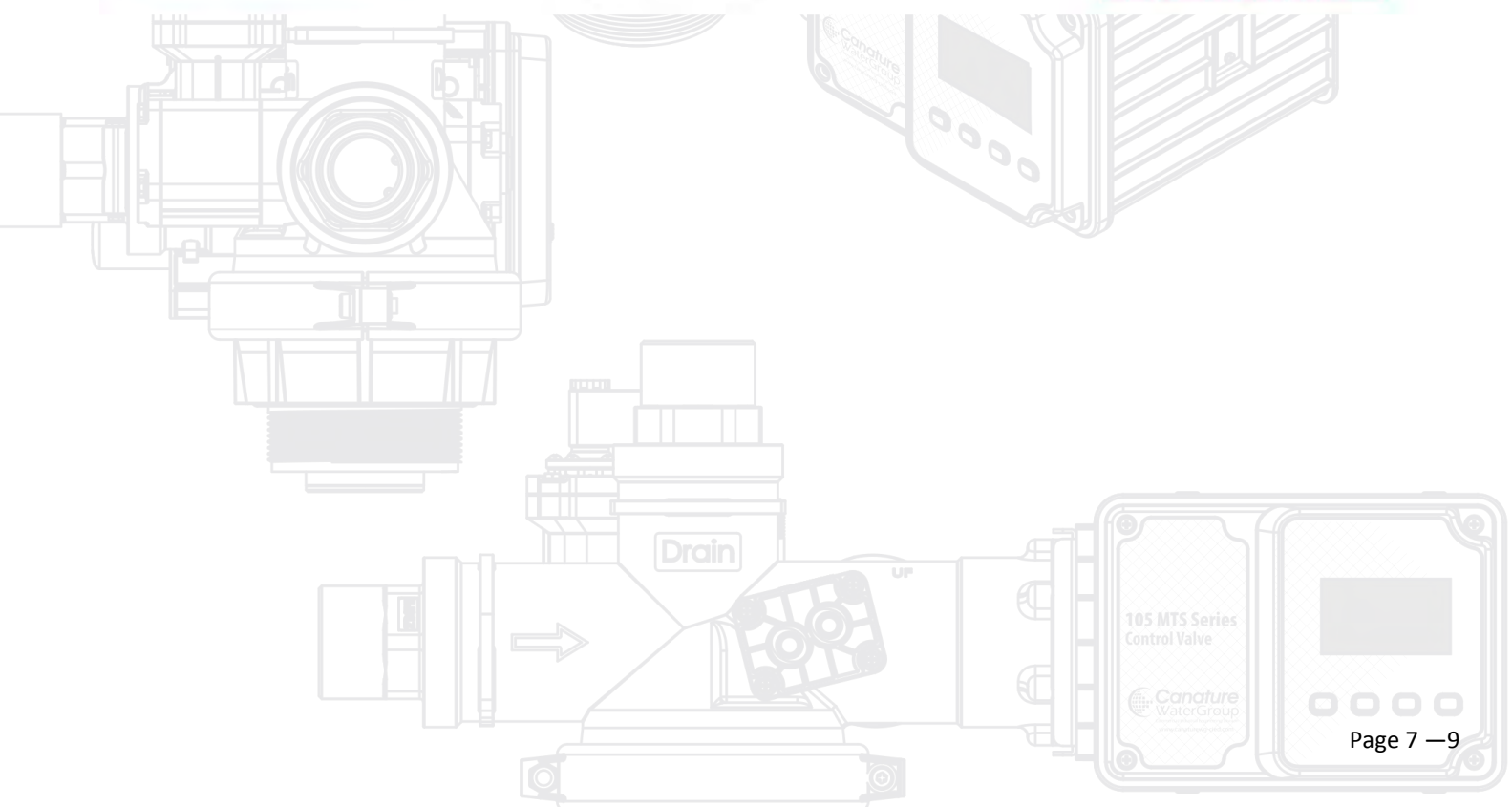
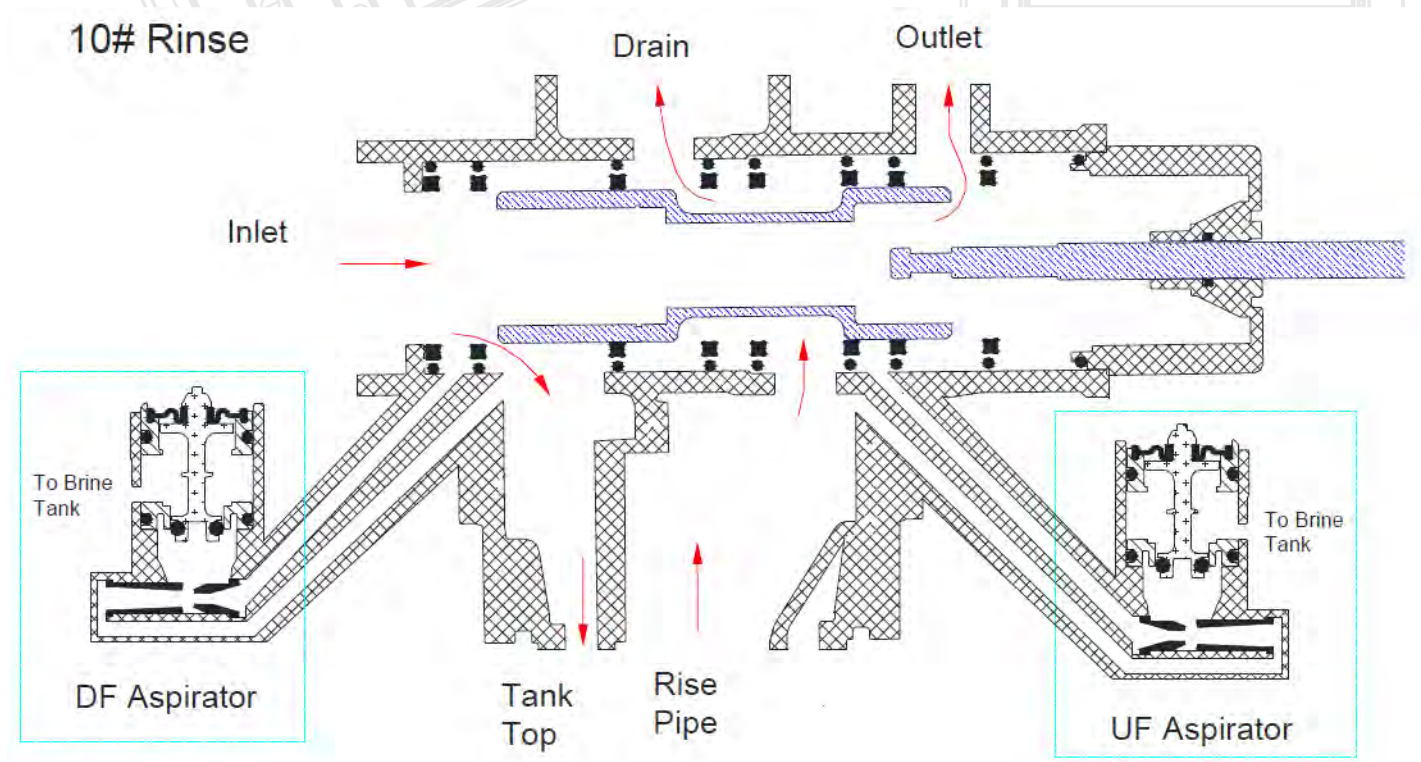

Rinse Position

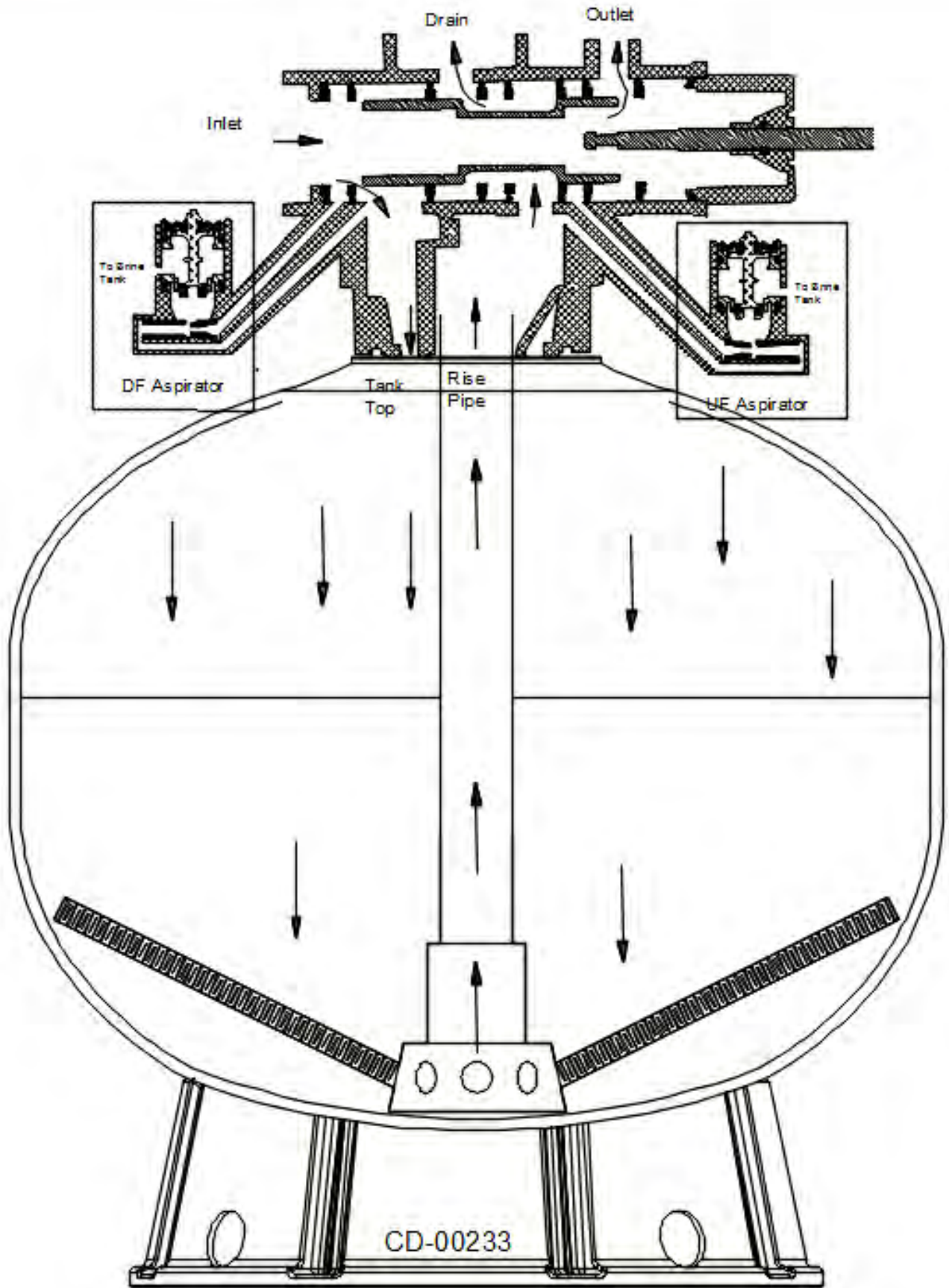



**Brine Tank Refill**

**Section 7.7**

The brine tank refill cycle will direct a predetermined amount of water back into the brine tank for the next regeneration cycle. The refill water flows through the injector, (aspirator), through the brine valve and out to the brine tank. The flow rate to the brine tank is regulated by a flow control orifice. By adjusting the refill time, the volume of water to the brine tank is fixed. This is position # 12 on the dial.

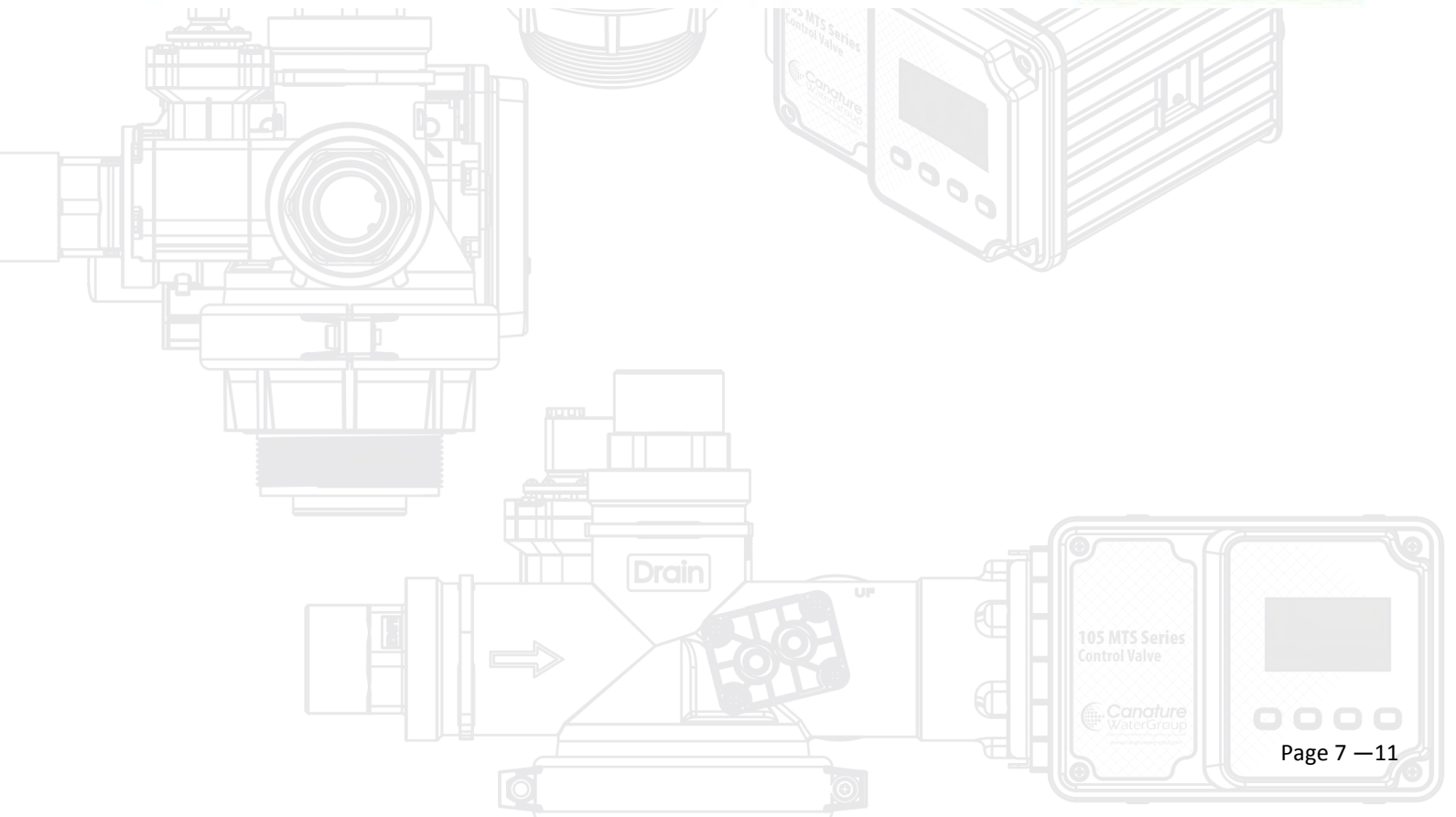
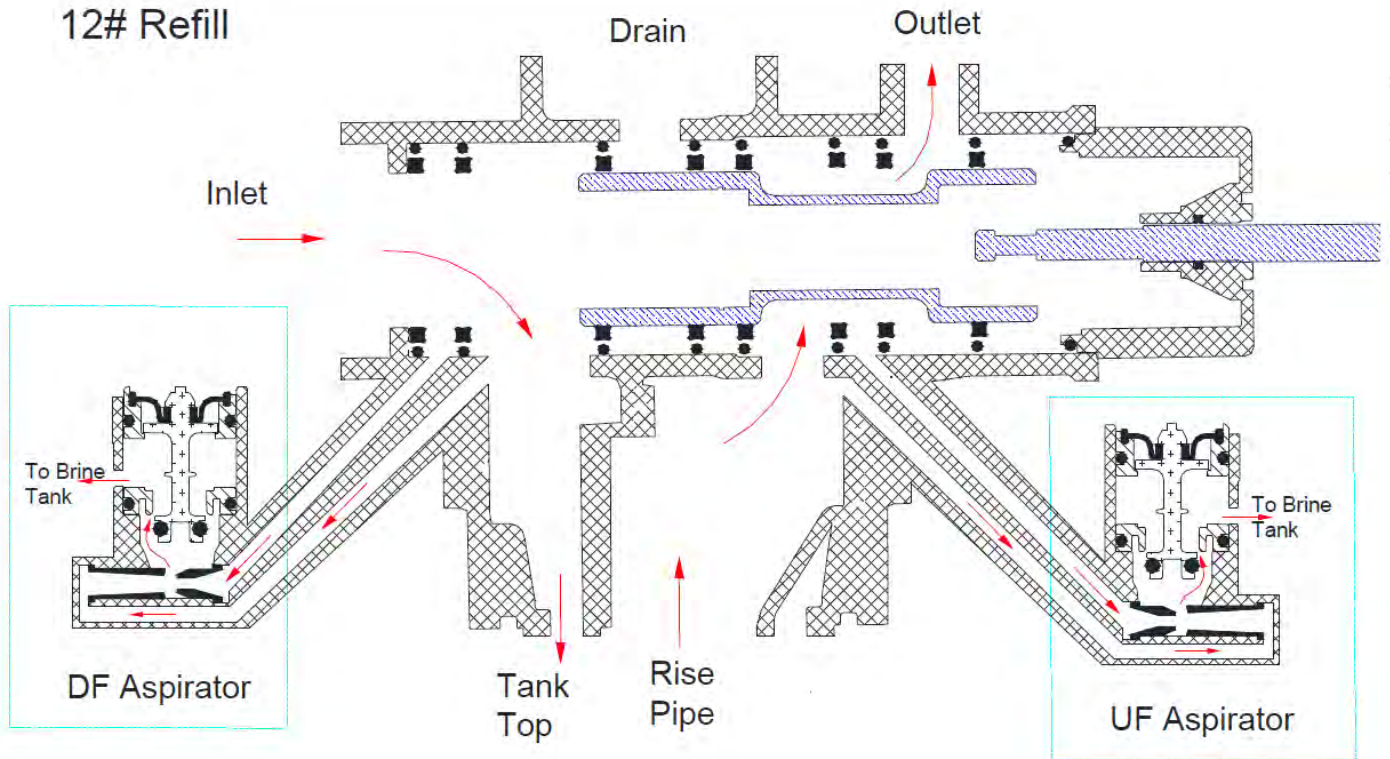



# Programming

## MTS(B) Controller Overview

### Section 8.0

- The MTS master controller is designed to operate a system with up to eight 105 softener slave valves or up to sixteen filter slave valves.
- From the MTS display screens, the entire system and of each individual slave valve unit can be monitored and controlled. All programming is facilitated through the controller.



- The MTS “Main screen” display shows the general overall status of the complete system.

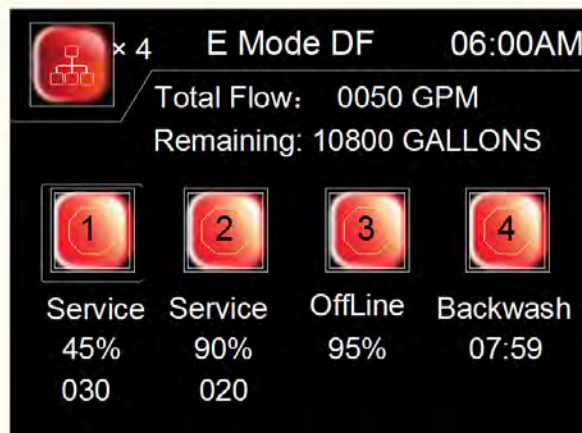

“Main display” screen

CD-00233

This screen shows the number of media tanks and each unit’s current status. This will be referred to as the “**main display**”. The status of each unit is displayed including service, offline, in regeneration, or drop (communication issue). If the unit is in regeneration, the display will show the cycle the unit is in and the time remaining. Other information displayed includes the system type, the number slave units, system flowrate, remaining capacity and time of day.

Key Pad Configuration

Section 8.1

There are four push buttons on the 105 control valve.

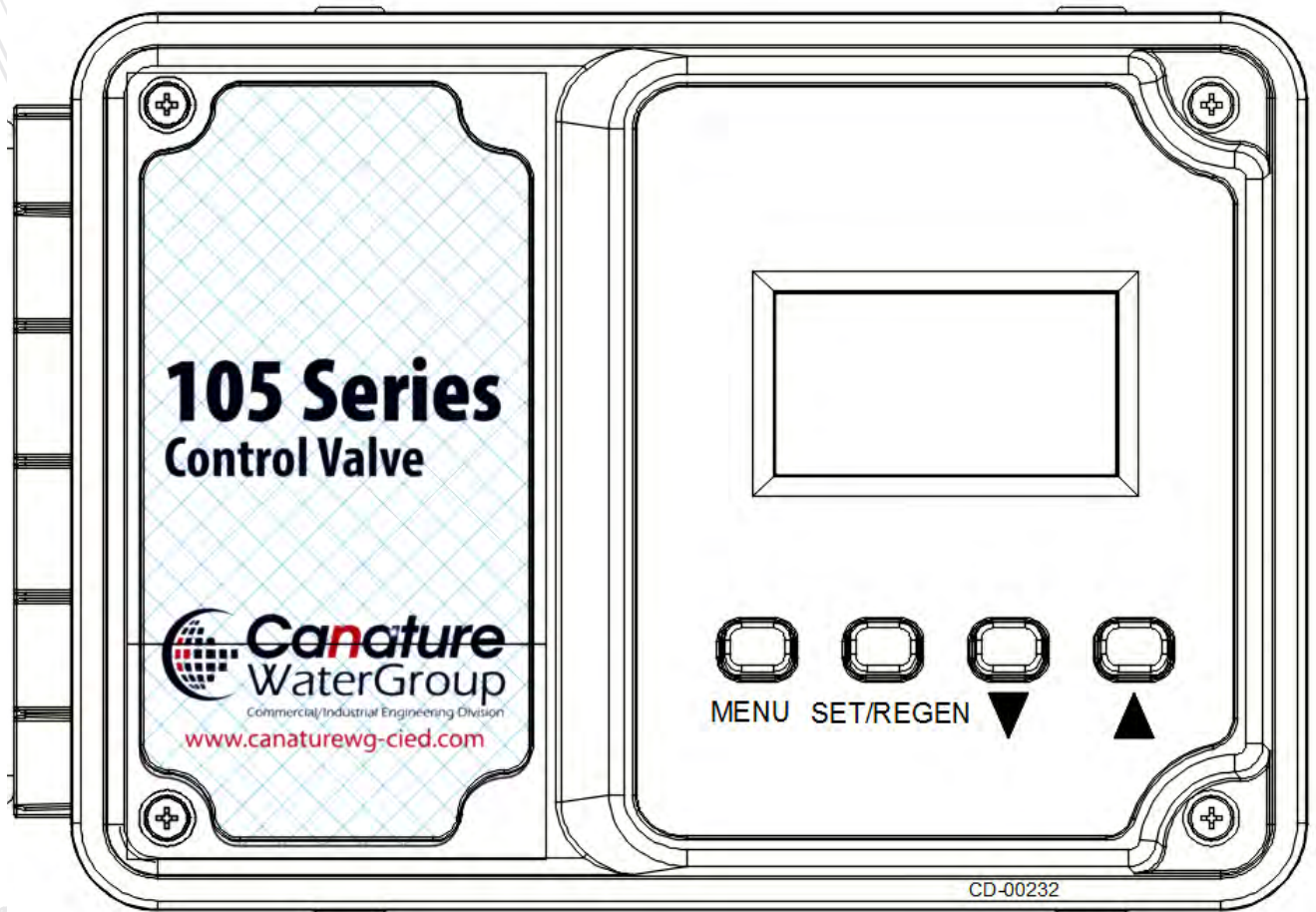

**Note: MENU, SET and ARROWS will be referred to indicate which button is required to be pushed.**

MENU "□": This function is to enter the basic setup information required at the time of installation, or back to previous page.

SET "■": this function is to accept the values if changed and advance the next item in the menu.

+/- "▲ ▼": These buttons are used to scroll the icon bar in the menu, and increase or decrease the value of the settings while in the programming mode.



## Programming

### Section 8.2

#### MTS(B) Controller System Types

-There are four main system types.

##### 1- E Mode

-E mode is used for most softener systems. It is a parallel service flow system. Each unit has a meter and counts down independently. The E mode allows for the responsive flow system configuration. With this system, the MTS controller monitors the total system flow rate. Based on this flow rate, the MTS controller automatically adjusts the number of units on line. At low system flow rates, the controller will reduce the number of units on line to avoid channeling. At higher flowrates, the controller will increase the number of units on line to minimize the pressure drop through the system. Compared to the standard parallel flow system, the responsive flow system greatly reduces the chance of multiple units requiring regeneration at the same time.

##### 2- D Mode

- D mode is a softener parallel service flow system with one unit in standby or regeneration at all times. Each softener has a meter and counts down independently.

##### 3- TA Mode

- TA mode is a twin alternating softener system. The system has one common flow meter on the system outlet.

##### 4- F Mode

- F mode is used for most filter systems. It is a parallel service flow system. The system regenerates in series. This means when regeneration starts, One tank will regenerate at a time and once the first tank completes it's regeneration, the next unit will go into regeneration. This continues until every one of the filters have regenerated.



Programming

System Operation

Section 8.3

Main

English & Metric format as below example, RED ones are attached as US gallons unit.

Depending upon the four different system types, the screens shown below indicates the

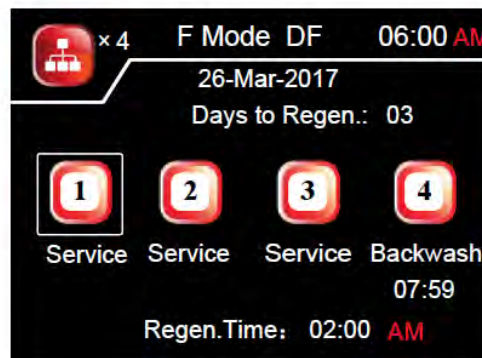
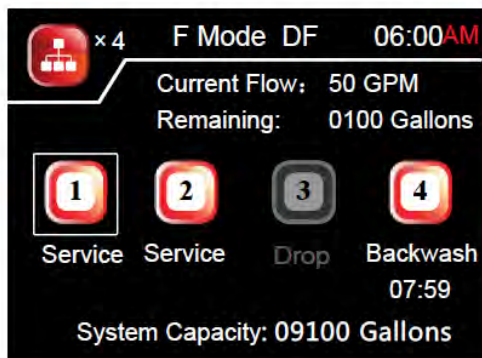
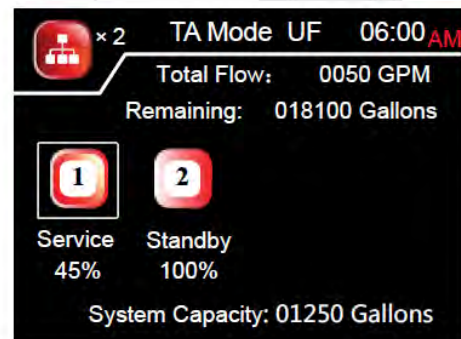
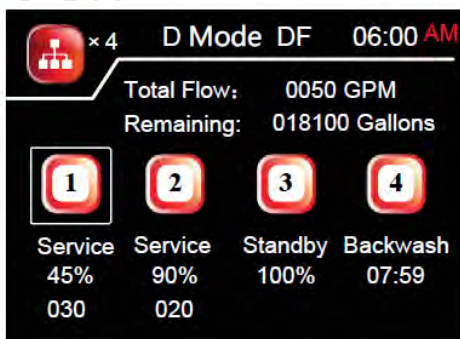
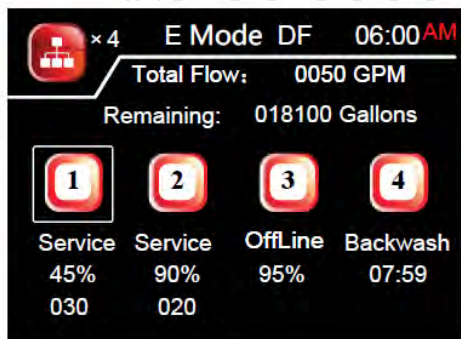

status of the system entire system .

Information on the “Main” screen includes the following:

- The system and valve types, quantity of tanks in the system, and current time
- System total flow rate and remaining of system capacity.
- During regeneration, the actual cycle the unit is in as well as the time remaining for that cycle.
- Depending upon the system types, additional information is displayed.
  - E mode & D mode: In service -Remaining percentage and flow rate.
  - In standby - Remaining percentage.
  - TA mode: (In Service and Standby) Remaining percentage;
  - TA and F mode: Complete system setting capacity
  - F mode: Days remaining (if clock initiated), or volume (If meter initiated).

## Programming

## Main Menu Settings

## Section 8.4

2. Main Menu Setting:

When in programming mode, generally, the “MENU” key moves back one step ( screen) . The “SET” key moves down on step (screen). The “SET” key also allows the settings in the program to be modified. By pushing the “SET” key, the item that is highlighted will start flashing. When it is flashing, that item may be modified by using the up or down keys. Once the setting is correct, pushing the “SET” key to stop the item flashing. Now by using the up or down keys, the next item can be highlighted.

At “main display” page, press "MENU" key to go to “Main menu”. Use the "UP/DOWN" keys to move cursor. Use the "SET" key has two functions. “SET” is used to confirm information, or to start the blink , "UP/DOWN" to adjust value and "SET" key enter complete.

Meanwhile "MENU" key can back to Main display page at any setting page.

1) Date/Time: Set current date and time, operation same as above procedures;

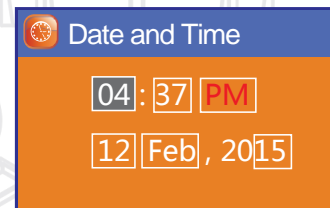

2) Region and Language:

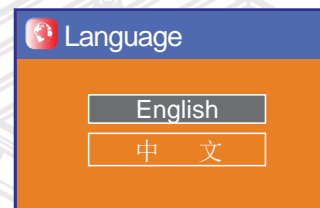
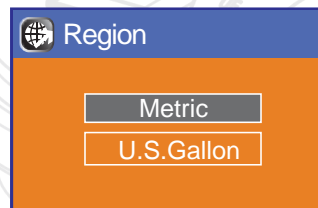
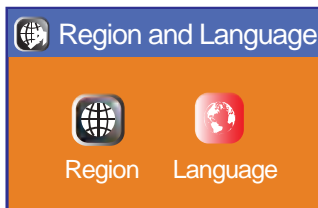

3) System Type:

To change “System Type” a security code password “1234” is required.

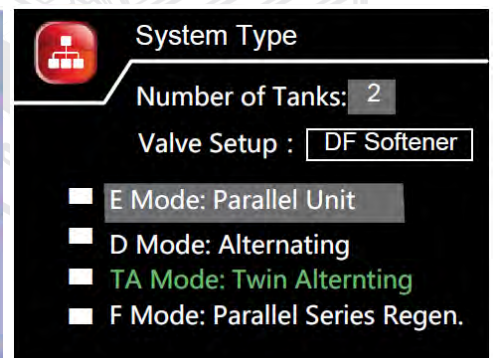
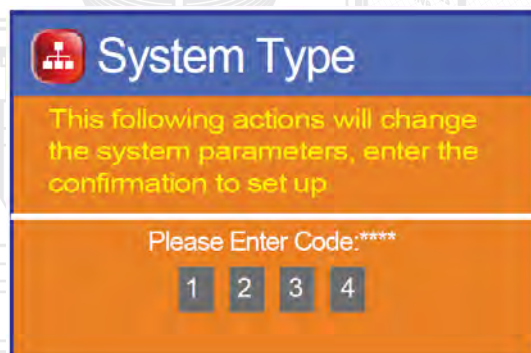

Number of tanks setting: 2~8, permanent 2 for the TA Mode system only.

Valve Setup: Choose proper valve configurations .

System Mode: Current mode display is highlighted in green. Choose one from four modes. The most common for MTS softeners is “E” mode.

Programming

Valve Setup: Choose one from 3 valve types as right.

System Mode: Current mode display in green color, choose one from four modes, reconfirmation page followed if you change;

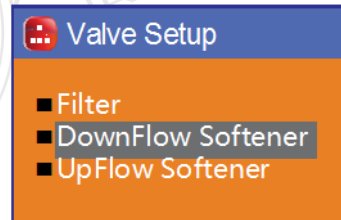

4) System setting: At current system mode, setting system service and regeneration parameter.

E mode system

F mode system

D/TA mode system

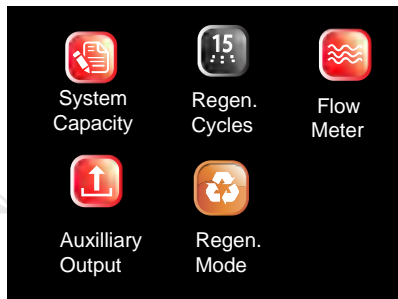
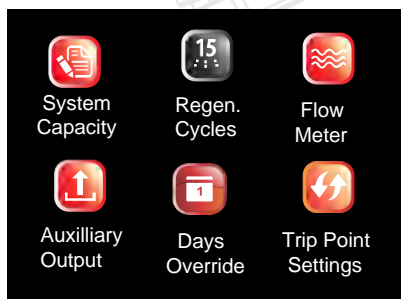

System Capacity: Normally displays in 10000 us gallons or defaults to 10M<sup>3</sup> in metric.

Water volume between adjacent regeneration setting. For one meter system (TA or F mode) it is whole system capacity setting, For D and E mode, setup capacity per tank;

TA or F

D or E System mode

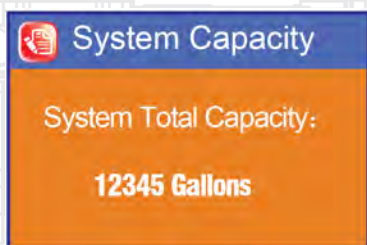

Regeneration Cycles: Cycles are displayed in minutes. Cycle lengths vary with the unit capacity and system type.

Set each cycles duration depend on sequence of the valve type, For example: 105DF Regen. cycles as right;

Pause cycle is available for E and F system only, default 0.0 Hrs, it is a duration after regeneration is complete.

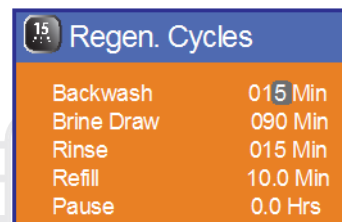



- Flow Meter Setting: default as 1.5" internal turbine. This setting is used for all 105 valves with an internal meter.
- For the Generic meter, the "K" factor is used for the particular meter being used. The "K" factor can be found in sensor supplier's brochure.
- NOTE: The generic meter must supply a "hall" effect signal (square wave)

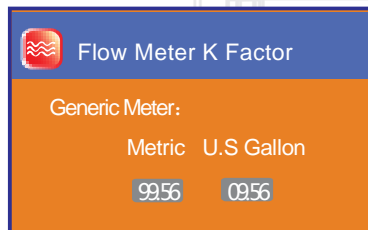
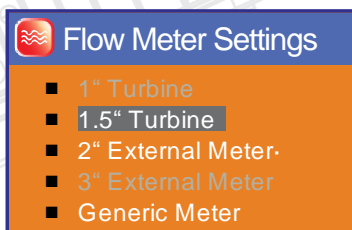

Auxiliary outputs setting: default as set off all

Slave Auxiliary outputs 1#: 12VDC <200mA

Master Auxiliary outputs 1#: Dry contact signal, NO.

and 2# is same as 1#.

Slave Auxiliary outputs Setting: Each slave PCB 's 1# output status as

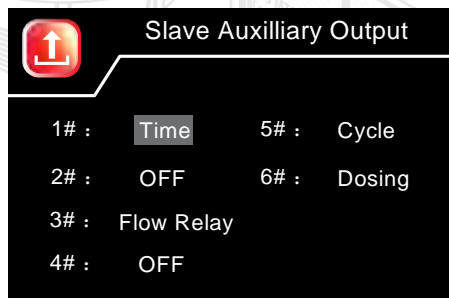

Description: Set off: Not available

Time Based: default as below, adjustment range: 0~99mins

Cycle Based: Output switch simultaneously upon the cycles activation which following the valve type, default all cycles were closed.

Batch dosing: default value is below at metric unit, 1000 Gallons (10~9990) 、 10.0Mins (0.1~99.9) is for U.S. gallon unit.

Flow Relay: default flow rate 10L/M (1~99) ; 10 gpm (1~99) ;

The image displays four screenshots of the 105 MTS Controller interface for 'Auxilliary Output 2#':

- Time:** Delay after Regen. initiated: 10 Mins; Activated duration: 05 Mins.
- Dosing:** Every volume of system treated water: 1000 Gallons; Activated duration: 10.0 Mins.
- Cycles:** A list of cycles with checkboxes: Service (unchecked), Backwash (checked), Brine + Slow Rinse (checked), Fast Rinse (unchecked), Refill (unchecked), Standby (unchecked).
- Flow relay:** Flow Relay Set Point: 10 GPM.

A fifth screenshot on the left shows the 'Auxilliary Output 2#' menu with options: Set OFF, Time Based, Cycle Based, Batch Dosing, and Flow Relay.

Master auxiliary outputs 1#:

The screenshot shows the 'Master Output 1#' settings menu with the following options:

- Set OFF
- Whole Regeneration
- System Batch Dosing
- System Flow Relay

Description: Set off: Not available

Whole Regeneration: A System regen. but not slave valve regen. only

System Batch dosing: Based on System total flow volume.

System Flow Relay: Based on System total flow rate.

Two screenshots of the 'Master Output 1#' interface:

- System Batch Dosing:** Every volume of system treated water: 1000 Gallons; Activated duration: 10.0 Mins.
- System Flow Relay Set Point:** 10 GPM.

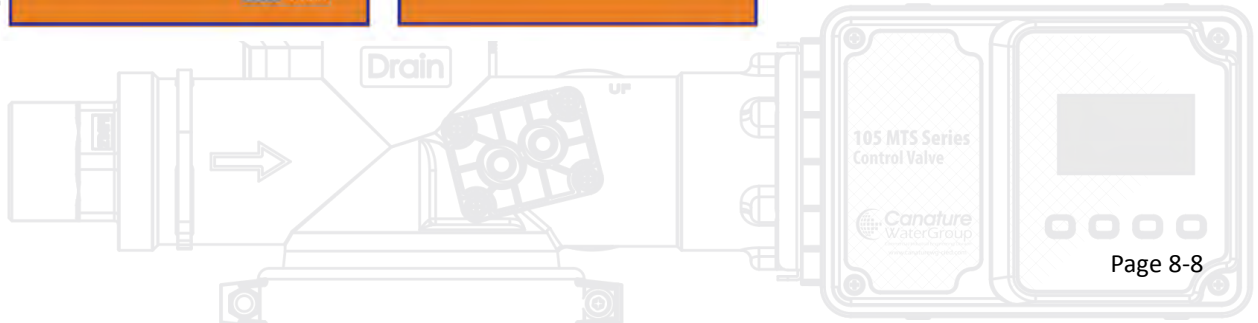

# Programming

Regeneration initiate Mode: default as Meter Delay

this is a setting for F system only

Days or/and regen. Time will be asked followed by the Days and Meter Override or Meter Delay mode setting

Further reserve setting will be done if Meter Delay or Meter Override was selected, default is Weekly Maximum:

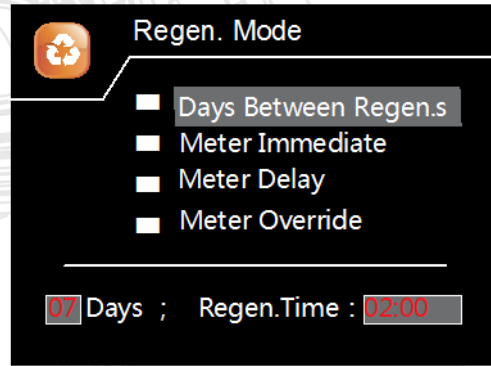

IF choose fixed percentage, adjustment range: 0~50%:

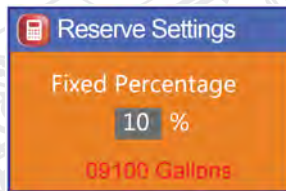

Standby tank setting:

D/TA systems only, to change the tank in service.

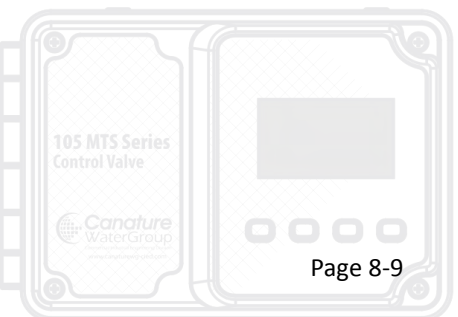
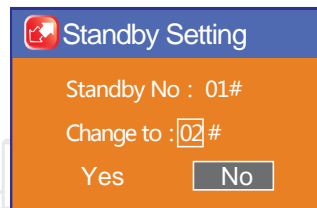



E System Type

Section 8.4.1

E-System

-The E system has all softeners on line. The system will only regenerate one softener time. Regeneration is based on capacity. The first unit to count down to the regeneration point will regenerate first.

-The responsive flow system monitors the total system flow rates. The main MTS controller will automatically adjust the number of units on line. As the required flow rate increases, the controller responds by adding additional units on line. When the flow rate decreases, the controller responds by reducing the units on line.

-The flow rate “set points” determines when the system requires additional units. The controller always has one unit on line. This “lead” unit will be the softener with the least capacity remaining. When additional units are required, the controller will look at the remaining capacities of the units currently off line and will choose the softener with the lowest remaining capacity. A password is required to access the set point screens (8888).

E-System With Responsive Flow Only (system default is off)

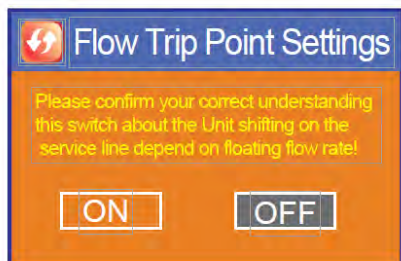

Days Override: (system default is off)

- Available on the E system only, the unit with the lowest capacity is regenerated.

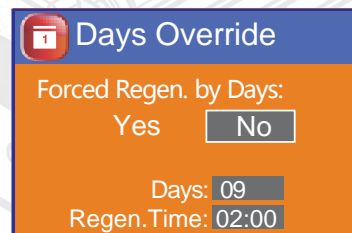

- Information: This is history information display of each tank in whole system about service and regeneration, it helpful to evaluate system running and parameter setting.

Note: At the "Main display" page, Same history information viewed by pressing "SET" key when cursor at the icon of Service or Standby tank.

**MTS Information Screens**

**Section 8.5**

This is history information display of each tank in whole system about service and regeneration, it helpful to evaluate system running and parameter setting.

Note: At the "Main display" page, Same history information viewed by pressing "SET" key when cursor at the icon of Service or Standby tank.

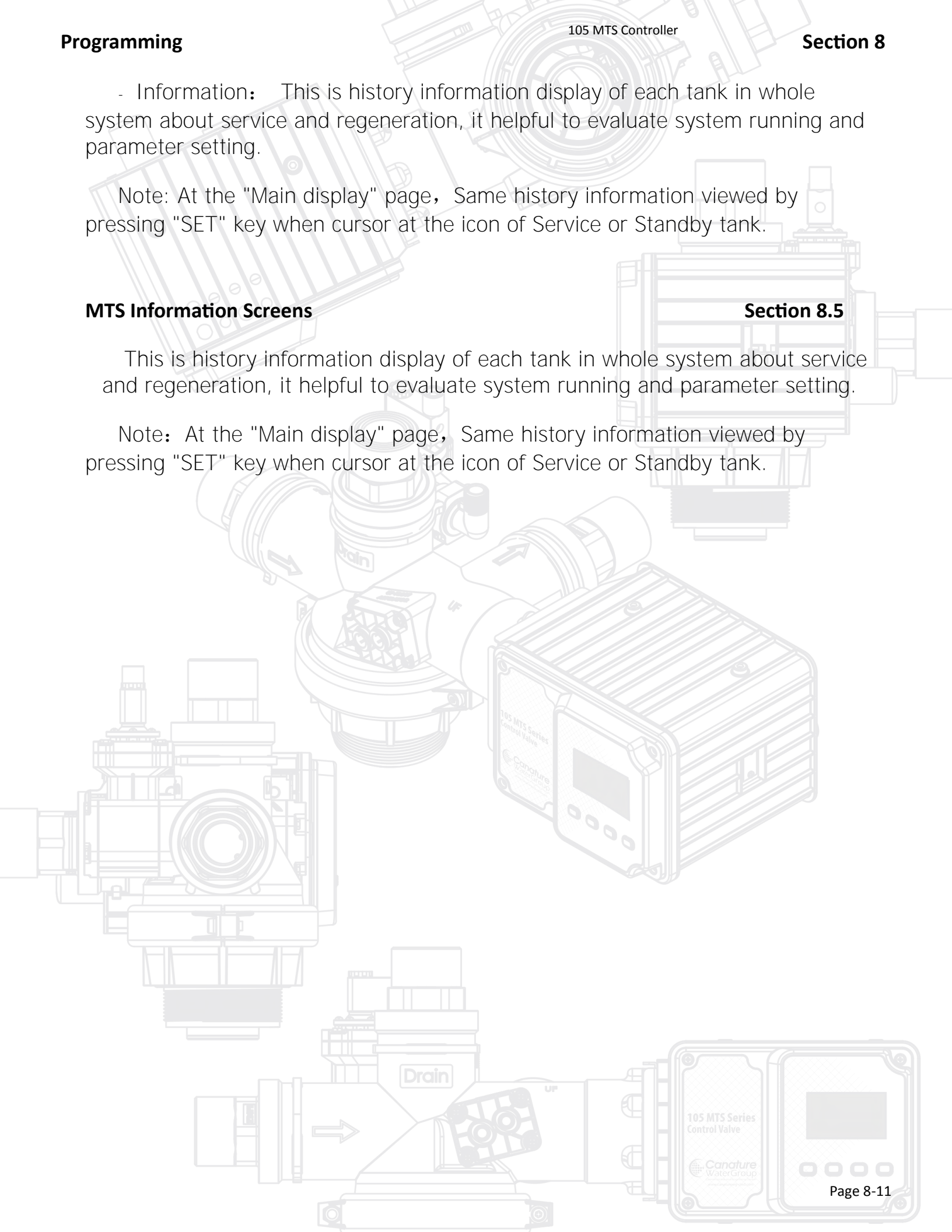

# Programming

Information Screens:

- These screens display the system operational history. The initial screen allows the specific unit to be inspected shown by ID of Tank. On this screen there are four areas that can be chosen.

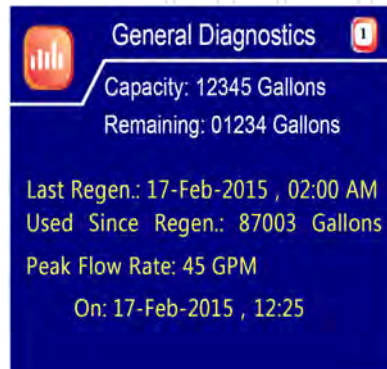
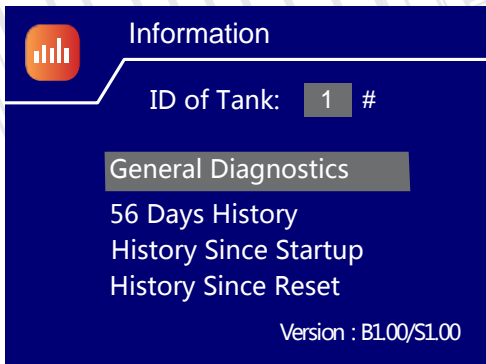

General Diagnostics displays general information on the specific unit chosen. These include remaining capacity, when the last regeneration occurred, volume used since the last regeneration, as well as peak flowrate.

56 Days History displays water usage over the past 56 days.

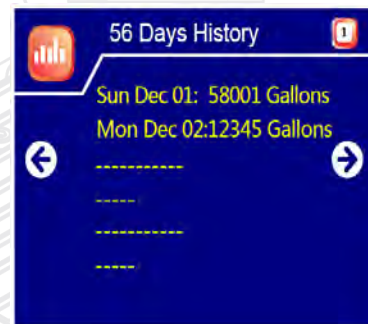

History Since Startup Information shown is the total system summarized history since the initial start up.



History Since Reset allows the summarized history to be reset and will display the values since the system was last reset. To reset the required confirmation code 1 2 3 4





History since startup and reset---need a "1234" password for each history record reset.

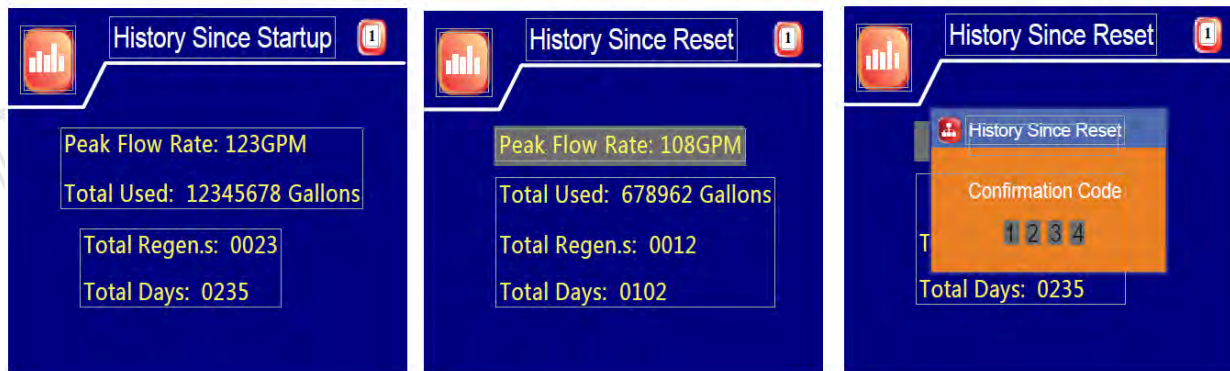

### Regeneration Screens

### Section 8.6

 At the "Main display" page, a detailed regenerating information can be viewed as right side when cursor at the icon of regenerating tank:

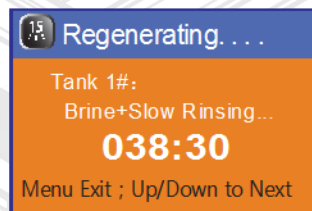
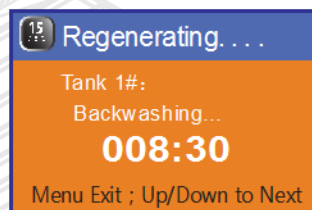

The cycles sequence follow by the valve type, and back to service or standby after regeneration finish. pressing "MENU" key to Exit from current regeneration, and "▲" or "▼" can skip to next cycle directly.

"SET" key on slave panel 3s can skip also.

Screen information:

Tank (valve) number#;

Countdown time of current Regen. cycle;

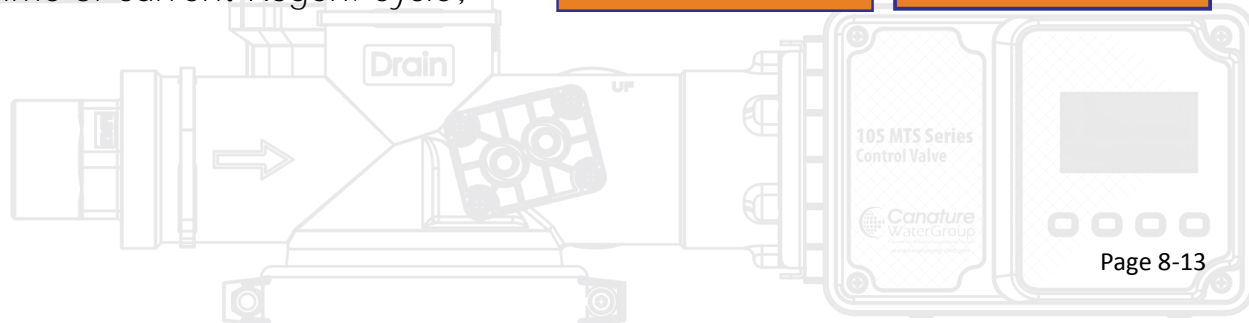
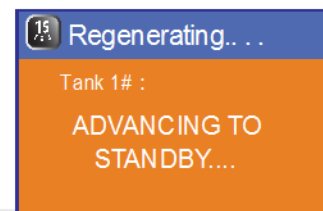
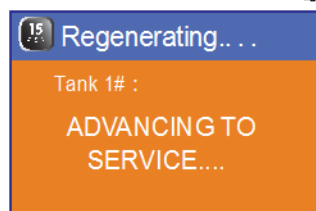

**Manually Initiating A Regeneration**

**Section 8.7**

**1** The controller must be at the "Main display" to manually initiate a regeneration. This is accomplished by first by highlighting the tank to be regenerated, then holding the "SET" key for 3 seconds until the "manual regeneration " screen appears. Using the up and down arrows enter "yes"

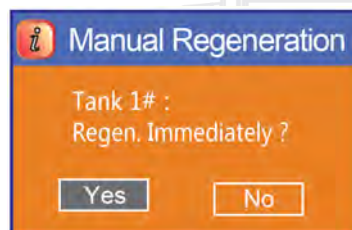
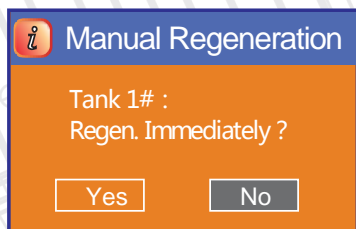

Same manual regeneration can be initiated on a slave valve by holding the "SET" key on panel for 3 seconds. Regeneration may also be initiated by a remote contact, if equipped.

**PCB Troubleshooting Error Codes**

**Section 8.8**

At "Main display" page, inactivated Gray color of the Tank icon caused by a bad communication cables or connection or wrong slave valve setup.

Alarm page and beeping as right:

E1: Check the micro switch cable or harness connection to PCB then plug power on again.

E2: Check all include slave PCB/ wire/motor and valve piston movement which can cause failure of positioning.

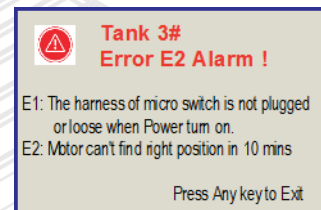

## General Maintenance

## Section 9.0

***Caution:*** To prevent personal injury, or damage to the system, properly relieve the system pressure before doing any servicing on the control valve, piping or on the media tank.

1. Turn off the water supply on both the inlet and the outlet piping to the control valve / unit.
2. Step the control valve through a complete regeneration cycle once to relieve the pressure inside. To do this push and hold the “SET/REGEN” button on the valve keypad. Once the valve moves into regeneration, the valve can be advanced through the regeneration cycles one at a time by pushing, (& briefly holding), the up or down arrow button. Make sure the valve is back in the service position when done.
3. Once the control valve is back to the service position, unplug the electrical power to the unit.
4. For any individual part identification, see section 10.

**General Tools Recommended**

Tools recommended to perform basic service on the 105 control valve are:

- Seal stuffer & puller, (70020033).
- Silicone grease, (1014081-8 oz tube).
- Anti seize compound (for Stainless to stainless bolt connections).
- 8 mm nut driver or socket with ratchet.
- 6 mm, 4 mm & 2.5 mm Allen wrenches.
- #2 Phillips screw driver.
- 2.4 mm (0.1”) wide flat screw driver.
- Large flat screw driver.
- Needle nose, channel lock & snap ring pliers.
- Wire hook or dental pick hook, (at least 12” long).
- Chain or strap wrench.
- If changing media, a wide mouth funnel #99004 and a media extractor kit #50040050 are recommended.



#99004

105 #50040050  
Control ValveCanature  
WaterGroup



**PCB / Drive Motor / Power Head Removal****Section 9.1**

**Caution:** To prevent personal injury, or damage to the system, properly relieve the system pressure before doing any servicing on the control valve, piping or on the media tank.

- Turn off the water supply to valve and relieve the pressure inside as explained in section 9.0.1 & 9.0.2
- Unplug the electrical power, remove the wire cover screws and remove cover attached with 4 Philips screws.
- Please note that to remove or replace the PCB (circuit board), drive motor, or powerhead, the wires connecting to the micro switches are not required to be removed.

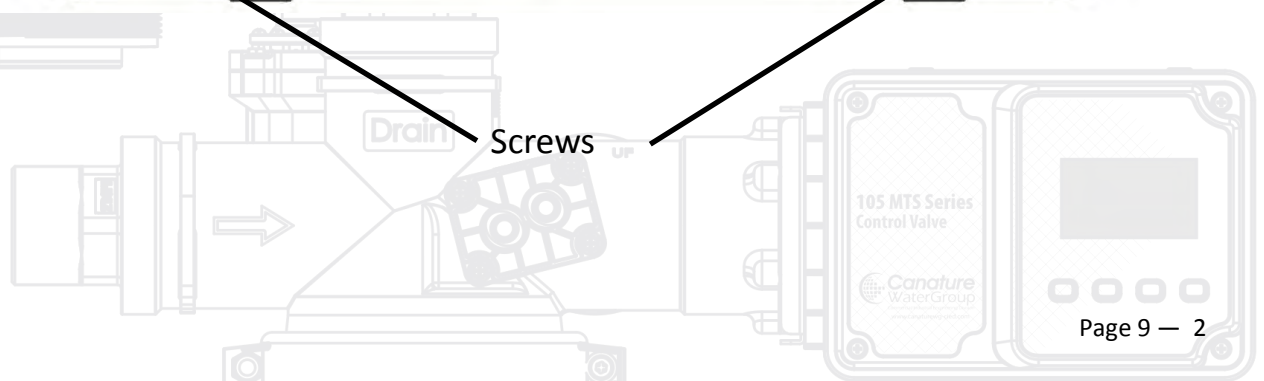
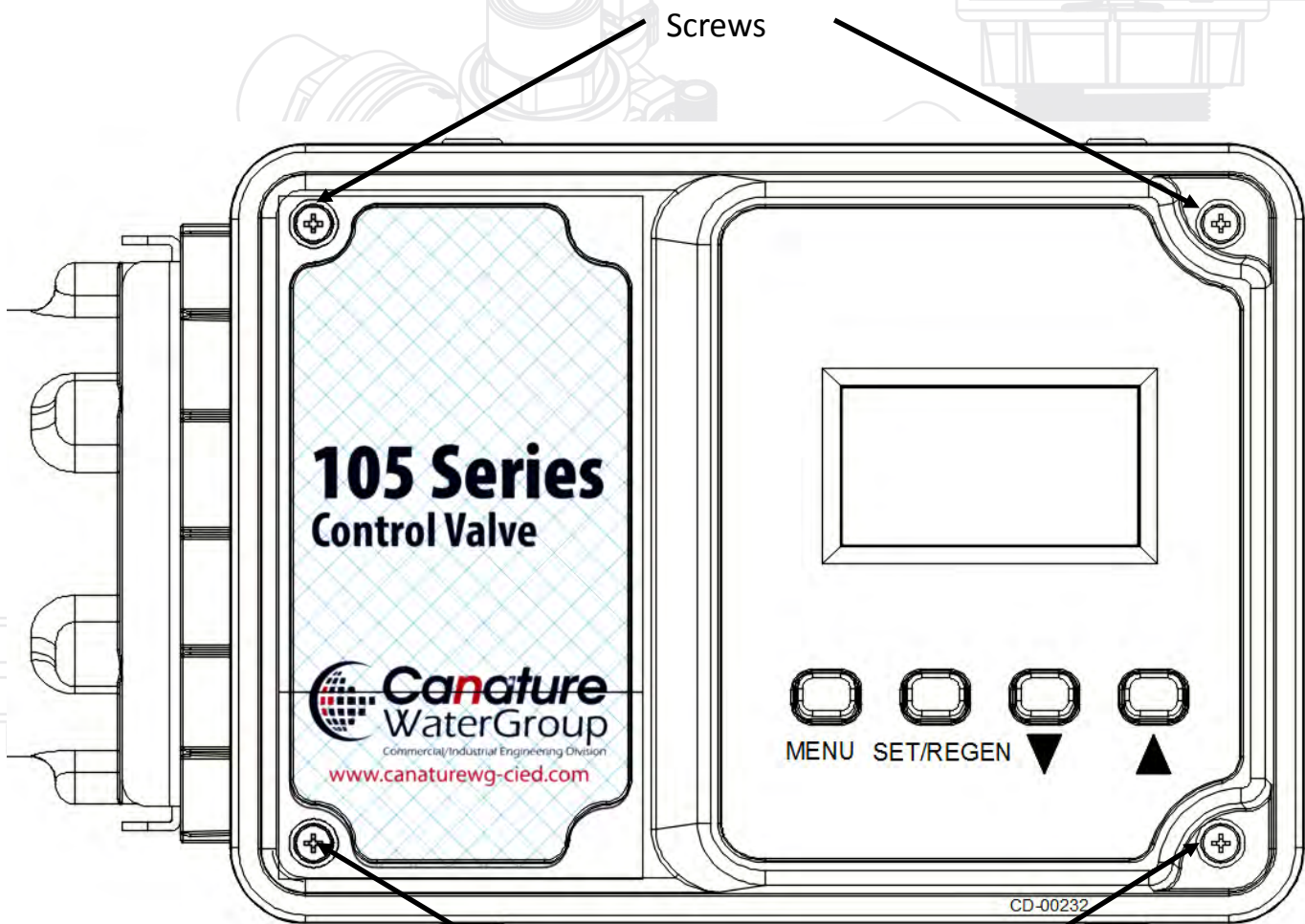

**PCB / Drive Motor / Power Head Removal**

**Section 9.1**

- Disconnect all internal wire plugs from the PCB circuit board back. Note the location of each (they are color coded). Be careful not to pull the wires out of their terminals. Use needle nose pliers or flat screw driver if necessary. Use the 2.4 mm flat screw driver to release any wires that are to the screw terminals. Remove the cover with the PCB.
- If replacing the PCB (circuit board), remove the four screws holding the board to the cover and replace the board. Reconnect the wires and replace the cover. Plug the system back in.
- Reprogram the system. Once the programming has been completed, step the valve through a complete regeneration cycle to ensure everything is operating as intended.

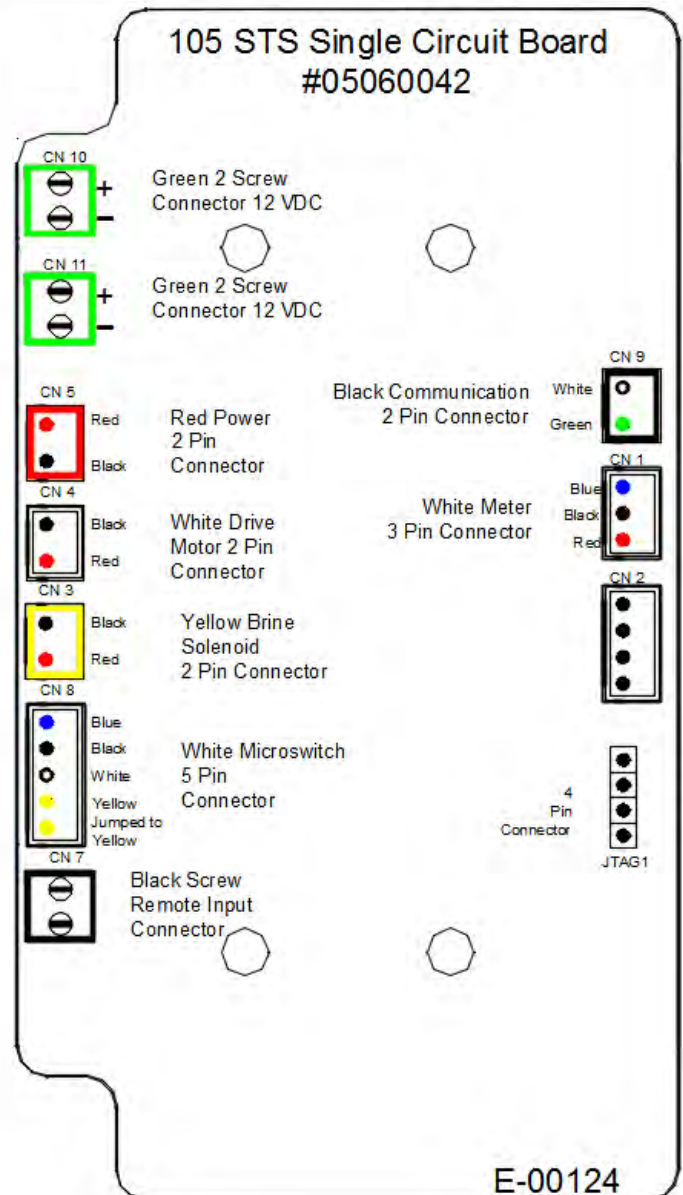
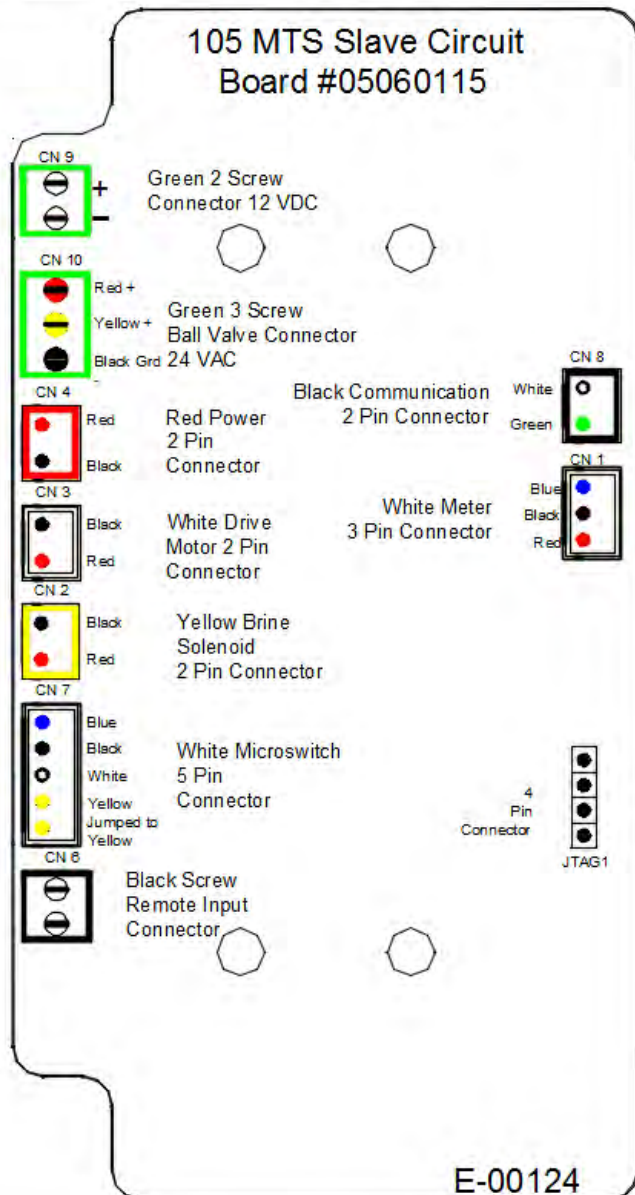
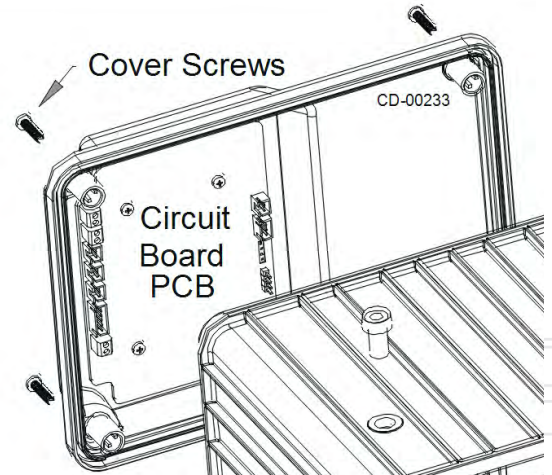



**PCB / Drive Motor / Power Head Removal****Section 9.1**

- Remove the four motor 6 mm Allen bracket bolts (05060065), using the 6 mm Allen wrench. There are two bolts on the top & two on the bottom of the plastic power head bracket (05060037). Carefully remove the motor assembly from the plastic power head bracket. **NOTE: Do not hold the motor assembly by the wire motor frame (05060074), as the wire frame is only pushed into the motor and can slip out.** Also note that the micro-switch wiring and motor wiring will come out with the motor assembly.

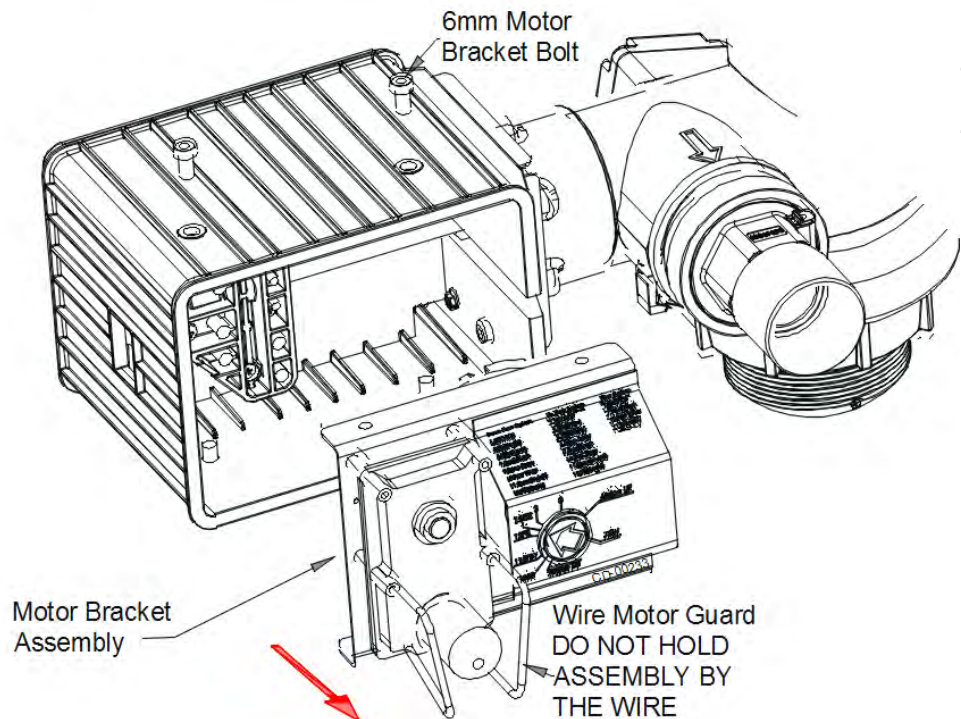

- Attached to the back of the motor bracket assembly is the drive cam, (05060109). Ensure the slot follower (05060023), is also removed. It rides on a shaft on the gear and it is easy to miss. When reinstalling the slot follower, be sure to silicone grease both the shaft it rides on as well as the slot it travels in.

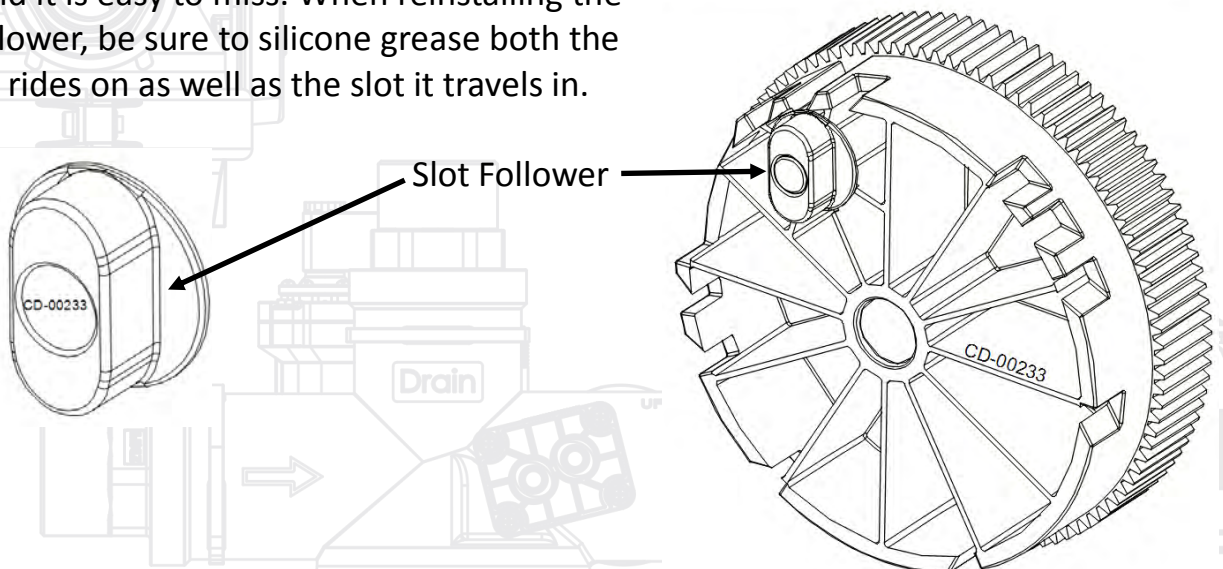



**PCB / Drive Motor / Power Head Removal****Section 9.1**

- To remove the large gear (05060109), loosen the bottom micro-switch screw and remove the top micro-switch screw. This will allow the micro-switches to be rotated slightly to allow the large gear to be separated from the motor assembly. The micro-switch wires do not have to be removed. When reassembling the large gear into the motor assembly be sure to depress the anti reverse pawl (05060035).

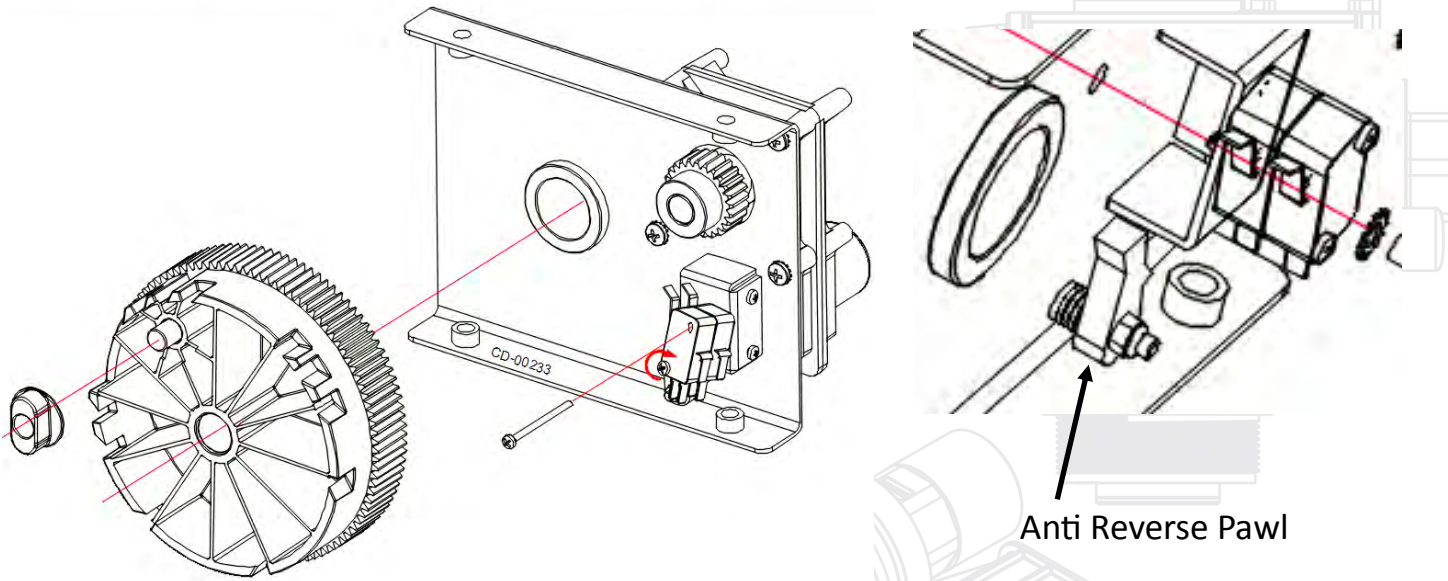

- Once the drive motor assembly has been separated from the power head bracket, the drive motor can then be removed from the assembly by unscrewing the four head screws. The motor drive gear can be removed from the motor "D" shaped shaft by loosening the 2.5 mm Allen head set screw. To reinstall motor assembly, see section 9.2.

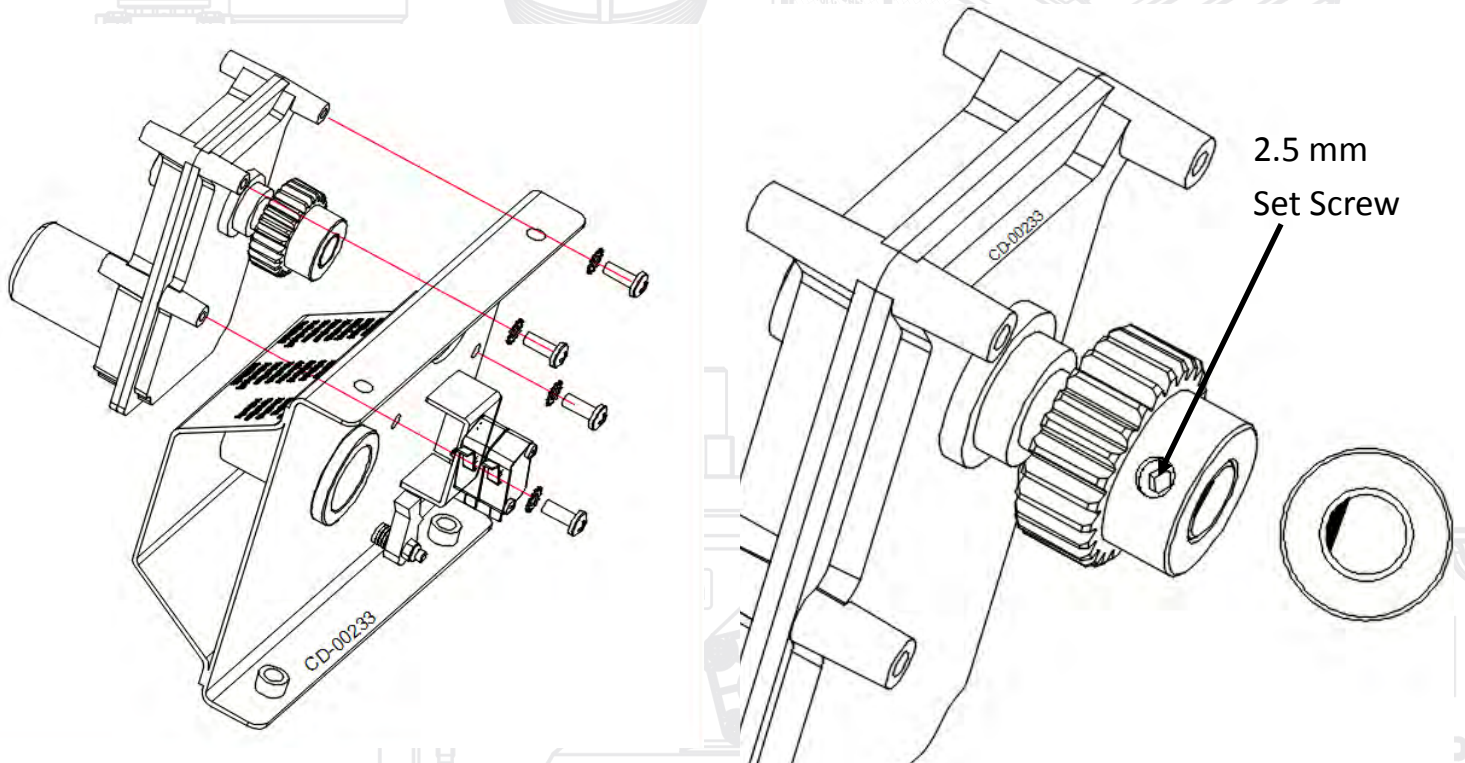

**PCB / Drive Motor / Power Head Removal**

**Section 9.1**

- There are six Allen head bolts holding the plastic power head bracket, (05060037). Remove the two smaller 4 mm Allen bolts (05056086B), using the 4 mm Allen wrench. Then remove the four 6 mm bolts (05060066). Please note that these 6 mm bolts are longer than the bolts previously removed. The plastic powerhead bracket can now be removed by moving the bracket to the left as illustrated below.

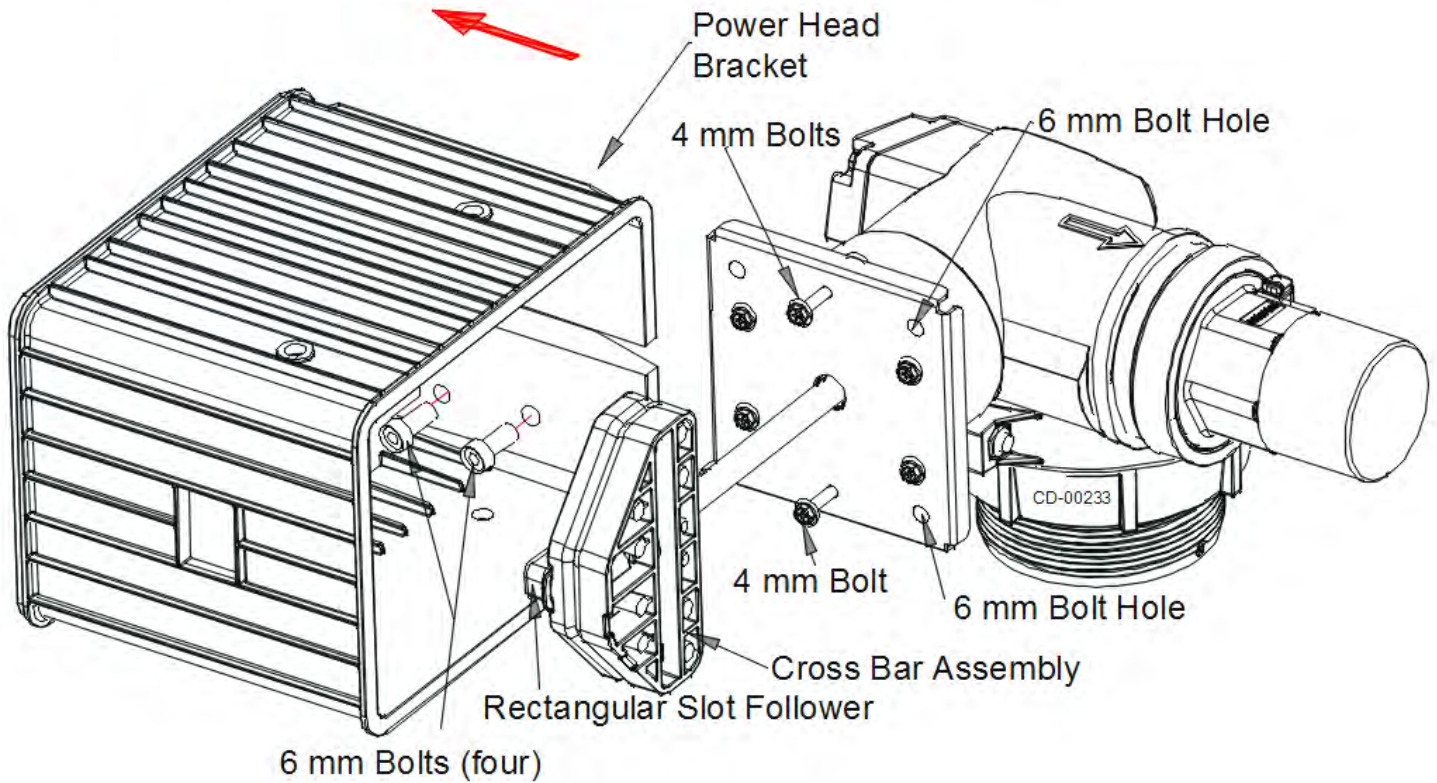

- Attached to the back of the cross bar assembly is the rectangular slot follower, (05060024). Ensure the rectangular slot follower is also removed. When reinstalling the slot follower, be sure to silicone grease the slot in the plastic powerhead bracket that it travels in.
- For assembly procedures, see section 9.2.

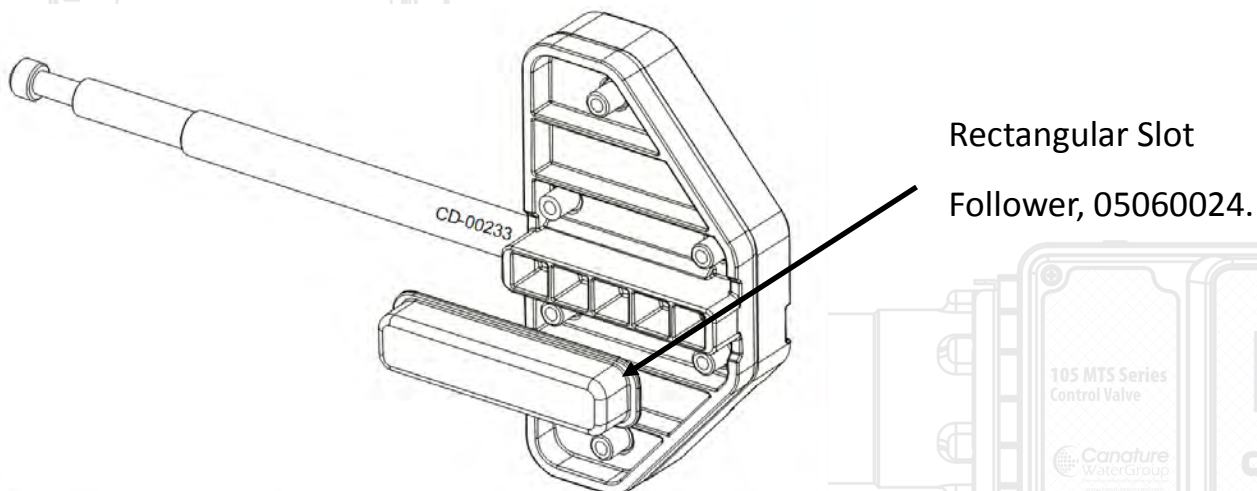

Rectangular Slot Follower, 05060024.



**Piston / Seal / Spacer (Lantern Ring) Replacement**

**Section 9.2**

- To replace the piston and / or the seals and spacers, first remove the powerhead. See section 9.1.
- Remove the four, 8 mm bolts holding the stainless steel end plate in place. (8 mm socket / nut driver or Philips screw driver).

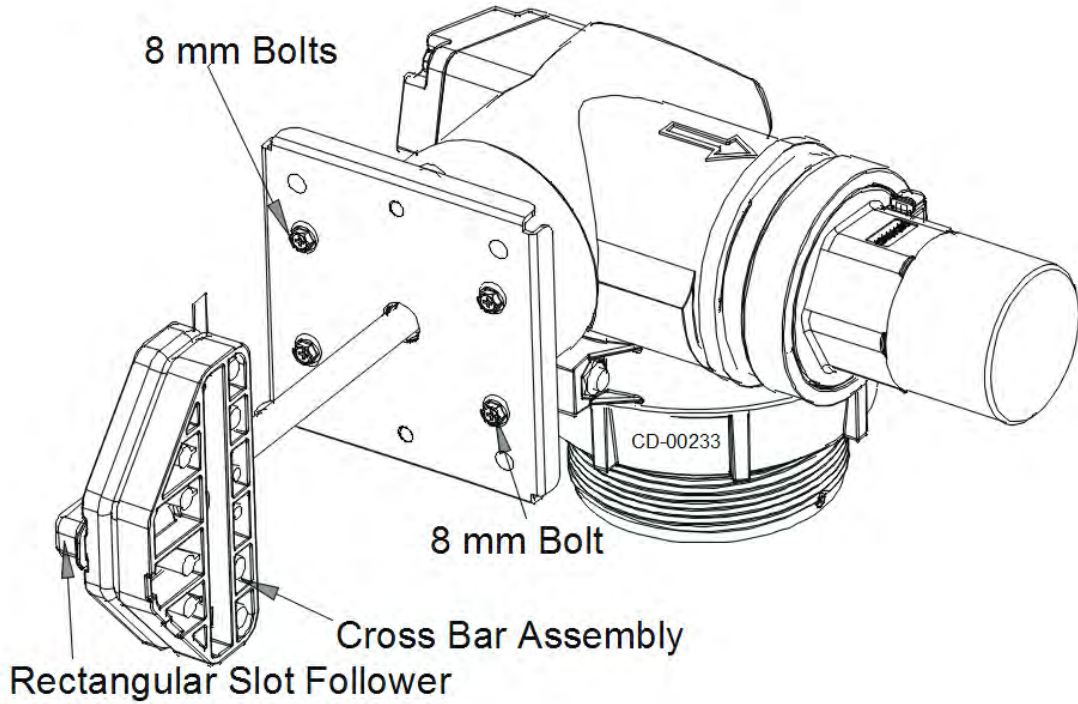

- **NOTE:** Some times pushing the piston assembly slightly in, and then pulling makes it a easier to slide the assembly out.

Grasp the crossbar assembly and slowly pull the end plug and piston assembly out of the valve body and set aside. Be careful to pull the piston assembly straight out. If that is not properly done, the piston rod and / or piston could be damaged.

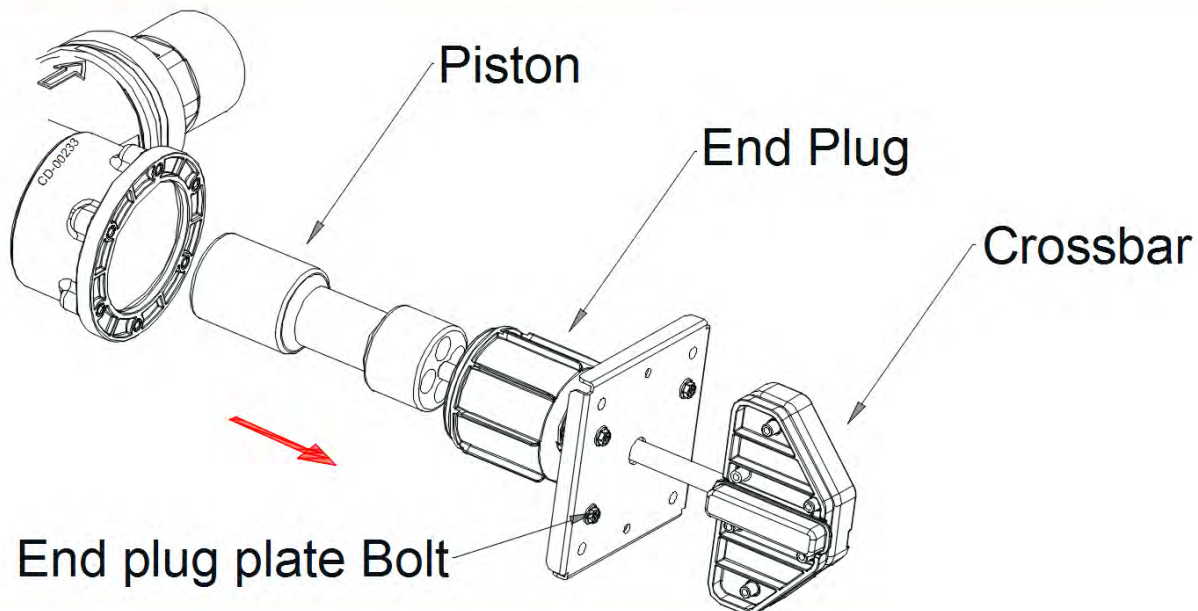



**Piston / Seal / Spacer (Lantern Ring) Replacement**

**Section 9.2**

- Pull out the tool together with the seals and spacer. Remove the spacer from the tool end by pushing button back with the pins retracted. A wire hook can be used to take the outer O-ring out from the valve body if it drop off during disassembly. On the diagram below, the proper sequence is shown for the seal /spacer / o-ring assembly with the colors listed. The diagram starting at the left side is the back of the valve, going to the right is the front of the valve. Note: If the no raw water piston PLUG option is used, the first seal is left out. If the no raw water bypass trailer piston is used, all seals are used. See section 10 for more details.

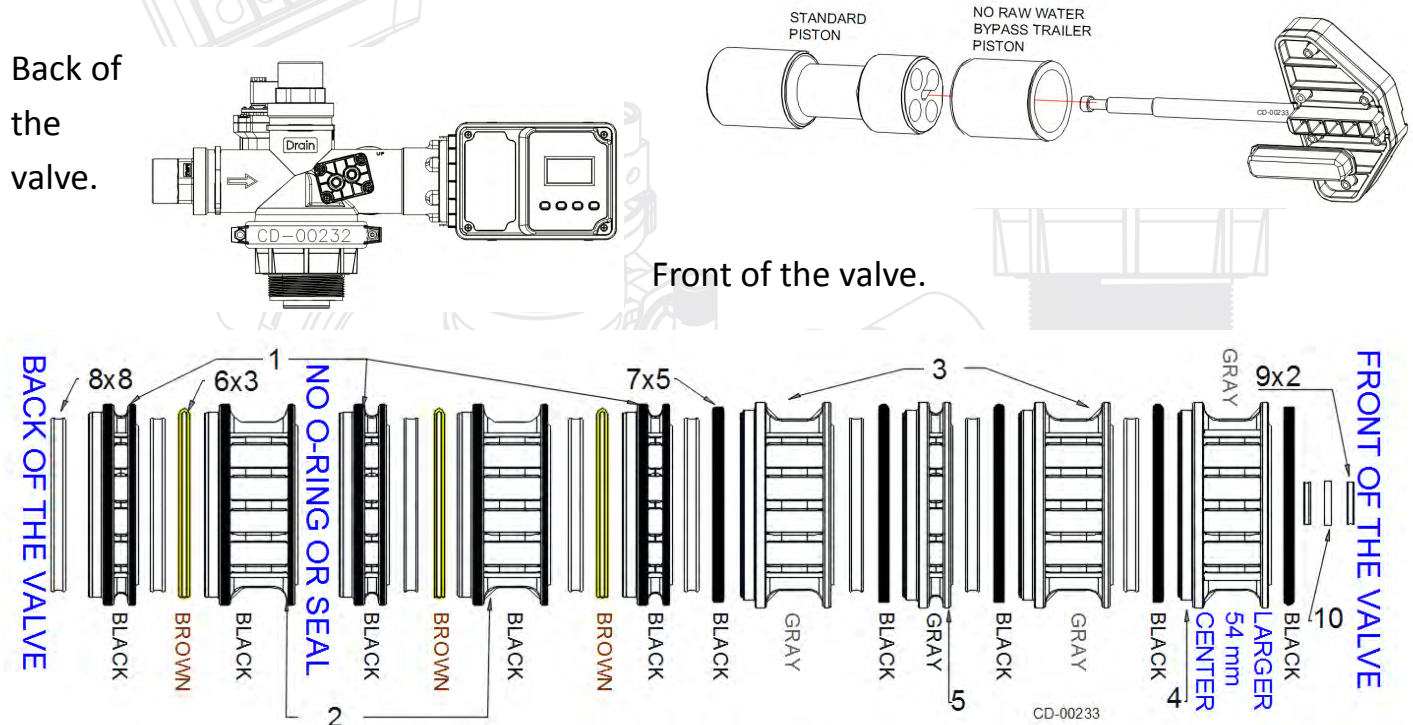

Item	Part Number	Description	Quantity
	<b>05060134M</b>	<b>Complete Kit (Individual parts shown below)</b>	
1	05060005	Lantern Ring I Black 50 mm	3
2	05060006	Lantern Ring II Black 50 mm	2
3	05060007	Lantern Ring III Gray 50 mm	2
4	05060098	Lantern Ring V Gray 54mm	1
5	05060008	Lantern Ring IV Gray 50 mm	1
6	05060056	O-Ring 59.92x3.53 Brown	3
7	05060057	O-Ring 63.09x3.53 Black	5
8	05060049	Quad Ring 50.17x5.33 Black	8
9	05060050	Quad Ring 12.37x2.62 Black	2
10	05060115	Quad Ring Gasket	1

**Piston / Seal / Spacer (Lantern Ring) Replacement****Section 9.2**

- A special tool (PN. 70020033) should be used to remove and install seals & spacers. The tool has four retractable pins. The pins are retracted or extended out by pulling or pushing the center button on the opposite end. This tool works on all the spacers except the first spacer which is usually pulled out by hand. The reason for this is the first spacer, (05060098), has a slightly larger center hole, (54 mm in diameter compared to 50 mm for all other spacers). It is **critical**, that this spacer is placed in the proper position when reassembling. It is important to note the order the seals , spacer and o-rings are removed as they must be installed in the correct order. They are not all the same.



- Insert the tool (PN. 70020033) into the valve body with the pins retracted, ( center button pulled back). Push the tool tight against the spacer and push the button in. When the button is pushed in, pins are pushed out to engage the holes in the spacer. The tool may have to be rotated slightly to allow the pins to extend into the slots of the spacers.

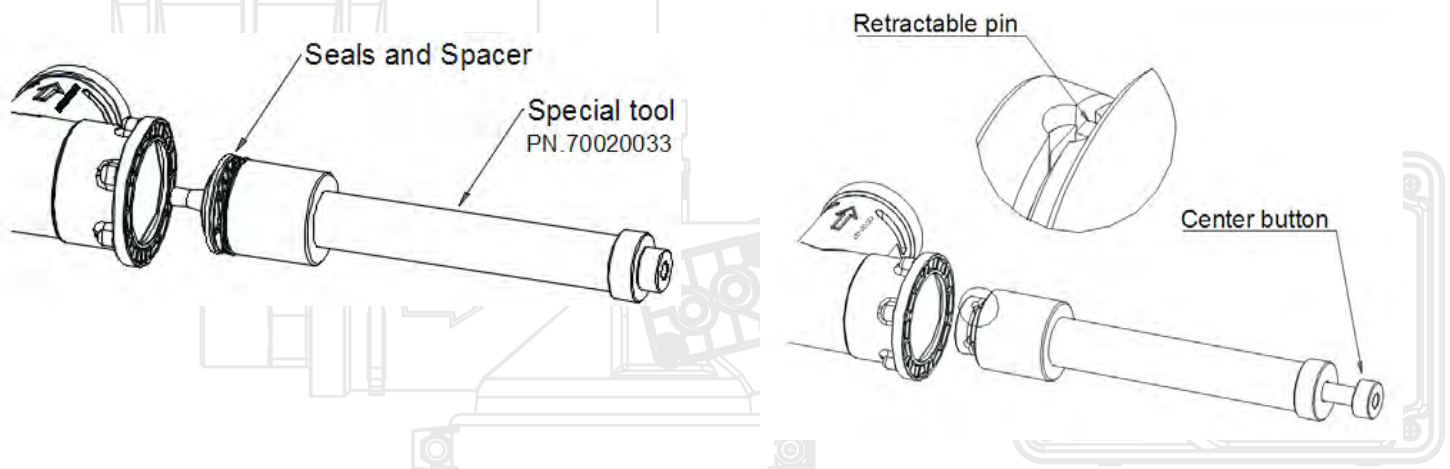



**Piston / Seal / Spacer (Lantern Ring) Replacement**

**Section 9.2**

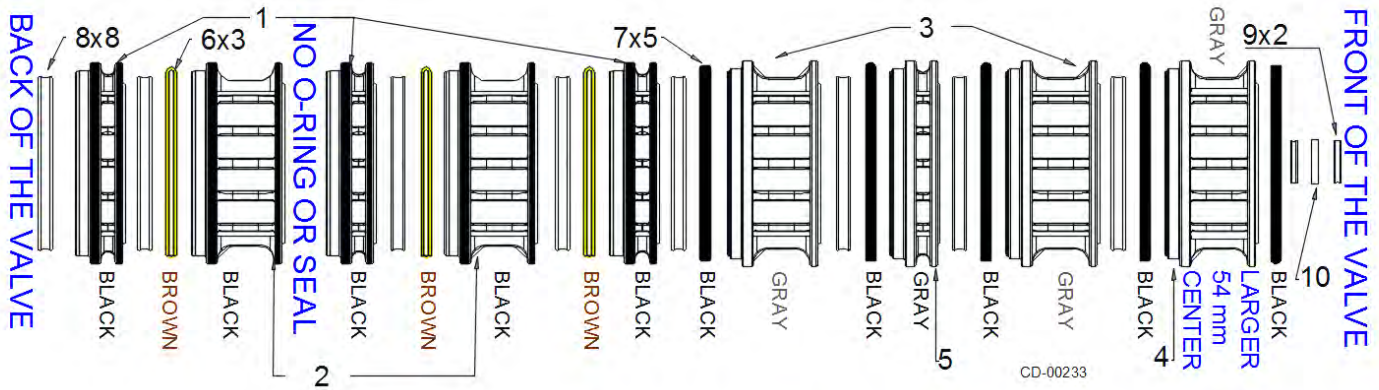

-To replace the seal & spacer assembly, install the new parts from left to right as shown in the diagram above.

-Use the silicone grease, (1014081-8 oz tube), liberally to coat the seals and O-rings. Assemble the seal inside the spacer and O-ring on to the outside of the spacer before installing it into the valve.

- Use the stuffer tool, (70020033), to lock on to the spacer assembly and carefully push in the spacer assembly into the valve.

- Repeat the above process until all the O-rings, seals (quad rings), and spacers (lantern rings) have been installed.

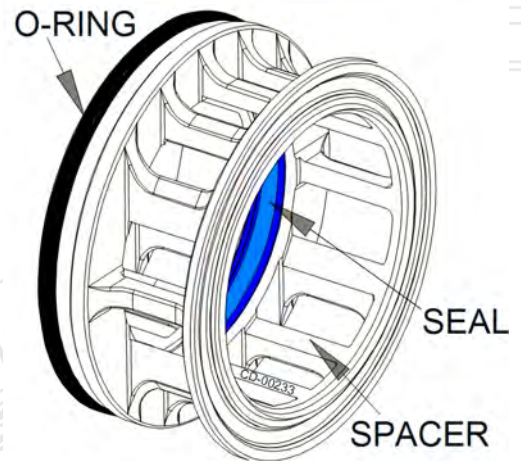

**IMPORTANT NOTES WHEN RE-ASSEMBLING THE SEALS AND SPACERS:**

- The last gray spacer, (05060098) to go into the valve has a larger hole that all the other spacers. It is **CRITICAL** that this spacer goes in last. If this is not followed, the trailer piston will not slide through, and will jam. The valve can be damaged and possibly burn out the motor.

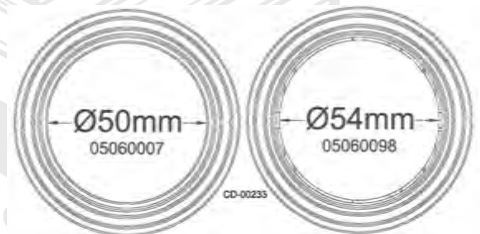

- Both the raw water bypass and no raw water bypass piston

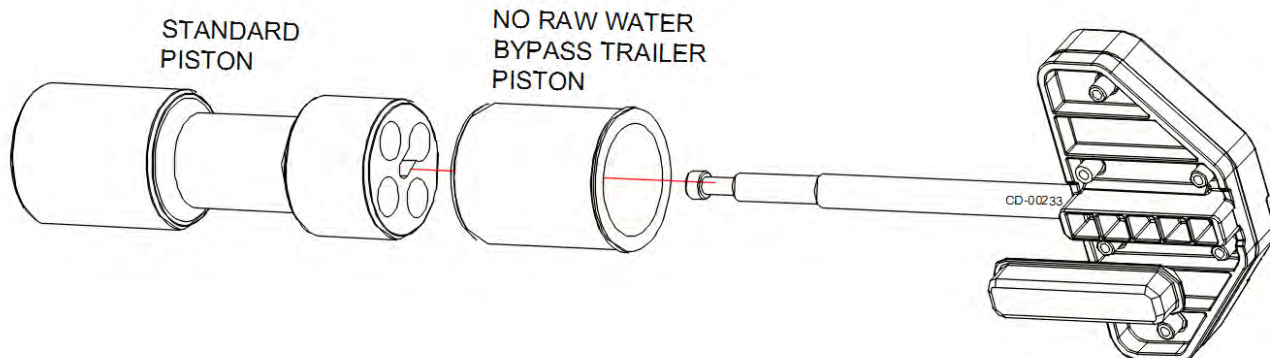

semblies use the identical seal / o-ring and spacer configuration.

**NOTE: There is no O-ring or seal between the second and third spacer from the back.**



**Piston / Seal / Spacer (Lantern Ring)**

**Section 9.2**

–Do a visual check through the center of the valve and ensure all the seals, spacer and O-rings are in place and fully inserted into the valve body.

- Reassemble the piston assembly keeping the piston rod slot pointing up to prevent the piston from sliding off the piston rod. Ensure the proper piston assembly is being used. The basic piston stays the same but a trailer piston or piston end plug can be used for no raw water bypass (see section 10.3.0).

- Apply silicone grease on to the piston, (and trailer piston if required) as well as the piston rod. Hold the cross bar assembly and the piston / end plug and carefully guide the assembly straight into the valve body.

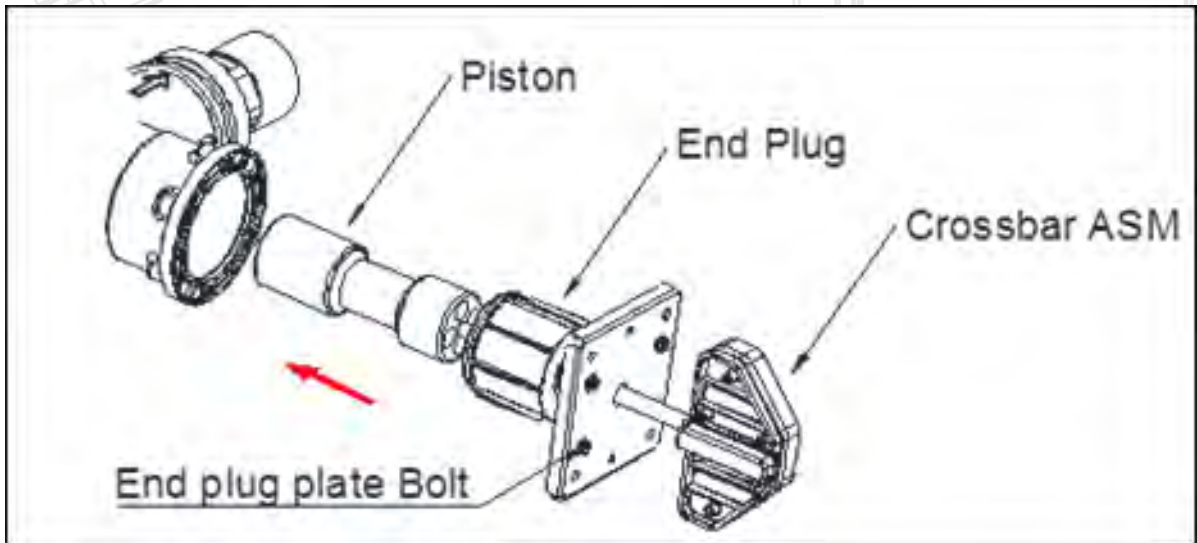

- The end plug will protrude approximately 1/8" to 1/4" out of the valve body until the end plate is attached. Use the four 8 mm bolts to attach the end plate .

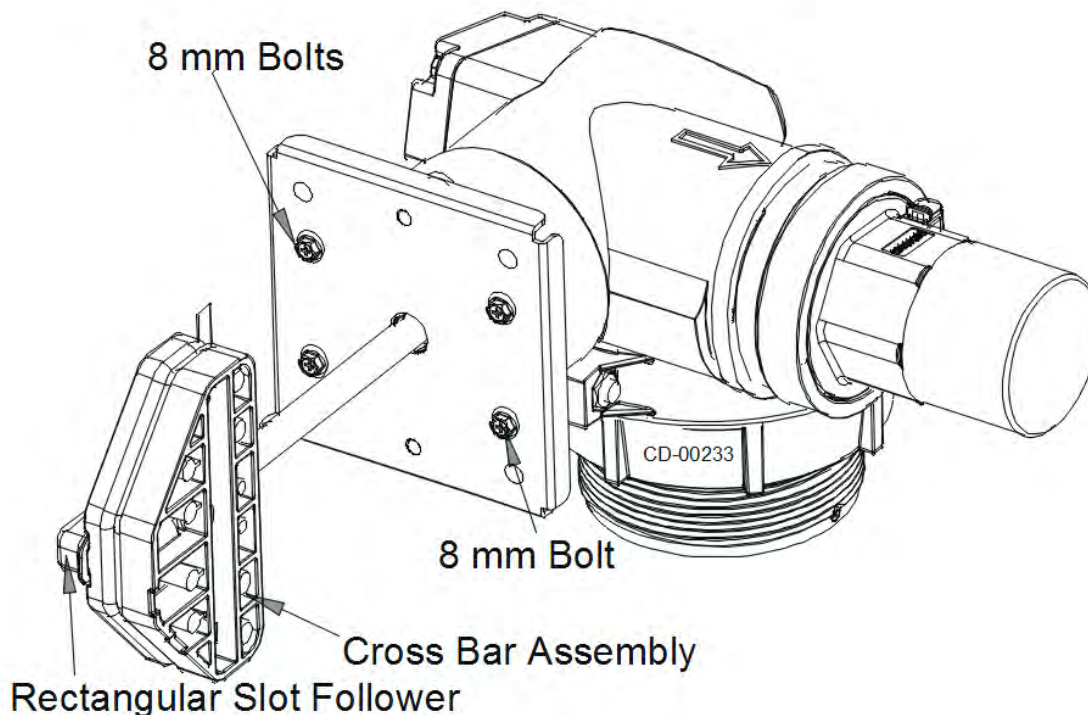

**Piston / Seal / Spacer (Lantern Ring) Replacement**

**Section 9.2**

-Confirm the piston assembly moves freely with one hand while holding the plate fixed on the valve body.

-The outer plastic bracket can now be reinstalled. **NOTE: INSTALL POWER HEAD BRACKET AS SHOW BELOW. The bolts do line up if reversed but the valve will not function as intended.** Lightly apply silicone grease into the cross bar track. Ensure the rectangular slot follower (05060024) has been installed onto the crossbar (see section 10.3.0). Install the power head bracket using the two 4 mm Allen bolts. **Note: APPLY ANTI SEIZE COMPOUND** on the four longer 6 mm Allen bolts.

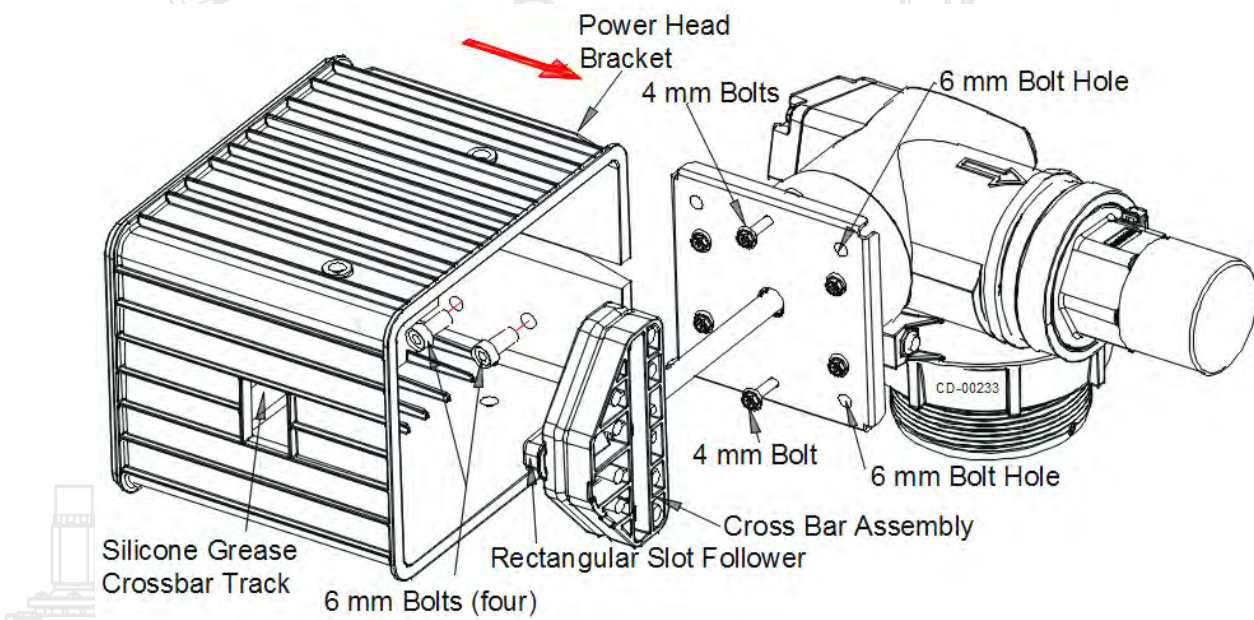

Align mark on power head bracket with cross bar assembly.

Lightly silicone grease cross bar track.

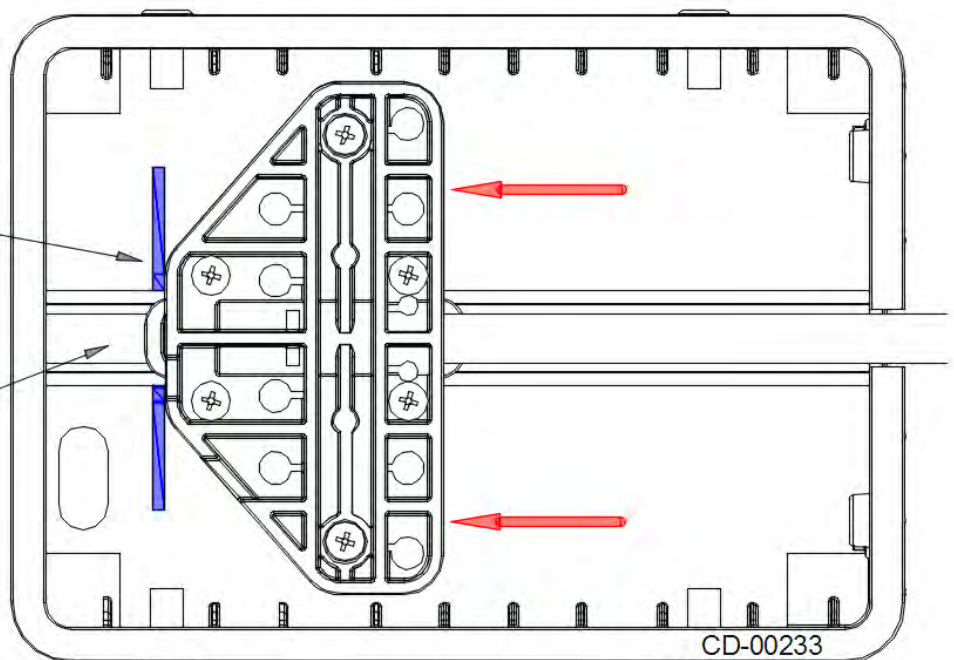



**Piston / Seal / Spacer (Lantern Ring) Replacement**

**Section 9.2**

- The motor drive assembly can now be installed. The motor cam gear must be installed at the **SERVICE** position as indicated by the arrow shown below.

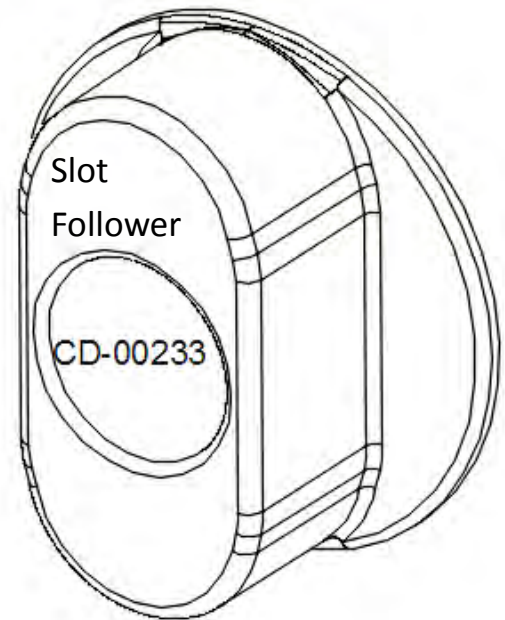
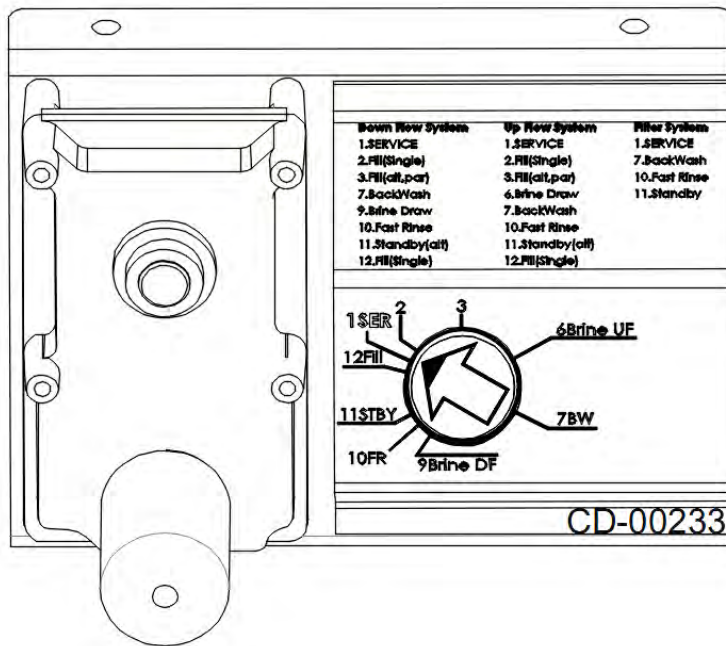

- The slot follower (05060023), must be at the **“3 O’clock”** position on the gear and vertical in orientation.

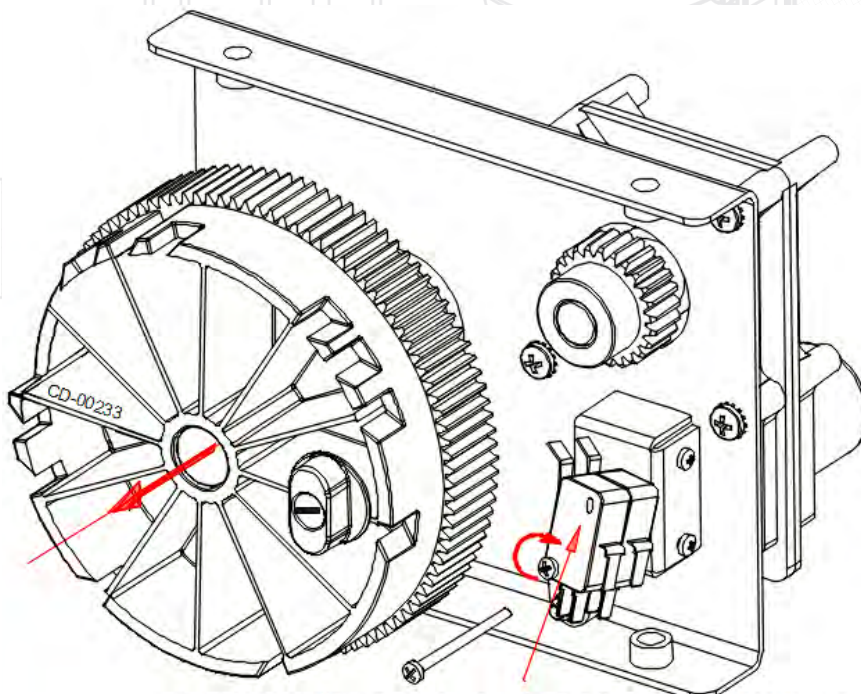

Remove top screw and rotate micro-switches so motor drive gear can be repositioned.

- If the motor cam gear is not in the correct orientation, remove the top micro-switch screw and rotate them out of the way. The motor gear can now be removed and positioned as required.

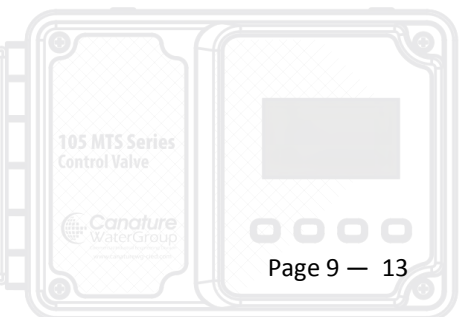



**Piston / Seal / Spacer (Lantern Ring) Replacement**

**Section 9.2**

- Apply silicone grease to the slot follower (05060023), the slot follower shaft, and the cross bar shaft guide. The silicone grease will also help hold the slot follower on it's shaft.

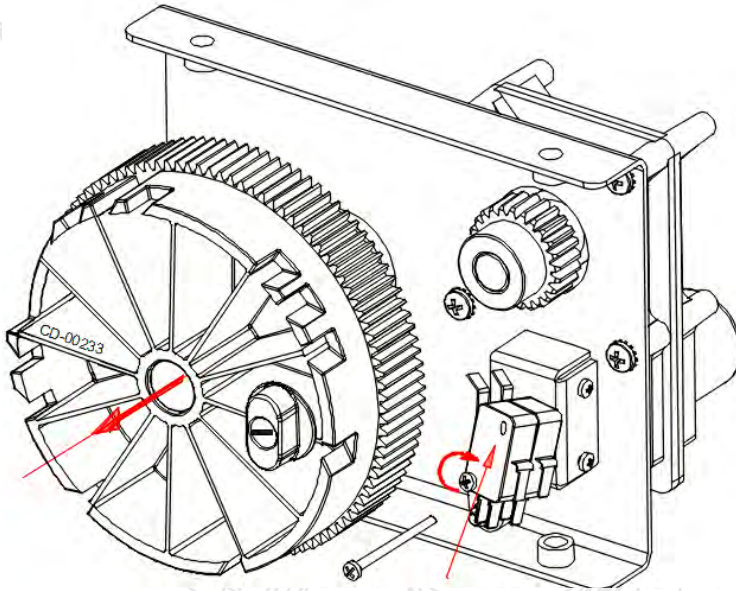

- Position the slot follower vertically on it's shaft as shown. Guide the motor drive and micro-switch wires through the power head housing as the motor assembly is slid in. The slot follower must slide into the cross bar vertical slot. Normally if the cross bar and the slot follower have been positioned as above, the motor assembly will slide right in. If you do have an issue, the slot follower can be viewed through the inspection window.

- NOTE: Use anti seize compound on the four 6 mm Allen bolts and use them to hold the motor assembly in place.

Align mark on power head bracket with cross bar assembly.

Lightly silicone grease cross bar vertical track.

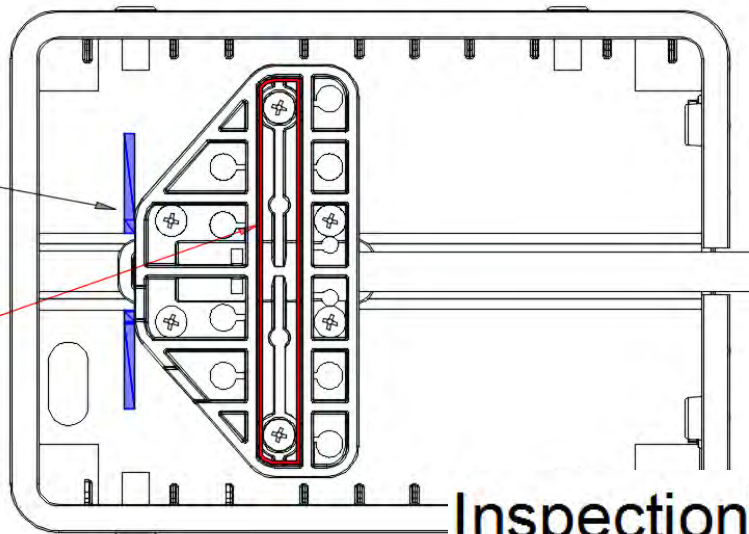

Inspection window

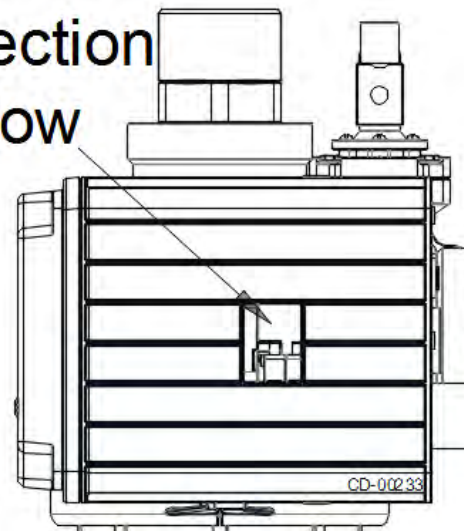

**PCB / Drive Motor / Power Head Removal****Section 9.2**

- Connect the wires to the circuit board (PCB). The wire clips are color coded to make it simpler to wire. Refer to the circuit board diagrams in section 9.1 if you are unsure of any connections.
- Install the circuit board cover on to the power head bracket. Plug the system back in.

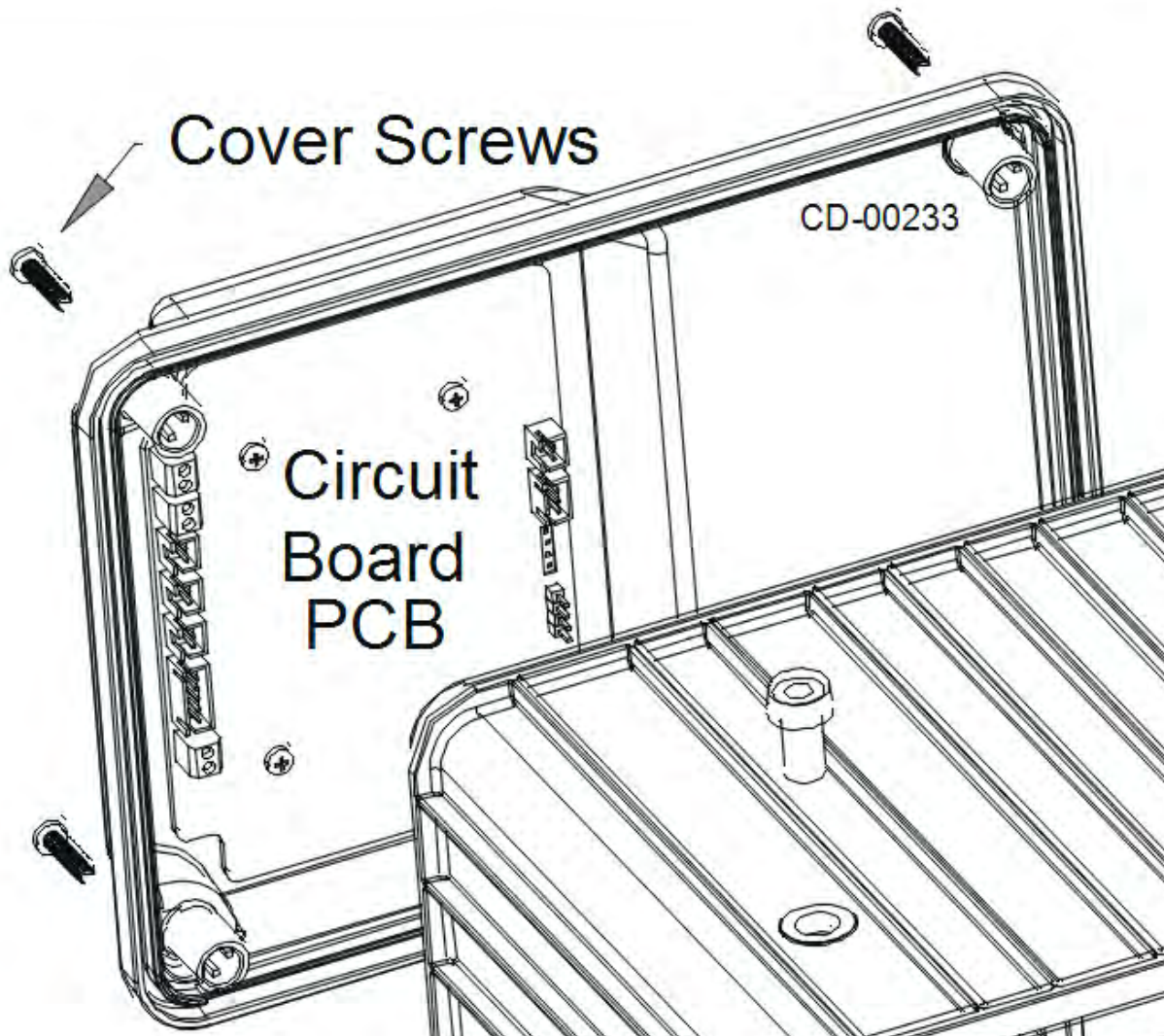

-If a new circuit board (PCB) has been installed, the system will have to be reprogrammed. Once the programming has been completed (if required), the system should be moved through a complete regeneration cycle to ensure everything is operating as intended.

**PLEASE NOTE: By stepping the control valve through a regeneration, the system assumed it has regenerated properly and will reset the capacity (or gallons) back to it's maximum. If the system was not fully regenerated when the system was cycled, a proper regeneration must be done.**



**Clean / Replace Injectors, DLFC, BLFC, And Meter**

**Section 9.3**

**Caution:** To prevent personal injury, or damage to the system, properly relieve the system pressure before doing any servicing on the control valve, piping or on the media tank.

-Turn off the water supply to valve and relieve the pressure inside as explained in section 9.0.1 & 9.0.2 before removing the meter and brine valve. It is also recommended to have the pressure off before removing the BLFC or DLFC .

-The DLFC (drain line flow control), has flow washers that control the maximum flowrate to the drain. If a button is missing or a larger flow washer than required is installed can result in too high of a backwash flowrate. This can result in some of the media backwashed out to drain.

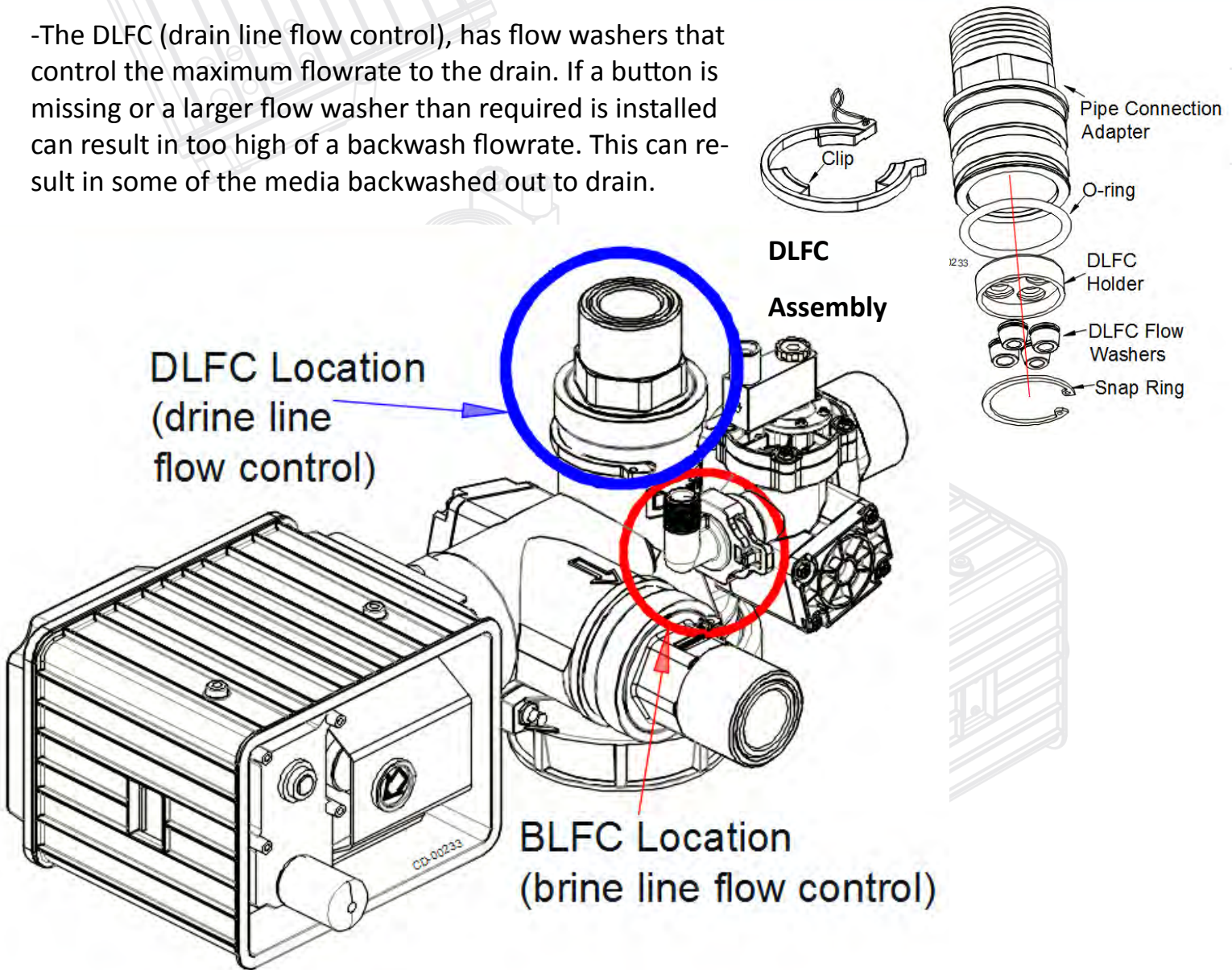

- The BLFC (brine line flow control), is located on the brine valve assembly and controls the refill flow rate to the brine tank.

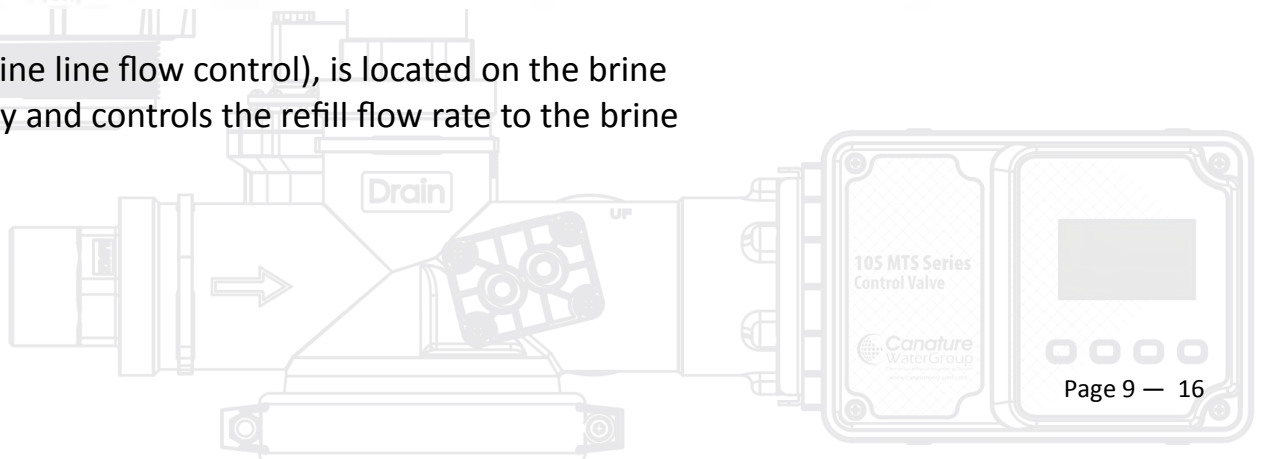



**Clean / Replace Injectors, DLFC, BLFC, And Meter**

**Section 9.3**

***Caution:*** To prevent personal injury, or damage to the system, properly relieve the system pressure before doing any servicing on the control valve, piping or on the media tank.

-Turn off the water supply to valve and relieve the pressure inside as explained in section 9.0.1 & 9.0.2 before removing the meter and / or the brine valve.

-The meter is an integral part of the outlet piping connection adapter. It can be easily taken apart to be cleaned. The meter and meter turbine will only fit one way so it can not be accidentally reversed.

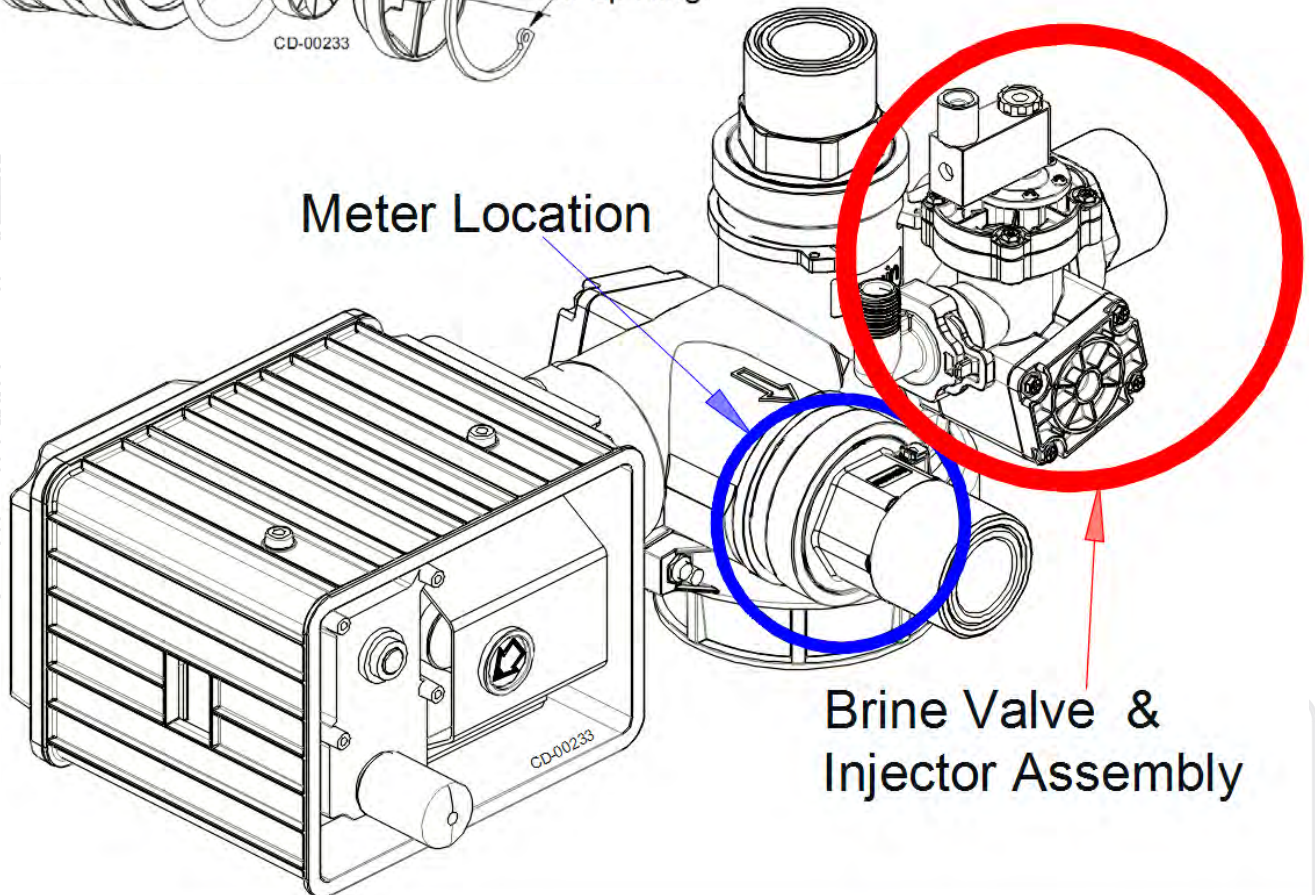
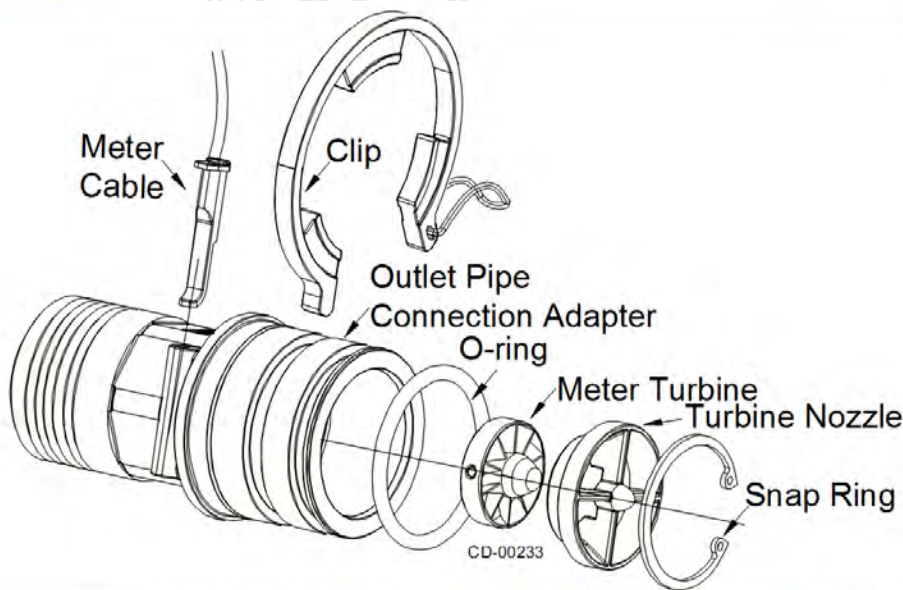

**Clean / Replace Injectors, DLFC, BLFC, And Meter****Section 9.3**

**Caution:** To prevent personal injury, or damage to the system, properly relieve the system pressure before doing any servicing on the control valve, piping or on the media tank.

- Sediment, salt and silt will restrict or clog the injector. A clean water supply and pure salt will prevent this from happening.
- Disconnect the brine line by removing the clip on the BLFC housing and pulling the housing out. Also disconnect the brine solenoid wiring by using a Philips screw driver and unthreaded the connector from the solenoid.
- Remove the four bolts holding the injector body on (use Phillips or 8 mm socket), and remove the injector assembly.

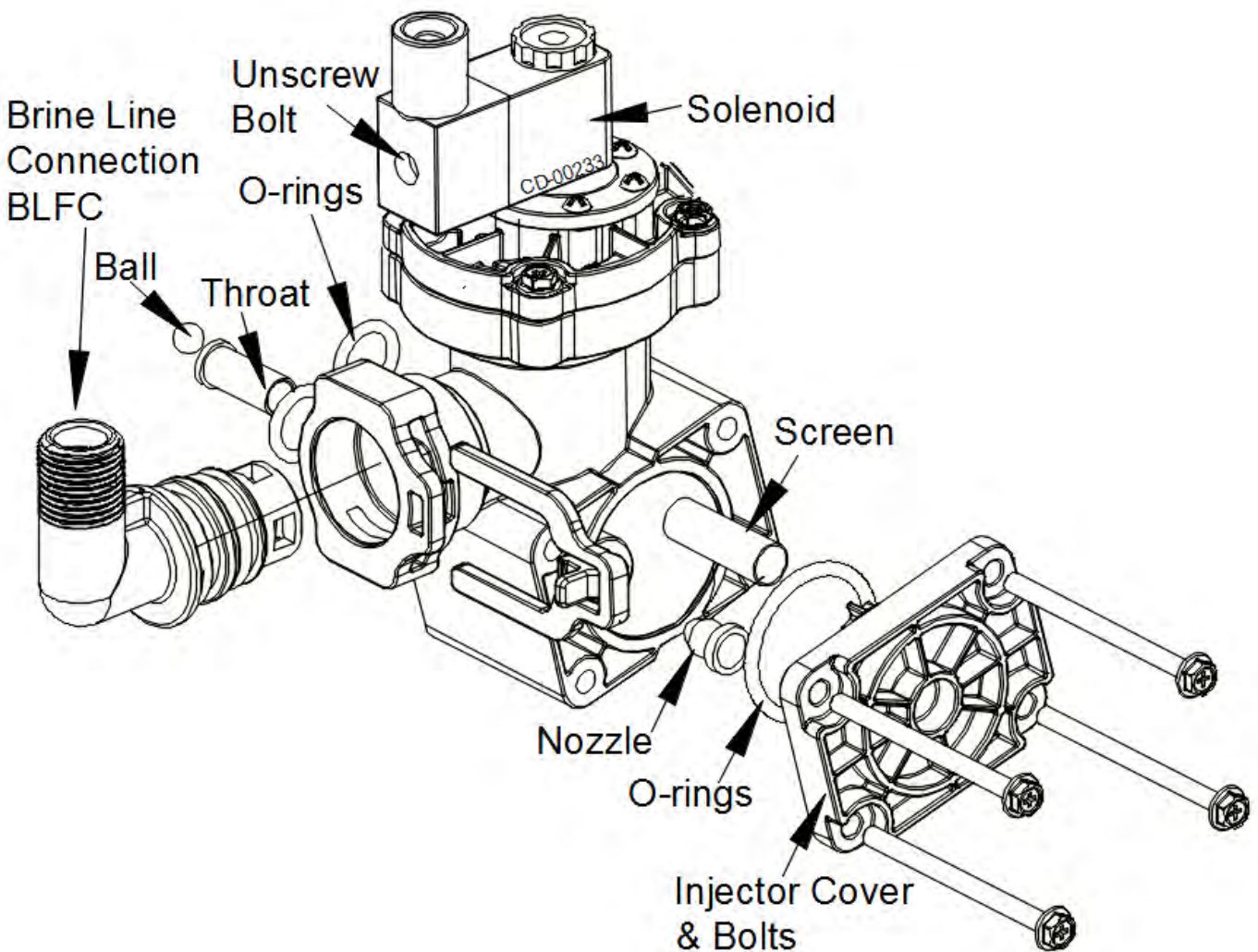

- The screen, throat and nozzle can be removed & cleaned. The throat & ball is removed from the back and the nozzle & screen is removed from the front. After cleaning, reassemble the injector assembly. Ensure all O-rings are lightly greased and installed correctly. See section 9.4 for recommended procedures for installing O-rings.



**Installing O-rings**

**Section 9.4**

If any O-ring is not installed properly, there is a good chance the connection will leak. The way to install an O-ring depends upon the actual connection itself.

There are two main types of O-ring connections:

- #1- Connections that do NOT have a O-ring groove on the part connections.
- #2- Connections that have an actual groove for the O-ring on part connections.

When installing the O-rings on connections that do NOT have an O-ring groove (#1), the procedure is as follows:

- Inspect the O-ring for any nicks or cuts. If any are found, replace the O-ring.
- Use food grade silicone grease to lightly coat the O-ring and all surfaces the O-ring will contact (both the male & female surfaces).
- Install the O-ring on the MALE connection & ensure that the O-ring is not twisted.
- Install all other required parts and slide the connection together.

Pictured below is a diagram reflecting example #1.

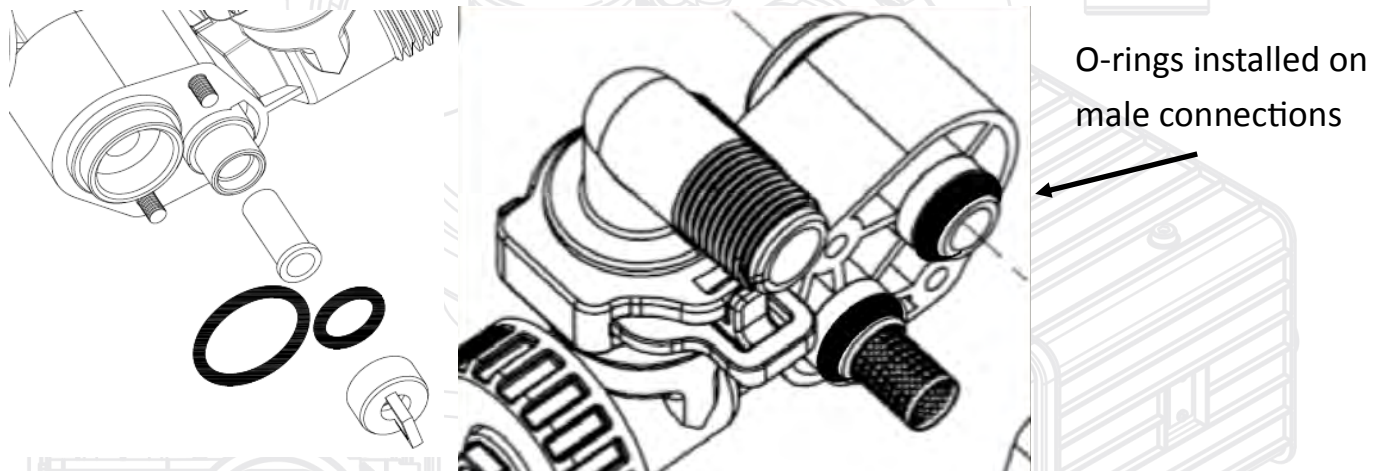

Pictured below and to the right is a diagram reflecting example #2.

In this situation, there is a groove designed into the connection for the O-ring to be seated into place.

Installation procedure is as follows:

- Inspect the O-ring for any nicks or cuts. If any are found, replace the O-ring.
- Use food grade silicone grease to lightly coat the O-ring and all surfaces O-ring will contact (both the male & female surfaces).
- Install the O-ring into the appropriate groove on the connection.
- Ensuring the O-ring is not twisted, slide the connection together.

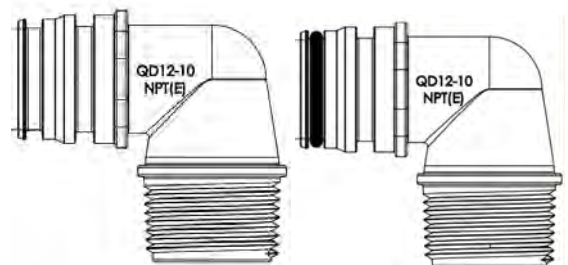



## Repair Parts –Tanks

## Section 10.1

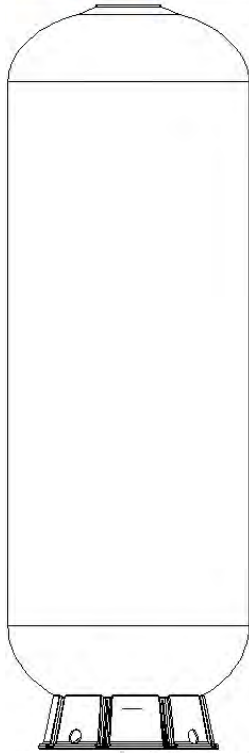

Section 10.1	MINERAL TANKS	Part Number
14" Diameter x 65" Natural	4" Threaded Top Hole Std Base	25030001
16" Diameter x 65" Natural	4" Threaded Top Hole Std Base	25030002
18" Diameter x 65" Natural	4" Threaded Top Hole Std Base	25030014
21" Diameter x 62" Natural	4" Threaded Top Hole Std Base	25030003
24" Diameter x 72" Natural	4" Threaded Top Hole Std Base	25030004
30" Diameter x 72" Natural	4" Top & Bottom Hole Tripod Base *	25030030
30" Diameter x 72" Natural	6" Top & Bottom Flanged Tripod Base	25030033
36" Diameter x 72" Natural	4" Top & Bottom Hole Tripod Base *	25030040
36" Diameter x 72" Natural	6" top & bottom flanged tripod base	25030043
<b>Tank Closures, Adapters and Accessories</b>		
Adaptor, Tank, 4" Thread X 2-1/2" Thread CANATURE		50040039
O-ring #342 Replacement For Above		15210
4" Thread Tank Closure		50040075
6" FLANGE CLOSURE JD 506 c/w Bolt Kit		50040148
6" FLANGE CLOSURE WITH 4" THREAD JD507 c/w Bolt Kit		50040149
Bolt Kit For 6" Flanges 12-5/16" x 3" Long SS Nuts & Washers		97000738
Flexible Piping Connectors. (Required with rigid piping)		
Connector, Flex, 1.25"x18"L *(Stock)		80127822
Connector, Flex, 1.25"x24"L		80127823
Connector, Flex, 1.5"x18"L *(Stock)		80127824
Connector, Flex, 1.5"x24"L		80127825
Connector, Flex, 2"x18"L *(Stock)		80127826
Connector, Flex, 2"x24"L		80127827
Vacuum Breaker, 1.5" MNPT		310527
VALVE VACUUM BREAKER 1/2" NPT 12N36		60020204
Vent, Air release Braukman 1/8" MNPT		50701
* Non Standard Tank		all units mvs.xlsx

## Repair Parts –Distributions

## Section 10.2

Section 10.2	DISTRIBUTION	Part Number
<b>For Top Mounted Control Valves ( No Riser Pipe Is Included)</b>		
High Flow Hub & Laterals 13"-16" JD 324 (1.5" Riser Not Included)		50040160
HIGH FLOW HUB & LATERALS 18"-21" JD 306 (1.5" Riser Not Included)		50040161
HIGH FLOW HUB & LATERALS 24" JD 307 (1.5" Riser Not Included)		50040117
HIGH FLOW HUB & LATERALS 30" JD 308 (1.5" Riser Not included)		50040118
HIGH FLOW HUB & LATERALS 36" (1.5" Riser Not Included)		50040119
<b>Adapters &amp; Pipe For Top Mounted Valve Distributions</b>		
1.5" Sch 40 Pipe (NOTE Sold By The Foot)		1120066

105 Valve Repair Parts

Section 10.3.0

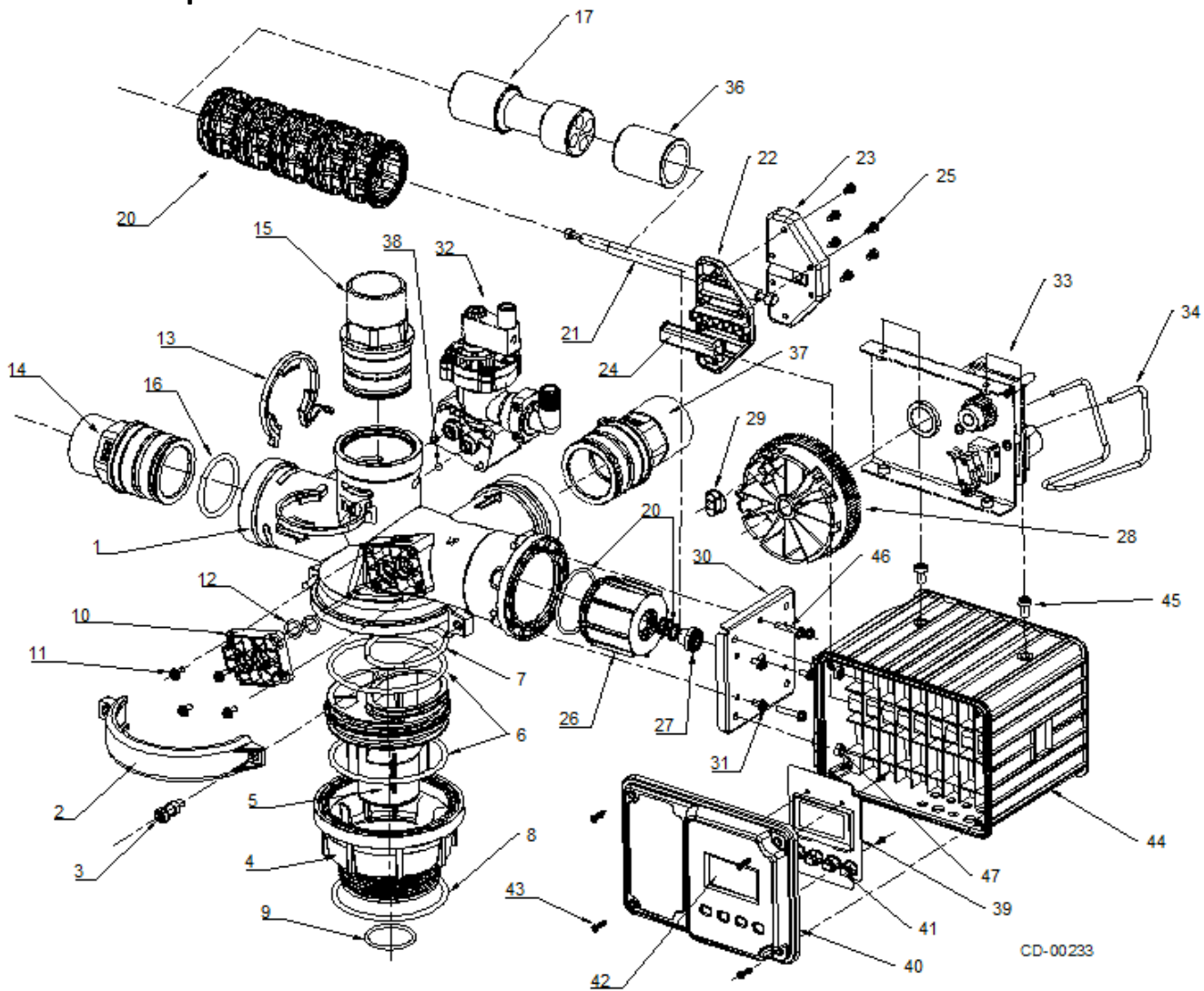

CD-00233

Drawing 10.3.0 item number	Description	Quantity
14 - 15	105 End adapters /DLFC kits See section 10.3.4	1
20	105 Seal & spacer (lantern) kits See section 10.3.2	1
32	105 Asperator kits See section 10.3.1	1
33	105 motor assemblies See section 10.3.3	1
37	105 Meter adapters See section 10.3.5	1
39	105 Circuit boards and cables See section 10.3.6	1
<b>05060002-K Kit,105,tank adpater 02170302</b>		
9	O ring 46.99x5.33 1.9"OD	1
4	Tank adaptor 105	1
5	Support, rise pipe 1.9"OD	1
7	O ring 75.57x5.33	1
6	O ring 110.49x5.33	2
3	Bolt M8x25	2
2	Clamp,victaulic ,105	2
3	#8 spring washer	2
3	Nut M8	2
8	O-ring 108X5.3 4" valve base	1
Not shown	Silicone grease 1 gram package	1



## 105 Valve Repair Parts

## Section 10.3.0

10.3.0 item number	Description	Quantity
<b>05060002-O Kit,105,o-rings,tank adapter 02170305</b>		
9	O ring 46.99x5.33 1.9"OD	1
7	O ring 75.57x5.33	1
6	O ring 110.49x5.33	2
8	O-RING 108X5.3 05040094	1
Not shown	Silicone grease 1 gram package	1
<b>05060015-K Kit,105,plug,aspirator filter 02170296</b>		
10	Aspirator plug	1
11	Screw,cover, bolt M5-12	4
12	O-ring,14X3 05040084	2
Not shown	Silicone grease 1 gram package	1
<b>05060037-B Kit,105,bolts,powerhead 02170300</b>		
46	Bolt M5x30	2
45	Bolt M8x14	4
47	Bolt M8x30	4
Not shown	Washer 5*15 (for 47)	2
43	Screw ST3.5x22	4
39	SCREW ST2.9X9.5	4
<b>05060081-K Kit,105,piston rod assembly 02170304</b>		
22	Crossbar, top	1
23	Crossbar, bottom	1
29	Slot follower	1
24	Slot follower, rectangle	1
25	Screw ST4.8x13	6
21	Piston rod	1
Not shown	Silicone grease 1 gram package	1
<b>05060021-K Kit,105,end plug assembly 02170299</b>		
46	Bolt M5x30	2
26	End plug	1
27	Flanged Bushing	1
part of 20	Quad ring 12.37x2.62	2
part of 20	O ring 63.09x3.53	1
part of 20	Washer 5*15	2
part of 20	Retainer,insert,105 End	1
31	Screw,cover. Bolt M5-12	4
Not shown	Silicone grease 1 gram package	1
<b>05060009-R Kits 105 Piston Assembly RWB</b>		
17	Piston 105	1
05060081-K	Kit,105,piston rod assembly	1
05060021-K	Kit,105,end plug assembly	1
<b>05060009-N Kits 105 Piston Assembly NRWB</b>		
17	Piston 105	1
36	Trailer piston	1
05060081-K	Kit,105,piston rod assembly	1
05060021-K	Kit,105,end plug assembly	1

## 105 Valve Repair Parts

## Section 10.3.0

<i>Item</i>	<i>Description</i>	<i>Quantity</i>	
1	Body, valve 105	1	
2	Clamp, Victaulic ,105	2	
	Bolt M8x25	2	
3	Φ8 spring washer	2	
	Nut M8	2	
4	Tank adaptor 105	1	
5	Support, Rise pipe 105	1	
	Support, RisePipe 1.9"OD		
	O ring retainer	1	
6	O ring 110.49x5.33	2	
7	O ring 75.57x5.33	1	
8	O ring 108x5.3	1	60010228
9	O ring 46.99x5.33 1.9"OD	1	05042005
10	Aspirator plug	1	
11	Bolt M5x12	4	
12	O ring Φ14x3	2	
13	C Clip (also requires 05060125 below)	3	05060026
	C Clip tightener	3	05060125
14	Adapter, 2.0" NPT (also requires 05060058)		05060031
	Adapter, 1.5" NPT (also requires 05060058)		05060034
15	Adapter Drain ASM W/ DLFC	1	See section 10.3.4
16	O ring 56.52x5.33	3	05060058
17	Piston, 105 Valve	1	05060009
20	Kit, Seal, Spacer 105 valve	1	05060134M
21	Piston Rod	1	
22	Crossbar, Top	1	
23	Crossbar, Bottom	1	
24	Slot follower, Rectangle	1	05060024
25	Screw ST4.8x13	6	
26	End plug	1	
27	Flanged Bushing	1	
28	Cam & Gear with Pin	1	
29	Slot follower	1	05060023
30	End plug plate	1	
31	Bolt M5x12	4	
32	Valve, Brine Assy 105 Valve	1	See section 10.3.1
33	Inner Bracket Assembly	1	
34	Motor Frame	1	
35	O ring 41x1.78	1	
36	Trailer piston	1	05060010
37	Meter/Conn, 105V-2" NPT Outlet W/ Meter Assembly		See section 10.3.5
37	Meter/Conn, 105V-1.5" NPT Outlet W/ Meter Assembly		See section 10.3.5
38	Throat Check ball	1	05060140

**105 Valve Repair Parts**

**Section 10.3.0**

<i>Item</i>	<i>Description</i>	<i>Quantity</i>	
39	Circuit board, PCB	1	See section 10.3.6
	Screw ST2.9x9.5	4	
40	Wire cover	1	
41	Rubber button	4	
42	Clear panel	1	
43	Screw ST3.5x22	4	
44	Plastic Outer Bracket	1	05060037
45	Bolt M8x14	4	
46	Bolt M5x30	2	
	Washer 5*15	2	
47	Bolt M8x30	4	
48	Wire harness --Not shown	1	See section 10.3.6
Not shown	Silicone grease 8 oz tube	1	1014081
			105 Modified-Sub assemblies.xlsx

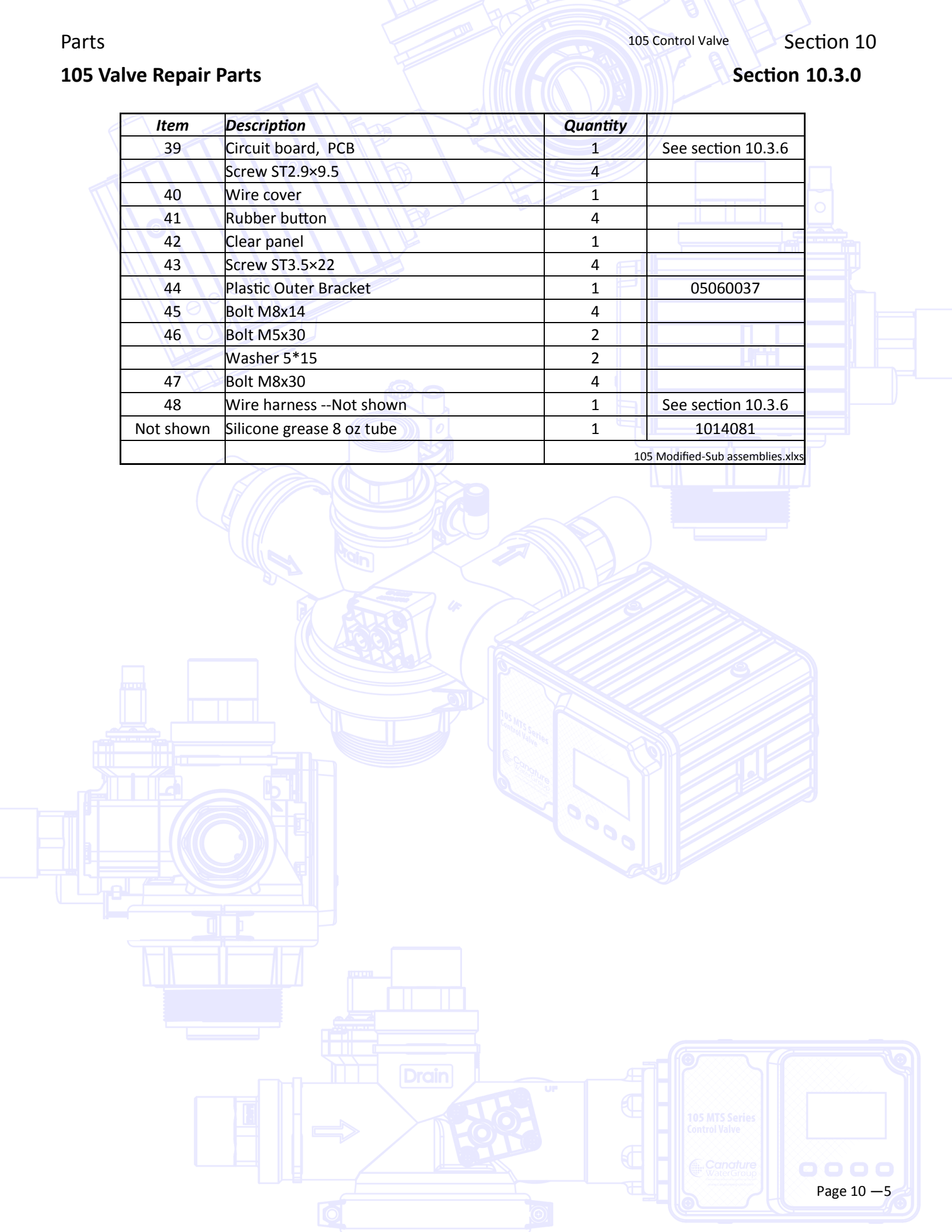



105 Brine Valve & Injector Assembly

Section 10.3.1

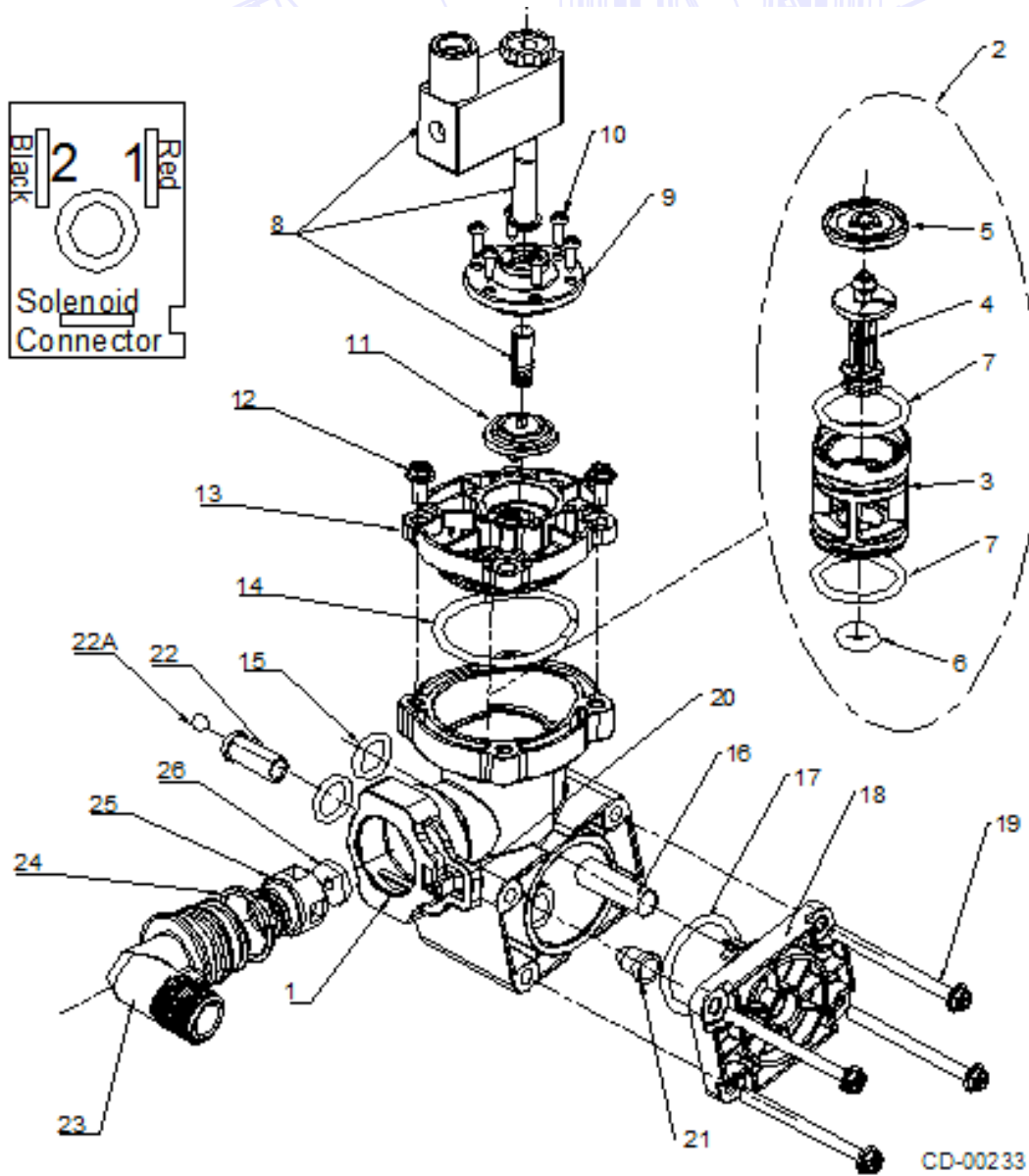

All items on above drawing		<b>05060105-T Kit, complete 105 aspirator c/w solenoid, wiring harness and injectors</b>	
10.3.1	Item	<b>05060105-P Kit, aspirator bolt</b>	Quantity
	#10	Screw ST3.5x13	6
	#12	Bolt M5x16	4
	#19	Bolt M5x68	4
		<b>05060105-O Kit, aspirator o-rings</b>	
	17	O ring 34.52x3.53	1
	14	O ring 40.87x3.53	1
	16	Screen, nozzle	1
	22A	Throat check ball,71mm	1
	24	O-ring,drain,	1
	15	O-ring,14X3 05040084	2
	Not shown	Silicone grease 1 gram package	1

## 105 Aspirator -Brine Valve &amp; Injector Assembly

## Section 10.3.1

Item	Description	Quantity	Part #
1	Aspirator Housing	1	
2	Brine Plunger Assembly	1	
3	Retainer Housing	1	
4	Plunger	1	
5	Plunger Diaphragm	1	
6	O ring 8x4.8	1	
7	O ring 29.74x3.53	2	
8	Solenoid Coil 24VDC Assembly	1	
	Solenoid Harness Not Shown #1 Red; #2 Black	1	
9	Mounting Plate	1	
10	Screw ST3.5x13	6	
11	Solenoid Diaphragm	1	
12	Bolt M5x16	4	
13	Aspirator Cap	1	
14	O ring 40.87x3.53	1	
15	O ring $\Phi$ 14x3	2	
16	Screen, Nozzle	1	05060068
17	O ring 34.52x3.53	1	
18	Aspirator Housing Plug	1	
19	Bolt M5x68	4	
20	95 Clip	1	92380
	<b>Kit, Nozzle/BLFC all Items 21 to 22A + all 26 &amp; 27</b>	1	60010150K
21	Nozzle Black 5s	1	60010154
&	Throat Orange 5s	1	60010156
22	Nozzle Gray 1#	1	60095043
	Throat Gray 1#	1	60095047
	Nozzle purple 2#	1	05040057
	Throat purple 2#	1	05040058
	Nozzle Red 3#	1	60010151
	Throat Red 3#	1	60010157
	Nozzle White 4#	1	60010152
	Throat White 4#	1	60010158
22A	Throat Check ball,71mm	1	5060140
23	95 Brine Elbow	1	60010232
24	O ring (EPDM)25x3	1	60010211
25	95 BLFC Retainer	1	12054
26	BLFC 6# 0.95gpm	1	60010161
	BLFC 7# 1.5gpm	1	60010162
	BLFC 1# 2.0gpm	1	12053
	BLFC 2# 2.5gpm	1	05040077
	BLFC 3# 3.0gpm	1	05040078
	Brine line connectors		
27 Not shown	Connector 1/2" BSPx3/8" tube	1	60010217
27 Not shown	Connector 1/2" BSPx1/2" tube	1	60010230
Not shown	Tee,nylon 3/8" tube	1	80033203
Not shown	Tee,nylon 1/2" tube	1	80033212
Not Shown	Silicone grease 8oz tube	1	1014081

105 modified-sub assy.xlsx

**Piston / Seal / Spacer (Lantern Ring) Replacement**

**Section 10.3.2**

- See section 9.0 to 9.3 for seal replacement procedures.

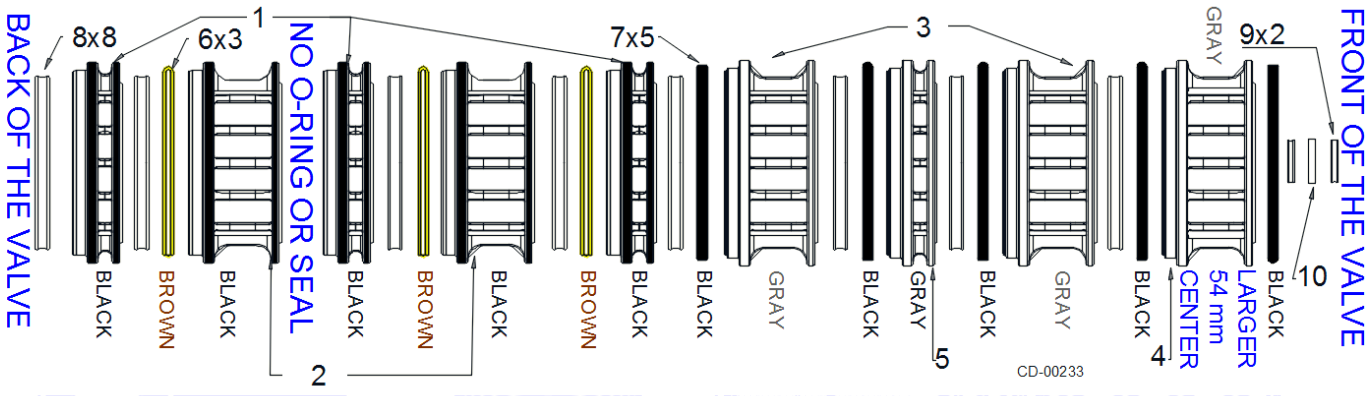
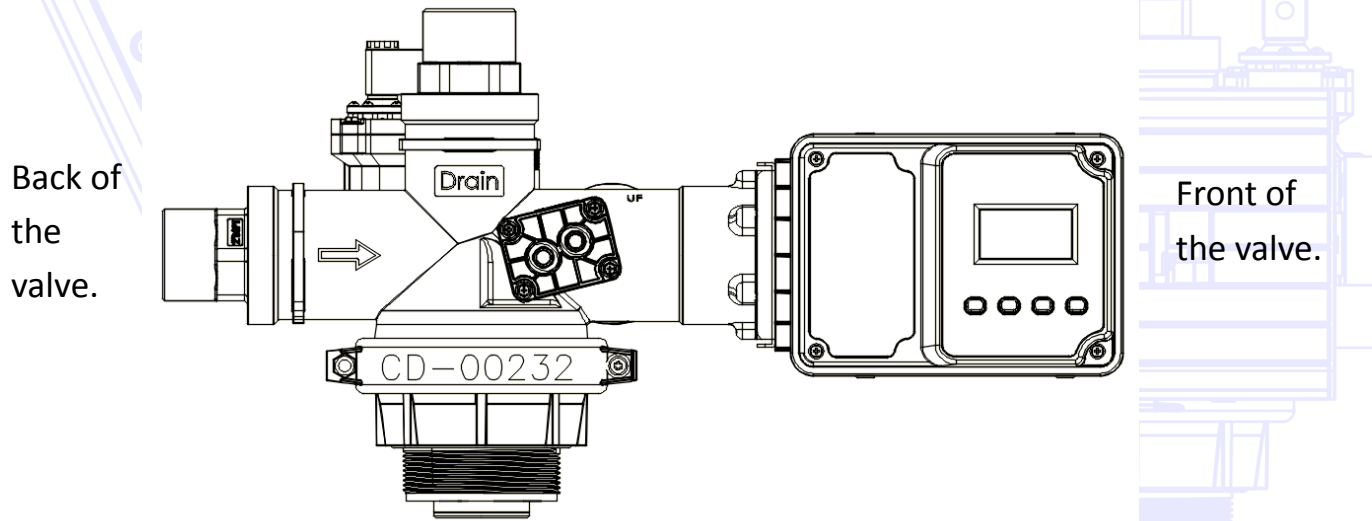

<b>Internal Rebuild Kit - includes items 1 to 10 only #05060134M</b>			
<b>10.3.2</b>	<b>Item</b>	<b>Description</b>	<b>Quantity</b>
1	Lantern ring I (spacer)	Black 50 mm	3
2	Lantern ring II (spacer)	Black 50 mm	2
3	Lantern ring III (spacer)	Gray 50 mm	2
4	Lantern ring V (spacer)	Gray 54 mm	1
5	Lantern ring IV (spacer)	Gray 50 mm	1
6	O ring	59.92x3.53 Brown	3
7	O ring	63.09x3.53 Black	5
8	Quad ring	50.17x5.33 Black	2
9	Quad ring	12.37x2.62	1
10	Quad ring gasket		1
Sold separately		<b>Stuffer/puller tool (required when changing internals) #70020033</b>	

105 modified-sub assy.xlsx

105 MTS Series Control Valve





**105 Internal Motor Bracket Assembly**

**Section 10.3.3**

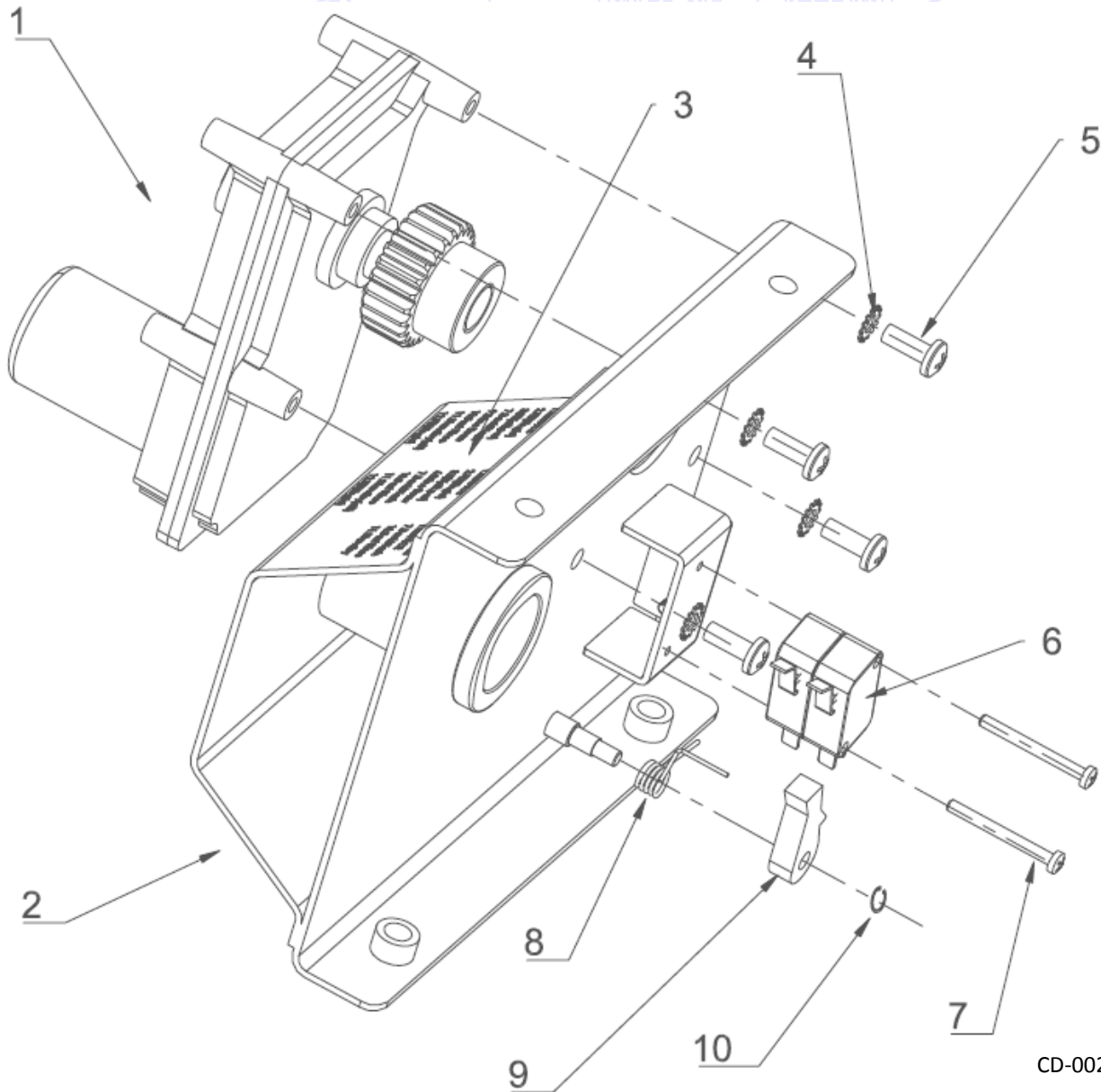

CD-00233

10.3.3 Item	Description	Quantity	
1	Motor assembly c/w gear	1	05060102
2	Inner Bracket	1	
3	Decal	1	
<b>62000607-K Kit,105 microswitch 02170297</b>			
4	10# washer	4	
5	Screw #10-32UNF0.5"	4	
6	Micro-switch EWS	2	
7	SCREW,MICROSWITCH	2	
8	Spring, Anti Reverse	1	
9	Anti Reverse pawl	1	
10	Snap clip 3.5	1	
Not Shown	Cable, Micro Switch,	1	
Complete assembly items 1 to 10			05060124

105 modified-sub assy.xlsx

105 Drain Line Flow Control Assembly (DLFC)

Section 10.3.4

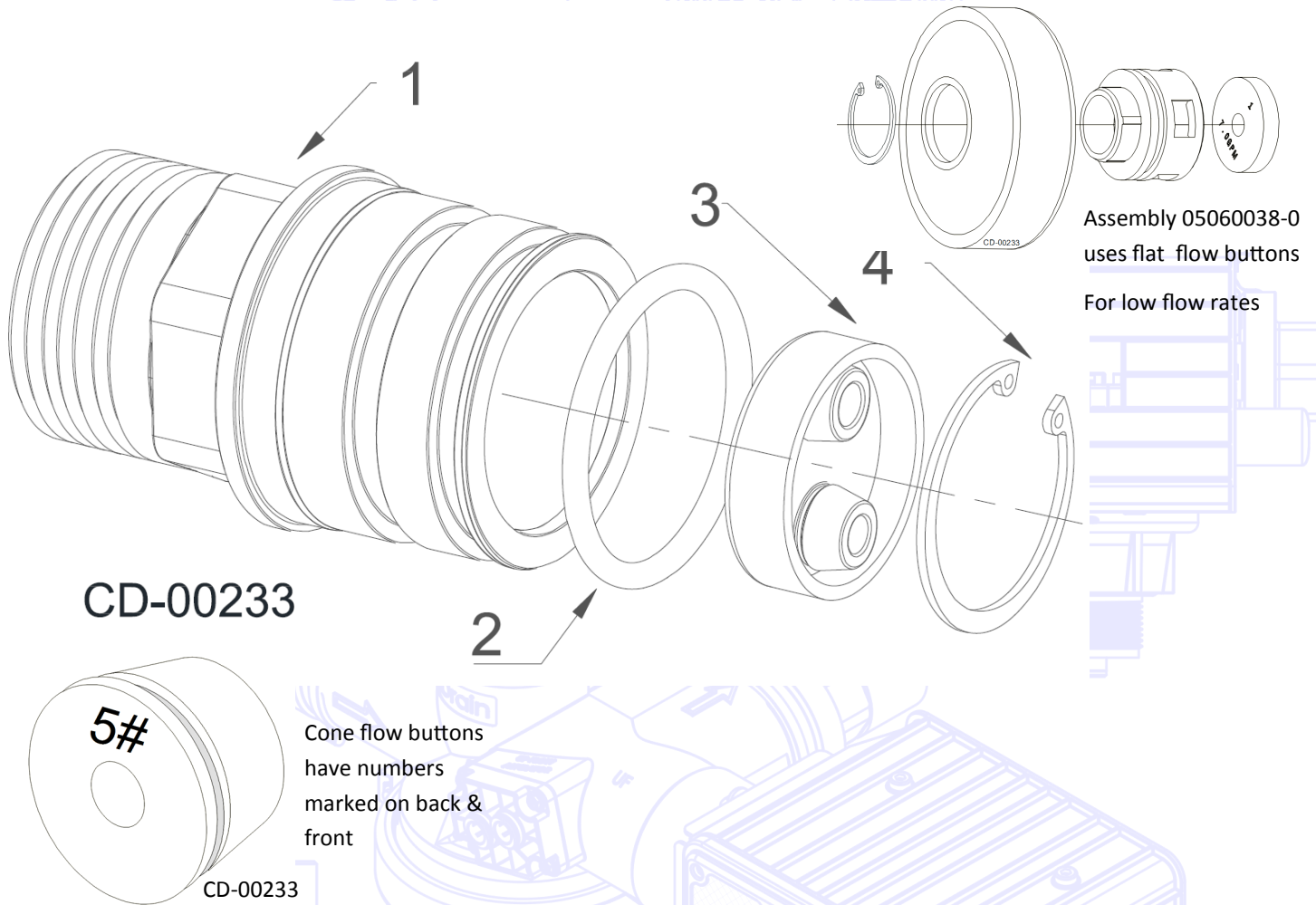

Item	PART NUMBER	Description		Qty
1	05060031	2.0" NPT adapter	105 Valve	1
1	05060034	1.5" NPT adapter	105 Valve	1
2	05060058	O ring 56.52x5.33	105 Valve	1
3	05060127	DLFC 1# ASM-12gpm	105 Valve	1
	05060128	DLFC 2# ASM-15gpm	105 Valve	1
	05060129	DLFC 3# ASM-20gpm	105 Valve	1
	05060130	DLFC 4# ASM-30gpm	105 Valve	1
	05060131	DLFC 5# ASM-40gpm	105 Valve	1
	05060132	DLFC 6# ASM-56gpm	105 Valve	1
4	05060077	Snap clip Φ52	105 Valve	1
	05060038-0	DLFC PlugPlate Using Flat Flow Buttons		
	05060038C	DLFC,PlugPlate105V 1Hole	No Plug 105 valve 2"Dia	
	05060038B	DLFC,PlugPlate105V 2Hole	No Plugs 105 valve 2"Dia	
	05060038	DLFC,PlugPlate105V 4Hole	No Plugs 105 valve 2"Dia	
	05060095	DLFC,Flow Plug 8gpm-#4	105valve 0.6"Diameter.3H	
	05060096	DLFC,Flow Plug 12gpm-#5	105valve 0.9"Diameter.6H	
	05060097	DLFC,Flow Plug 15gpm-#6	105valve 0.9"Diameter.6H	
	05060126	DLFC,Flow Plug 20gpm-#7	105valve 0.9"Diameter.6H	

**105 Outlet Adapter C/W Meter Assembly**

**Section 10.3.5**

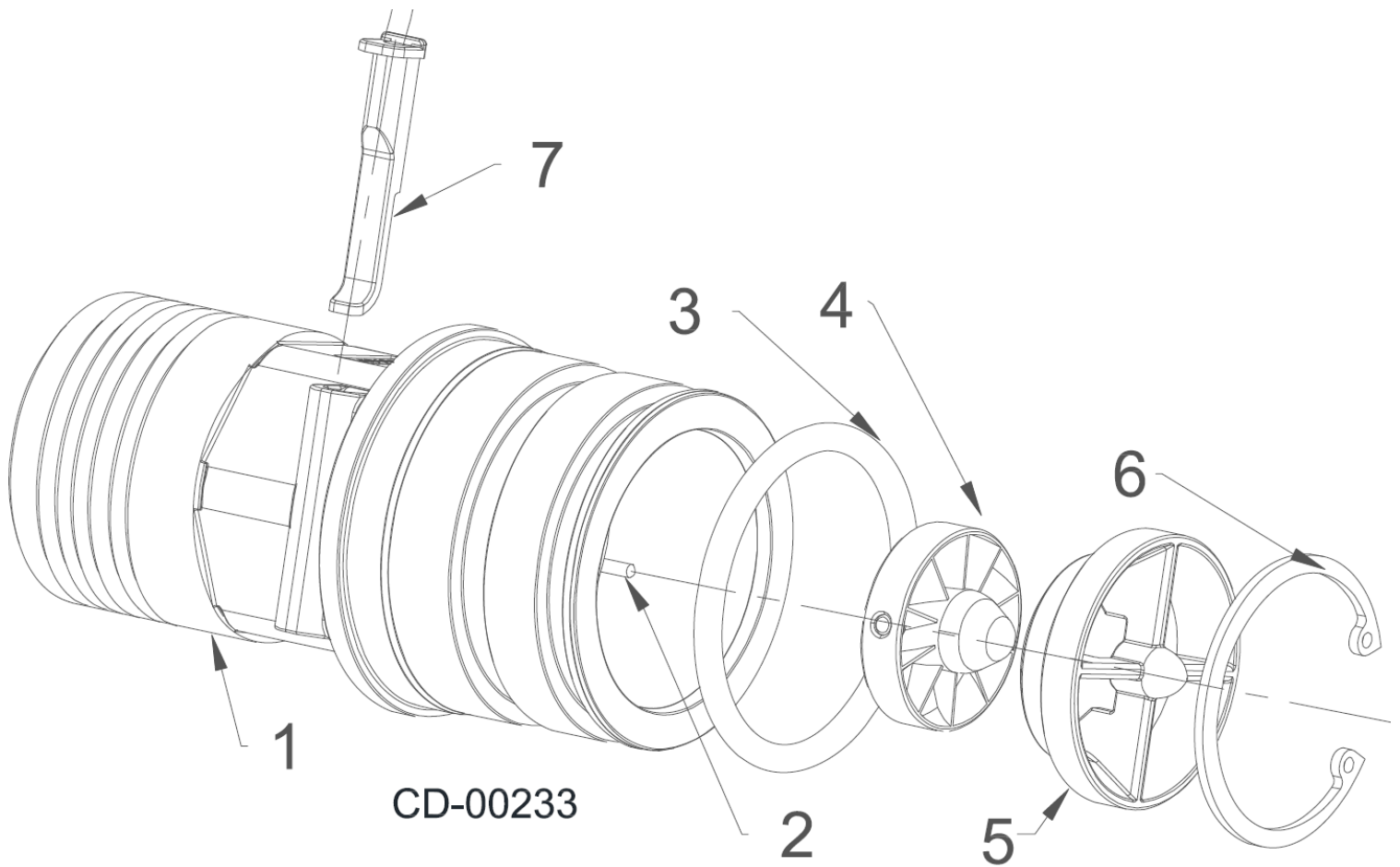

<i>Item</i>	<i>Description</i>	Quantity	Part #
	2" complete meter assembly (parts 1 to 6)	1	05060117
	1.5" complete meter assembly (parts 1 to 6)	1	05060119
1	2.0" NPT Outlet	1	
	1.5" NPT Outlet	1	
2	Turbine shaft	1	
3	O ring 56.52x5.33	1	
4	Turbine Assembly	1	
5	Turbine Nozzle	1	
6	Snap clip $\Phi$ 52	1	
7	Turbine meter cable	1	05060122



**Circuit Boards, Controllers & Cables**

**Section 10.3.6**

- All circuit board connections are color coded.

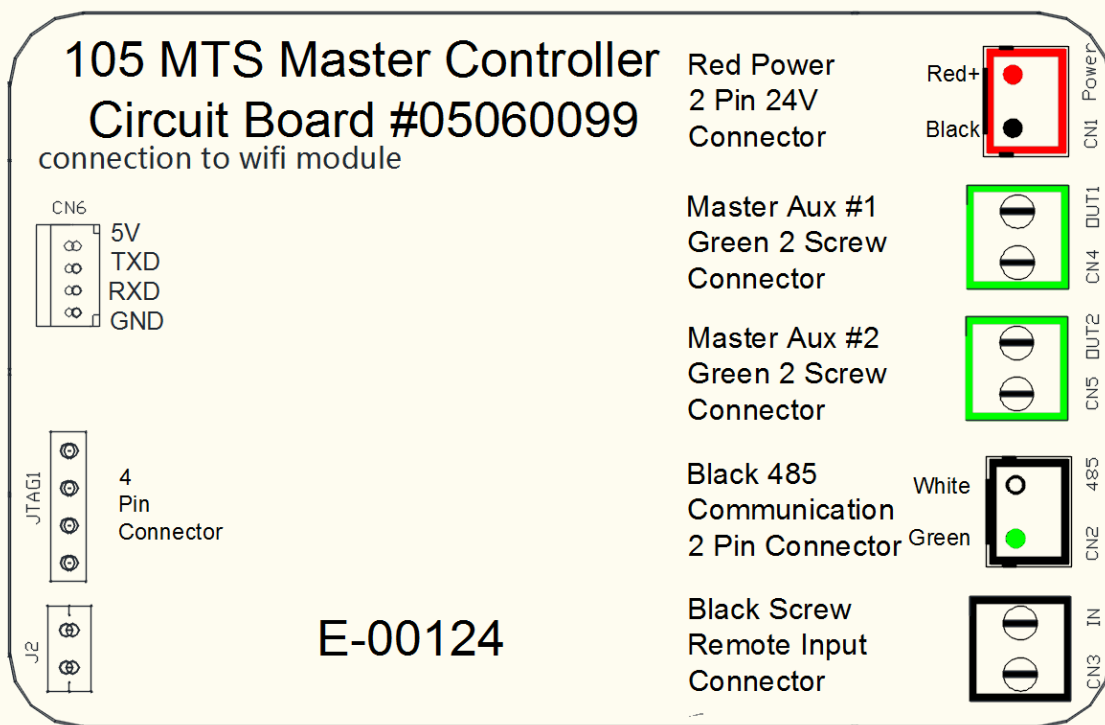
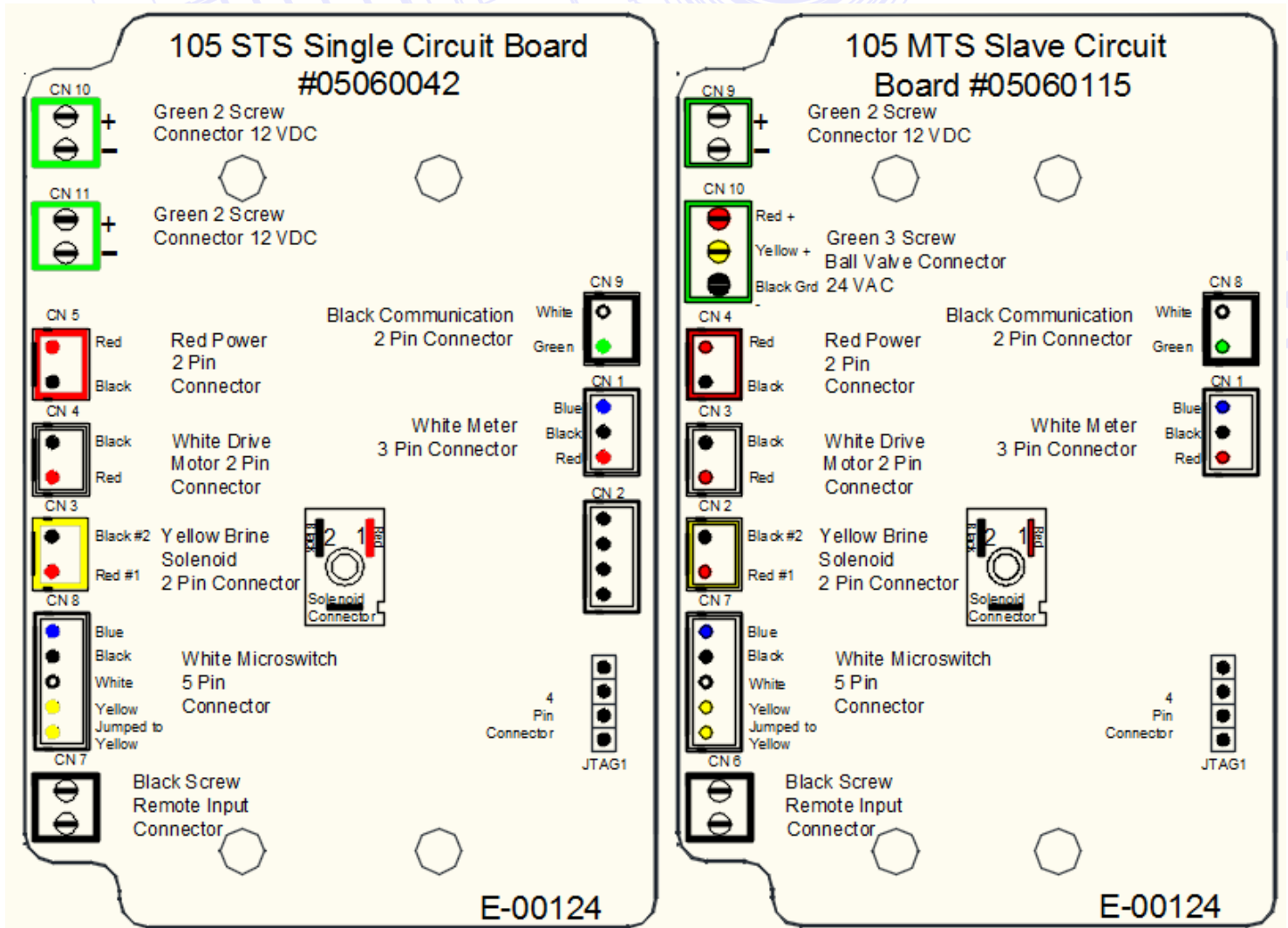

## Circuit Boards, Controllers &amp; Cables

## Section 10.3.6

Controllers, Circuit Boards and Cables		
10010130	MTSB 105 Controller c/w Transformer & One Communication Cable	
-	MTSB 105 Controller Circuit Board (PCB) Use above	
05060115	105 Slave Valve Circuit Board (PCB)	
05060042	105 STS Single Valve Circuit Board (PCB)	
05060122	Cable, Meter to 105 Circuit	Board
05060121	Cable, Motor, 105 Valve 2W	Red Black w White Clip
05060123	Cable, Micro switch 105	Harness 4 wire
05060120	Cable, Solenoid, 105 2Wire	Harness RedBlack-YellowC
70011496 *	Connector, Only 4Pin Female	No Wire
12100064 *	Cable, Power Connection 105	Valve Black & Red 2 Wire
12100064B *	Cable, Communication 105	White Green B Clip 2Wire
60010197-1	Cable, Communication 105	4Pin Male-118" Long
11040071	Transformer MTS/ STS	24 VDC 3 Amp
05060154	Connector, MTS, 2 Pin Male To Transformer	
02170281	Harness, Wiring, MTS Controller	2pin & 4 pin
97000988	Cable, 3 Pin Female with wire #1Brown (red), #2Black, #3Blue(white)	
*	4 pin to circuit board connector use 02170281 & remove the 2 pin connector. Or use parts above with * (soldering required)	

105 Part Numbers.xlsx

**Media**

**Section 10.4**

- Replacement media bed part numbers c/w shipping weight. Beds are complete with support bed gravel.
- For media break down and media loading, see section 5.

Softener Size	Part Number	Ft <sup>3</sup> Resin	Weight	
			LBS	KG
90	410003	3	226	103
120	410004	4	278	126
150	410005	5	345	157
180	410006	6	402	183
210	410007	7	454	206
240	410008	8	526	239
270	410009	9	578	263
300	410010	10	630	286
360	410012	12	774	352
390	410013	13	826	375
450	410015	15	930	423

**Brine Tank Assemblies**

**Section 10.5**

55010033	Safety float for BTR 200 brine tanks 3/8"
55010025	BRT 200 legs 5 legs
55010042	BRT 200 Extension (5 extensions per level- 4 levels max)
55010040	BTR 200 Grid Plate
30100007	Safety float all JSY tanks 1/2" or pipe on site
60050610	Brine well for all jsy brine tanks 5.5"dia. X 54"L
60010005	Over flow adapter
PE-12-EI-0500F-N	3/8" brine line tubing 500 ft roll (specify length when ordering)
PE-16-GI-0250F-N	1/2" brine line tubing 250 ft roll (specify length when ordering)
30020032-4	BTR Brine tank assembly 90, 120 & 150 Softeners (Remove leg extensions as required)
55020015	Brine tank assembly JSY 350 - 7" Grid Min Salting 28 lbs Max 72 lbs
55020016	Brine tank assembly JSY 500 - 7" Grid Min Salting 41 lbs Max 110 lbs
55020017	Brine tank assembly JSY 750 - 9" Grid Min Salting 58 lbs Max 140
DND Master Project-FHFVMS MANUALCOMPONENTS.xlsx	

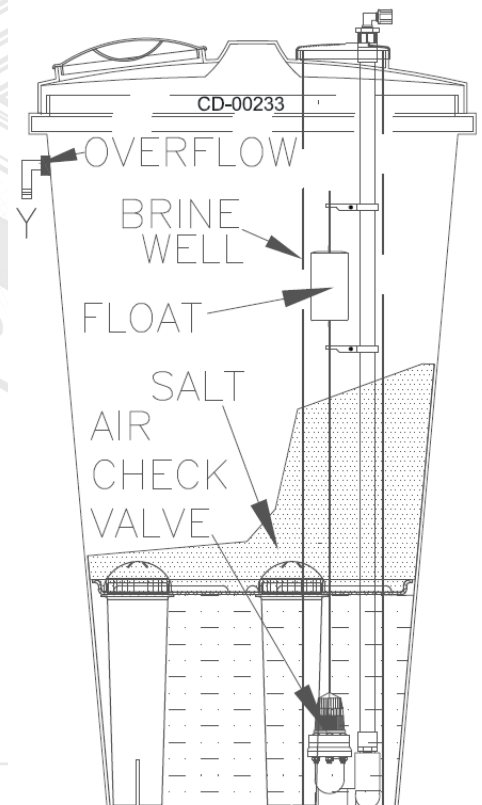



## Troubleshooting

## Section 11

Issue	Possible Cause	Possible Solution
1. Unit fails to initiate a regeneration cycle.	A. No power supply. B. Meter get stuck or breakdown. C. Defective circuit board.	A. Check electrical service, fuse, etc. B. Check and replace the impeller or the meter cable. C. Replace the circuit board.
2. Outlet Water is hard.	A. By-pass valve open. B. Out of salt in brine tank. C. Plugged injector / screen. D. Shortage of Refill water into brine tank. E. Leak between valve and central tube. F. Internal valve leak.	A. Close by-pass valve B. Add salt to tank, keep the salt above the water C. Clean injector and screen. D. Check the refill time; If brine line got stuck, clean it. E. Check if central tube is cracked or O-ring is damaged. Replace faulty parts. F. Replace valve seals, spacer, and piston assembly.
3. Salt usage is high.	A. Incorrect salt consumption settings. B. Too much water in the brine tank.	A. Check the duration time setting of brine draw and refill. B. Take the issue 7 as a reference.
4. Higher pressure drop	A. Iron or scale build up in line feeding unit. B. Iron build up inside valve or tank. C. Inlet of control plugged due to foreign material as a result of plumbing.	A. Clean pipes , add iron pre-filter. B. Clean control valve and add resin cleaner to clean bed. Increase regeneration frequency. C. Take the piston out and clean the control valve.
5. Resin leakage in drain line.	A. Air in water system. B. Incorrect drain line flow control (DLFC) button.	A. Check well system for proper air eliminator control. B . Check for proper flow rate.
6. Iron material in the treated water	A. Resin contaminated by the iron.	A. Clean the resin, check the backwash, brine draw, refill. Increase the frequency of regeneration and backwash duration time.
7. Too much water in brine tank.	A. Plugged DLFC. B. Plugged injector or screen. C. Defective circuit board. D. Foreign material in brine valve. E. Foreign material in brine draw tube.	A. Clean the DLFC. B. Clean the injector or screen. C. Replace the circuit board. D. Clean the brine valve. E. clean the brine draw tube and the BLFC.

## Troubleshooting

## Section 11

8. Unit fails to draw brine.	<p>A. Drain line flow control is plugged.</p> <p>B. Injector is plugged.</p> <p>C. Screen is plugged.</p> <p>D. Inlet pressure too low.</p> <p>E. Internal valve leak.</p>	<p>A. Clean parts.</p> <p>B. Clean parts.</p> <p>C. Clean parts.</p> <p>D. Increase pressure. (the minimum working pressure is 30PSI)</p> <p>E. Replace seals, spacers, and piston assembly.</p>
9. Valve motor continuously run	<p>A. Microswitch or the drive gear of piston is faulty.</p> <p>B. Defective circuit board.</p>	<p>A. See 2.4 Electrical trouble shooting.</p> <p>B. Replace the circuit board.</p>
10. Drain continuously	<p>A. Particle material block in control valve.</p> <p>B. Internal leak.</p> <p>C. The drive gear of power head got stuck.</p> <p>D. Defective circuit board.</p>	<p>A. Take the piston assembly out, clean the foreign material, check each steps of regeneration work well.</p> <p>B. Replace seals, spacers, and piston assembly.</p> <p>C. Check, clean or replace the drive gear assembly.</p> <p>D. Replace the circuit board.</p>
11. Refill continuously	<p>A. Solenoid Diaphragm blocked in signal hole</p> <p>B. lower pressure supply</p> <p>C. Too Small BLFC restrict.</p> <p>D. Defective circuit board.</p>	<p>A. take out and clean diaphragm.</p> <p>B. Increase pressure. (the minimum working pressure is 30PSI)</p> <p>C. Replace for a bigger size BLFC</p> <p>D. Replace the circuit board.</p>



### Tank 3# Error E2 Alarm !

E1: The harness of micro switch is not plugged or loose when Power turn on.  
E2: Motor can't find right position in 10 mins

Press Any key to Exit

### 5. PCB Trouble shooting :

At "Main display" page, inactivated Gray color of the Tank icon caused by a bad communication cables or connection or wrong slave valve setup.

Alarm page and beeping as right:

E1: Check the micro switch cable or harness connection to PCB then plug power on again.

E2: Check all include slave PCB/ wire/motor and valve piston movement which can cause failure of positioning.

**Commercial Softener & Filter Unit Warranty**

Products manufactured by Canature WaterGroup™ are warranted to be free from defects in materials and workmanship where properly installed, operated and maintained. The length of the product warranties vary as per below

**WARRANTY TABLE FOR ASSEMBLED UNITS**

<b>Fiberglass tanks 14”-63” in diameter or larger</b>	<b>5Years**</b>
<b>Control Valves &amp; Electronics</b>	<b>5 Years*</b>
<b>Diaphragm Valves, Meters &amp; Electric Ball Valves</b>	<b>1 Year</b>
<b>Brine Tanks And Internal Assemblies</b>	<b>1 Year*</b>
<b>Media</b>	<b>Limited to warranty provided by original manufacturer</b>
<b>Vinylester / Hot Water Application* Max Temp 150F</b>	<b>1 Year</b>
<b>Steel Tanks (epoxy lined)</b>	<b>1Year</b>
<b>All other components +</b>	<b>1 Year ***</b>
<b>*** Components not manufactured by Canature Watergroup are limited to the warranty given by the manufacturer of the component</b>	

**\* Warranty on Control Valve and Parts**

Canature WaterGroup™ will replace any part (except for wear and tear items – media, piston, seals and brine valve) which fails within the time period specified in the chart above from date of manufacture, as indicated by the serial number, provided the failure is due to a defect in material or workmanship. The only exception shall be when proof of purchase or installation is provided and then the warranty period shall be from the date thereof.

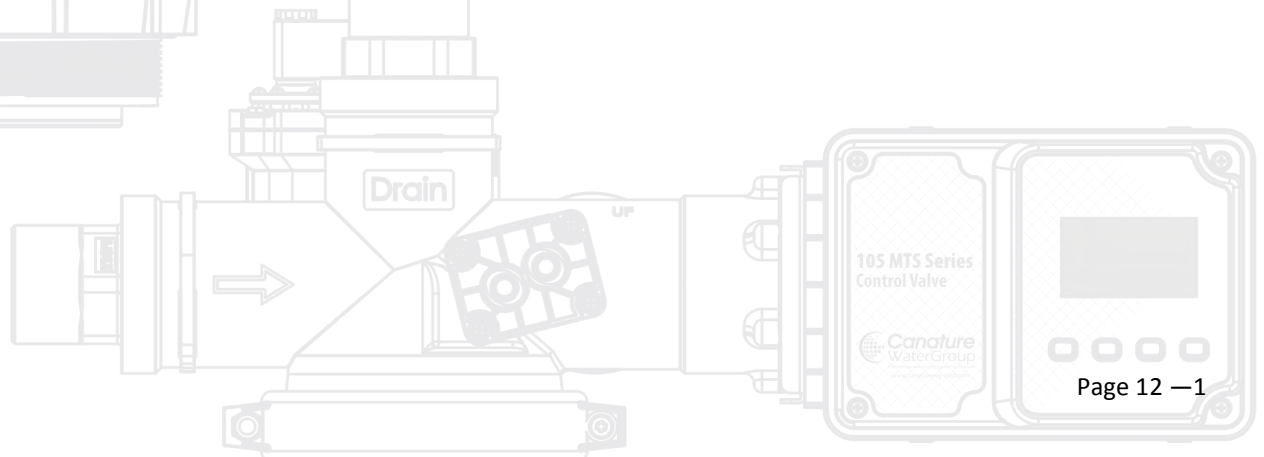



**\*\*Warranty on Mineral Tanks and Brine Tanks:**

Canature WaterGroup™ will provide a replacement mineral tank or brine tank to any original equipment purchaser in possession of a tank that fails within the time outline in the chart above, provided that the system is at all times operated in accordance with specifications and not subject to freezing or vacuum.

\*\*On fiberglass tanks 24" diameter or larger, due to slight expansion and contraction of the tanks, flexible connectors must have been properly installed between the tank openings and rigid piping. Also a vacuum breaker(s) must have been properly installed to protect the tank from vacuum under all conditions. Failure to install flex connectors and/or vacuum breaker(s), or improper installation the tank warranty will be void.

In addition, if the fiberglass tank has a tripod base, it must have been properly and securely attached to the floor. If not done or improperly installed, the tank warranty will be void.

**General Provisions:**

Damage to any part of this commercial system as a result of misuse, misapplication, neglect, alteration, accident, installation or operation contrary to our printed instructions, damage to ion exchange resin and seals caused by chlorine / chloramines in the water supply, damage to internal pistons and seals caused by wear and tear from iron, manganese, sediment and or silt, or damage caused by any force of nature is not covered in this warranty. We will repair or replace defective parts if our warranty department determines it to be defective under the terms of this warranty. Canature WaterGroup™ assumes no responsibility for consequential damage, labor or expense incurred as a result of a defect or failure. Media and Resin coverage is limited to the warranty provided by the original manufacturer.

**Return of Goods:**

An authorization number must be obtained before returning any merchandise. NOTE: All material returned to Canature WaterGroup™ must be returned freight prepaid. Upon inspection, if our warranty department determines the goods to be defective under the terms of this warranty, the warranty shall be limited to the defective parts to be repaired, replaced, or credited at Canature WaterGroup's™ discretion. You pay only freight to return defective parts to our factory and local dealer charges, including but not limited to labor charges, travel and transportation expenses, and handling fees.

Some State & Provincial jurisdictions do not allow limitations on how long an implied warranty lasts, so the above limitation may not apply to you. Similarly, some State & Provincial jurisdictions do not allow exclusion of incidental or consequential damages, so the above limitations or exclusions may not apply to you. This warranty gives you specific legal rights, and you may also have other rights, which vary from jurisdiction to jurisdiction. Consult your authorized Dealer for warranty and service information.

**U.S.A.**  
**9760 Mayflower Park Dr.**  
**Suite 110, Carmel, IN 46032**



**U.S.A.**  
**56 Lightcap Rd.**  
**Pottstown, PA 19464**



**U.S.A.**  
**4645 W. McDowell Rd.**  
**Suite 106 Phoenix, AZ 85035**



**Canada West**  
**855 Park St. Unit 1**  
**Regina, SK S4N 6M1**



**Canada East**  
**490 Pinebush Rd. Unit 1**  
**Cambridge ON N1T 0A5**



**TOLL FREE:1-877-288-9888**

105 MTS Series  
Control Valve

Canature  
WaterGroup  
www.canaturewatergroup.com