

Model (Single)	Capacity		Resin		Salt Usage		Critical Flow USGPM	105			Dimensions		Installation			Shipping Weight lbs	Operating Weight lbs
	@6 lbs/ft3	ft3	@6 lbs/ft3	@10 lbs/ft3	@ 15 PSI	@ 25 PSI		Max Flow To Drain	Mineral Tank	Brine Tank	Height	Depth	Width				
	@10 lbs/ft3	m3	lbs	lbs	USGPM	USGPM		USGPM	in	in	in	in	in				
105MTS 120 -2"	88,000	4	24	40	20	39	56	7	16 x 65	24 x 37	85	31	50	430	1,730		
	108,000	0.11	10.89	18.1	1.26	2.46	3.53	0.44	403 x 1651	610 x 940	2,159	787	1,270	195	785		
105MTS 150 -2"	110,000	5	30	50	25	43	61	9	18 x 65	24 x 37	87	32	52	501	1,901		
	135,000	0.14	13.61	22.7	1.58	2.71	3.85	0.57	475 x 1651	610 x 940	2,210	813	1,321	227	863		
105MTS 180 -2"	132,000	6	36	60	30	47	68	12	21 x 62	29 x 50	87	36	60	623	2,723		
	162,000	0.17	16.33	27.2	1.89	2.97	4.29	0.76	533 x 1575	740 x 1275	2,210	914	1,524	283	1,235		
105MTS 210 -2"	154,000	7	42	70	35	46	66	12	21 x 62	29 x 50	87	36	60	679	2,779		
	189,000	0.20	19.06	31.8	2.21	2.90	4.16	0.76	533 x 1575	740 x 1275	2,210	914	1,524	308	1,261		
105MTS 240 -2"	176,000	8	48	80	40	50	71	15	24 x 72	33 x 53	95	40	67	811	3,711		
	216,000	0.23	21.78	36.3	2.52	3.15	4.48	0.95	610 x 1829	840 x 1335	2,413	1,016	1,702	368	1,684		
105MTS 270 -2"	198,000	9	54	90	45	49	70	15	24 x 72	33 x 53	95	40	67	866	3,766		
	243,000	0.25	24.50	40.8	2.84	3.09	4.42	0.95	610 x 1829	840 x 1335	2,413	1,016	1,702	393	1,709		
105MTS 300 -2"	220,000	10	60	100	48	48	69	15	24 x 72	33 x 53	95	40	67	922	3,822		
	270,000	0.28	27.22	45.4	3.03	3.03	4.35	0.95	610 x 1829	840 x 1335	2,413	1,016	1,702	418	1,734		
105MTS 360 -2"	264,000	12	72	120	50	54	76	25	30 x 72	33 x 53	100	40	74	1,065	4,465		
	324,000	0.34	32.67	54.4	3.15	3.41	4.79	1.58	762 x 1829	840 x 1335	2,540	1,016	1,880	483	2,026		
105MTS 390 -2"	286,000	13	78	130	54	54	76	25	30 x 72	38 x 55	100	44	78	1,179	5,479		
	351,000	0.37	35.39	59.0	3.41	3.41	4.79	1.58	762 x 1829	965 x 1397	2,540	1,118	1,981	535	2,486		
105MTS 450 -2"	330,000	15	90	150	52	52	75	25	30 x 72	38 x 55	100	44	78	1,291	5,591		
	405,000	0.42	40.83	68.1	3.28	3.28	4.73	1.58	762 x 1829	965 x 1397	2,540	1,118	1,981	586	2,537		

LEGEND:

- ☒ ISOLATION VALVE
- ☒ BYPASS VALVE
- ⊕ PRESSURE GAUGE & SAMPLE POINT
- ⊕ OPEN DRAIN
- ⊕ DIAPHRAGM VALVE
- ★ VACUUM BREAKER
- # FLEX CONNECTORS
- ▶ RAW WATER LINES
- ▶ FILTERED/SOFTENED WATER
- ▶ TREATED WATER LINES
- ⊕ ELECTRIC BALL VALVE

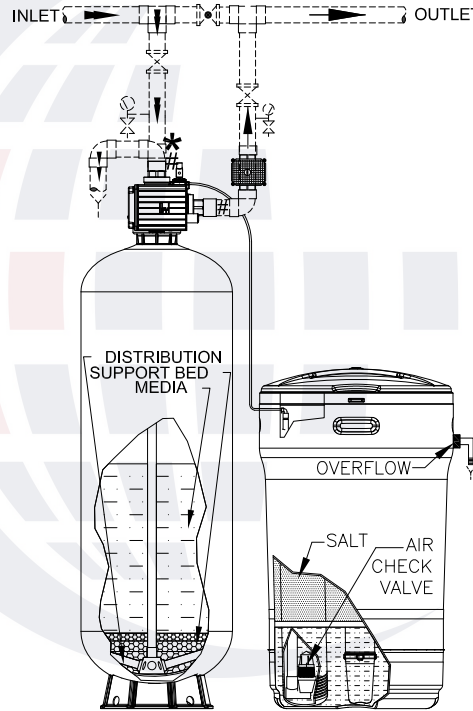

MAIN CONTROLLER



RAW WATER REGENERATION PIPING SHOWN

NOTES:

- SOFTENER(S) EQUIPPED WITH A 105 SERIES ELECTRONIC CONTROL VALVE.
- 2" OR 1.5" NPT CONNECTIONS ARE INTERCHANGEABLE. STANDARD CONNECTION SIZE USED VARIES WITH SOFTENER SIZE (SEE ABOVE TABLE).
- REQUIRES 120 VOLT, 1 PHASE, 60 Hz ELECTRICAL POWER.
- ALL EXTERNAL PIPING, FITTINGS, INTERCONNECTING PIPING, ISOLATION & SAMPLE VALVES AND GAUGES SHOWN BY BROKEN LINES ARE BY OTHERS
- TANKS AND MEDIA ARE NSF APPROVED.
- RECOMMENDED MINIMUM SYSTEM PRESSURE IS 207 kPa (30 PSI) & MAXIMUM SYSTEM PRESSURE IS 690 kPa (100 PSI). MAXIMUM TEMPERATURE IS 38°C (100°F).
- TRIPOD TANKS TO BE SECURELY ATTACHED TO THE FLOOR.
- MAX FLOW TO DRAIN" IS BASED ON WATER TEMPERATURES OF 4°C (40°F).
- FLOOR DRAINS MUST BE SIZED TO CARRY THE MAXIMUM LISTED FLOW TO DRAIN.
- REFER TO THE INSTALLATION AND OPERATION MANUAL FOR FURTHER DETAILS.
- SYSTEM MUST BE INSTALLED TO COMPLY WITH ALL FEDERAL, STATE, PROVINCIAL AND LOCAL CODES.
- MINIMUM FREE SPACE OF 152 mm (6") REQUIRED ABOVE VALVE.
- DUE TO SLIGHT EXPANSION AND CONTRACTION OF MINERAL TANKS, PIPING MUST BE DESIGNED TO ALLOW SOME MOVEMENT AS WELL AS PROTECTED FROM VACUUM. FLEX CONNECTORS AND A VACUUM BREAKER MAY BE REQUIRED.

- IF USING SYSTEM TREATED WATER REGENERATION, THE BALL VALVE MUST BE INSTALLED ON THE INLET INSTEAD OF THE OUTLET.
- NOTE: IF NEGATIVE PRESSURE EXCEEDS 5" HG (17 kPa), AN ADEQUATE VACUUM BREAKER MUST BE PROPERLY INSTALLED. FAILURE TO INSTALL FLEX CONNECTION PROPERLY, OR IMPROPER INSTALLATION OF A VACUUM BREAKER WHEN REQUIRED, WILL VOID THE WARRANTY.
- MULTI-TANK SYSTEMS (MTS):
 - ALL MTS ARE CONTROLLED BY ONE CENTRAL CONTROLLER.
 - SOFTENERS ARE METER INITIATED, RESPONSIVE FLOW SYSTEMS. UNITS ARE AUTOMATICALLY BROUGHT ON-LINE BASED ON TOTAL SYSTEM FLOW RATE.
 - SOFTENERS ARE INTERLOCKED SO ONLY ONE UNIT CAN REGENERATE AT A TIME.
 - BRINE LINES TEED TO ACCOMMODATE SINGLE BRINE TANK ASSEMBLY

MODEL: 105 MTS 150 -2" S8000

105 MTS SINGLE SOFTENER

THIS DOCUMENT CONTAINS INFORMATION WHICH IS PROPRIETARY TO CANATURE WATERGROUP. THE REPRODUCTION, TRANSFER, OR OTHER EXPLOITATION OF ANY INFORMATION CONTAINED HEREIN IS NOT PERMITTED WITHOUT PRIOR WRITTEN APPROVAL OF CANATURE WATERGROUP. THE MANUFACTURER RESERVES THE RIGHT TO MAKE PRODUCT REVISIONS, WHICH MAY DEVIATE FROM THE SPECIFICATIONS AND DESCRIPTIONS STATED HEREIN WITHOUT OBLIGATION TO CHANGE PREVIOUSLY MANUFACTURED PRODUCTS OR TO NOTE THE CHANGE. NOT DRAWN TO THE SCALE UNLESS OTHERWISE SPECIFIED.



Project:	Date: 02/21/2024	Rev
	Dwg# 105 MTS 2"S	