

ICA

AUTOMATIC DOUBLE-CLIPPER



Poly-clip System Exclusive Features

The star indicates features that you will only find at Poly-clip System.

- ★ No one else has it: Robust iris displacer up to caliber 200 mm
- ★ No one else has it: Split magazine rack for ergonomic clip loading

Why clip with ICA?

The ICA is the ideal machine for large calibres and moulded products up to a calibre of 200 mm. Fibrous, collagen and plastic casings can be processed. The innovative iris separator makes the ICA ideal for the production of large volumes like slicer products, moulded ham, even those made of whole muscles.

Air-free slack filling

- Calibres up to 200 mm
- Overspreading up to 300 mm
- Up to 60 cycles per minute in continuous mode
- For large calibres and moulded products
- Innovative iris separator for short, symmetrical sausage shoulders
- Moulded products up to 1.6 m length
- Compact machine for a wide product range
- The global ham machine

Excellence in Clipping



DETAILS



Considerable cost savings: ICA in combination with the TSA 160 automatic sealing machine

Advantages

- Short clip cycles for high-level output
- Innovative iris separator for short, symmetrical sausage shoulders
- Product true to the calibre as the conveyor speed is programmable and infinitely variable
- Low noise operation
- Easy to manoeuvre with two lockable wheels
- Simple machine operation with SAFETY TOUCH – shock-proof, 10" large and easy to clean
- die Produktparameter sind in der Rezepturverwaltung des SAFETY TOUCH abrufbar
- Operator-friendly with individually assignable manual functions, e.g. inching mode
- USB port for data import and export
- Additional safety by two-handed triggering of first clip
- Simple conversion of clip size S 8700 to S 800
- Pneumatic movement of the clip head for reloading of casing
- Casing brake can be adjusted from outside while stuffing

- Electronic hand-wheel for adjustments and setting parameters
- Low air consumption
- Reliable cut of elastic nettings

Quality and hygiene

- Hygienic design, easy to clean, smooth stainless steel surfaces
- Conveyor belt contact surface is made of stainless steel and is smooth with rounded embossments

Maintenance

- Optimum access for maintenance work

Equipment options

- Selection shaping roller for automatic spreading of the meat in the casing
- Consumption-oriented central lubrication for maximum reliability and service life
- Air-free slack filling of moulded products by overspreading

up to 300 mm, with servo control, adjustable and programmable as product parameters

- Swirl brake with crown filling horn for consistently clear and grainy raw sausage texture, possible reduction of production costs due to shortened natural curing time
- Protective guard with sliding grate made of stainless steel
- Twin turret
- Automatic looper GSA 20
- Casing end switch
- S-clips on spool – 1,300 sausages without reloading
- Filling horns diameter 24, 28, 36, 48, 60, 70, 76, 80, 85 and 100 mm
- Servo-supported clip pressure setting, e.g. for sensitive fibrous casings, can be saved as product parameter
- Portioning or length filling
- Telescope conveyor belt 1.3 m long
- Roller extension to conveyor belt for 1.6 m long sausages

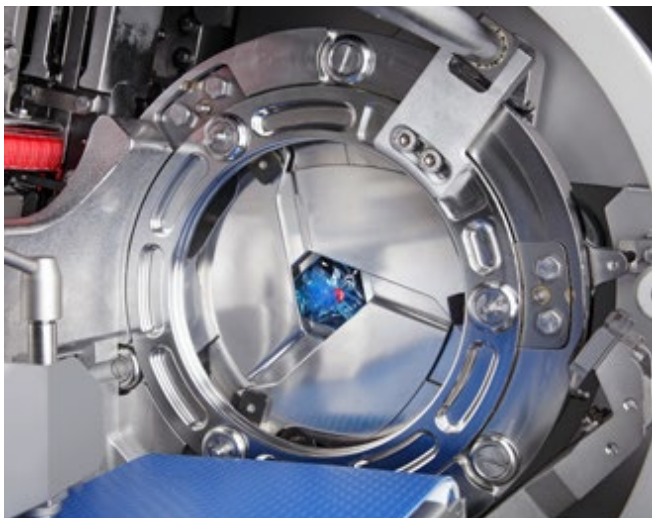

The iris separator ensures clean sausage ends and careful portio-

- Automatic adjustment of conveyor belt speed
- Pneumatic dry sausage brake
- Second control panel at end of conveyor belt
- Vacuum system for air-free filling of large calibres
- Pneumatically movable casing brake holder
- WS Food Standard interface for operational data acquisition
- Intelligent Filler Clipper (IFC) Interface upon request

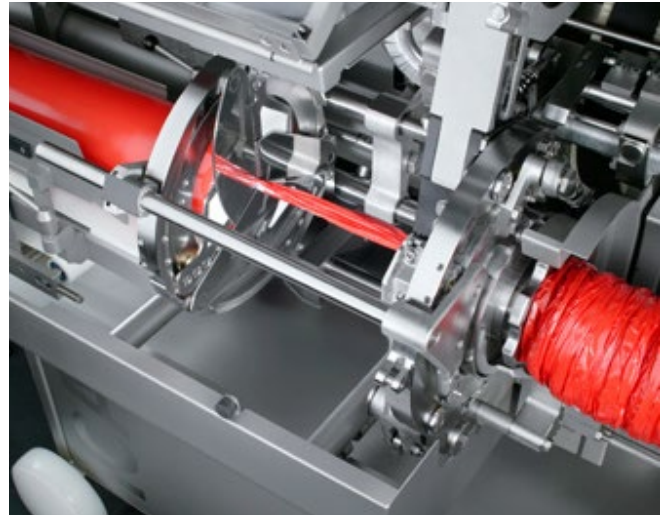

The overspread ensures the air-free loose filling of moulded products.

Possible combinations

ES 5000

- Labelling system for marking and traceability

TSA 160

- Seals ready-to-fill tube from flat roll stock film in-line

Consumables

- S-Clip for calibres up to 160 mm: S 8740, S 8744, S 8748
- S-Clip for calibres up to 200 mm: S 840, S 844, S 848, S 854
- Loops: GS 20, GS 20 S3, GS 20 X

Function and operation

The ICA is connected mechanically to filling machines, including ham pumps and synchronized electrically. After the filler has discharged the portion, the iris separator powerfully encloses the casing and separates whole muscles without damage to the casing. The ICA is equipped with the tried-and-





The safety glass provides an optimal view for the operator.



Clip System Solutions

The complete system of clipping machine, clips and loops from a single source ensures efficient and trouble-free production. Original clips from Poly-clip System guarantee the highest quality. Manufacturing is subject to the most rigorous quality controls. Certified in accordance with ISO 22000 and ISO 9001 they are designed to suit the production process perfectly. With its food-proof safety coating certified by the SGS INSTITUT FRESENIUS, Poly-clip SAFE-COAT technology ensures trouble-free production and if required a no-worry product warranty. Poly-clip System is the world's leading provider of clip system solutions.

tested clip distance of 51 mm. The PC control allows a very fast and accurate signal processing. On the SAFETY TOUCH display the diagnostic system provides a direct and clear indication of the clipping machine's operational status as well an analysis of filling and clipping times. Deviations from the recipe parameters saved in SAFETY TOUCH are monitored. The operator is intuitively guided through the flat menu structure of the SAFETY TOUCH by means of self-explaining pictograms. Operator, set-up and service levels are kept clearly separated and are password protected. A continuous process monitoring is offered by the high degree of automation.



TECHNICAL DATA

Front view (dimension in mm)

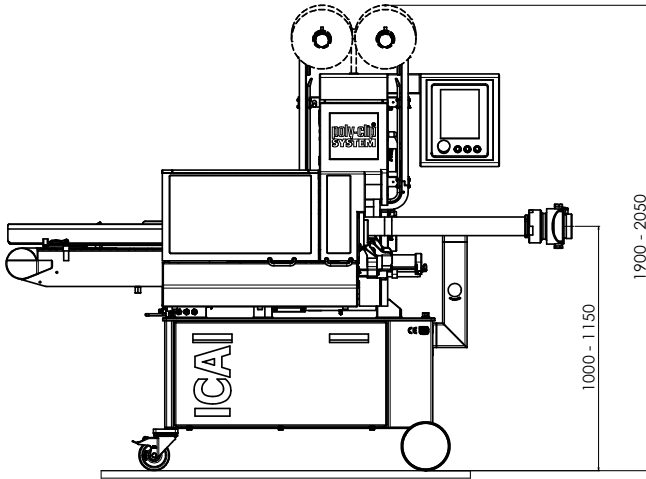

Top view (dimension in mm)

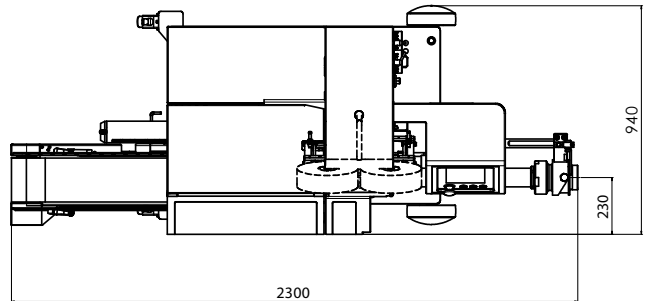

Width
2.300 mm

Depth
940 mm

Height
**1.900 –
2.050 mm**

Weight
850 kg

Three-phase current connection
**200 – 240 VAC,
380 – 460 VAC,
50/60 Hz**

Power input
2,8 kW

Fuse connection
16 A

Compressed air
**5 – 7 bar /
0,5 – 0,7 MPa**

Air consumption
0,6 NL/Cycle

Air consumption incl. over-spreading
20 NL/Cycle

Air consumption incl. GSA
1 NL/Cycle

Poly-clip System GmbH & Co. KG | Niedeckerstraße 1 | D-65795 Hattersheim a. M. | +49 6190 8886-0 | contact@polyclip.de | polyclip.com

Excellence in Clipping



Poly-clip System GmbH & Co. KG | Niedeckerstraße 1 | D-65795 Hattersheim a. M. | +49 6190 8886-0 | contact@polyclip.de | polyclip.com