

PRESIDENT®

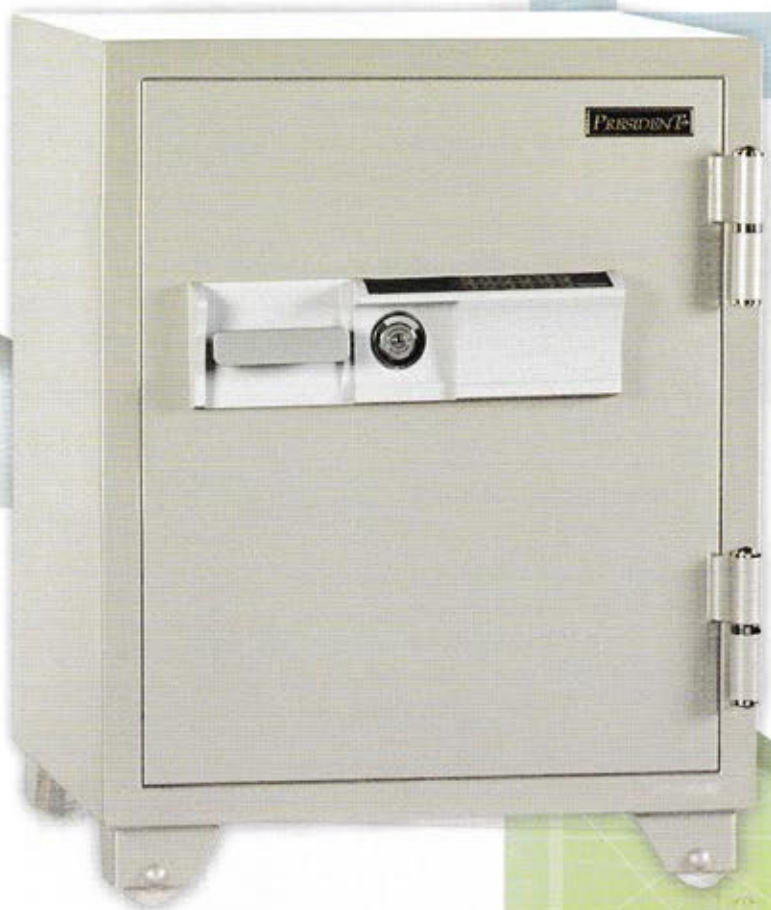

**FIRE RESISTANT
SUPERIOR
SAFE**

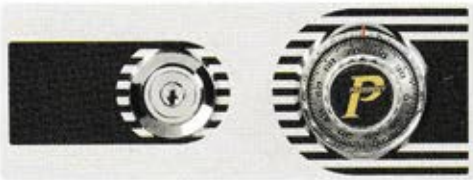

COMBINATION LOCK

UNIT : MM.

SMALL SAFE

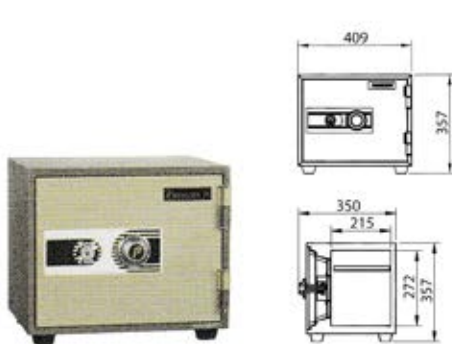

LS1

OUTSIDE	W409xD350xH357
INSIDE	W352xD215xH272
CAPACITY	20 LITRES
NET WEIGHT	28 KG
ACCESSORY	1 TRAY
FIRE RATING	1 HR

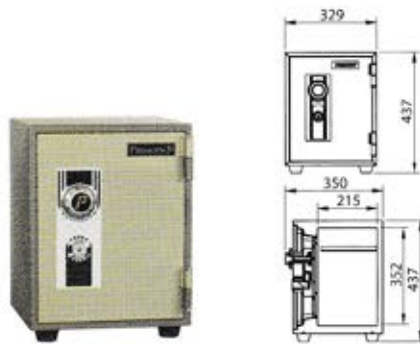

LS2

OUTSIDE	W329xD350xH437
INSIDE	W272xD215xH352
CAPACITY	20 LITRES
NET WEIGHT	28 KG
ACCESSORY	1 TRAY
FIRE RATING	1 HR

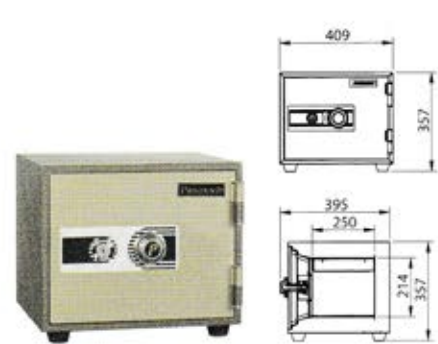

MS1

OUTSIDE	W409xD395xH357
INSIDE	W294xD250xH214
CAPACITY	16 LITRES
NET WEIGHT	40 KG
ACCESSORY	1 TRAY
FIRE RATING	1 HR

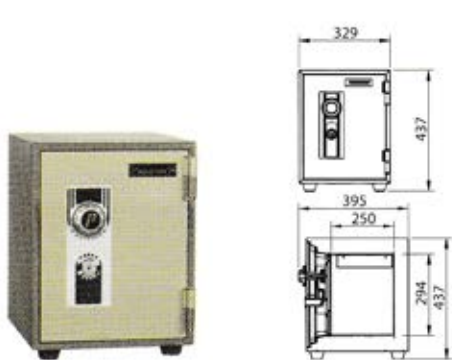

MS2

OUTSIDE	W329xD395xH437
INSIDE	W214xD250xH294
CAPACITY	16 LITRES
NET WEIGHT	40 KG
ACCESSORY	1 TRAY
FIRE RATING	1 HR

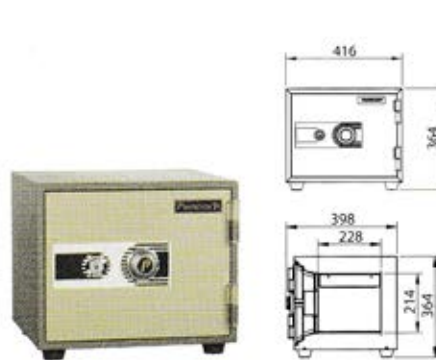

SS42L

OUTSIDE	W416xD398xH364
INSIDE	W294xD228xH214
CAPACITY	20 LITRES
NET WEIGHT	42 KG
ACCESSORY	1 TRAY
FIRE RATING	1 HR



SS42V

OUTSIDE	W336xD398xH444
INSIDE	W214xD228xH294
CAPACITY	20 LITRES
NET WEIGHT	42 KG
ACCESSORY	1 TRAY
FIRE RATING	1 HR

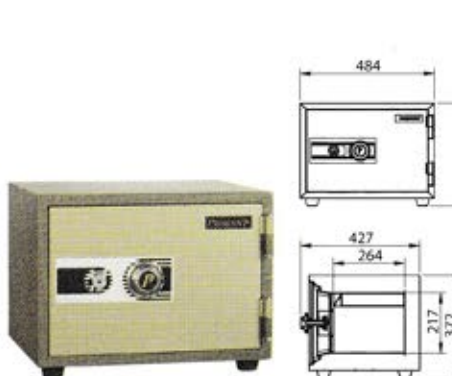

SS1

OUTSIDE	W484xD427xH372
INSIDE	W357xD264xH217
CAPACITY	20 LITRES
NET WEIGHT	50 KG
ACCESSORY	1 TRAY
FIRE RATING	1 HR



SS2

OUTSIDE	W344xD427xH512
INSIDE	W217xD264xH357
CAPACITY	20 LITRES
NET WEIGHT	50 KG
ACCESSORY	1 TRAY
FIRE RATING	1 HR

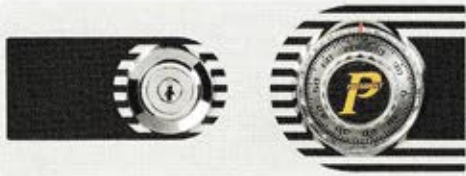

COMBINATION LOCK

หน่วย : มม.

MEDIUM SAFE

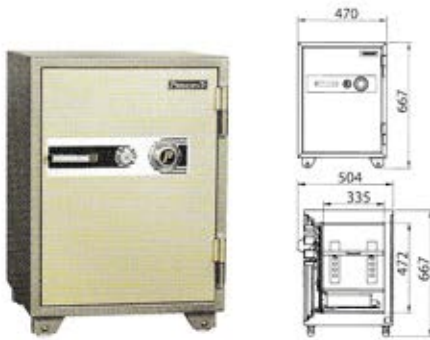

SM

OUTSIDE W470xD504xH667
 INSIDE W332xD335xH472
 CAPACITY 52 LITRES
 NET WEIGHT 105 KG
 ACCESSORY 1 SHELF
 FIRE RATEING 2 HR

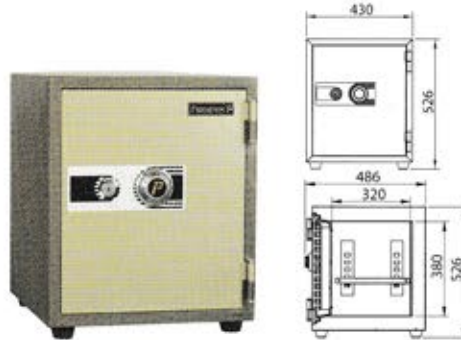

SS70

OUTSIDE W430xD486xH526
 INSIDE W312xD320xH380
 CAPACITY 38 LITRES
 NET WEIGHT 70 KG
 ACCESSORY 1 SHELF
 FIRE RATEING 1 HR

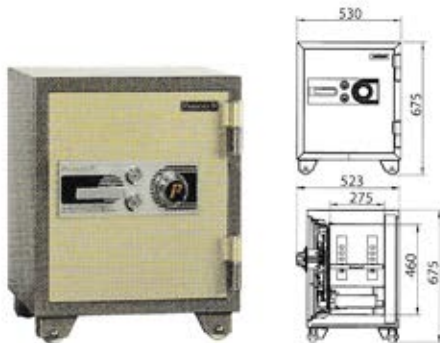

SB20

OUTSIDE W530xD523xH675
 INSIDE W392xD275xH460
 CAPACITY 50 LITRES
 NET WEIGHT 110 KG
 ACCESSORY 1 SHELF
 FIRE RATEING 2 HR

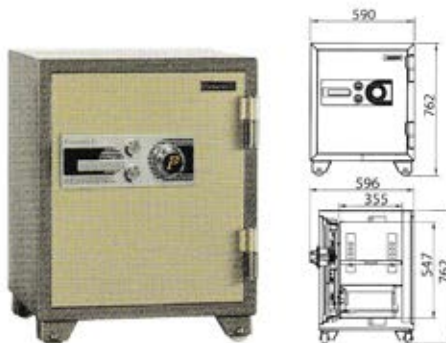

SB30

OUTSIDE W590xD596xH762
 INSIDE W450xD355xH547
 CAPACITY 87 LITRES
 NET WEIGHT 155 KG
 ACCESSORY 1 SHELF
 FIRE RATEING 2 HR

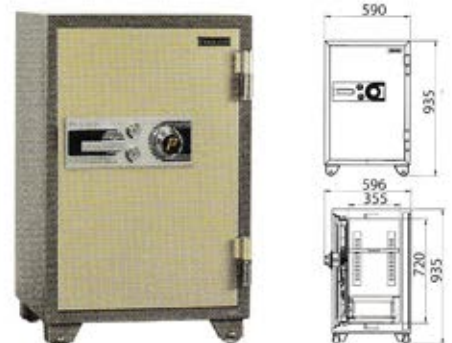

SB40

OUTSIDE W590xD596xH935
 INSIDE W450xD355xH720
 CAPACITY 115 LITRES
 NET WEIGHT 190 KG
 ACCESSORY 1 SHELF
 FIRE RATEING 2 HR

BIG SAFE

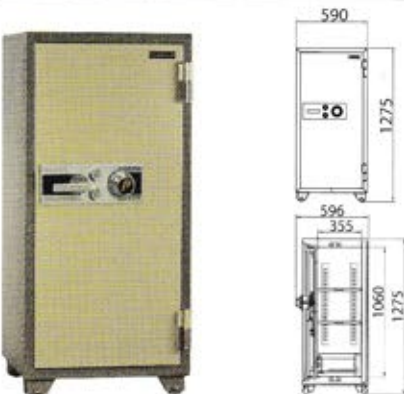

SB50

OUTSIDE W590xD596xH1275
 INSIDE W450xD355xH1060
 CAPACITY 169 LITRES
 NET WEIGHT 250 KG
 ACCESSORY 2 SHELVES
 FIRE RATEING 2 HR

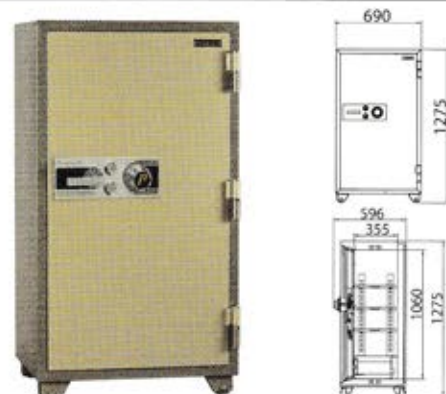

SB60

OUTSIDE W690xD596xH1275
 INSIDE W550xD355xH1060
 CAPACITY 207 LITRES
 NET WEIGHT 295 KG
 ACCESSORY 3 SHELVES
 FIRE RATEING 2 HR

COMBINATION LOCK

หน่วย : มม.

LARGE SAFE

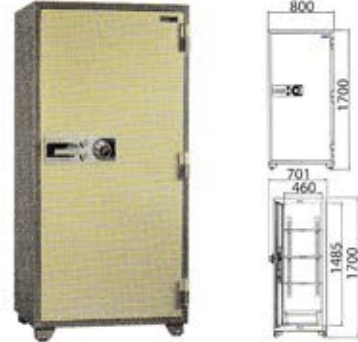
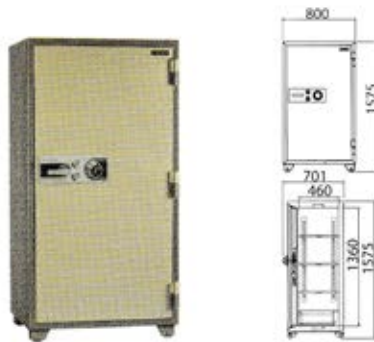
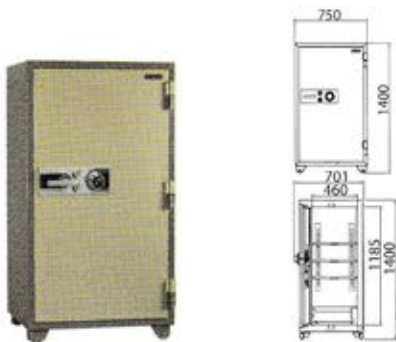

SB70

OUTSIZE W750xD701xH1400
INSIDE W610xD460xH1185
CAPACITY 332 LITRES
NET WEIGHT 370 KG
ACCESSORY 3 SHELVES
FIRE RATEING 2 HR

SB80

OUTSIZE W800xD701xH1575
INSIDE W660xD460xH1360
CAPACITY 413 LITRES
NET WEIGHT 460 KG
ACCESSORY 3 SHELVES
FIRE RATEING 2 HR

SB90

OUTSIZE W800xD701xH1700
INSIDE W660xD460xH1485
CAPACITY 451 LITRES
NET WEIGHT 495 KG
ACCESSORY 3 SHELVES
FIRE RATEING 2 HR

TWO DOOR SAFE

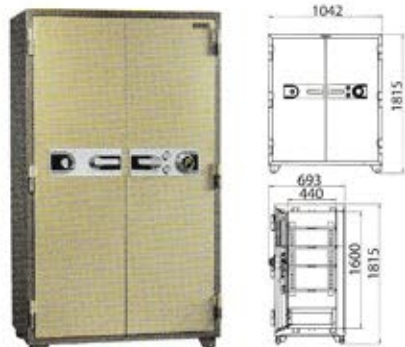
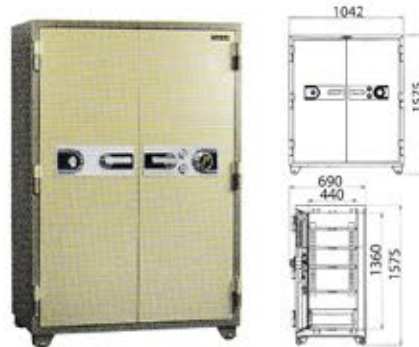
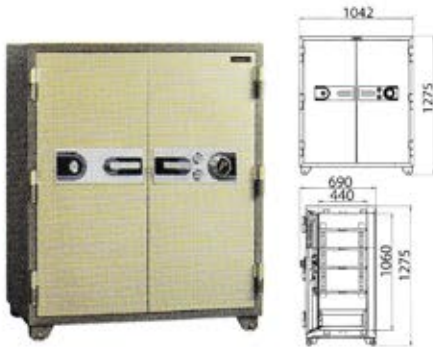

STD120

OUTSIZE W1042xD690xH1275
INSIDE W900xD440xH1060
CAPACITY 420 LITRES
NET WEIGHT 410 KG
ACCESSORY 4 SHELVES
FIRE RATEING 2 HR

STD150

OUTSIZE W1042xD690xH1575
INSIDE W900xD440xH1360
CAPACITY 538 LITRES
NET WEIGHT 550 KG
ACCESSORY 4 SHELVES
FIRE RATEING 2 HR

STD180

OUTSIZE W1042xD690xH1815
INSIDE W900xD440xH1600
CAPACITY 633 LITRES
NET WEIGHT 640 KG
ACCESSORY 4 SHELVES
FIRE RATEING 2 HR

NIGHT DEPOSITE SAFE

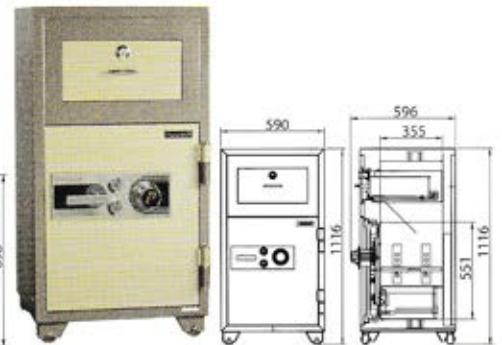
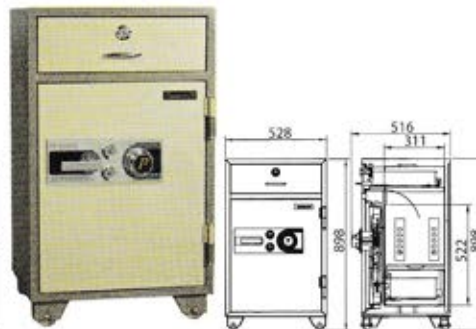
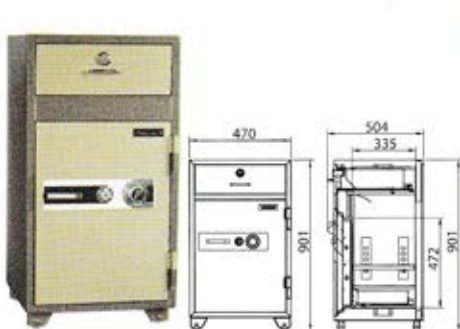

ND100

OUTSIZE W470xD504xH901
INSIDE W332xD335xH472
CAPACITY 52 LITRES
NET WEIGHT 130 KG
ACCESSORY 1 SHELF
FIRE RATEING 2 HR

ND150

OUTSIZE W528xD516xH898
INSIDE W409xD331xH522
CAPACITY 91 LITRES
NET WEIGHT 165 KG
ACCESSORY 1 SHELF
FIRE RATEING 2 HR

ND200

OUTSIZE W590xD596xH1116
INSIDE W450xD355xH551
CAPACITY 100 LITRES
NET WEIGHT 250 KG
ACCESSORY 1 SHELF
FIRE RATEING 2 HR



Big Size Dual Key



1Key 1Combination Lock



2Key 1Combination Lock



Small Size Dual Key



DIGITAL SLIDE

หน่วย : มม.

SMALL SAFE

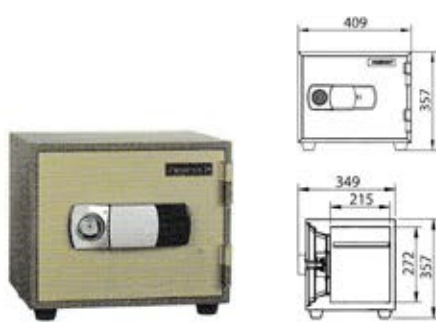

LS1D

OUTSIDE W409xD349xH357
 INSIDE W352xD215xH272
 CAPACITY 20 LITRES
 NET WEIGHT 28 KG
 ACCESSORY 1 TRAY
 FIRE RATEING 1 HR

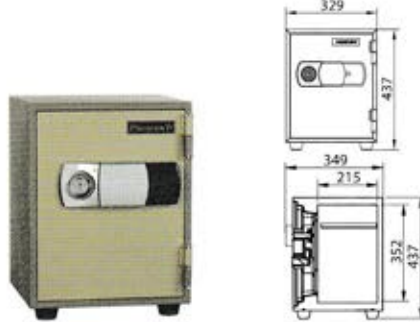

LS2D

OUTSIDE W329xD349xH437
 INSIDE W272xD215xH352
 CAPACITY 20 LITRES
 NET WEIGHT 28 KG
 ACCESSORY 1 TRAY
 FIRE RATEING 1 HR

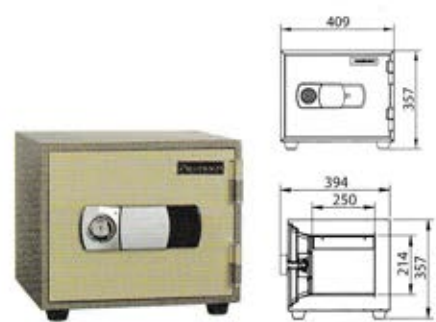

MS1D

OUTSIDE W409xD394xH357
 INSIDE W294xD250xH215
 CAPACITY 16 LITRES
 NET WEIGHT 40 KG
 ACCESSORY 1 TRAY
 FIRE RATEING 1 HR

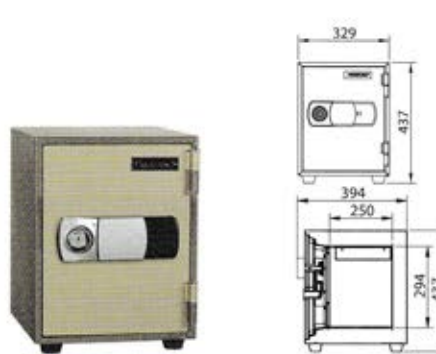

MS2D

OUTSIDE W329xD394xH437
 INSIDE W214xD250xH294
 CAPACITY 16 LITRES
 NET WEIGHT 40 KG
 ACCESSORY 1 TRAY
 FIRE RATEING 1 HR

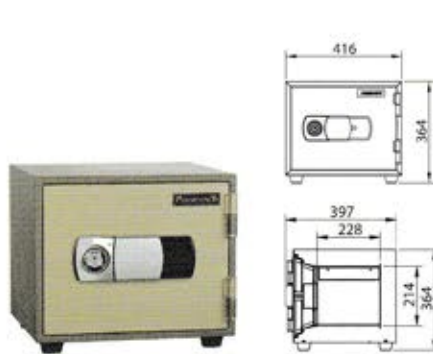

SS42LD

OUTSIDE W416xD397xH364
 INSIDE W294xD228xH214
 CAPACITY 20 LITRES
 NET WEIGHT 42 KG
 ACCESSORY 1 TRAY
 FIRE RATEING 1 HR

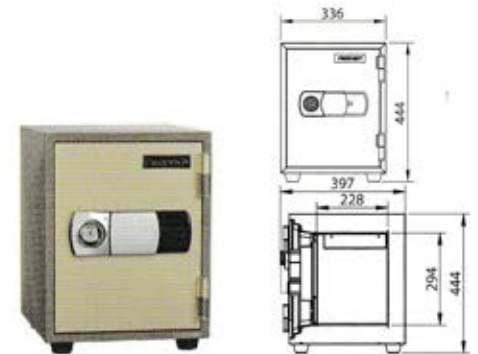

SS42VD

OUTSIDE W336xD397xH444
 INSIDE W214xD228xH294
 CAPACITY 20 LITRES
 NET WEIGHT 42 KG
 ACCESSORY 1 TRAY
 FIRE RATEING 1 HR

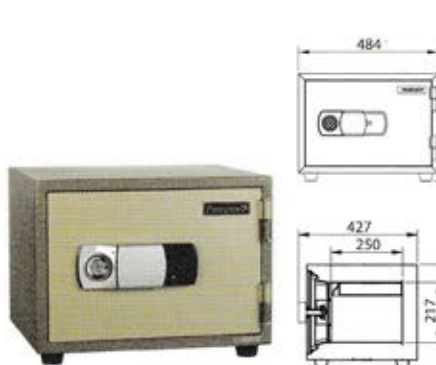

SS1D

OUTSIDE W484xD427xH372
 INSIDE W357xD264xH217
 CAPACITY 20 LITRES
 NET WEIGHT 50 KG
 ACCESSORY 1 TRAY
 FIRE RATEING 1 HR

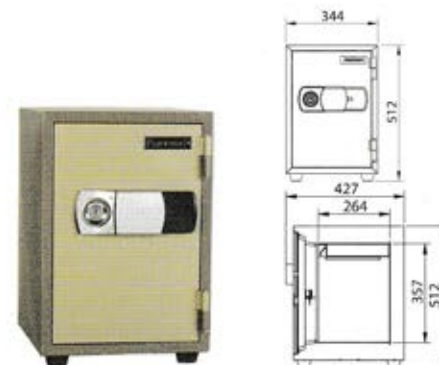

SS2D

OUTSIDE W344xD427xH512
 INSIDE W217xD264xH357
 CAPACITY 20 LITRES
 NET WEIGHT 50 KG
 ACCESSORY 1 TRAY
 FIRE RATEING 1 HR



DIGITAL SLIDE

หน่วย : มม.

MEDIUM SAFE

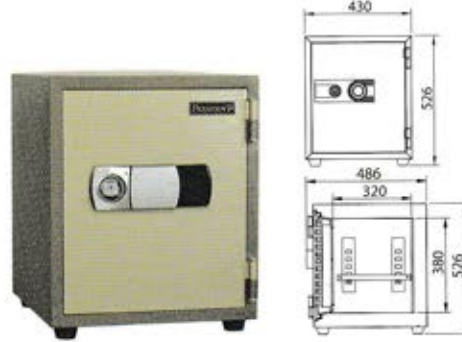
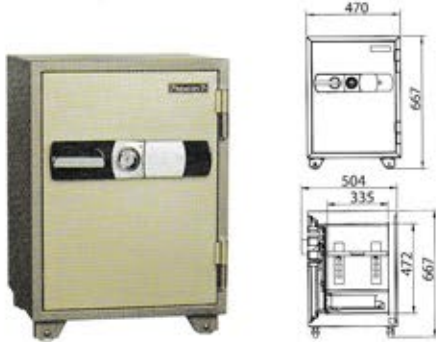

SMD

OUTSIZE W470xD504xH667
 INSIDE W332xD335xH472
 CAPACITY 52 LITRES
 NET WEIGHT 105 KG
 ACCESSORY 1 SHELF
 FIRE RATEING 2 HR

SS70D

OUTSIZE W430xD485xH526
 INSIDE W312xD320xH380
 CAPACITY 38 LITRES
 NET WEIGHT 70 KG
 ACCESSORY 1 SHELF
 FIRE RATEING 1 HR

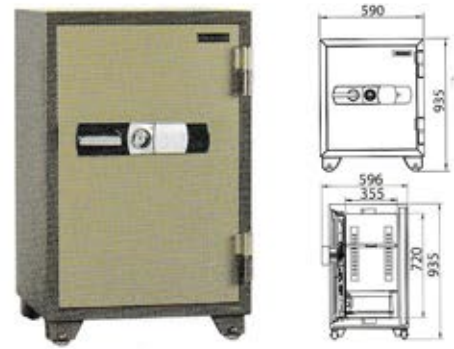
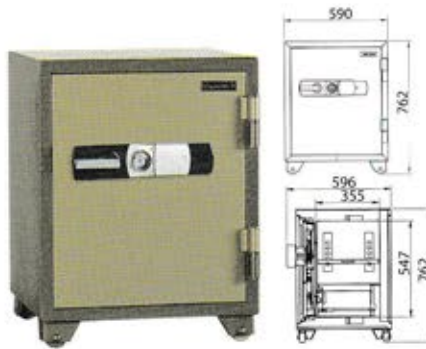
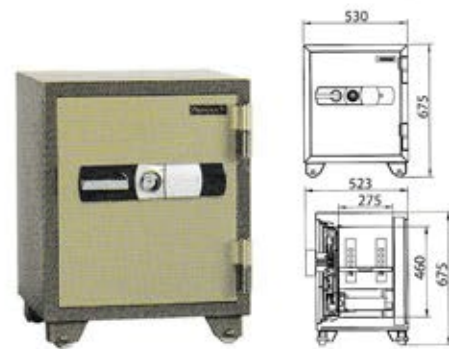

SB20D

OUTSIZE W530xD523xH675
 INSIDE W392xD275xH460
 CAPACITY 50 LITRES
 NET WEIGHT 110 KG
 ACCESSORY 1 SHELF
 FIRE RATEING 2 HR

SB30D

OUTSIZE W590xD596xH762
 INSIDE W450xD355xH547
 CAPACITY 87 LITRES
 NET WEIGHT 155 KG
 ACCESSORY 1 SHELF
 FIRE RATEING 2 HR

SB40D

OUTSIZE W590xD596xH935
 INSIDE W450xD355xH720
 CAPACITY 115 LITRES
 NET WEIGHT 190 KG
 ACCESSORY 1 SHELF
 FIRE RATEING 2 HR

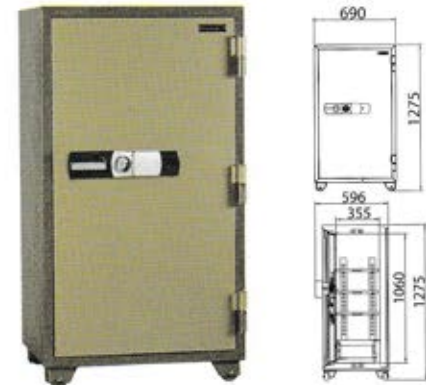
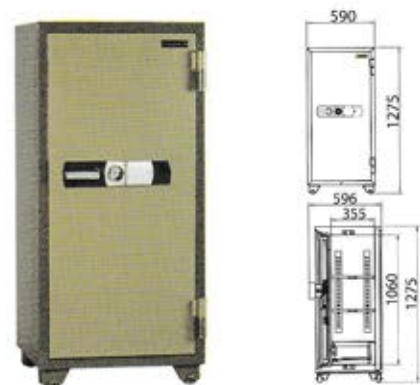

SB50D

OUTSIZE W590xD596xH1275
 INSIDE W450xD355xH1060
 CAPACITY 169 LITRES
 NET WEIGHT 250 KG
 ACCESSORY 2 SHELVES
 FIRE RATEING 2 HR

SB60D

OUTSIZE W690xD596xH1275
 INSIDE W550xD355xH1060
 CAPACITY 207 LITRES
 NET WEIGHT 295 KG
 ACCESSORY 3 SHELVES
 FIRE RATEING 2 HR

BIG SAFE

DIGITAL SLIDE

หน่วย : มม.

LARGE SAFE

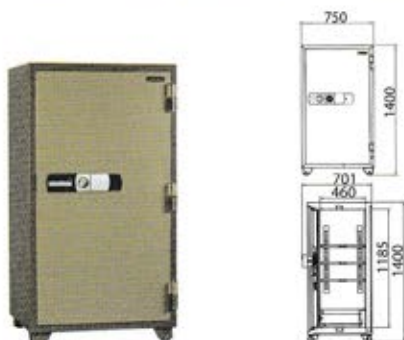

SB70D

OUTSIZE W750xD701xH1400
 INSIDE W610xD460xH1185
 CAPACITY 332 LITRES
 NET WEIGHT 370 KG
 ACCESSORY 3 SHELVES
 FIRE RATEING 2 HR

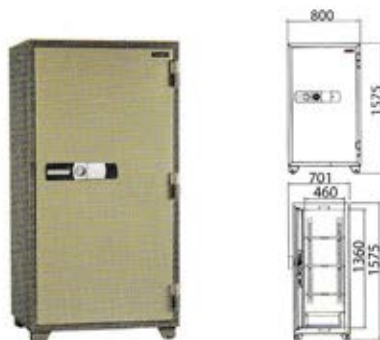

SB80D

OUTSIZE W800xD701xH1575
 INSIDE W660xD460xH1360
 CAPACITY 413 LITRES
 NET WEIGHT 460 KG
 ACCESSORY 3 SHELVES
 FIRE RATEING 2 HR

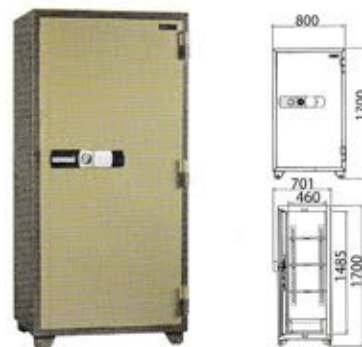

SB90D

OUTSIZE W800xD701xH1700
 INSIDE W660xD460xH1485
 CAPACITY 451 LITRES
 NET WEIGHT 495 KG
 ACCESSORY 3 SHELVES
 FIRE RATEING 2 HR

TWO DOOR SAFE

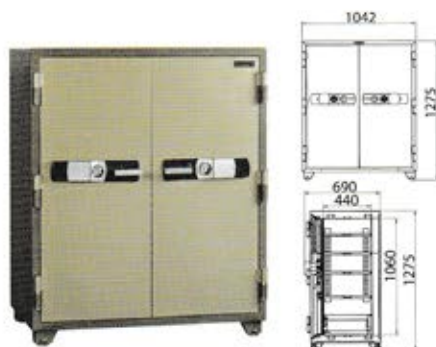

STD120D

OUTSIZE W1042xD690xH1275
 INSIDE W900xD440xH1068
 CAPACITY 420 LITRES
 NET WEIGHT 410 KG
 ACCESSORY 4 SHELVES
 FIRE RATEING 2 HR

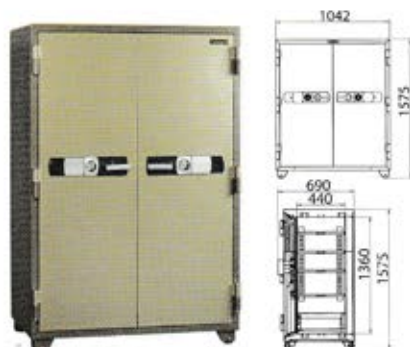

STD150D

OUTSIZE W1042xD690xH1575
 INSIDE W900xD440xH1360
 CAPACITY 538 LITRES
 NET WEIGHT 550 KG
 ACCESSORY 4 SHELVES
 FIRE RATEING 2 HR

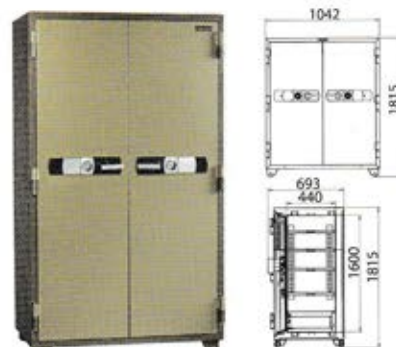

STD180D

OUTSIZE W1042xD690xH1815
 INSIDE W900xD440xH1600
 CAPACITY 633 LITRES
 NET WEIGHT 640 KG
 ACCESSORY 4 SHELVES
 FIRE RATEING 2 HR

NIGHT DEPOSITE SAFE

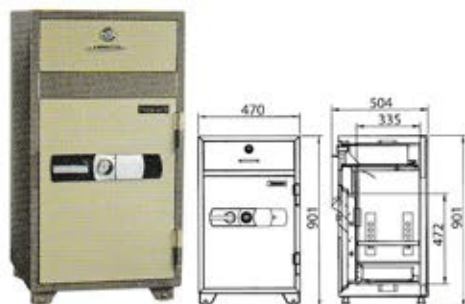

ND100D

OUTSIZE W470xD504xH901
 INSIDE W332xD335xH472
 CAPACITY 52 LITRES
 NET WEIGHT 130 KG
 ACCESSORY 1 SHELF
 FIRE RATEING 2 HR

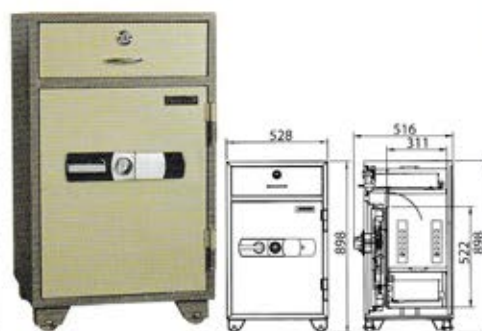

ND150D

OUTSIZE W528xD516xH898
 INSIDE W409xD331xH522
 CAPACITY 91 LITRES
 NET WEIGHT 165 KG
 ACCESSORY 1 SHELF
 FIRE RATEING 2 HR

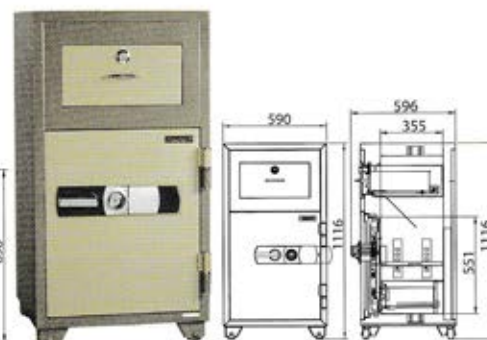

ND200D

OUTSIZE W590xD596xH1116
 INSIDE W450xD355xH551
 CAPACITY 100 LITRES
 NET WEIGHT 250 KG
 ACCESSORY 1 SHELF
 FIRE RATEING 2 HR



Small Size Digital Key

Big Size Digital Key

SAFE WITH TRAY

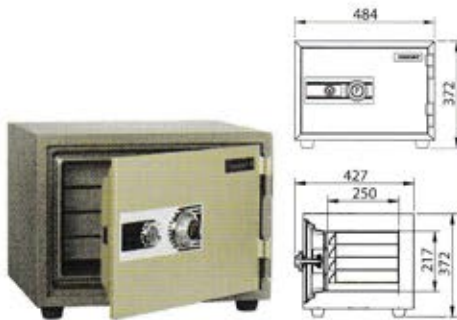

SS1T

OUTSIZE W409xD350xH357
 INSIDE W357xD264xH217
 CAPACITY 20 LITRES
 NET WEIGHT 50 KG
 ACCESSORY 4 TRAY
 FIRE RATEING 1 HR

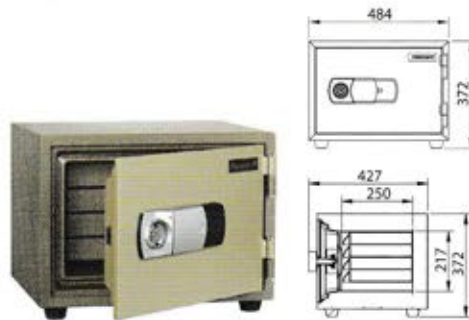

SS1TD

OUTSIZE W409xD349xH357
 INSIDE W352xD264xH217
 CAPACITY 20 LITRES
 NET WEIGHT 50 KG
 ACCESSORY 4 TRAY
 FIRE RATEING 1 HR



SS2T

OUTSIZE W344xD427xH512
 INSIDE W217xD264xH357
 CAPACITY 20 LITRES
 NET WEIGHT 50 KG
 ACCESSORY 7 TRAY
 FIRE RATEING 1 HR

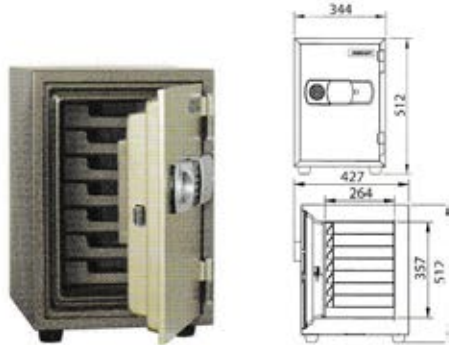
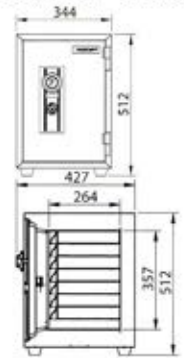

SS2TD

OUTSIZE W344xD427xH512
 INSIDE W217xD264xH357
 CAPACITY 20 LITRES
 NET WEIGHT 50 KG
 ACCESSORY 7 TRAY
 FIRE RATEING 1 HR

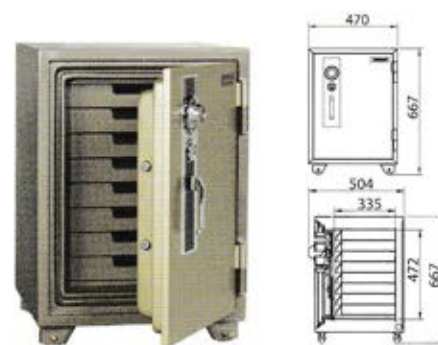

SMT

OUTSIZE W470xD504xH667
 INSIDE W332xD335xH472
 CAPACITY 52 LITRES
 NET WEIGHT 105 KG
 ACCESSORY 8 TRAY
 FIRE RATEING 2 HR

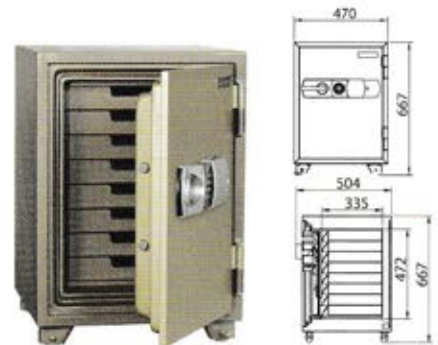

SMTD

OUTSIZE W470xD504xH667
 INSIDE W332xD335xH472
 CAPACITY 52 LITRES
 NET WEIGHT 105 KG
 ACCESSORY 8 TRAY
 FIRE RATEING 2 HR

2,3,4 DRAWERS FILLING SAFE

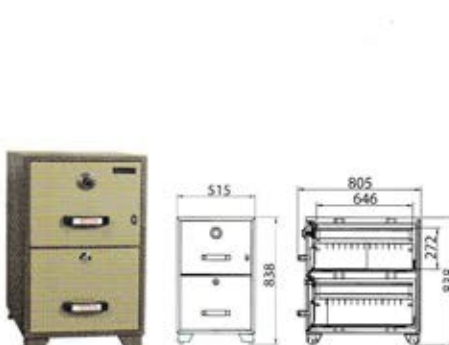

FRC220

OUTSIZE W515xD805xH838
 INSIDE W389xD646xH272x2
 CAPACITY 99 LITRES
 NET WEIGHT 145 KG
 FIRE RATEING 1 HR



FRC330

OUTSIZE W515xD805xH1200
 INSIDE W389xD646xH272x3
 CAPACITY 145 LITRES
 NET WEIGHT 236 KG
 FIRE RATEING 1 HR

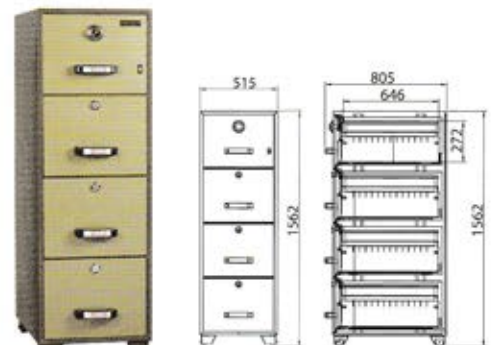

FRC440

OUTSIZE W515xD805xH1562
 INSIDE W389xD646xH272x4
 CAPACITY 198 LITRES
 NET WEIGHT 330 KG
 FIRE RATEING 1 HR

SAFE WITHOUT KEY

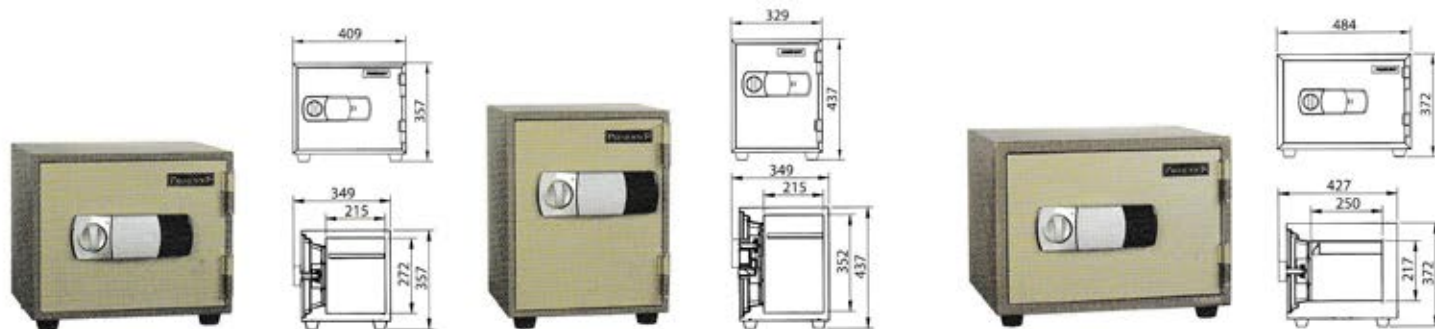
**LS1KN**

OUTSIZE	W409xD349xH357
INSIDE	W352xD215xH272
CAPACITY	20 LITRES
NET WEIGHT	28 KG
ACCESSORY	1 TRAY
FIRE RATEING	1 HR

LS2KN

OUTSIZE	W329xD349xH437
INSIDE	W272xD215xH352
CAPACITY	20 LITRES
NET WEIGHT	28 KG
ACCESSORY	1 TRAY
FIRE RATEING	1 HR

SS1KN

OUTSIZE	W484xD427xH372
INSIDE	W357xD264xH217
CAPACITY	20 LITRES
NET WEIGHT	50 KG
ACCESSORY	1 TRAY
FIRE RATEING	1 HR

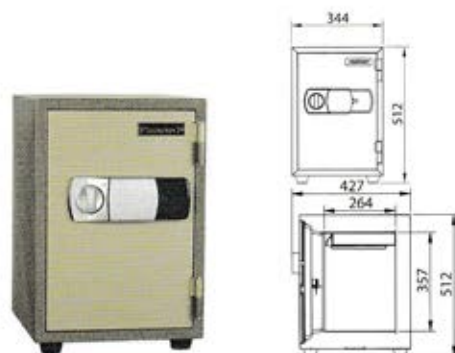
**SS2KN**

OUTSIZE	W344xD427xH512
INSIDE	W217xD264xH357
CAPACITY	20 LITRES
NET WEIGHT	50 KG
ACCESSORY	1 TRAY
FIRE RATEING	1 HR

HOTEL SAFE

FIRE SAFE

**HSP23**

OUTSIZE	W444xD407xH249
INSIDE	W329xD224xH144
CAPACITY	10.6 LITRES
NET WEIGHT	30 KG
ACCESSORY	1 PLASTIC TRAY
FIRE RATEING	1 HR

HSP101

OUTSIZE	W412xD355xH325
INSIDE	W334xD232xH227.5
CAPACITY	17.63 LITRES
NET WEIGHT	34 KG
ACCESSORY	1 PLASTIC TRAY
FIRE RATEING	1 HR

NON-FIRE SAFE

**HSP210**

OUTSIZE	W440xD310xH210
INSIDE	W436xD231xH206
CAPACITY	20.75 LITRES
NET WEIGHT	10 KG
FIRE RATEING	NON

HSP230

OUTSIZE	W380xD310xH230
INSIDE	W376xD231xH226
CAPACITY	14.41 LITRES
NET WEIGHT	11 KG
FIRE RATEING	NON



DIGITAL D2

หน่วย : มม.

SMALL SAFE

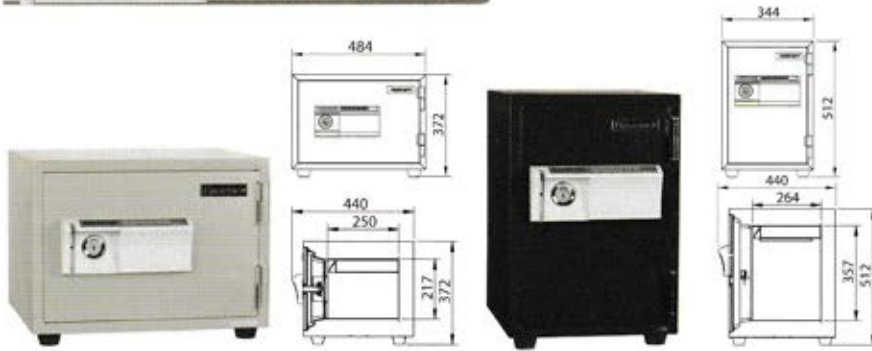

SS1D2

OUTSIZE W484xD440xH372
 INSIDE W357xD264xH217
 CAPACITY 20 LITRES
 NET WEIGHT 50 KG
 ACCESSORY 1 TRAY
 FIRE RATEING 1 HR

SS2D2

OUTSIZE W344xD440xH512
 INSIDE W127xD264xH357
 CAPACITY 20 LITRES
 NET WEIGHT 50 KG
 ACCESSORY 1 TRAY
 FIRE RATEING 1 HR

MEDIUM SAFE

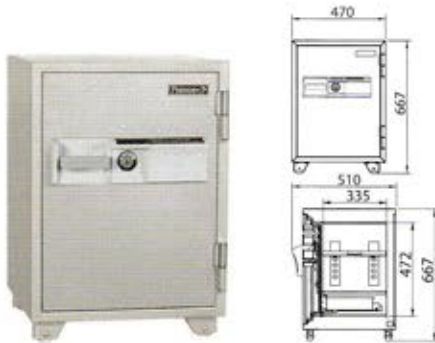

SMD2

OUTSIZE W470xD510xH667
 INSIDE W332xD335xH472
 CAPACITY 52 LITRES
 NET WEIGHT 105 KG
 ACCESSORY 1 SHELF
 FIRE RATEING 2 HR

BIG SAFE

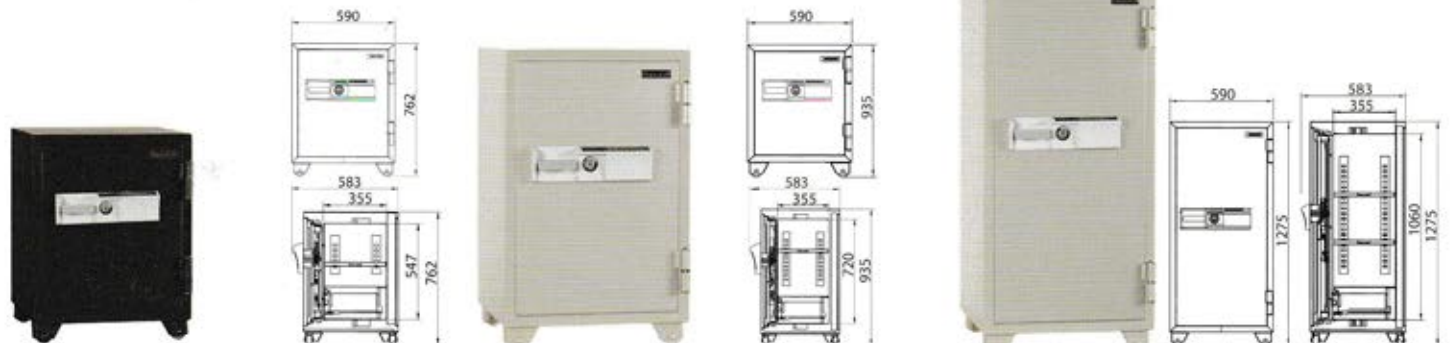

SB30D2

OUTSIZE W590xD583xH762
 INSIDE W450xD355xH547
 CAPACITY 87 LITRES
 NET WEIGHT 155 KG
 ACCESSORY 1 SHELF
 FIRE RATEING 2 HR

SB40D2

OUTSIZE W590xD583xH935
 INSIDE W450xD355xH720
 CAPACITY 115 LITRES
 NET WEIGHT 190 KG
 ACCESSORY 1 SHELF
 FIRE RATEING 2 HR

SB50D2

OUTSIZE W590xD583xH1275
 INSIDE W450xD355xH1060
 CAPACITY 169 LITRES
 NET WEIGHT 250 KG
 ACCESSORY 2 SHELF
 FIRE RATEING 2 HR



Small Size New Digital Lock



Big Size New Digital Lock



ONLY



BK



DI

THE SUPERIOR FIRE RESISTANT SAFE



เหตุการณ์เพลิงไหม้ห้างสรรพสินค้าซูเปอร์ซีป จ.ภูเก็ต เมื่อวันที่ 16 ตุลาคม 2556



สภาพสิ่งของภายในตู้เซฟเพชรซิเด็นท์ยังคงเดิม 100% แม้ว่าจะมีถุงและกล่องพลาสติกอยู่

BODY FINISH COLOR



MG



GT5



GO



BK



NN



DI



บริษัท เพรสซิเด็นท์ ออฟฟิศ เฟอร์นิเจอร์ จำกัด

77 หมู่ 5 ถ.เลียบคลองหมื่นปรารมย์ ต.ไคราย อ.กระทุ่มแบน จ.สมุทรสาคร 74110
โทร : 034-476075 มือถือ : 092-4969961, 092-4969962 แฟกซ์ : 034-476076

PRESIDENT OFFICE FURNITURE CO.,LTD.

77 M00 5, TANON LIABKLONGMUENPRAROM, KRATUMBAN, SAMUTSAKORN 74110, THAILAND.

TEL : (+6634) 476075 Mobile : (+6692) 4969961, (+6692) 4969962 FAX : (+6634) 476076

Visit us : www.presidentsafefur.com



THAILAND
TRUSTED QUALITY

Thailand Trust Mark by Department of International Trade Promotion, Ministry of Commerce



ISO 9001 QMS 03213/817
ISO 14001 EMS 13008/393



QMS 002/EMS 005

Quality and Environmental Management System

by Management System Certification Institute (Thailand)



กระทรวงอุตสาหกรรม

"อุตสาหกรรมสีเขียว"

Green Industrial Certification by Ministry of Industry



CSR-DIW Continuous Award Corporate Social Responsibility-Department of Industrial Work

โครงการพัฒนาความรับผิดชอบต่อสังคมอย่างมีส่วนร่วมโดยกรมโรงงานอุตสาหกรรม กระทรวงอุตสาหกรรม



มอก. 437-2529

Thai Industrial Standard มาตรฐานอุตสาหกรรมไทย



JIS S 1037 : 2013

Japan Industrial Standard มาตรฐานอุตสาหกรรมญี่ปุ่น



JAPAN TESTING CENTER FOR CONSTRUCTION MATERIALS