



TECHNICAL DATA

GENERAL		D151AEG
Unloading system	-	Rotating
Load capacity	Kg	1500
Chassis	-	Articulated
Water hopper capacity	l	520
Level hopper capacity	l	626
Heaped hopper capacity	l	900
Empty weight *	Kg	1565
Transmission	-	Electric
ENGINE		
Peak/Nominal power	kW	17,3 / 7,6
Torque	N-m@rpm	105@2770
Peak torque	N.m	130
Emissions	-	Zero at the point of use
Nominal voltage	V	32 AC Triphasic
DRIVING		
Max. speed	Km/h	15
Maximum gradient	%	35
External turning radius	mm	3390
Traction	-	4x4
Tyres	-	10.0/75-15.3
HYDRAULIC SYSTEM		
Hydraulic circuit	-	12cc. Gear pump
Flow rate	l/min	18
Working pressure	bar	170
Tank capacity	l	24,5
BRAKES		
Service	-	Sealed. Hydraulic drive
Parking	-	Negative brake and electro-hydraulic release
CHARGE		
Built-in charger that allows it to be connected directly to an AC power source		
Approximate charging time, 20-80%	-	2h (@230V) **
With external fast charging, 20-80%	-	1h 24min (@415V) **
Charging cable plug type	-	16A 110V (yellow); 16A 230V (blue); 16A 415V (red)
BATTERY		
Battery type	-	Lithium Ion Battery (NCM)
Gross capacity	kWh	9,3/12,4
System voltage	V	48
Autonomy	-	One intense shift ***

* It may change due to optional equipment. ** Subject to environmental conditions and to the kind and power of charging station. *** Subject to environmental conditions and the kind of use. For temperatures under 0°C it is recommended to fit the Long Range pack.

DIMENSIONS

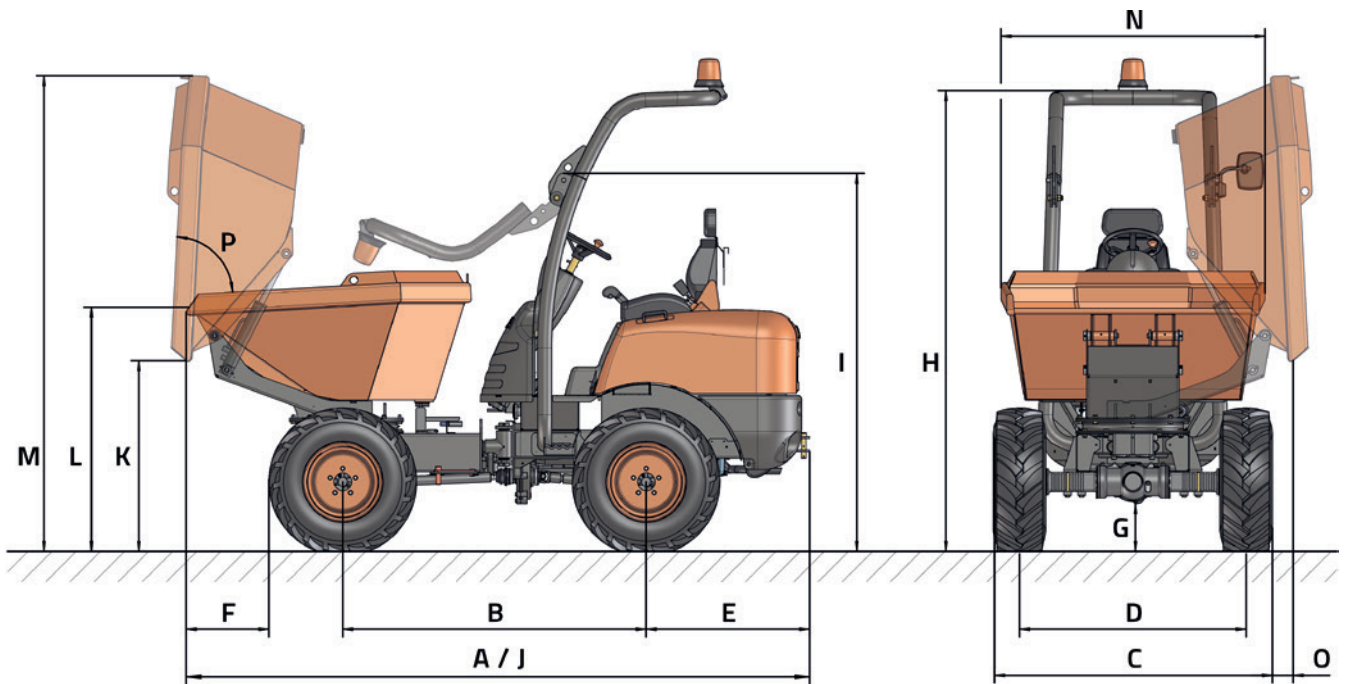

DIMENSIONS (mm)	D151AEG
A	3360
B	1650
C	1480
D	1195
E	885
F	460
G	250
H	2600
I	1730
J	3235
K	1000
L	1290
M	2500
N	1400
O	135
DIMENSIONS (°)	
P	83



www.ausa.com

Products are subject to modifications without prior notice. Images throughout the spec sheet may refer to non-standard machines or non-available configurations depending on models.

AUSA's logo and corporate identity are property of the Company, they cannot be used without authorization.