

# Ravi Maths Tuition

## Light Reflection and Refraction

### 10th Standard

### Science

#### Multiple Choice Question

72 x 1 = 72

- 1) Which one of the following materials cannot be used to make a lens?  
(a) Water (b) Glass (c) Plastic (d) Clay
- 2) The image formed by a concave mirror is observed to be virtual, erect and larger than the object. Where should be the position of the object?  
(a) Between the principal focus and the centre of curvature (b) At the centre of curvature  
(c) Beyond the centre of curvature (d) Between the pole of the mirror and its principal focus.
- 3) Where should an object be placed in front of a convex lens to get a real image of the size of the object?  
(a) At the principal focus of the lens (b) At twice the focal length (c) At infinity  
(d) Between the optical centre of the lens and its principal focus
- 4) A spherical mirror and a thin spherical lens have each a focal length of - 15 cm. The mirror and the lens are likely to be  
(a) both concave (b) both convex (c) the mirror is concave and the lens is convex.  
(d) the mirror is convex, but the lens is concave.
- 5) No matter how far you stand from a mirror, your image appears erect. The mirror is likely to be  
(a) plane (b) concave (c) convex (d) either plane or convex
- 6) Which of the following lenses would you prefer to use while reading small letters found in a dictionary?  
(a) A convex lens of focal length 50 cm (b) A concave lens of focal length 50 cm  
(c) A convex lens of focal length 5 cm (d) A concave lens of focal length 5 cm
- 7) Which of the following can make a parallel beam of light when light from a point source is incident on it?  
(a) Concave mirror as well as convex lens (b) Convex mirror as well as concave lens  
(c) Two plane mirrors placed at  $90^\circ$  to each other (d) Concave mirror as well as concave lens
- 8) A 10 mm long awl pin is placed vertically in front of a concave mirror. A 5 mm long image of the awl pin is formed at 30 cm in front of the mirror. The focal length of this mirror is.  
(a) - 30 cm (b) - 20 cm (c) - 40 cm (d) - 60 cm
- 9) Under which of the following conditions a concave mirror can form an image larger than the actual object?  
(a) When the object is kept at a distance equal to its radius of curvature  
(b) When object is kept at a distance less than its focal length  
(c) When object is placed between the focus and centre of curvature  
(d) When object is kept at a distance greater than its radius of curvature
- 10) Which of the following statements is true?  
(a) A convex lens has 4 dioptre power having a focal length 0.25 m  
(b) A convex lens has -4 dioptre power having a focal length 0.25 m  
(c) A concave lens has 4 dioptre power having a focal length 0.25 m  
(d) A concave lens has -4 dioptre power having a focal length 0.25 m.

- 11) Magnification produced by a rear view mirror fitted in vehicles  
 (a) is less than one (b) is more than one (c) is equal to one  
 (d) can be more than or less than one depending upon the position of the object in front of it.
- 12) Rays from Sun converge at a point 15 cm in front of a concave mirror. Where an object should be placed so that size of its image is equal to the size of the object?  
 (a) 30 cm in front of the mirror (b) 15 cm in front of the mirror  
 (c) between 15 cm and 30 cm in front of the mirror (d) more than 30 cm in front of the mirror.
- 13) A full length image of a distant tall building can definitely be seen by using.  
 (a) a concave mirror (b) a convex mirror (c) a plane mirror  
 (d) both concave as well as plane mirror
- 14) In torches search lights and headlights of vehicles the bulb is placed  
 (a) between the pole and the focus of the reflector (b) very near to the focus of the reflector  
 (c) between the focus and centre of curvature of the reflector  
 (d) at the centre of curvature of the reflector.
- 15) The laws of reflection hold good for  
 (a) plane mirror only (b) concave mirror only (c) convex mirror only  
 (d) all mirrors irrespective of their shape
- 16) You are given water, mustard oil, glycerine and kerosene. In which of these media a ray light incident obliquely at same angle would bend the most?  
 (a) Kerosene (b) Water (c) Mustard oil (d) Glycerine
- 17) A child is standing in front of a magic mirror. She finds the image of her head bigger, the middle portion of her body of the same size and that of the legs smaller. The following is the order of combinations for the magic mirror from the top.  
 (a) Plane, convex and concave (b) Convex, concave and plane (c) Concave, plane and concave  
 (d) Convex, plane and concave
- 18) In which of the following, the image of an object placed at infinity will be highly diminished and point sized?  
 (a) Concave mirror only (b) Convex mirror only (c) Convex lens only  
 (d) Concave mirror, convex mirror, concave lens and convex lens
- 19) The following Figure shows a ray of light as it travels from medium A to medium B. Refractive index of the medium B relative to medium A is

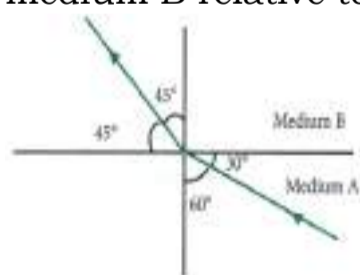

- (a)  $\frac{\sqrt{3}}{\sqrt{2}}$  (b)  $\frac{\sqrt{2}}{\sqrt{3}}$  (c)  $\frac{1}{\sqrt{2}}$  (d)  $\sqrt{2}$
- 20) A light ray enters from medium A to medium B as shown in Figure. The refractive index of medium B relative to A will be

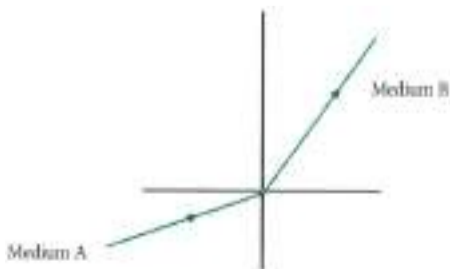

- (a) greater than unity (b) less than unity (c) equal to unity (d) zero

- 21) Beams of light are incident through the holes A and B and emerge out of box through the holes C and D respectively as shown in the Figure. Which of the following could be inside the box?

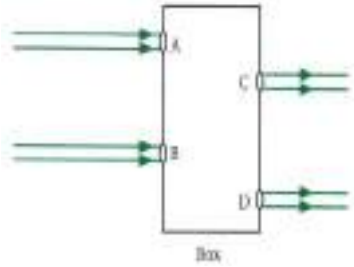

- (a) A rectangular glass slab (b) A convex lens (c) A concave lens (d) A prism

- 22) A beam of light is incident through the holes on side A and emerges out of the holes on the other face of the box as shown in the figure. Which of the following could be inside the box?

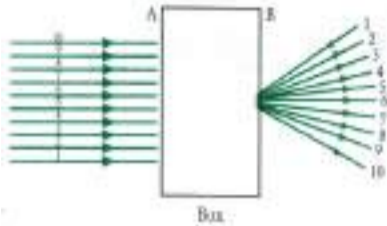

- (a) Concave lens (b) Rectangular glass slab (c) Prism (d) Convex lens

- 23) The path of a ray of light coming from air passing through a rectangular glass slab traced by four students are shown as A, B, C and D in Figure. Which one of them is correct?

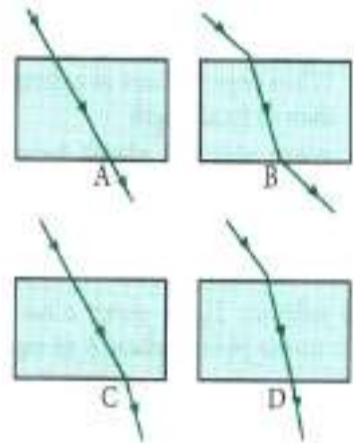

- (a) A (b) B (c) C (d) D

- 24) Which of the following ray diagrams is correct for the ray of light incident on a concave mirror as shown in Figure?

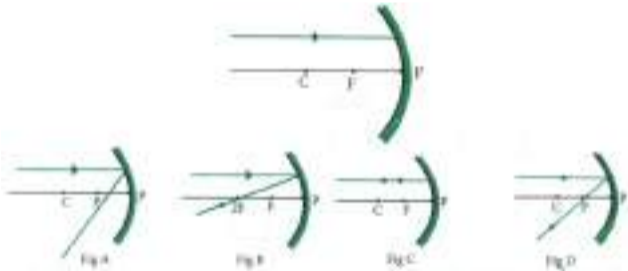

- (a) Fig. A (b) Fig. B (c) Fig. C (d) Fig. D

- 25) Which of the following ray diagram is correct for the ray of light incident on a lens shown in Figure?

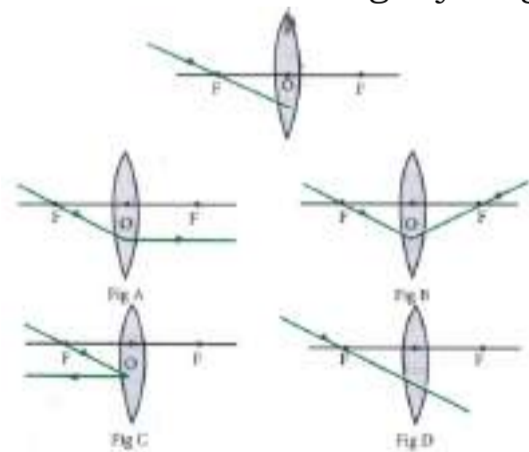

- (a) Fig. A (b) Fig. B (c) Fig. C (d) Fig. D

- 26) Focal length of plane mirror is

- (a) at infinity (b) zero (c) negative (d) none of these

- 27) Image formed by plane mirror is

- (a) real and erect (b) real and inverted (c) virtual and erect (d) virtual and inverted

- 28) A concave mirror gives, real, inverted and same size image if the object is placed  
 (a) at F (b) at infinity (c) at C (d) beyond C
- 29) Power of a lens is - 4, its focal length is  
 (a) 4 m (b) - 40 cm (c) - 0.25 m (d) - 25 m.
- 30) A concave mirror gives virtual, erect and enlarged image if the object is placed  
 (a) at infinity (b) between F and C (c) between P and F (d) at F
- 31) The mirror that always gives virtual and erect image of the object but image of smaller size than the size of the object is  
 (a) Plane mirror (b) Concave mirror (c) Convex mirror (d) none of these
- 32) All the distances in case of spherical mirror are measured in relation  
 (a) object to image (b) the pole of the mirror (c) the focus of the mirror (d) the image to the object.
- 33) The radius of curvature and focal length of a concave mirror are  
 (a) positive (b) negative (c) both (d) none of these
- 34) The object distance in both concave as well as convex mirror is  
 (a) negative (b) positive (c) zero (d) none of these
- 35) The ratio of the speed of light in vacuum to that in a medium is known as  
 (a) magnification (b) refraction (c) refractive index (d) Snell's law
- 36) In optics an object which has higher refractive index is called  
 (a) optically rarer (b) optically denser (c) optical density (d) refractive index
- 37) The optical phenomena, twinkling of stars, is due to  
 (a) atmospheric reflection (b) total reflection (c) atmospheric refraction (d) total refraction
- 38) Convex lens forms a real, point sized image at focus, the object is placed  
 (a) at focus (b) between F and 2F (c) at infinity (d) at 2F
- 39) The unit of power of lens is  
 (a) metre (b) centimetre (c) dioptre (d) m-I
- 40) The radius of curvature of a mirror is 20 cm the focal length is  
 (a) 20 cm (b) 10 cm (c) 40 cm (d) 5 cm
- 41) The refractive indices of some media are given below

Medium	Refractive index
X	1.51
y	1.72
Z	1.83
W	2.42

- In which of these is the speed of light minimum and maximum, respectively  
 (a) X-minimum, W-maximum (b) Z-minimum, W-maximum (c) W-minimum, X-maximum  
 (d) X-minimum, Z-maximum
- 42) The power of a lens is + 1.6 D. The nature of lens is  
 (a) Convex lens (b) Concave lens (c) both concave and convex (d) none of these
- 43) An incident ray makes  $60^\circ$  angle with the surface of the plane mirror, the angle of its reflection is  
 (a)  $60^\circ$  (b)  $90^\circ$  (c)  $30^\circ$  (d)  $0^\circ$

- 44) The angle of reflection in the given figure is

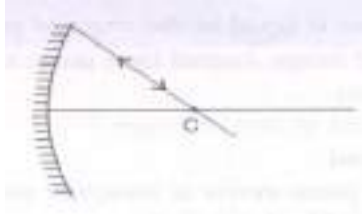

- (a)  $90^\circ$  (b)  $180^\circ$  (c)  $0^\circ$  (d)  $30^\circ$
- 45) A mirror that has very wide field view is  
(a) concave (b) convex (c) plane (d) none of these
- 46) If the object is placed at focus of a concave mirror, the image is formed at  
(a) infinity (b) focus (c) centre of curvature (d) between F and P.
- 47)

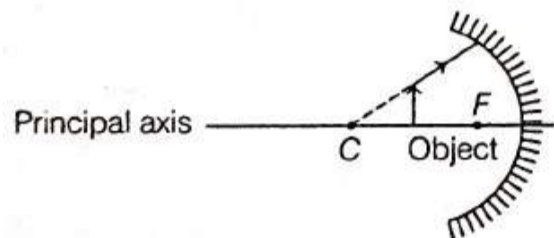

While looking at the above diagram, Nalini concluded the following?

- I. The image of the object will be a virtual one.  
II. The reflected ray will travel along the same path as the incident ray but in opposite direction.  
III. The image of the object will be inverted.  
IV. This is a concave mirror and hence the focal length will be negative.

Which of the above statements are correct?

- (a) I and II (b) I and III (c) II, III and IV (d) I, II, III and IV
- 48) To obtain a magnification of +2 with a concave mirror of radius of curvature 60 cm the object distance must be  
(a) -90 cm (b) -45 cm (c) -30 cm (d) -15 cm
- 49) The image of a candle flame formed by a mirror is obtained on a screen placed on the same side of the mirror. According to new cartesian sign convention, If the image is three times the size of the flame, then the mirror is \_\_\_\_\_  
(a) concave and magnification is +3 (b) concave and magnification is -3  
(c) convex and magnification is -3 (d) convex and magnification is +3
- 50) The image of an object placed in front of a concave mirror of focal length 15 cm is of the same size as the object. The distance between the object and its image is  
(a) 15 cm (b) 30 cm (c) 60 cm (d) zero
- 51) Which of the following mirror is used by a dentist to examine a small cavity In a patient's teeth?  
(a) Convex mirror (b) Plane mirror (c) Concave mirror (d) Any spherical mirror
- 52) Consider those Indices of refraction : glass: 1.52; air: 1.0003 ; water : 1.333. Based on the refractive indices of three materials, arrange the speed of light through them in decreasing order.  
(a) The speed of light in water > the speed of light in air > the speed of light in glass  
(b) The speed of light glass > the speed of light in water > the speed of light in air  
(c) The speed of light in air > the speed of light in water > the speed of light in glass  
(d) The speed of light in glass > the speed of light in air > the speed of light in water
- 53) When an Incident ray of light enters a medium from air, It bends towards the normal. Which of the following is true about the refractive index of the medium ( $n_m$ ) as compared to the refractive index of air ( $n_a$ )?  
(a)  $n_m$  is equal to  $n_a$  (b)  $n_m$  is less than  $n_a$  (c)  $n_m$  is more than  $n_a$   
(d) The refractive indices cannot be compared based on the given information

54)

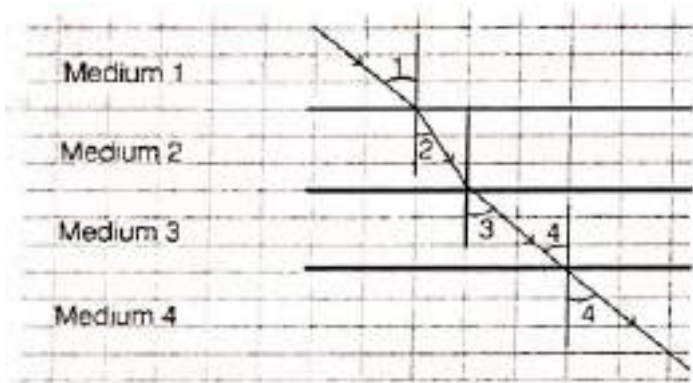

In the above diagram, light is travelling through different media. It is noted by a scientist that  $\angle 1 = \angle 3 = \angle 4$  but  $\angle 2 < \angle 1$ . Which of the following statement would be Correct?

- (a) Medium 1 is denser than medium 3 but its density is equal to medium 2.
  - (b) Medium 2 is the rarest medium. (c) Medium 3 is denser than medium 1.
  - (d) Medium 1 and 3 are essentially the same medium but medium 2 is denser than 1 and 3.
- 55) The refractive index of flint glass is 1.65 and that for alcohol is 1.36 with respect to air. What is the refractive index of the flint glass with respect to alcohol?
- (a) 0.82 (b) 1.21 (c) 1.11 (d) 1.01
- 56) The angle of Incidence from air to glass at the point O on the hemispherical glass slab is
- (a)  $45^\circ$  (b)  $0^\circ$  (c)  $90^\circ$  (d)  $180^\circ$
- 57) When light is incident on a glass slab, the incident ray, refracted ray and the emergent ray are in three media A, B and C. If  $n_1$ ,  $n_2$ , and  $n_3$ , are the refractive indices of A, B and C respectively and the emergent ray is parallel to the incident ray, which of the following is true?
- (a)  $n_1 < n_2 < n_3$  (b)  $n_1 > n_2 > n_3$  (c)  $n_1 < n_2 = n_3$  (d)  $n_1 = n_3 < n_2$
- 58) Study the diagram given below and identify the type of the lens  $XX'$  and the position of the point on the principal axis  $OO'$  where the image of the object AB appears to be formed

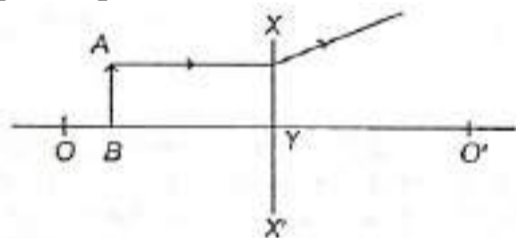

- (a) concave; between  $O'$  and Y (b) concave; between O and Y (c) convex; between  $O'$  and Y
  - (d) convex; between O and Y
- 59) An object of height 8 cm is placed at a distance of 40 cm in front of a convex lens of focal length 20 cm. The size of image is \_\_\_\_\_.
- (a) 12 cm (b) 4 cm (c) -8 cm (d) 16 cm
- 60) If a lens and a spherical mirror both have a focal length of -15 cm, then it may be concluded that
- (a) both are concave (b) the lens is concave and the mirror is convex
  - (c) the lens is convex and the mirror is concave (d) both are convex
- 61) If the real image of a candle flame formed by a lens is three times the size of the flame and the distance between lens and image is 80 cm, at what distance should the candle be placed from the lens?
- (a) - 80 cm (b) -40 cm (c)  $-\frac{40}{3}$  cm (d)  $-\frac{80}{3}$  cm

62) Which diagram shows image formation of an object on a screen by a converging lens?

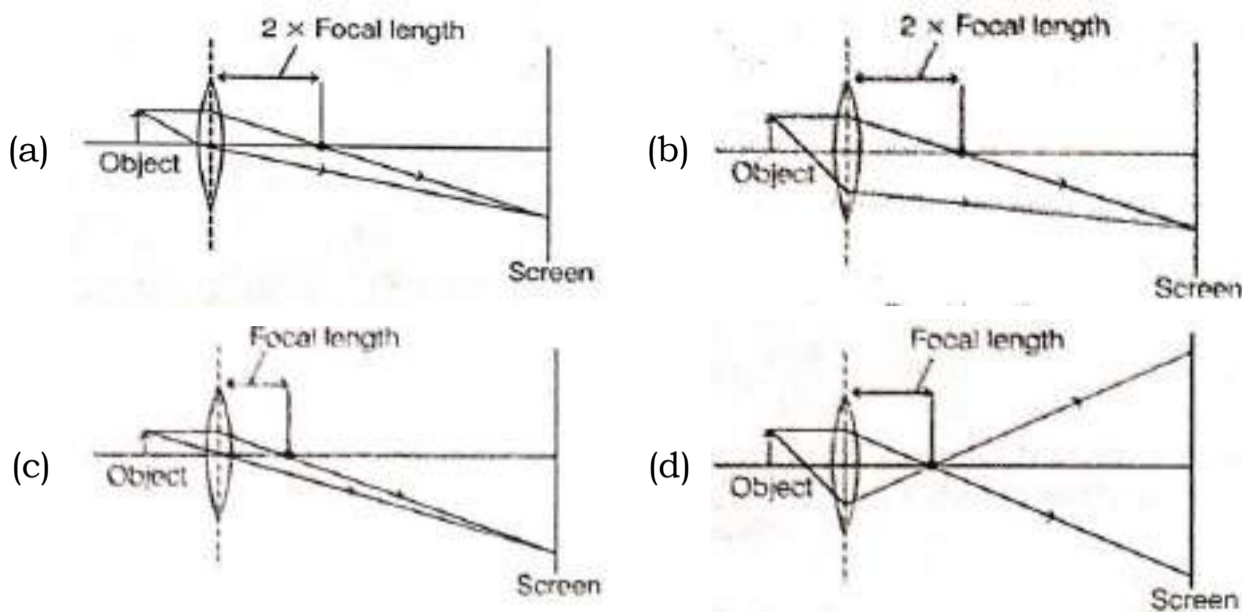

63) An object is placed in front of a concave lens. For all positions of the object, the image formed is always

- (a) real, diminished and inverted (b) virtual, diminished and erect (c) real, enlarged and erect  
(d) virtual, erect and enlarged

64) An object of height 3.0 cm is placed vertically on the principal axis of a convex lens. When the object distance is -37.5 cm, an image of height -2.0 cm is formed at a distance of 25.0 cm from the lens. Next, the same object is placed vertically at 25.0 cm from the lens. In this situation, the image distance  $v$  and height  $h$  of the image is (according to the new cartesian sign convention)

- (a)  $v = +37.5$  cm;  $h = +4.5$  cm (b)  $v = -37.5$  cm;  $h = +4.5$  cm (c)  $v = +37.5$  cm;  $h = -4.5$  cm  
(d)  $v = -37.5$  cm;  $h = -4.5$  cm

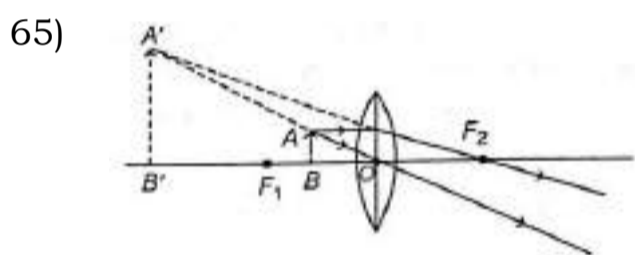

The above lens has a focal length of 10 cm. The object of height 2 mm is placed at a distance of 5 cm from the pole. Find the height of the image.

- (a) 4 cm (b) 6.67 mm (c) 4 mm (d) 3.33 mm

66) Two thin lenses of power 3D and -2D are placed in contact, then power and focal length of the lens combination is

- (a) +2D, +100 cm (b) +1D, +100 cm (c) +5D, +20 cm (d) +1D, -100 cm

67) If the power of a lens is -4.0 D, then it means that the lens is a

- (a) concave lens of focal length -50 m (b) convex lens of focal length +50 cm  
(c) concave lens of focal length -25 cm (d) convex lens of focal length -25 m

68) A lens has a power of +4.0 D. It is

- (a) a convex lens of focal length 4 m (b) a concave lens of focal length 4 m  
(c) a convex lens of focal length 0.25 m (d) a concave lens of focal length 0.25 m

69) Two convex lenses P and Q have focal length 0.50 m and 0.40 m respectively. Which of the following is true about the combined power of the two lenses?

- (a) P is equal to 4.5 D (b) P is less than 4.5 D (c) P is more than 4.5 D (d) P cannot be determined

70) To determine the focal length of a concave mirror by forming image of a distant object, the screen should be placed

- (a) in any direction (b) inclined at angle of  $45^\circ$  (c) at right angle to the plane of mirror  
(d) parallel to the plane of mirror

- 71) In order to determine focal length of a concave mirror by obtaining the image of distant object on screen, you need to measure the distance between  
 (a) mirror and the screen (b) object and screen (c) mirror and object  
 (d) mirror and screen also between object and screen
- 72) In an experiment to study independent inheritance of two separate traits : shape and colour of seeds, the ratio of the different combination in  $F_2$  progeny would be  
 (a) 1 : 3 (b) 1 : 2 : 1 (c) 9 : 3 : 3 : 1 (d) 9 : 1 : 1 : 3

Assertion and reason

20 x 1 = 20

- 73) **Assertion:** The sunlight that passes through the lens burns the paper at the spot.  
**Reason:** The heat produced due to the concentration of sunlight ignites the paper  
**Codes**  
 (a) If both assertion and reason are true and the reason is correct explanation of assertion.  
 (b) If both assertion and reason are true but reason is not a correct explanation of assertion. -.  
 (c) If assertion is true and reason is false.  
 (d) If both assertion and reason are false.
- 74) **Assertion:** The dentists use convex mirrors to see large images of the teeth of patients.  
**Reason:** The convex mirrors always produces the enlarged image of the object.  
**Codes**  
 (a) If both assertion and reason are true and the reason is correct explanation of assertion.  
 (b) If both assertion and reason are true but reason is not a correct explanation of assertion. -.  
 (c) If assertion is true and reason is false.  
 (d) If both assertion and reason are false.
- 75) **Assertion:** A convex lens of short focal length bends the light rays through large angles.  
**Reason:** This helps in by focusing the light closer to the optical centre.  
**Codes**  
 (a) If both assertion and reason are true and the reason is correct explanation of assertion.  
 (b) If both assertion and reason are true but reason is not a correct explanation of assertion. -.  
 (c) If assertion is true and reason is false.  
 (d) If both assertion and reason are false.
- 76) **Assertion:** Opticians prescribe corrective lenses indicating their powers  
**Reason:** The power of a convex lens is negative and that of a concave lens is positive.  
**Codes**  
 (a) If both assertion and reason are true and the reason is correct explanation of assertion.  
 (b) If both assertion and reason are true but reason is not a correct explanation of assertion. -.  
 (c) If assertion is true and reason is false.  
 (d) If both assertion and reason are false.
- 77) **Assertion:** The extent of refraction is different for different medium.  
**Reason:** Different medium have different refractive index.  
**Codes**  
 (a) If both assertion and reason are true and the reason is correct explanation of assertion.  
 (b) If both assertion and reason are true but reason is not a correct explanation of assertion. -.  
 (c) If assertion is true and reason is false.  
 (d) If both assertion and reason are false.
- 78) **Assertion:** Focal length of concave mirror is +ve  
**Reason:** Focal length of convex mirror is -ve  
**Codes**  
 (a) If both assertion and reason are true and the reason is correct explanation of assertion.  
 (b) If both assertion and reason are true but reason is not a correct explanation of assertion. -.  
 (c) If assertion is true and reason is false.  
 (d) If both assertion and reason are false.



- 79) **Assertion:** When a ray enter from air to water obliquely, it bends toward the normal.  
**Reason:** It is because water is denser medium than air.  
**Codes**  
(a) If both assertion and reason are true and the reason is correct explanation of assertion.  
(b) If both assertion and reason are true but reason is not a correct explanation of assertion. -.  
(c) If assertion is true and reason is false.  
(d) If both assertion and reason are false.
- 80) **Assertion:** Parallel rays meet at focus after refraction.  
**Reason:** Rays from distant objects are parallel rays.  
**Codes**  
(a) If both assertion and reason are true and the reason is correct explanation of assertion.  
(b) If both assertion and reason are true but reason is not a correct explanation of assertion.  
(c) If assertion is true and reason is false.  
(d) If both assertion and reason are false.
- 81) **Assertion:** If a ray of light is incident on a convex mirror along its principal axis, then the angle of incidence as well as the angle of reflection for a ray of light will be zero.  
**Reason:** A ray of light going towards the centre of curvature of a convex mirror is reflected back along the same path.  
**Codes**  
(a) Both A and R are true, and R is correct explanation of the assertion.  
(b) Both A and R are true, but R is not the correct explanation of the assertion.  
(c) A is true, but R is false.  
(d) A is false, but R is true.
- 82) **Assertion:** Linear magnification of a mirror has no unit.  
**Reason:** The ratio of height of the image to the height of the object is the linear magnification produced by mirror.  
**Codes**  
(a) Both A and R are true, and R is correct explanation of the assertion.  
(b) Both A and R are true, but R is not the correct explanation of the assertion.  
(c) A is true, but R is false.  
(d) A is false, but R is true
- 83) **Assertion:** Light is able to reach earth from the sun.  
**Reason:** Light rays can travel in vaccum.  
**Codes**  
(a) Both A and R are true, and R is correct explanation of the assertion.  
(b) Both A and R are true, but R is not the correct explanation of the assertion.  
(c) A is true, but R is false.  
(d) A is false, but R is true
- 84) **Assertion:** Property of converging of a convergent lens does not remain same in all media.  
**Reason :** Property of lens whether the ray is diverging or converging is independent of the surrounding medium.  
**Codes**  
(a) Both A and R are true, and R is correct explanation of the assertion.  
(b) Both A and R are true, but R is not the correct explanation of the assertion.  
(c) A is true, but R is false.  
(d) A is false, but R is true

- 85) **Assertion:** We can decide the nature of a mirror by observing the size of erect image in the mirror.

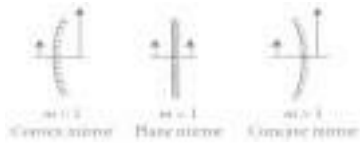

**Reason:** The minimum distance between a real object and its real image in a concave mirror is non zero.

**Codes**

- (a) Both A and R are true, and R is correct explanation of the assertion.  
(b) Both A and R are true, but R is not the correct explanation of the assertion.  
(c) A is true, but R is false.  
(d) A is false, but R is true
- 86) **Assertion:** A convex lens is made of two different materials. A point object is placed on the principal axis. The number of images formed by the lens will be two.  
**Reason:** The image formed by convex lens is always virtual.  
**Codes**  
(a) Both A and R are true, and R is correct explanation of the assertion.  
(b) Both A and R are true, but R is not the correct explanation of the assertion.  
(c) A is true, but R is false  
(d) A is false, but R is true.
- 87) **Assertion:** In diffused reflection, a parallel beam of incident light is reflected in different direction.  
**Reason:** The diffused reflection of light is due to the failure of the laws of reflection.  
**Codes**  
(a) Both A and R are true, and R is correct explanation of the assertion.  
(b) Both A and R are true, but R is not the correct explanation of the assertion.  
(c) A is true, but R is false.  
(d) A is false, but R is true
- 88) **Assertion:** The image of a virtual object formed by a thin converging lens is always real.  
**Reason:** In the case of a thin lens,  $\frac{1}{v} - \frac{1}{u} = \frac{1}{f}$   
**Codes**  
(a) Both A and R are true, and R is correct explanation of the assertion.  
(b) Both A and R are true, but R is not the correct explanation of the assertion.  
(c) A is true, but R is false.  
(d) A is false, but R is true.
- 89) **Assertion:** In the case of concave mirror, the minimum distance between real object and its real image is zero.  
**Reason:** If concave mirror forms virtual image of real object, the image is magnified.  
**Codes**  
(a) Both A and R are true, and R is correct explanation of the assertion.  
(b) Both A and R are true, but R is not the correct explanation of the assertion.  
(c) A is true, but R is false.  
(d) A is false, but R is true.
- 90) **Assertion:** The size of the mirror affect the nature of the image.  
**Reason:** Small mirrors always form virtual images.  
**Codes**  
(a) Both A and R are true, and R is correct explanation of the assertion.  
(b) Both A and R are true, but R is not the correct explanation of the assertion.  
(c) A is true, but R is false.  
(d) A is false, but R is true.

- 91) **Assertion:** Keeping a point object fixed, if a plane mirror is moved, the image will also move.  
**Reason :** In case of a plane mirror, distance of object and its image is equal from any point on the mirror.  
**Codes**  
 (a) Both A and R are true, and R is correct explanation of the assertion.  
 (b) Both A and R are true, but R is not the correct explanation of the assertion.  
 (c) A is true, but R is false.  
 (d) A is false, but R is true.
- 92) **Assertion:** A plane mirror neither converges parallel rays of light nor diverges them.  
**Reason:** The focal length of a plane mirror can be considered to be infinite.  
**Codes**  
 (a) Both A and R are true, and R is correct explanation of the assertion.  
 (b) Both A and R are true, but R is not the correct explanation of the assertion.  
 (c) A is true, but R is false.  
 (d) A is false, but R is true.

Passage Based Questions

4 x 1 = 4

- 93) The following diagram is of the solar furnace. It is used to generate heat using sun radiation. The solar furnace consists of flat solar tracking heliostat, a parabolic collecting mirror, an attenuator or shutter, and the test zone area.

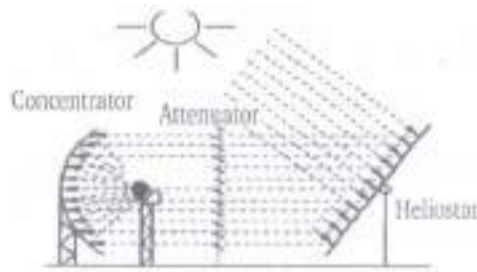

Answer the following questions based on the above information

- (a) Name the parabolic mirror used in this process.  
 (b) Suggest one material that can be used as a heliostat surface to reflect maximum radiation.  
 (c) The device that can control the amount of light entering the furnace.  
 (d) Name the device that is used to cook food using sunlight.
- 94) The atmosphere reflects, scatters, and absorbs solar radiation, reducing the amount of sunlight that reaches Earth's surface. Some atmospheric gases absorb specific wavelengths of solar radiation. Water vapour is a strong absorber of incoming infrared energy, causing a significant reduction in the amount of solar radiation reaching the ground during humid conditions. Ozone, during its formation and dissociation, absorbs harmful ultraviolet radiation that can lead to sunburn and skin cancer. Haze, dust, smoke, and air pollutants in general block incoming solar energy to some extent wherever present. Clouds strongly reflect, scatter, and absorb incoming sunlight. High, thin cirrus absorb some sunlight while dense clouds, if thick enough, can produce almost night time conditions.  
 Answer the following questions based on the above information  
 (a) List three factors that affect the light reaching the earth's surface from sun.  
 (b) The atmosphere scatters the light, how is this phenomenon possible?  
 (c) Name three different types of radiation emitted by sunlight.  
 (d) What is the range of wavelength of sunlight?
- 95) **Double convex lens:** If both the spherical surfaces are bulging outwards, it is called double convex lens. It is thicker at the middle and thinner on edges, it is convex lens. Convex lens converges a parallel beam of light, so it is called a converging lens.  
**Double concave lens:** If both the spherical surfaces are curved inward, it is called double concave lens. It is a diverging lens. It is thicker on the edges but thinner at the middle.  
 Answer the following questions based on the above information  
 (a) Is it possible for a lens to act as convergent lens in one medium and a divergent lens in another?  
 (b) What happens to the image formed by a convex lens if its lower part is blackened?  
 (c) What type of lenses and of what focal length (50 cm or 5 cm) would you prefer to use while reading small letters in the dictionary?  
 (d) Two thin lenses of power +3.5 D and -2.5 D are placed in contact with each other.  
 Find the power and focal length of the lens combination.

- 96) Is there a relationship between the radius of curvature  $R$ , and focal length  $f$ , of a spherical mirror? For spherical mirrors of small apertures, the radius of curvature is found to be equal to twice the focal length. We put this as  $R = 2f$ . This implies that the principal focus of a spherical mirror lies midway between the pole and centre of curvature.

Answer the following questions based on the above information

- Write relation between radius of curvature and focal length.
- For which type of mirrors above relation is verified?
- What should be the size of the aperture?
- Where is principal focus of a spherical mirror lies?

Data Based Questions

1 x 1 = 1

- 97) Analyse the following observation table showing variation of image distance ( $v$ ) with object distance ( $u$ ) in case of a convex lens and answer the questions that follow, without doing any calculations:

S.No	Object distance $u$ (cm)	Image distance $v$ (cm)
1	-90	+18
2	-60	+20
3	-30	+30
4	-20	+60
5	-18	+90
6	-10	+100

Answer the following questions based on the above information

- What is the focal length of the convex lens? Give reason in support of your answer.
- Write the serial number of that observation which is not correct. How did you arrive at this conclusion?
- The approximate value of magnification in case of S.No. 4 is  
(i) -2 (ii) -3 (iii) +3 (iv) +2
- The image formed in case of S.No. 2 is  
(i) virtual and enlarged  
(ii) virtual and diminished  
(iii) real and diminished  
(iv) real and enlarged

2 Marks

174 x 2 = 348

- Define the principal focus of a concave mirror .
- Name a mirror that can give an erect and enlarged image of an object.
- Why do we prefer a convex mirror as a rear view mirror in vehicles?
- A ray of light travelling in air enters obliquely into water. Does the light ray bend towards the normal or from the normal? Why?
- The refractive index of diamond is 2.42. What is the meaning of this statement?
- Define 1 dioptre of power of a lens
- Find the focal length of a lens of power - 2 D. What type of lens is this?
- A doctor has prescribed a corrective lens of power + 1.5 D. Find the focal length of the lens. Is the prescribed lens diverging or converging?
- Find the power of a concave lens of focal length 2m.
- How do you find the rough focal length of a convex lens? Is the same method applicable to a concave lens?
- What are the factors that determine the focal length of a lens?
- Does the method to find the approximate focal length of a convex lens is applicable to concave lens?
- State mirror formula. How does it change when object distance  $u$  from the mirror is changed?

- 111) The formula for linear magnification of a spherical mirror is  $m = \frac{h_2}{h_1} = \frac{-v}{u}$ . What determines the sign of m? What is the significance of this sign?
- 112) Identify the device used as a spherical mirror or lens in following cases, when the image formed is virtual and erect in each case.
- Object is placed between device and its focus, image formed is enlarged and behind it.
  - Object is placed between the focus and device, image formed is enlarged and on the same side as that of the object.
  - Object is placed between infinity and device, image formed is diminished and between focus and optical centre on the same side as that of the object.
  - Object is placed between infinity and device, image formed is diminished and between pole and focus, behind it.
- 113) Why does a light ray incident on a rectangular glass slab immersed in any medium emerges parallel to itself? Explain using a diagram.
- 114) How is the refractive index of a medium related to the speed of light? Obtain an expression for refractive index of a medium with respect to another in terms of speed of light in these two media?
- 115) Refractive index of diamond with respect to glass is 1.6 and absolute refractive index of glass is 1.5. Find out the absolute refractive index of diamond.
- 116) A convex lens of focal length 20 cm can produce a magnified virtual as well as real image. Is this a correct statement? If yes, where shall the object is placed in each case for obtaining these images?
- 117) Shoba finds out that sharp image of the window pane of her science laboratory is formed at a distance of 15 cm from the lens. She now tries to focus the building visible to her outside the window instead of the window pane without disturbing the lens. In which direction will she move the screen to obtain a sharp image of the building? What is the approximate focal length of this lens?
- 118) How are power and focal length of a lens related? You are provided with two lenses of focal length 20 cm and 40 cm respectively. Which lens will you use to obtain more convergent light?
- 119) Under what condition in an arrangement of two plane mirrors, incident ray and reflected ray will always be parallel to each other, whatever may be angle of incidence. Show the same with the help of diagram.
- 120) Draw a ray diagram showing the path of rays of light when it enters with oblique incidence (i) from air into water; (ii) from water into air.
- 121) Where is the image formed in a convex mirror, when the object is anywhere in front of it?
- 122) Between which two points related to a concave mirror should an object be placed to obtain on a screen of an image twice the size of the object?
- 123) A person uses concave mirror for shaving, where should he position his face in front of it?
- 124) What is meant by power of a lens?
- 125) A ray of light is incident on a concave mirror along its principal axis. What will be the angle of reflection?
- 126) What will happen to ray of light when it travels from rarer medium to a denser medium?
- 127) What does negative sign in the value of magnification of a mirror indicate?
- 128) Between which two points of a concave mirror should an object be placed to obtain a magnification of -3?
- 129) Name the point inside the lens through which a ray of light goes undeviated.
- 130) The speed of light in a transparent medium is 0.6 times that of its speed in vacuum. What is the refractive index of the medium?
- 131) Which of the two has a great power? A lens of short focal length or a lens of large focal length
- 132) Name the lens which always gives an erect and diminished image?

- 133) Which mirror is used as rear view mirror in vehicles and why?
- 134) The outer surface of a hollow sphere of aluminium of radius 50 cm is to be used as a mirror. What will be the focal length of this mirror? Which type of spherical mirror will it provide?
- 135) Define one dioptre.
- 136) The size of an object is 2 cm. The magnification produced by a mirror is +1. What is the size of the image?
- 137) When a ray of light passes from a denser medium to a rarer medium which angle is greater? Angle of incidence or angle of refraction
- 138) "The refractive index of carbon disulphide is 1.63." What is the meaning of this statement in relation to speed of light?
- 139) An image formed in a spherical mirror has magnification -2. Is the image real or virtual?
- 140) A ray of light enters a rectangular glass slab of refractive index 1.5. It is found that the ray emerges from the opposite face of the slab without being displaced. If its speed in air is  $3 \times 10^8$  m/s, then what is its speed in glass?
- 141) The power of a lens is - 2D. Is the lens convex or concave?
- 142) Focal length of a convex mirror is 10 cm. Find the radius of curvature of the mirror.
- 143) What is the nature of the image formed by a concave mirror if the magnification produced by the mirror is +3?
- 144) An object is placed at a distance of 50 cm from a convex mirror. State two characteristics of the image formed.
- 145) A girl was playing with a thin beam of light from her laser torch by directing it from different directions on a convex lens held vertically. She was surprised to see that in a particular direction the beam of light continues to move along the same direction after passing through the lens. State the reason for this observation.
- 146) Give uses of concave mirror.
- 147) An object 1 cm high produces a real image 1.5 cm high, when placed at a distance of 15 cm from concave mirror. Calculate the position of the image.
- 148) How should a ray of light be incident on a rectangular glass slab so that it comes out from the opposite side of the slab without being displaced?
- 149) Which phenomenon occurs when light falls on  
(a) highly polished surface  
(b) a transparent medium?
- 150) What will happen to ray of light when it falls normally on a surface?
- 151) What is absolute refractive index?
- 152) Explain why a ray of light passing through the centre of curvature of a concave mirror, gets reflected along the same path?
- 153) If refractive index of glass is 1.65, what is the speed of light in glass?
- 154) What is the magnification of the images formed by plane mirror and why?
- 155) "The magnification 'm' for a mirror is +1." What does this signify?
- 156) The image formed by a concave mirror is observed to be virtual, erect and larger than the object. Where should the position of the object be relative to the mirror? Draw ray diagram to justify your answer.
- 157) Draw the ray diagram and also state the position, the relative size and the nature of image formed by a concave mirror when the object is placed at the centre of curvature of the mirror.

- 158) Define, 'refractive index of a transparent medium,' What is its unit? Which has a higher refractive index? glass or water?
- 159) List four properties of the image formed by a concave mirror when object is placed between focus and pole of the mirror.
- 160) A ray of light falls normally on the surface of a transparent glass slab. Draw a ray diagram to show its path and also mark angle of incidence and angle of emergence.
- 161) List four characteristics of the images formed by plane mirrors.
- 162) State two positions in which a concave mirror produces a magnified image of a give object. List two different between the two images.
- 163) List four specific characteristics of the images of the objects formed by convex mirrors.
- 164) The image of a candle flame placed at a distance of 30 cm from a spherical lens is formed on a screen placed on the other side of the lens at a distance of 60 cm from the optical centre of the lens. Identify the type of lens and calculate its focal length. If the height of the flame is 3 cm, find the height of its imaged.
- 165) To construct a ray diagram we use two rays of light which are so chosen that it is easy to determine their directions after reflection from the mirror. Choose these two rays and state the path of these rays after reflection from a concave mirror. Use these two rays to find the nature and position of the image of an object placed at a distance of 15 cm from a concave mirror of focal length 10 cm.
- 166) Draw the following diagram, in which a ray of light is incident on a concave , convex mirror, on your answer sheet. Show the path of this ray, after reflection, in each case.

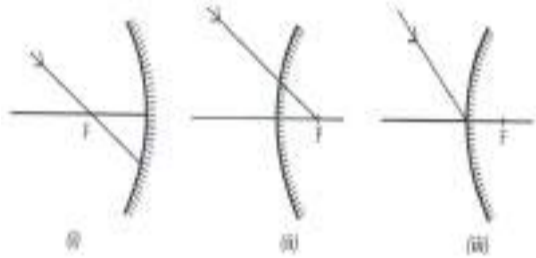

- 167) What is meant by power of lens? What does its sign (+ve od -ve) indicate? State its S.I. unit. How is this unit related to focal length of a lens?
- 168) Draw a ray diagram to show the path of the reflected ray corresponding to an incident ray which is directed towards the principal focus of a convex mirror. Mark on the angle of incidence and the angle of reflection.
- 169) "A ray of light incident on a rectangular glass slab immersed in any medium emerges parallel to itself." Draw a labelled ray diagram to justify the statement?
- 170) Mention the types of mirrors used as  
 (i) rear view mirrors.  
 (ii) Shaving mirrors.  
 List two reasons to justify your answers in each case.
- 171) State the type of mirror preferred as  
 (i) rear view mirror in vehicles  
 (ii) shaving mirror.  
 Justify your answer giving two reasons each case.
- 172) A student wants to project the image of a candle flame on a screen 60 cm in front of a mirror by keeping the flame at a distance of 15 cm from its pole.  
 (i) Write the type of mirror he should use.  
 (ii) Find the linear magnification of the image produced.  
 (iii) What is the distance between the object and its image?  
 (iv) Draw a ray diagram to show the image formation in this case.
- 173) A ray of light travelling in air enters obliquely into water, the light ray will bend towards or away from the normal? Why? Draw a ray diagram to show the refraction of light in this situation.

- 174) (i) "The refractive index of diamond is 2.42." What is the meaning of this statement?  
(ii) Name a liquid whose mass density is less than that of water but it is optically denser than water.
- 175) Name the type of mirrors used in the design of solar furnaces. Explain how high temperature is achieved by this device.
- 176) "The magnification produced by a spherical mirror is -3." List four information's you obtain from this statement about the mirror/ image.
- 177) The image of an object formed by a lens is of magnification -1. If the distance between the object and its image is 60 cm, what is the focal length of the lens? If the object moved 20 cm towards the lens. Where would the image be formed? State reason and also draw a ray diagram in support of your answer.
- 178) The refractive indices of glass and water with respect to air are  $\frac{3}{2}$  and  $\frac{4}{3}$  respectively. If speed of light in glass is  $2 \times 10^8$  m/s, find the speed of light in water.
- 179) A ray of light is incident on a convex mirror as shown. Redraw the diagram and complete the path of this ray after reflection from the mirror. Mark angle of incidence and angle of reflection on it.

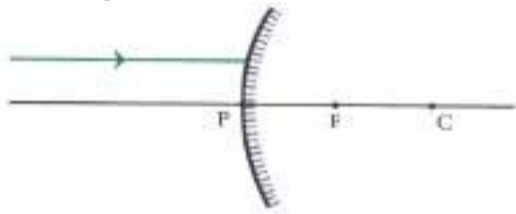

- 180) What is light?
- 181) Name some phenomenon associated with light during image formation by mirrors.
- 182) Define reflection of light
- 183) State laws of reflection.
- 184) What are spherical mirrors?
- 185) Give uses of convex mirrors
- 186) Give the relation between focal length and radius of curvature.
- 187) Define refraction of light.
- 188) Define lateral displacement
- 189) Define absolute refractive index.
- 190) What is the unit of refractive index?
- 191) Define optical density
- 192) Define a lens
- 193) What is the magnification of a plane mirror?
- 194) What is the radius of curvature of plane mirror
- 195) Which lens bends a light ray more or less with a shorter or with longer focal length
- 196) If a convex lens is used to focus sunlight on a paper, where the paper should be placed so that it catches fire.
- 197) What happens if a light falls on a glass slab making  $90^\circ$  at its surface?
- 198) Where should be an object placed in front of convex lens so as to use it as a magnifier?
- 199) What is silvering of mirror?
- 200) Amit visited a fair and saw a mirror in which he got a very funny image. The above part of his body was big in size, middle part was of normal size and the lower part of the body showed very small size. What kind of mirror is this?



- 201) Nidhi wanted the image of her pencil to be double the size of its original size. Name the mirror used for getting such image
- 202) Give the mirror image of 'AMBULANCE'
- 203) What are the two types of reflection?
- 204) What are the two types of refractive index?
- 205) Give characteristics of image formed by plane mirror
- 206) Give uses of plane mirror.
- 207) Name two types of spherical mirror
- 208) An incident ray makes an angle of  $60^\circ$  with the mirror. What is the angle of reflection?
- 209) A student finds the focal length of the convex lens and records it as given below:  
10 cm, 10.6 cm, 10.5 cm and 10.5 cm.  
Which reading he should discard and why?
- 210) Suggest how can one avoid the errors liuring measuring the focal length of the given lens
- 211) A student wants to find the refractive index of the glass slab given to him. What are the materials required to study the same in the lab? Give the formula to calculate the refractive index.
- 212) Explain how practically you can identify the concave lens and convex lens in the lab. Justify your answer
- 213) If you have to construct a microscope to view the minute objects and magnify them, suggest how will you do it practically and what is the material required for the same.
- 214) The below diagram is used to study how light travels through a glass slab.  
(a) On the figure draw the normal rayon side AB.  
(b) Join dots  $P_3$  and  $P_4$ , draw normal at side CD and measure angle formed here.  
(c) Name this angle.  
(d) At side AB draw angle of incidence with 30 degree.

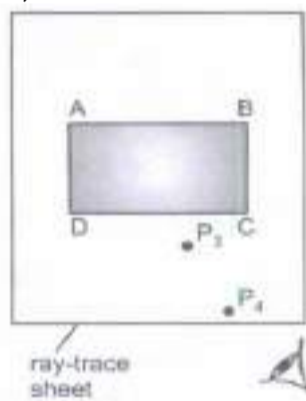

- 215) State the laws of reflection of light
- 216) What are the properties of the image formed by plane mirror?
- 217) Define pole and centre of curvature of spherical mirrors.
- 218) Write the position, nature and size of images formed by concave mirror.
- 219) What is refractive index?
- 220) What is absolute refractive index of the medium?
- 221) Two medium with refractive index 1.31 and 1.50 are given. In which case  
(i) bending of light is more?  
(ii) speed of light is more?
- 222) Refractive index of kerosene oil is 1.44 and that of water is 1.33. A ray of light enters from kerosene oil to water. Where would light ray bend and why?
- 223) Which is optically denser out of the two medium  $M_1 = 1.71$  (refractive index) and  $M_2 = 1.36$  (refractive index). How does speed of light change when it travels from optically rarer to denser medium.

- 224) Comment on the size, position of the image formed by a concave mirror of focal length 18 cm when an object is placed:  
 (i) at 22 cm (ii) 14 cm (iii) 40 cm. in front of mirror without calculations.
- 225) With the help of a ray diagram show how a pencil appears when dipped in water.
- 226) The refractive index of water is 1.33 and kerosene is 1.44. Calculate the refractive index of kerosene with respect to water.
- 227) Why does a ray of light bend when it travels from one medium into another?
- 228) What kind of mirrors are used in big shopping stores to watch activities of customers?
- 229) Draw a ray diagram to determine the position of image formed of an object placed between the pole and the focus of a concave mirror.
- 230) State the mirror formula, lens formula and power of lens
- 231) What are the minimum number of rays required for locating the image formed by a concave mirror for an object? Draw a ray diagram to show the formation of virtual image by a concave mirror.
- 232) Define and show on a diagram, the following terms relating to a concave mirror: (i) Aperture (ii) Radius of curvature
- 233) Define the focus of a concave mirror. If the radius of curvature of a convex mirror is 30 cm, what Radius of curvature would be its focal length?
- 234) Distinguish between a real and a virtual image of an object. What type of image is formed (i) by a plane mirror, (ii) on a cinema screen
- 235) Draw a ray diagram and also state the position, the relative size and the nature of image formed by a concave mirror when the object is placed at the centre of curvature of the mirror
- 236) An object is placed between infinity and the pole of a convex mirror. Draw a ray diagram and also state the position, the relative size and the nature of the image formed.
- 237) What is understood by lateral displacement of light? Illustrate it with the help of a diagram. List any two factors on which the lateral displacement of a particular substance depends.
- 238) Draw the ray diagram and also state the position, relative size and nature of the image formed by a concave mirror when the object is placed between its centre of curvature, C and focus, F.

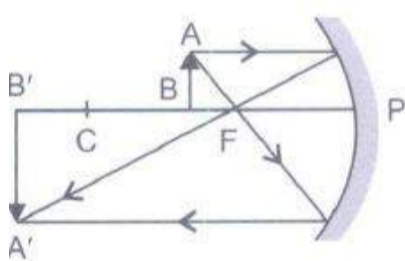

- 239) What are the properties of image formed by a plane mirror?
- 240) List four properties of the image formed by a convex mirror.
- 241) State the type of mirror preferred as (i) rear view mirror in vehicles, shaving mirror. Justify your answer giving two reasons in each case.
- 242) AB and CD, two spherical mirrors, form parts of a hollow spherical ball with its centre at O as shown in diagram. If arc AB =  $\frac{1}{2}$  arc CD, what is the ratio of their focal lengths? State which of the two mirrors will always form virtual image of an object placed in front of it why?

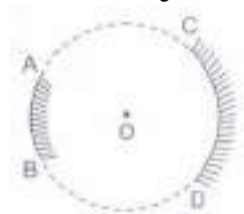

- 243) If a light ray 1M is incident on the surface AB as shown, identify the correct emergent ray

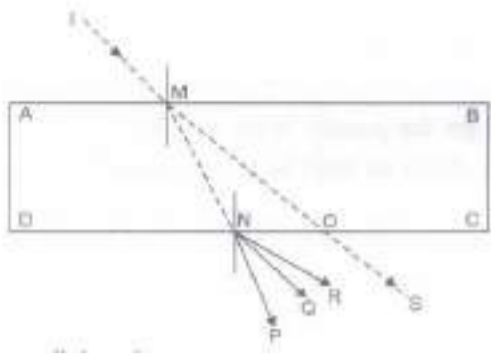

- 244) Define magnification of mirror
- 245) State laws of refraction.
- 246) What do you observe when light ray passes through rectangular slab?
- 247) State lens formula and write it mathematically.
- 248) Define pole, centre of curvature, radius of curvature, principal axis, aperture, focus and focal length of a spherical mirror.
- 249) Define refractive index.
- 250) Define magnification of lens.
- 251) What are the two types of lenses?
- 252) Write nature, position and relative size of image formed by convex lens.
- 253) Give sign conventions for spherical lenses.
- 254) Give the sign conventions for spherical mirrors.
- 255) Define incident ray, reflected ray, normal ray, angle of incidence and reflection.
- 256) What is the relation between optical density, refractive index and speed of light?
- 257) Write nature, position and relative size of image formed by concave lens.
- 258) Define power of a lens.
- 259) What is the S.I unit of power? Define it.
- 260) Give the uses of concave mirrors.
- 261) List four properties of the image formed by a plane mirror.
- 262) Write the laws of reflection
- 263) Which kind of mirrors are used in the headlights of a motor-car and why?
- 264) The power of a lens is  $-4.0\text{ D}$ . What is the nature of this lens?
- 265) A ray is Incident on a plane mirror as shown in figure.

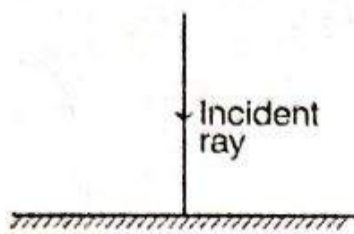

What is the angle of reflection for the above incident ray?

- 266) Where is the image formed when an object is at large distance from a concave mirror?
- 267) The image formed by a concave mirror is observed to be real, inverted and larger than the object. Where is the object placed?

- 268) A lens made of material with refractive index 1.5 is immersed in a liquid with refractive index 1.5. The diagram below shows two rays incident on the lens when it is immersed in the liquid.

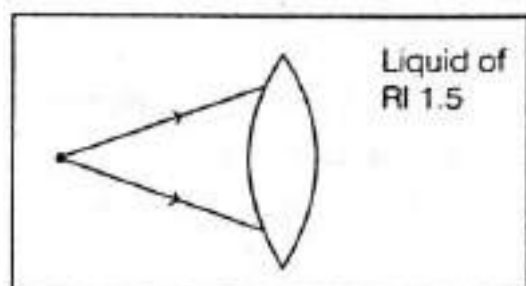

Copy the diagram and draw the light rays after they pass through the lens. Justify your diagram.

- 269) Name the part of a lens through which a ray of light passes without suffering any deviation.
- 270) Both a spherical mirror and a thin spherical lens have a focal length of (-15) cm. What type of mirror and lens are these?
- 271) Redraw the ray diagram given below in your answer book and complete the path of ray.

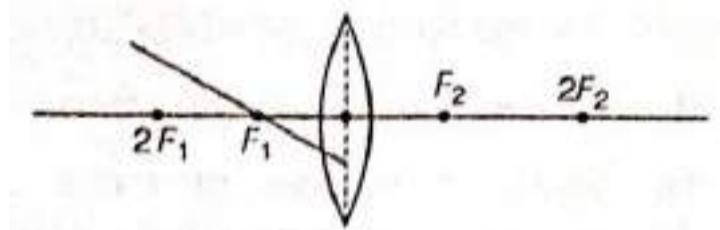

#### Activity Based Questions

13 x 2 = 26

- 272)
- 1) Take a large shining spoon. Try to view your face in its curved surface.
  - 2) Do you get the image? Is it smaller or larger?
  - 3) Move the spoon slowly away from your face. Observe the image. How does it change?
  - 4) Reverse the spoon and repeat the Activity. How does the image look like now?
  - 5) Compare the characteristics of the image on the two surfaces.
- 273) **CAUTION:** Do not look at the Sun directly or even into a mirror reflecting sunlight. It may damage your eyes.
1. Hold a concave mirror in your hand and direct its reflecting surface towards the Sun.
  2. Direct the light reflected by the mirror on to a sheet of paper held close to the mirror.
  3. Move the sheet of paper back and forth gradually until you find on the paper sheet a bright, sharp spot of light.
  4. Hold the mirror and the paper in the same position for a few minutes. What do you observe? Why?

- 274) You have already learnt a way of determining the focal length of a concave mirror. you have seen that the sharp bright spot of light you got on the paper is, in fact, the image of the Sun. It was a tiny, real, inverted image. You got the approximate focal length of the concave mirror by measuring the distance of the image from the mirror.
- 1) Take a concave mirror. Find out its approximate focal length in the way described above. Note down the value of focal length. (You can also find it out by obtaining image of a distant object on a sheet of paper.)
  - 2) Mark a line on a Table with a chalk. Place the concave mirror on a stand. Place the stand over the line such that its pole lies over the line.
  - 3) Draw with a chalk two more lines parallel to the previous line such that the distance between any two successive lines is equal to the focal length of the mirror. These lines will now correspond to the positions of the points P, F and C, respectively. Remember – For a spherical mirror of small aperture, the principal focus F lies mid-way between the pole P and the centre of curvature C.
  - 4) Keep a bright object, say a burning candle, at a position far beyond C. Place a paper screen and move it in front of the mirror till you obtain a sharp bright image of the candle flame on it.
  - 5) Observe the image carefully. Note down its nature, position and relative size with respect to the object size.
  - 6) Repeat the activity by placing the candle –
    - (a) just beyond C,
    - (b) at C,
    - (c) between F and C,
    - (d) at F, and
    - (e) between P and F.
  - 7) In one of the cases, you may not get the image on the screen. Identify the position of the object in such a case. Then, look for its virtual image in the mirror itself.
- Note down and tabulate your observations.

- 275) 1) Draw neat ray diagrams for each position of the object shown in Table .
- 2) You may take any two of the rays mentioned in the previous section for locating the image.
  - 3) Compare your diagram with those given in Fig.
  - 4) Describe the nature, position and relative size of the image formed in each case.
  - 5) Tabulate the results in a convenient format.

<b>Position of the object</b>	<b>Position of the image</b>	<b>Size of the Image</b>	<b>Nature of the image</b>
At infinity	At the focus F	Highly diminished point-sized	Real and inverted
Beyond C	Between F and C	Diminished	Real and inverted
At C	At C	Same size	Real and inverted
Between C and F	Beyond C	Enlarged	Real and inverted
At F	At infinity	Highly enlarged	Real and inverted
Between P and F	Behind the mirror	Enlarged	Virtual and erect

- 276) 1) Take a convex mirror. Hold it in one hand.
- 2) Hold a pencil in the upright position in the other hand.
  - 3) Observe the image of the pencil in the mirror. Is the image erect or inverted? Is it diminished or enlarged?
  - 4) Move the pencil away from the mirror slowly. Does the image become smaller or larger?
  - 5) Repeat this Activity carefully. State whether the image will move closer to or farther away from the focus as the object is moved away from the mirror?

- 277) 1) Observe the image of a distant object, say a distant tree, in a plane mirror.  
 2) Could you see a full-length image?  
 3) Try with plane mirrors of different sizes. Did you see the entire object in the image?  
 4) Repeat this Activity with a concave mirror. Did the mirror show full length image of the object?  
 5) Now try using a convex mirror. Did you succeed? Explain your observations with reason.
- 278) 1) Place a coin at the bottom of a bucket filled with water.  
 2) With your eye to a side above water, try to pick up the coin in one go. Did you succeed in picking up the coin?  
 3) Repeat the Activity. Why did you not succeed in doing it in one go?  
 4) Ask your friends to do this. Compare your experience with theirs.
- 279) 1) Place a large shallow bowl on a Table and put a coin in it.  
 2) Move away slowly from the bowl. Stop when the coin just disappears from your sight.  
 3) Ask a friend to pour water gently into the bowl without disturbing the coin.  
 4) Keep looking for the coin from your position. Does the coin becomes visible again from your position? How could this happen?
- 280) 1) Draw a thick straight line in ink, over a sheet of white paper placed on a Table.  
 2) Place a glass slab over the line in such a way that one of its edges makes an angle with the line.  
 3) Look at the portion of the line under the slab from the sides. What do you observe?  
 4) Does the line under the glass slab appear to be bent at the edges?  
 5) Next, place the glass slab such that it is normal to the line. What do you observe now?  
 6) Does the part of the line under the glass slab appear bent?  
 7) Look at the line from the top of the glass slab. Does the part of the line, beneath the slab, appear to be raised? Why does this happen?
- 281) 1) Fix a sheet of white paper on a drawing board using drawing pins.  
 2) Place a rectangular glass slab over the sheet in the middle.  
 3) Draw the outline of the slab with a pencil. Let us name the outline as ABCD.  
 4) Take four identical pins.  
 5) Fix two pins, say E and F, vertically such that the line joining the pins is inclined to the edge AB.  
 6) Look for the images of the pins E and F through the opposite edge.  
 7) Fix two other pins, say G and H, such that these pins and the images of E and F lie on a straight line.  
 8) Remove the pins and the slab.  
 9) Join the positions of tip of the pins E and F and produce the line up to AB. Let EF meet AB at O.  
 Similarly, join the positions of tip of the pins G and H and produce it up to the edge CD. Let HG meet CD at O'.  
 10) Join O and O'. Also produce EF up to P, as shown by a dotted line in Fig.

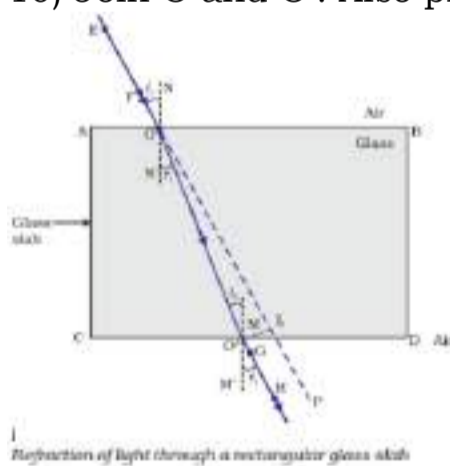

- 282) **CAUTION:** Do not look at the Sun directly or through a lens while doing this Activity or otherwise. You may damage your eyes if you do so.
- 1) Hold a convex lens in your hand. Direct it towards the Sun.  
 2) Focus the light from the Sun on a sheet of paper. Obtain a sharp bright image of the Sun.  
 3) Hold the paper and the lens in the same position for a while. Keep observing the paper. What happened? Why?

- 283) 1) Take a convex lens. Find its approximate focal length in a way described in  
**CAUTION:** Do not look at the Sun directly or through a lens while doing this Activity or otherwise. You may damage your eyes if you do so.  
 (i) Hold a convex lens in your hand. Direct it towards the Sun.  
 (ii) Focus the light from the Sun on a sheet of paper. Obtain a sharp bright image of the Sun.  
 (iii) Hold the paper and the lens in the same position for a while. Keep observing the paper. What happened? Why?  
 (2) Draw five parallel straight lines, using chalk, on a long Table such that the distance between the successive lines is equal to the focal length of the lens.  
 (3) Place the lens on a lens stand. Place it on the central line such that the optical centre of the lens lies just over the line.  
 (4) The two lines on either side of the lens correspond to  $F$  and  $2F$  of the lens respectively. Mark them with appropriate letters such as  $2F_1$ ,  $F_1$ ,  $F_2$  and  $2F_2$ , respectively.  
 5) Place a burning candle, far beyond  $2F_1$  to the left. Obtain a clear sharp image on a screen on the opposite side of the lens.  
 6) Note down the nature, position and relative size of the image.  
 7) Repeat this Activity by placing object just behind  $2F_1$ , between  $F_1$  and  $2F_1$  at  $F_1$ , between  $F_1$  and  $O$ . Note down and tabulate your observations.

- 284) 1) Take a concave lens. Place it on a lens stand.  
 2) Place a burning candle on one side of the lens.  
 3) Look through the lens from the other side and observe the image.  
 Try to get the image on a screen, if possible. If not, observe the image directly through the lens.  
 4) Note down the nature, relative size and approximate position of the image.  
 5) Move the candle away from the lens. Note the change in the size of the image. What happens to the size of the image when the candle is placed too far away from the lens.

3 Marks

45 x 3 = 135

- 285) The radius of curvature of a spherical mirror is 20cm. What is its focal length?  
 286) Find the focal length of a convex mirror whose radius of curvature is 32cm.  
 287) A concave mirror produces three times magnified (enlarged) real image of object placed at 10 cm in front of it. Where is the image located?  
 288) Light enters from air to glass having refractive index 1.50. What is the speed of light in the glass? The speed of light in vacuum is  $3 \times 10^8 \text{ ms}^{-1}$ .  
 289) The magnification produced by a plane mirror is +1. What does it mean?  
 290) Define the following.  
 (a) What is ray? (b) What is beam?  
 (c) What is reflection of light? (d) What is reflector?  
 (e) What is focal length? (f) What is principal focus?  
 (g) What is refraction? (h) What is optically rarer medium?  
 (i) What is optically denser medium? (j) What is power?  
 (k) What is 1 dioptre?

- 291) Complete the following ray diagrams

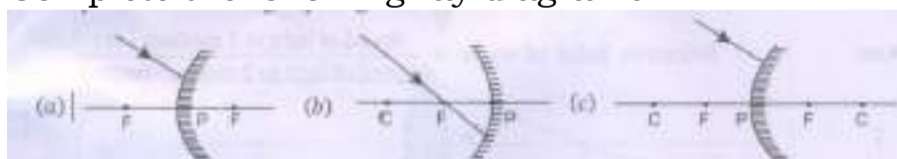

- 292) Define power of lens. What is the S. I. unit of power of a lens? If power of lens is +2D what is the nature and focal length of the lens?

- 293) Redraw the given diagram and show the path of the refracted ray.

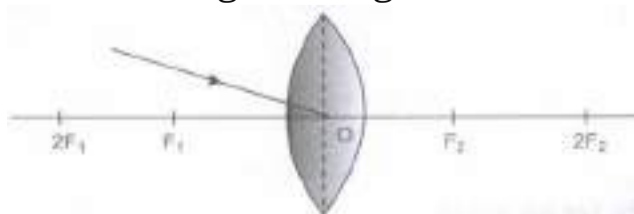

- 294) Draw the given diagram in your answer book and complete it for the path of ray of light beyond the lens

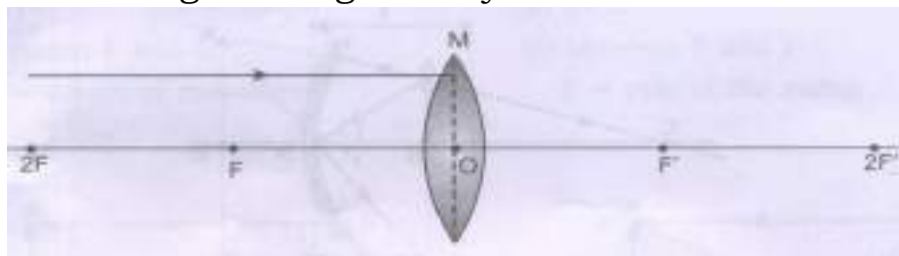

- 295) Take down this diagram on to your answer book and complete the path of the ray.



- 296) Draw ray diagrams to show the image formed by a concave lens for the object placed at  
 (i) infinity  
 (ii) Between  $f$  and  $2f$  of the lens.
- 297) If the image formed by a lens for all positions of the object placed in front of it is always virtual, erect and diminished, state the type of the lens. Draw a ray diagram in support of your answer. If the numerical value of focal length of such a lens is 20 cm, find its power in new cartesian sign conventions.
- 298) Draw the following diagram, in which a ray of light is incident on a concave/convex mirror, on your answer sheet. Show the path of this ray, after reflection, in each case.

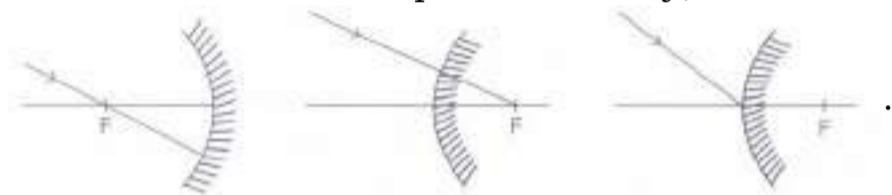

- 299) Draw a ray diagram to show the path of the reflected ray in each of the following cases. A ray of light incident on a convex mirror  
 (a) strikes at its pole making an angle from the principal axis.  
 (b) is directed towards its principal focus.  
 (c) is parallel to its principal axis.
- 300) Draw a ray diagram to show the path of light when it travels through glass slab.
- 301) To construct a ray diagram we use two rays of light which are so chosen that it is easy to determine their directions after reflection from the mirror. Choose these two rays and state the path of these rays after reflection from a concave mirror, Use these two rays to find the nature and position of the image of an object placed at a distance of 15 cm from a concave mirror of focal length 10 cm.
- 302) The absolute refractive indices of glass and water are  $\frac{4}{3}$  and  $\frac{3}{2}$  respectively. If the speed of light in glass is  $2 \times 10^8$  m/s, calculate the speed of light in  
 (i) vacuum,  
 (ii) water
- 303) A 6 cm tall object is placed perpendicular to the principal axis of a convex lens of focal length 15 cm. The distance of the object from the lens is 10 cm. Find the position, size and nature of the image formed, using the lens formula
- 304) A 4 cm tall object is placed perpendicular to the principal axis of a convex lens of focal length 24 cm. The distance of the object from the lens is 16 cm. Find the position, size and nature of the image formed, using the lens formula
- 305) A convex lens has a focal length of 10 cm. At what distance from the lens should the object be placed so that it gives a real and inverted image 20 cm away from the lens? What would be the size of the image formed if the object is 2 cm high? With the help of a ray diagram show the formation of the image by the lens in this case



- 306) The speed of light in air is  $3.0 \times 10^8$  m/s.  
 The speed of light in a transparent liquid is  $2.0 \times 10^8$  m/s.  
 A ray of light is incident on the surface of the liquid at an angle of incidence of  $40^\circ$ .  
 Calculate  
 (i) the refractive index of the liquid.  
 (ii) the angle of refraction in the liquid.  
 (iii) Draw two rays in the above diagram to show (how light reaches our eye from the object placed in water).

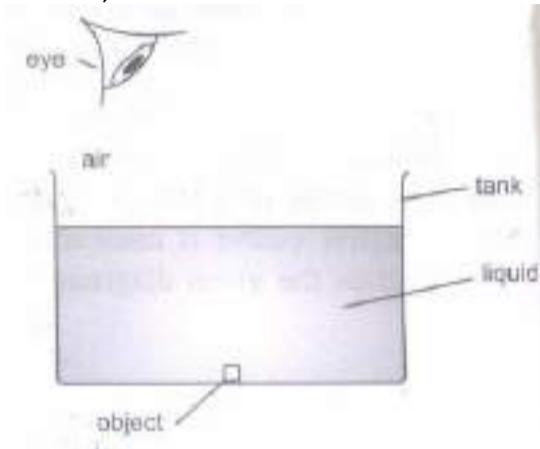

- 307) Draw the following diagram in your answer book and show the formation of image of the object AB with the help of suitable rays

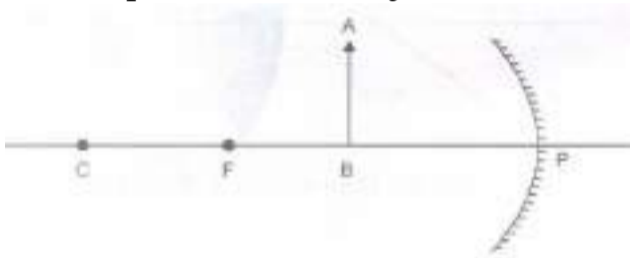

- 308) Draw ray diagrams to represent the nature, position and relative size of the image formed by a convex lens for the object placed:

- (a) At  $2F$   
 (b) Between  $F_1$  and the optical centre O of lens

- 309) (a) It is desired to obtain an erect image of an object using a concave mirror of focal length 20 cm.  
 (i) What should be the range of distance of the object from the mirror?  
 (ii) Will the image be bigger or smaller than the object?  
 (iii) Draw a ray diagram to show the image formation in this case.  
 (b) One-half of a convex lens of focal length 20 cm is covered with a black paper.  
 (i) Will the lens produce a complete image of the object?  
 (ii) Show the formation of image of an object placed at  $2F_1$  of such covered lens with the help of a ray diagram.  
 (iii) How will the intensity of the image formed by half-covered lens compare with non-covered lens?

- 310) An object of 2 cm high is placed at a distance of 64 cm from a white screen on placing a convex lens at a distance of 32 cm from the object it is found that a distant image of the object is formed on the screen. What is the focal length of the convex lens and size of the image formed on the screen? Draw a ray diagram to show the formation of the image in this position of the object with respect to the lens.

- 311) Redraw the given diagram and show the path of refracted ray.

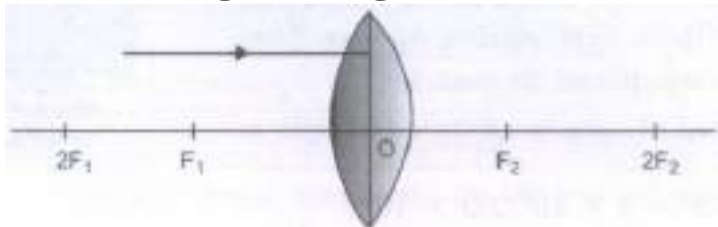

- 312) Give the laws of refraction of light.

- 313) Draw a ray diagram of image formed when an object is placed in front of convex lens

- (i) beyond  $2F$  and  
 (ii) between  $F$  and  $2F$

- 314) If the speed of light in water is  $2.25 \times 10^8$  m/s and the speed in vacuum is  $3 \times 10^8$  m/s. Calculate the refractive index of water.

- 315) Draw ray diagram in each of the following cases to show what happens after reflection to the incident ray when
- it is parallel to the principal axis and falling on a convex mirror.
  - it is falling on a concave mirror while passing through its principal focus.
  - it is coming oblique to the principal axis and falling on the pole of a convex mirror.
- 316) A child is standing in front of a magic mirror. She finds the image of her head bigger, the middle portion of her body of the same size and that of the legs smaller. Explain the construction of the magic mirror using different types of mirror. Also state the reasons in support of your answer.
- 317) Rohit wants to have an erect image of an object using a converging mirror of focal length 40 cm.
- Specify the range of distance where the object can be placed in front of the mirror. Give reason for your answer.
  - Will the image be bigger or smaller than the object?
  - Draw a ray diagram to show the image formation in this case.
- 318) (i) A security mirror used in a big showroom has radius of curvature 5 m. If a customer is standing at a distance of 20 m from the cash counter, find the position, nature and size of the image formed in the security mirror.
- (ii) Neha visited a dentist in his clinic. She observed that the dentist was holding an instrument fitted with a mirror. State the nature of this mirror and reason for its use in the instrument used by dentist.
- 319) (i) Water has refractive index 1.33 and alcohol has refractive index 1.36. Which of the two medium is optically denser? Give reason for your answer.
- (ii) Draw a ray diagram to show the path of a ray of light passing obliquely from water to alcohol.
- (iii) State the relationship between angle of incidence and angle of refraction in the above case.
- 320) Refractive index of water with respect to air is 1.33 and that of diamond is 2.42.
- In which medium does the light move faster, water or diamond?
  - What is the refractive index of diamond with respect to water?
- 321) A light ray enters from medium A to medium B as shown in the figure.

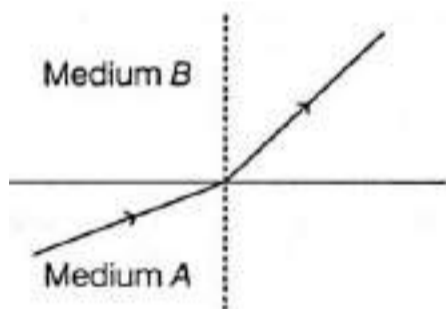

- Which one of the two media is denser w.r.t. other medium? Justify your answer.
- If the speed of light in medium A is  $v_a$  and in medium B is  $v_b$ , what is the refractive index of B with respect to A.

Or

A ray of light starting from diamond is incident on the interface separating diamond and water. Draw a labelled ray diagram to show the refraction of light in this case.

- Absolute refractive indices of diamond and water are 2.42 and 1.33, respectively. Find the value of refractive index of water W.r.t. diamond.

- 322) Manju has two convex lenses P and Q made of the same material as shown in the figure. She is looking at printed text on a page using lens P. She notices that when she slowly takes the lens away from the page, the text turns upside down when the lens crosses a distance of 10 cm from the page.
- (i) Which characteristic of lens P does the distance 10 cm signify?
- (ii) If Manju does the same with lens Q, at what distance will the inversion of the image happen-less than, equal to or more than 10 cm? Justify your answer.

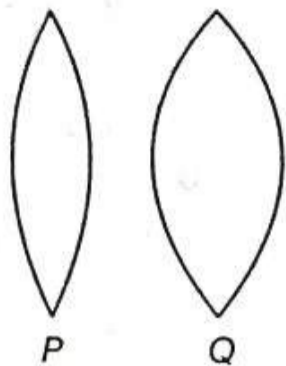

- 323) An object is kept at a distance of 1 m from a lens of power + 2 D.
- (a) Identify the type of lens.
- (b) Calculate its focal length and distance of the image formed.
- 324) Define the following terms in the context of a diverging lens.
- (a) Principal focus
- (b) Focal length
- Draw a labelled ray diagram to illustrate your answer.
- 325) A student has focused the image of an object of height 3 cm on a white screen using a concave mirror of focal length 12 cm. If the distance of the object from the mirror is 18 cm, find the values of the following.
- (a) Distance of the image from the mirror.
- (b) Height of the image.
- 326) An object of height  $h$  is kept at point P in front of a mirror as shown below. The height of the image produced is  $h'$ . In the diagram, F is the focus and C is the centre of curvature.

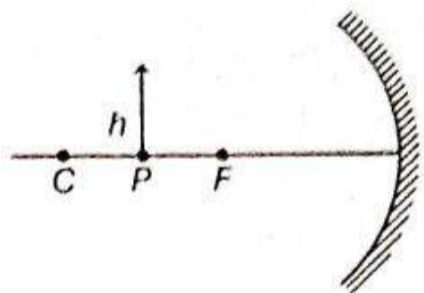

- (i) If the object is now moved to point C, will the height of the image now produced be less than, equal to, or greater than  $h$ ? Give a reason for your answer.
- (ii) If the focal length of the mirror is 20 cm and the distance between points P and C is 10 cm, determine the distance between the images produced when the object is kept at P and C.
- 327) An object is placed at a distance of 60 cm from a concave lens of focal length 30 cm.
- (i) Use lens formula to find the distance of the image from the lens.
- (ii) List four characteristics of the image (nature, position, size, erect/inverted) formed by the lens in this case.
- (iii) Draw the ray diagram to justify your answer of part (ii).
- 328) (i) An object of 5 cm height is placed at a distance of 20 cm from the optical centre of a concave lens of focal length 18 cm. Calculate (a) image distance and (b) the magnification in this case.
- (ii) (a) Compare the values of magnification obtained by a concave lens and a convex lens when both the lenses form virtual images.
- Or
- (b) A convex lens can form a (I) real, inverted and magnified image as well as (II) virtual, erect and magnified image of an object. If the focal length of the lens is 10 cm, what should be the range of the object distance in both cases? Draw ray diagrams to justify your answer.

- 329) Draw the ray diagram in your answer book and show the formation of Image of object AB with suitable rays. Mention the position and nature of image.

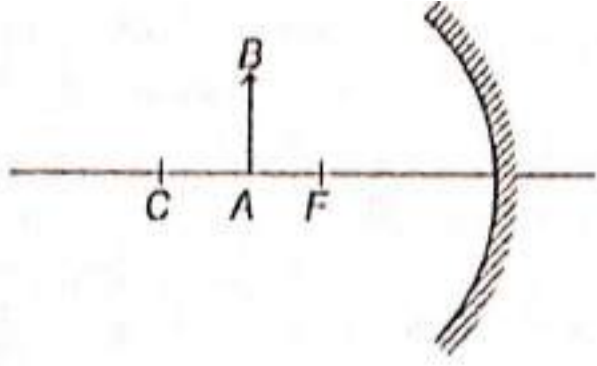

Case Study Questions

23 x 4 = 92

- 330) The curved surface of a spoon can be considered as a spherical mirror. A highly smooth polished surface is called mirror. The mirror whose reflecting surface is curved inwards or outwards is called a spherical mirror. Inner part works as a concave mirror and the outer bulging part acts as a convex mirror. The center of the reflecting surface of a mirror is called pole and the radius of the sphere of which the mirror is formed is called radius of curvature.

(i) When a concave mirror is held towards the sun and its sharp image is formed on a piece of carbon paper for some time, a hole is burnt in the carbon paper. What is the name given to the distance between the mirror and carbon paper?

- (a) Radius of curvature      (b) Focal length  
(c) Principal focus      (d) Principal axis

(ii) The distance between pole and focal point of a spherical mirror is equal to the distance between

- (a) pole and center of curvature      (b) focus point and center of curvature  
(c) pole and object      (d) object and image

(iii) The focal length of a mirror is 15 cm. The radius of curvature is

- (a) 15 cm      (b) 30 cm  
(c) 45 cm      (d) 60 cm

(iv) The normal at any point on the mirror passes through

- (a) focus      (b) pole  
(c) center of curvature      (d) any point

(v) In a convex spherical mirror, reflection of light takes place at

- (a) a flat surface      (b) a bent-in surface  
(c) a bulging-out surface      (d) an uneven surface

- 331) The spherical mirror forms different types of images when the object is placed at different locations. When the image is formed on screen, the image is real and when the image does not form on screen, the image is virtual. When the two reflected rays meet actually, the image is real and when they appear to meet, the image is virtual.
- A concave mirror always forms a real and inverted image for different positions of the object. But if the object is placed between the focus and pole, the image formed is virtual and erect.
- A convex mirror always forms a virtual, erect and diminished image. A concave mirror is used as doctor's head mirror to focus light on body parts like eyes, ears, nose etc., to be examined because it can form erect and magnified image of the object. The convex mirror is used as a rear view mirrors in automobiles because it can form an small and erect image of an object.
- (i) When an object is placed at the centre of curvature of a concave mirror, the image formed is  
**(a) larger than the object**      **(b) smaller than the object**  
**(c) same size as that of the object**      **(d) highly enlarged.**
- (ii) No matter how far you stand from a mirror, your image appears erect. The mirror is likely to be  
**(a) plane**      **(b) concave**  
**(c) convex**      **(d) either plane or convex.**
- (iii) A child is standing in front of a magic mirror. She finds the image of her head bigger, the middle portion of her body of the same size and that of the legs smaller. The following is the order of combinations for the magic mirror from the top.  
**(a) Plane, concave and concave**      **(b) Convex, concave and plane**  
**(c) Concave, plane and convex**      **(d) Convex, plane and concave**
- (iv) To get an image larger than the object, one can use  
**(a) convex mirror but not a concave mirror**  
**(b) a concave mirror but not a convex mirror**  
**(c) either a convex mirror or a concave mirror**  
**(d) a plane mirror.**
- (v) A convex mirror has wider field of view because  
**(a) the image formed is much smaller than the object and large number of images can be seen**  
**(b) the image formed is much closer to the mirror**  
**(c) both (a) and (b)**  
**(d) none of these.**

332) The relation between distance of an object from the mirror ( $u$ ), distance of image from the mirror ( $v$ ) and the focal length ( $F$ ) is called mirror formula. This formula is valid in all situations for all spherical mirrors for all positions of the object. The size of image formed by a spherical mirror depends on the position of the object from the mirror. The image formed by a spherical mirror can be bigger than the object, equal to the object or smaller than the object. The size of the image relative to the object is given by the linear magnification ( $m$ ). Thus, the magnification is given by the ratio of height of image to the height of object. If magnification is negative, image is real and if it is positive, image is virtual.

(i) What is the position of an image when an object is placed at a distance of 20 cm from a concave mirror of focal length 20 cm?

- (a) 5 cm            (b) 20 cm  
 (c) 10 cm        (d) infinity

(ii) Which of the following ray diagrams is correct for the ray of light incident on a concave mirror as shown in figure?



(a) Figure A



(b) Figure B



(c) Figure C



(d) Figure D

(iii) If the magnification of an image is -2, the characteristic of image will be

- (a) real and inverted      (b) virtual and enlarged  
 (c) virtual and inverted    (d) real and small

(iv) The mirror formula holds for

- (a) concave mirror        (b) convex mirror  
 (c) plane mirror        (d) all of these

(v) A parallel beam of light is made to fall on a concave mirror. An image is formed at a distance of 7.5 cm from the mirror. The focal length of the mirror is

- (a) 15 cm            (b) 7.5 cm  
 (c) 3.75 cm        (d) 10 cm

- 333) When the rays of light travels from one transparent medium to another, the path of light is deviated. This phenomena is called refraction of light. The bending of light depends on the optical density of medium through which the light pass.

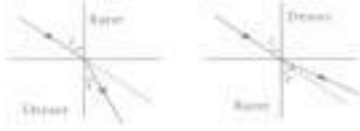

The speed of light varies from medium to medium. A medium in which the speed of light is more is optically rarer medium whereas in which the speed of light is less is optically denser medium. Whenever light goes from one medium to another, the frequency of light does not change however, speed and wavelength change. It concluded that change in speed of light is the basic cause of refraction.

(i) When light travels from air to glass, the ray of light bends

- (a) towards the normal**      **(b) away from normal**  
**(c) anywhere**      **(d) none of these**

(ii) A ray of light passes from a medium A to another medium B. No bending of light occurs if the ray of light hits the boundary of medium B at an angle of

- (a) 0°**      **(b) 45°**  
**(c) 90°**      **(d) 120°**

(iii) When light passes from one medium to another, the frequency of light

- (a) increases**      **(b) decreases**  
**(c) remains same** **(d) none of these**

(iv) When light passes from glass to water, the speed of light

- (a) increases** **(b) decreases**  
**(c) remains same**      **(d) first increases then decrease**

(v) The bottom of pool filled with water appears to be \_\_\_\_\_ due to refraction of light

- (a) shallower**      **(b) deeper**  
**(c) at same depth**      **(d) empty**

- 334) The refraction of light on going from one medium to another takes place according to two laws which are known as the laws of refraction of light. These laws are

1. The ratio of sine of angle of incidence to the sine of angle of refraction is always constant for the pair of media in contact.

$$\frac{\sin i}{\sin r} = \mu = \text{constant}$$

This constant is called refractive index of the second medium with respect to the first medium.

Refractive index is also defined as the ratio of speed of light in vacuum to the speed of light in medium.

2. The incident ray, refracted ray and normal all lie in the same plane.

This law is called Snell's law of refraction.

(i) When light travels from air to glass,

- (a) angle of incidence > angle of refraction**  
**(b) angle of incidence < angle of refraction**  
**(c) angle of incidence = angle of refraction**  
**(d) can't say**

(ii) When light travels from air to medium, the angle of incidence is 45° and angle of refraction is 30°.

The refractive index of second medium with respect to the first medium is

- (a) 1.41**      **(b) 1.50**  
**(c) 1.23**      **(d) 1**

(iii) In which medium, the speed of light is minimum?

- (a) Air**      **(b) Glass**  
**(c) Water**      **(d) Diamond**

(iv) If the refractive index of glass is 1.5 and speed of light in air is  $3 \times 10^8$  m/s. The speed of light in glass is

- (a)  $2 \times 10^8$  m/s**      **(b)  $2.9 \times 10^8$  m/s**  
**(c)  $4.5 \times 10^8$  m/s** **(d)  $3 \times 10^8$  m/s**

(v) Refractive index of a with respect to b is 2. Find the refractive index of b with respect to a.

- (a) 0.4**      **(b) 0.5**  
**(c) 0.25**      **(d) 2.**

- 335) A lens is a piece of any transparent material bounded by two curved surfaces. There are two types of lenses convex lens and concave lens.

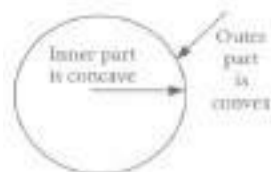

Convex lens is made up of a transparent medium bounded by two spherical surfaces such that thicker at the middle and thinner at the edges. Concave lens is also made up of a transparent medium such that thicker at the edge and thinner at the middle. The mid point of the lens is called optical centre. A point on the principal axis, where the incident parallel rays meet or appears to come out after refraction is called focus.

A convex lens converges a parallel beam of light to other side whereas concave lens spreads out.

- (i) Which of the following lenses would you prefer to use while reading small letters found in dictionary?

**(a) A convex lens of focal length 50 cm**

**(b) A concave lens of focal length 50 cm**

**(c) A convex lens of focal length 5 cm**

**(d) A concave lens of focal length 5 cm**

- (ii) Which type of lenses are shown in given figure (i) and (ii).

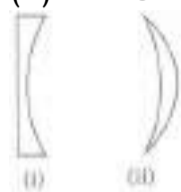

**(a) Plano concave, concavo convex**

**(b) Plano convex, convexo concave**

**(c) Double concave, concave convex**

**(d) Convexo concave, double convex**

- (iii) A small bulb is placed at the focal point of a converging lens. When the bulb is switched on, the lens produces

**(a) a convergent beam of light**

**(b) a divergent beam of light**

**(c) a parallel beam of light**

**(d) a patch of coloured light**

- (iv) The part of lens through which the refraction takes place is called

**(a) aperture**      **(b) centre of curvature**

**(c) principal axis**      **(d) focus**

- (v) A water drop acts as a

**(a) convex lens**      **(b) concave lens**

**(c) double concave lens**      **(d) none of these**



- 336) The lenses forms different types of images when object placed at different locations. When a ray is incident parallel to the principal axis, then after refraction, it passes through the focus or appears to come from the focus. When a ray goes through the optical centre of the lens, it passes without any deviation.
- If the object is placed between focus and optical center of the convex lens, erect and magnified image is formed. As the object is brought closer to the convex lens from infinity to focus, the image moves away from the convex lens from focus to infinity. Also the size of image goes on increasing and the image is always real and inverted. A concave lens always gives a virtual, erect and diminished image irrespective to the position of the object.
- (i) The location of image formed by a convex lens when the object is placed at infinity is  
**(a) at focus**      **(b) at 2F**  
**(c) at optical center**      **(d) between F and 2F**
- (ii) When the object is placed at the focus of concave lens, the image formed is  
**(a) real and smaller**      **(b) virtual and inverted**  
**(c) virtual and smaller**      **(d) real and erect**
- (iii) The size of image formed by a convex lens when the object is placed at the focus of convex lens is  
**(a) small**      **(b) point in size**  
**(c) highly magnified**      **(d) same as that of object**
- (iv) When the object is placed at 2F in front of convex lens, the location of image is  
**(a) at F**      **(b) at 2 F on the other side**  
**(c) at infinity**      **(d) between F and optical center**
- 337) The relationship between the distance of object from the lens (u), distance of image from the lens (v) and the focal length (f) of the lens is called lens formula. It can be written as  $\frac{1}{f} = \frac{1}{v} - \frac{1}{u}$
- The size of image formed by a lens depends on the position of the object from the lens. A lens of short focal length has more power whereas a lens of long focal length has less power. When the lens is convex, the power is positive and for concave lens, the power is negative.
- The magnification produced by a lens is the ratio of height of image to the height of object as the size of the image relative to the object is given by linear magnification (m).
- When, m is negative, image formed is real and when m is positive, image formed is virtual. If  $m < 1$ , size of image is smaller than the object. If  $m > 1$ , size of image is larger than the object.
- (i) An object 4 cm in height is placed at a distance of 10 cm from a convex lens of focal length 20 cm. The position of image is  
**(a) - 20 cm**      **(b) 20 cm**  
**(c) -10 cm**      **(d) 10 cm**
- (ii) In the above question, the size of image is  
**(a) 16 cm**      **(b) 8 cm**  
**(c) 4 cm**      **(d) 2 cm**
- (iii) An object is placed 50 cm from a concave lens and produces a virtual image at a distance of 10 cm in front of lens. The focal length of lens is  
**(a) - 25 cm**      **(b) -12.5 cm**  
**(c) 12.5 cm**      **(d) 10 cm**
- (iv) A convex lens forms an image of magnification -2 of the height of image is 6 cm, the height of object is  
**(a) 6 cm**      **(b) 4 cm**  
**(c) 3 cm**      **(d) 2 cm**
- (v) A concave lens of focal length 5 cm, the power of lens is  
**(a) 20D**      **(b) -20D**  
**(c) 90D**      **(d) -5 D**

- 338) Nazima is fly fishing in a stream. The tip of her fishing rod is 1.8 m above the surface of the water and the fly at the end of the string rests on the water 3.6 m away and 2.4 m from a point directly under the tip of the rod. She is pulling the string at the rate of 5 cm per second. Nazima's friend observe her position and draw a rough sketch by using A, B, C and D positions of tip, point directly under the tip of the rod, fish and Nazima's position (see the below figure). Assuming that her string (from the tip of her rod to the fly) is taut, answer the following questions:

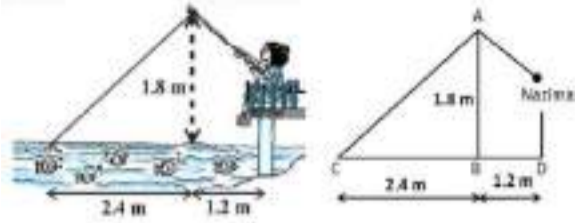

- (i) What is the length AC?  
 (a) 2 m (b) 3 m (c) 4 m (d) 5 m
- (ii) What is the length of string pulled in 12 seconds?  
 (a) 6 m (b) 0.3 m (c) 0.6 m (d) 3 m
- (iii) What is the length of string after 12 seconds?

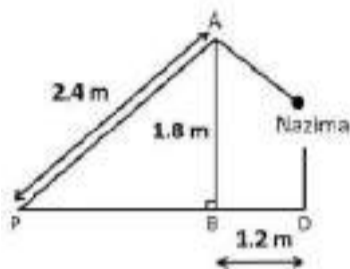

- (a) 2.4 m (b) 2.7 m (c) 2 m (d) 2.2 m
- (iv) What will be the horizontal distance of the fly from her after 12 seconds?  
 (a) 2.7 m (b) 2.78 m (c) 2.58 m (d) 2.2 m
- (v) The given problem is based on which concept?  
 (a) Triangles geometry (b) Co-ordinate geometry (c) Height and Distance (d) None of these

- 339) Junk food is unhealthy food that is high in calories from sugar or fat, with little dietary fiber, protein, vitamins, minerals, or other important forms of nutritional value. A sample of few students have taken. If  $\alpha$  be the number of students who take junk food,  $\beta$  be the number of students who take healthy food such that  $\alpha > \beta$  and  $\alpha$  and  $\beta$  are the zeroes of the quadratic polynomial  $f(x) = x^2 - 7x + 10$ , then answer the following questions:



- (i) Name the type of expression of the polynomial in the above statement?  
 (a) quadratic (b) cubic (c) linear (d) bi-quadratic
- (ii) Find the number of students who take junk food.  
 (a) 5 (b) 2 (c) 7 (d) None of these
- (iii) Find the number of students who take healthy food.  
 (a) 5 (b) 2 (c) 7 (d) None of these
- (iv) Find the quadratic polynomial whose zeros are -3 and -4.  
 (a)  $x^2 + 4x + 2$  (b)  $x^2 - x - 12$   
 (c)  $x^2 - 7x + 12$  (d) None of these
- (v) If one zero of the polynomial  $x^2 - 5x + 6$  is 2 then find the other zero.  
 (a) 6 (b) -6 (c) 2 (d) None of these

- 340) Mathematics teacher of a school took her 10th standard students to show Red fort. It was a part of their Educational trip. The teacher had interest in history as well. She narrated the facts of Red fort to students. Then the teacher said in this monument one can find combination of solid figures. There are 2 pillars which are cylindrical in shape. Also 2 domes at the corners which are hemispherical. 7 smaller domes at the centre. Flag hoisting ceremony on Independence Day takes place near these domes.



**(i) How much cloth material will be required to cover 2 big domes each of radius 2.5 metres?**

**(Take  $\pi = 22/7$ )**

(a)  $75 \text{ m}^2$  (b)  $78.57 \text{ m}^2$  (c)  $87.47 \text{ m}^2$  (d)  $25.8 \text{ m}^2$

**(ii) Write the formula to find the volume of a cylindrical pillar :**

(a)  $\pi r^2 h$  (b)  $\pi r l$  (c)  $\pi r (l+r)$  (d)  $2\pi r$

**(iii) Find the lateral surface area of two pillars if height of the pillar is 7 m and radius of the base is 1.4m.**

(a)  $112.3 \text{ cm}^2$  (b)  $123.2 \text{ m}^2$  (c)  $90 \text{ m}^2$  (d)  $345.2 \text{ cm}^2$

**(iv) How much is the volume of a hemisphere if the radius of the base is 3.5 m?**

(a)  $85.9 \text{ m}^3$  (b)  $80 \text{ m}^3$  (c)  $98 \text{ m}^3$  (d)  $89.83 \text{ m}^3$

**(v) What is the ratio of sum of volumes of two hemispheres of radius 1 cm each to the volume of a sphere of radius 2 cm?**

(a) 1:1 (b) 1:8 (c) 8:1 (d) 1:16

- 341) On one day, a poor girl of height 90 cm is looking for a lamp-post for completing her homework as in her area power is not there and she finds the same at some distance away from her home. After completing the homework, she is walking away from the base of a lamp-post at a speed of 1.2 m/s. The lamp is 3.6 m above the ground (see below figure).

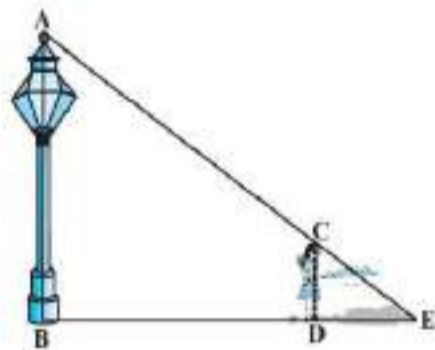

**(i) Find her distance from the base of the lamp post.**

(a) 1.2 m (b) 3.6 m (c) 4.8 m (d) none of these

**(ii) Find the correct similarity criteria applicable for triangles ABE and CDE.**

(a) AA (b) SAS (c) SSS (d) AAS

**(iii) Find the length of her shadow after 4 seconds.**

(a) 1.2 m (b) 3.6 m (c) 4.8 m (d) none of these

**(iv) Sides of two similar triangles are in the ratio 9:16. Find the ratio of Corresponding areas of these triangles.**

(a) 9:16 (b) 3:4 (c) 81:256 (d) 18:32

**(v) Find the ratio AC:CE.**

(a) 1:3 (b) 3:1 (c) 1:4 (d) 4:1

- 342) In the below given layout, the design and measurements has been made such that area of two bedrooms and Kitchen together is 95 sq. m.

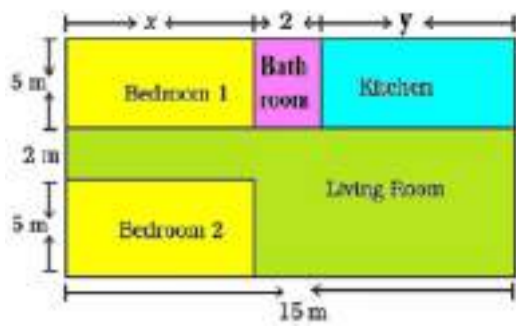

- (i) The area of two bedrooms and kitchen are respectively equal to  
 (a)  $5x, 5y$  (b)  $10x, 5y$  (c)  $5x, 10y$  (d)  $x, y$
- (ii) Find the length of the outer boundary of the layout.  
 (a) 27 m (b) 15 m (c) 50 m (d) 54 m
- (iii) Find the area of each bedroom.  
 (a) 30 sq. m (b) 35 sq. m  
 (c) 65 sq. m (d) 42 sq. m
- (iv) Find the area of living room in the layout.  
 (a) 30 sq. m (b) 35 sq. m  
 (c) 75 sq. m (d) 65 sq. m
- (v) Find the cost of laying tiles in Kitchen at the rate of Rs. 50 per sq. m  
 (a) Rs. 1500 (b) Rs. 2000 (c) Rs. 1750 (d) Rs. 3000

- 343) A student made a wooden pen stand which is in the shape of a cuboid with four conical depressions to hold pens. The dimensions of the cuboid are 15 cm by 10 cm by 3.5 cm. The radius of each of the depressions is 0.5 cm and the depth is 1.4 cm. Find the volume of wood in the entire stand (see the below figure)

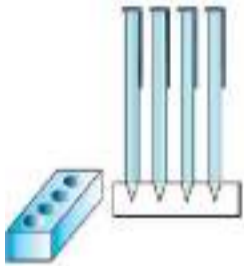

- (i) What is the volume of cuboid?  
 (a)  $525 \text{ cm}^3$  (b)  $225 \text{ cm}^3$  (iii)  $552 \text{ cm}^3$  (d)  $255 \text{ cm}^3$
- (ii) What is the volume of cone?  
 (a)  $\frac{11}{3} \text{ cm}^3$  (b)  $\frac{11}{30} \text{ cm}^3$  (c)  $\frac{3}{11} \text{ cm}^3$  (d)  $\frac{30}{11} \text{ cm}^3$
- (iii) What is the total volume of conical depressions?  
 (a)  $1.74 \text{ cm}^3$  (b)  $1.44 \text{ cm}^3$  (c)  $1.47 \text{ cm}^3$  (d)  $1.77 \text{ cm}^3$
- (iv) What is the volume of wood in the entire stand?  
 (a) 522.35 (b) 532.53 (c) 523.35 (d) 523.53  
 $\text{cm}^3$   $\text{cm}^3$   $\text{cm}^3$   $\text{cm}^3$
- (v) The given problem is based on which mathematical concept?  
 (a) Triangle (b) Surface Areas & volumes  
 (c) Height & Distances (d) None of these

- 344) In a potato race, a bucket is placed at the starting point, which is 4 m from the first potato, and the other potatoes are placed 3 m apart in a straight line. There are ten potatoes in the line (see below figure).  
A competitor starts from the bucket, picks up the nearest potato, runs back with it, drops it in the bucket, runs back to pick up the next potato, runs to the bucket to drop it in, and she continues in the same way until all the potatoes are in the bucket.



**(i) What is the distance covered by the competitor in first potato?**

- (a) 10 m      (b) 8 m      (c) 12 m      (d) 14m

**(ii) What is the distance covered by the competitor in second potato?**

- (a) 14 m      (b) 12 m      (c) 10 m      (d) 8 m

**(iii) What is the distance covered by the competitor in fourth potato?**

- (a) 22 m      (b) 24 m      (c) 26 m      (d) 28 m

**(iv) What is the total distance covered by the competitor in first and second potato?**

- (a) 22 m      (b) 24 m      (c) 26 m      (d) 30 m

**(v) If the A.P. 8, 14, 20, ..., then find the common difference.**

- (a) 4          (b) 8          (c) 12          (d) 6

- 345) Ruby and Rita are best friends. They are staying in the same colony. Both are studying in the same class and in the same school. During Winter vacation Ruby visited Rita's house to play Ludo. They decided to play Ludo with 2 dice.



**(i) To win a game, Ruby wanted a total of 7. What is the probability of winning a game by ruby?**

- (a)  $\frac{1}{6}$       (b)  $\frac{7}{12}$       (c)  $\frac{5}{18}$       (d)  $\frac{1}{9}$

**(ii) To win a game, Rita wanted 8 as the sum. What is the probability of winning a game by Rita?**

- (a)  $\frac{1}{12}$       (b)  $\frac{7}{36}$       (c)  $\frac{5}{36}$       (d)  $\frac{1}{4}$

**(iii) What is the probability that the sum of the number on the both the dice is divisible by 4 or 6?**

- (a)  $\frac{7}{18}$       (b)  $\frac{7}{15}$       (c)  $\frac{5}{18}$       (d)  $\frac{2}{9}$

**(iv) The probability of getting a total of at least 10 is:**

- (a)  $\frac{1}{6}$       (b)  $\frac{1}{3}$       (c)  $\frac{2}{3}$       (d)  $\frac{1}{4}$

**(v) The probability that 5 will come up at least in 1 die is:**

- (a)  $\frac{7}{36}$       (b)  $\frac{11}{36}$       (c)  $\frac{25}{36}$       (d)  $\frac{2}{9}$

- 346) In a school, Class X B and C students appeared for Sunday Sample paper test 05 and marks obtained out of 80 are formulated in a table as follows:



Marks	Number of student
Less than 10	8
Less than 20	20
Less than 30	30
Less than 40	50
Less than 50	60
Less than 60	70
Less than 70	75
Less than 80	80

(i) How many students secured less than 40 marks?

- (a) 50      (b) 40      (c) 60      (d) 30

(ii) What is the upper limit of modal class?

Marks	Number of student	cf
0-10	8	8
10-20	12	20
20-30	10	30
30-40	20	50
40-50	10	60
50-60	10	70
60-70	5	75
70-80	5	80

- (a) 20      (b) 30      (c) 40      (d) 50

(iii) The median class is :

- (a) 10-20    (b) 20-30    (c) 30-40    (d) 40-50

(iv) The mean marks of the students is :

- (a) 35.8      (b) 35.9      (c) 36      (d) 36.5

(e) Class mark of the class preceding the modal class is :

Marks	x	f	fx
0-10	5	8	40
10-20	15	12	180
20-30	25	10	250
30-40	35	20	700
40-50	45	10	450
50-60	55	10	550
60-70	65	5	325
70-80	75	5	375
Total		80	2870

- (a) 35      (b) 30      (c) 25      (d) 45

- 347) A student took concave mirrors of different focal lengths and performed the experiment to see the Image formation by placing an object at different distances with these mirrors as shown in the following table.

Case No.	Object-distance	Focal length
I	45 cm	20 cm
II	30 cm	15 cm
III	20 cm	30 cm

Now, answer the following questions :

- (i) List two properties of the image formed in Case I.  
(ii) In which one of the cases given in the table, the mirror will form real image of same size and why?  
(iii) Name the type of mirror used by dentists. Give reason why do they use such type of mirrors.

Or Look at the table and identify the situation (object distance and focal length) which resembles the situation in which concave mirrors are used as shaving mirrors? Draw a ray diagram to show the image formation in the case.

- 348) Hold a concave mirror in your hand and direct its reflecting surface towards the sun. Direct the light reflected by the mirror on to a white card-board held close to the mirror. Move the card-board back and forth gradually until you find a bright, sharp spot of light on the board. This spot of light is the image of the sun on the sheet of paper, which is also termed as "Principal Focus" of the concave mirror.

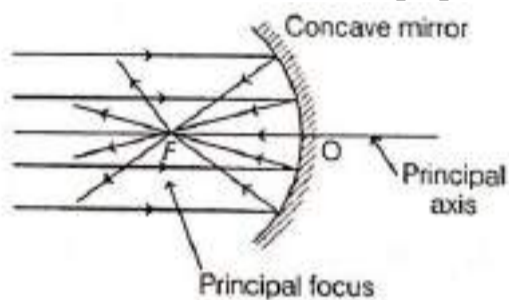

- (i) List two applications of concave mirror.  
(ii) If the distance between the mirror and the principal focus is 15 cm, find the radius of Curvature of the mirror.  
(iii) Draw a ray diagram to show the type of image formed when an object is placed between pole and focus of a concave mirror.

Or

An object 10 cm in size is placed at 100 cm in front of a concave mirror. If its image is formed at the same point where the object is located, find

- (a) focal length of the mirror, and  
(b) magnification of the image formed with sign as per New Cartesian sign convention.

- 349) The following images are that of a specialized slide projector. Slides are small transparencies mounted in sturdy frames ideally suited to magnification and projection, since they have a very high resolution and a high image quality. There is a tray where the slides are to be put into a particular orientation so that the viewers can see the enlarged erect images of the transparent slides. This means that the slides will have to be inserted upside down in the projector tray. To show her students the images of insects that she investigated In the lab, Mrs. Iyer brought a slide projector. Her slide projector produced a 500 times enlarged and Inverted image of a slide on a screen 10 m away.

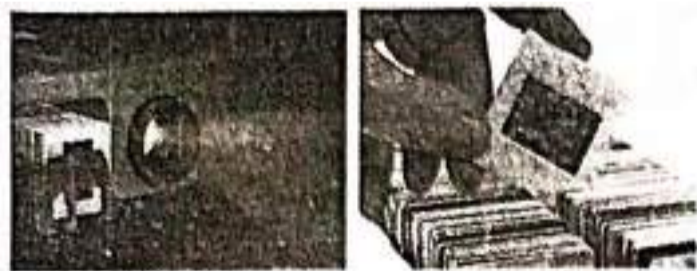

- (i) Based on the text and data given in the above paragraph, what kind of lens must the slide projector have?  
(ii) If  $v$  is the symbol used for image distance and  $u$  for object distance, then with one reason state what will be the sign for  $\frac{v}{u}$  in the given case?  
(iii) A slide projector has a convex lens with a focal length of 20 cm. The slide is placed upside down 21 cm from the lens. How far away should the screen be placed from the slide projector's lens so that the slide is in focus?

Or

When a slide is placed 15 cm behind the lens in the projector, an image is formed 3 m in front of the lens. If the focal length of the lens is 14 cm, draw a ray diagram to show image formation. (not to scale)

350) The image below shows the design of a refracting telescope.

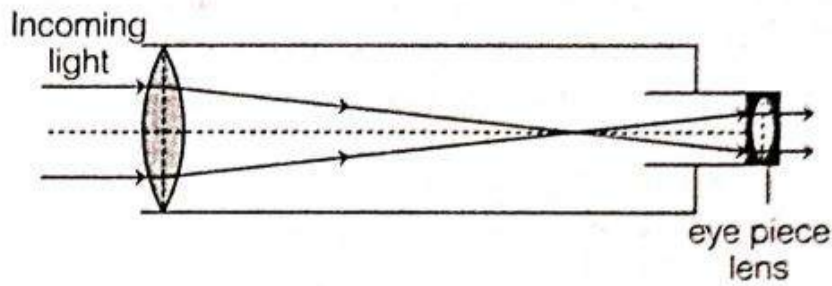

When light passes through a prism, it splits into different colours and dispersion takes place. The same thing happens with a lens but to a much lesser degree. This is called chromatic aberration and causes the different colours of light to focus at different points. To overcome this problem, the reflecting telescope was invented. One design of the reflecting telescope is shown below.

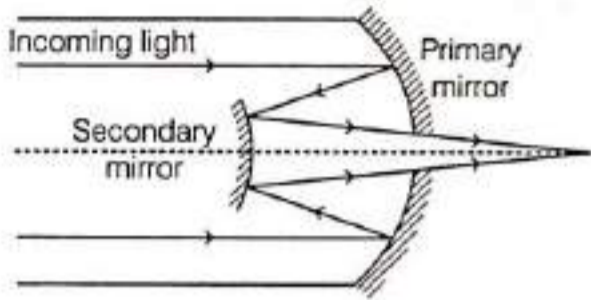

- (i) Why is there no chromatic aberration in reflecting telescopes?
- (ii) One of the critical factors affecting a telescope is the amount of light it can gather. The more light a telescope can gather, the better the image it produces. What can be done to the lens to increase the amount of light a telescope gathers?
- (iii) The light that reaches the telescopes comes from very far away celestial objects. Draw a ray diagram to show what happens when light from a far away object falls on a convex lens and a concave lens.

Or

The light that reaches the telescopes comes from very far away celestial objects. Draw a ray diagram to show what happens when light from a far away object falls on a convex mirror and a concave mirror.

351) Many optical instruments consist of a number of lenses. They are combined to increase the magnification and sharpness of the image. The net power (P) of the lenses placed in contact is given by the algebraic sum of the powers of the individual lenses  $P_1, P_2, P_3, \dots$  as

$$P = P_1 + P_2 + P_3 \dots$$

This is also termed as the simple additive property of the power of lens, widely used to design lens systems of cameras, microscopes and telescopes. These lens systems can have a combination of convex lenses and also concave lenses.

- (i) What is the nature (convergent/divergent) of the combination of a convex lens of power + 4D and a concave lens of power - 2D?
- (ii) Calculate the focal length of a lens of power 2.5D.
- (iii) Draw a ray diagram to show the nature and position of an image formed by a convex lens of power + 0.1D, when an object is placed at a distance, of 20 cm from its optical centre.

Or

How is a virtual image formed by a convex lens different from that formed by a concave lens?

Under what conditions do a convex and a concave lens form virtual images?



- 352) Sumati wanted to see the stars of the night sky. She knows that she needs a telescope to see those distant stars. She finds out that the telescopes, which are made of lenses, are called refracting telescopes and the ones which are made of mirrors are called reflecting telescopes.

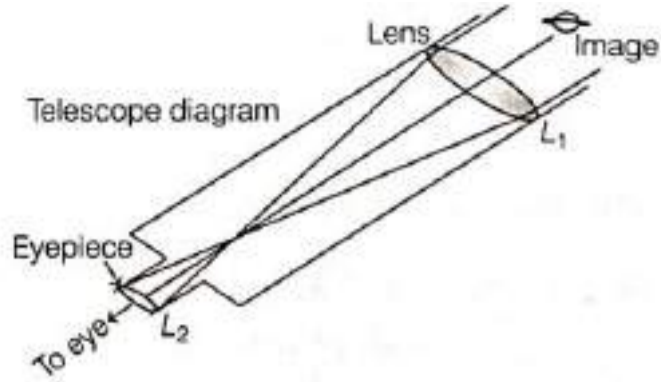

So, she decided to make a refracting telescope. She bought two lenses,  $L_1$  and  $L_2$  out of which  $L_1$  was bigger and  $L_2$  was smaller. The larger lens gathers and bends the light, while the smaller lens magnifies the Image. Big, thick lenses are more powerful. So to see far away, she needed a big powerful lens. Unfortunately, she realised that a big lens is very heavy.

Heavy lenses are hard to make and difficult to hold in the right place. Also, since the light is passing through the lens, the surface of the lens has to be extremely smooth. Any flaws the lens will change the image. It would be like looking through a dirty window.

(i) Based on the diagram shown, what kind of lenses would Sumati need to make the telescope?

- (a) Concave lenses (b) Convex lenses  
(c) Bi-focal lenses (d) Flat lenses

(ii) If the power of the lenses  $L_1$  and  $L_2$  are in the ratio of 4 : 1, what would be the ratio of the focal length of  $L_1$  and  $L_2$ ?

- (a) 4 : 1 (b) 1 : 4 (c) 2 : 1 (d) 1 : 1

(iii) What is the formula for magnification obtained with a lens?

- (a) Ratio of height of image to height of object  
(b) Double the focal length  
(c) Inverse of the radius of curvature  
(d) Inverse of the object distance

(iv) Sumati did some preliminary experiment with the lenses and found out that the magnification of the eyepiece ( $L_2$ ) is 3. If in her experiment with  $L_2$  she found an image at 24 cm from the lens, at what distance did she put the object?

- (a) 72 cm (b) 12 cm (c) 8 cm (d) 6 cm

Or

Sumati bought not-so-thick lenses for the telescope and polished them. What advantages, if any, would she have with her choice of lenses?

- (a) She will not have any advantage as even thicker lenses would give clearer images.  
(b) Thicker lenses would have made the telescope easier to handle.  
(c) Not-so-thick lenses would not make the telescope very heavy and also allow considerable amount of light to pass.  
(d) Not-so-thick lenses will give her more magnification.

5 Marks

77 x 5 = 385

- 353) A convex lens forms a real and inverted image of a needle at a distance of 50 cm from it. Where is the needle placed in front of the convex lens, if the image is equal to the size of object? Also, find the power of the lens.

- 354) Find out from table given below, the medium having highest optical density. Also, find the medium with lowest optical density.

**Absolute Refractive Index of Some Material Media**

Material Medium	Refractive Index	Material Medium	Refractive Index
Air	1.0003	Canada Balsam	1.53
Ice	1.31	Rock salt	1.54
Water	1.33	Carbon disulphide	1.63
Alcohol	1.36	Dense flint glass	1.65
Kerosene	1.44	Ruby	1.71
Fused quartz	1.46	Sapphire	1.77
Turpentine oil	1.47	Diamond	2.42
Benzene	1.50		
Crown glass	1.52		

- 355) We wish to obtain an erect image of an object, using a concave mirror of focal length 15 cm. What should be the range of distance of the object from the mirror? What is the nature of image? Is the image larger or smaller than the object? Draw a ray diagram to show the image formation in this case.
- 356) Name the type of mirror used in following situations.  
 (a) Headlight of car  
 (b) Side/ rear view mirror of a vehicle  
 (c) Solar furnace  
 Support your answer with reason.
- 357) One - half of a convex lens is covered with a black paper. Will this lens produce a complete image of the object? Verify your answer experimentally. Explain your observations.
- 358) An object 5 cm in length is held 25 cm away from a converging lens of focal length 10 cm. Draw the ray diagram and find the position, size and the nature of the image formed.
- 359) A concave lens of focal length 15 cm forms an image 10 cm from the lens. How far is the object placed from the lens? Draw the ray diagram.
- 360) An object is placed at a distance of 10 cm from a convex mirror of focal length 15 cm. Find the position and nature of the image.
- 361) An object 5.0 cm in length is placed at a distance of 20 cm in front of a convex mirror of radius of curvature 30 cm. Find the position of the image, its nature and size.
- 362) An object of size 7.0 cm is placed at 27 cm in front of a concave mirror of focal length 18 cm. At what distance from the mirror should a screen be placed, so that a sharp focussed image can be obtained? Find the size and the nature of the image.
- 363) You are given kerosene, turpentine and water. In which of these does light travel fastest?
- 364) A convex mirror used for rear-view on an automobile has a radius of curvature of 3.00 m. If a bus is located at 5.00 m from this mirror, find the position, nature and size of the image.
- 365) An object, 4.0 cm in size, is placed at 25.0 cm in front of a concave mirror of focal length 15.0 cm. At what distance from the mirror should a screen be placed in order to obtain a sharp image? Find the nature and the size of the image.
- 366) A concave lens has focal length of 15 cm. At what distance should the object from the lens be placed so that it forms an image at 10 cm from the lens? Also, find the magnification produced by the lens.

- 367) A 2.0 cm tall object is placed perpendicular to the principal axis of a convex lens of focal length 10 cm. The distance of the object from the lens is 15 cm. Find the nature, position and size of the image. Also find its magnification.
- 368) Write laws of refraction. Explain the same with the help of ray diagram, when a ray of light passes through a rectangular glass slab.
- 369) Size of image of an object by a mirror having a focal length of 20 cm is observed to be reduced to  $\frac{1}{3}$  rd of its size. At what distance the object has been placed from the mirror? What is the nature of the image and the mirror?
- 370) The image of a candle flame formed by a lens is obtained on a screen placed on the other side of the lens. If the image is three times the size of the flame and the distance between lens and image is 80 cm, at what distance should the candle be placed from the lens? What is the nature of the image at a distance of 80 cm and the lens?
- 371) Define power of a lens. What is its unit? One student uses a lens of focal length 50 cm and another of -50 cm. What is the nature of the lens and its power used by each of them?
- 372) A student focussed the image of a candle flame on a white screen using a convex lens. He noted down the position of the candle screen and the lens as under  
 Position of candle = 12.0 cm  
 Position of convex lens = 50.0 cm  
 Position of the screen = 88.0 cm  
 (a) What is the focal length of the convex lens?  
 (b) Where will the image be formed if he shifts the candle towards the lens at a position of 31.0 cm?  
 (c) What will be the nature of the image formed if he further shifts the candle towards the lens?  
 (d) Draw a ray diagram to show the formation of the image in case c) as said above.
- 373) The image of a candle flame place at a distance of 36 cm from a spherical lens is formed on a screen place at a distance of 72 cm from the lens. Identify the type of lens and calculate its focal length. If the height of the flame is 2.5 cm, find the height of the image.
- 374) A spherical mirror produces an image of magnification -1 on a screen placed at a distance of 50 cm from the mirror.  
 (a) Write the type of mirror  
 (b) Find the distance of the image from the object.  
 (c) What is the focal length of the mirror?  
 (d) Draw the ray diagram to show the image formation in this case.
- 375) State the laws of refraction of light. If the speed of light in vacuum is  $3 \times 10^8 \text{ ms}^{-1}$ , find the speed of light in a medium of absolute refractive index 1.5.
- 376) A spherical mirror produces an image of magnification -1 on a screen at a distance of 40 cm from the mirror.  
 (i) Write the type of mirror  
 (ii) What is the nature of the image formed?  
 (iii) How far is the object located from the mirror?  
 (iv) Draw the ray diagram to show the image formation in this case.
- 377) An object of height 6 cm is placed perpendicular to the principal axis of a concave lens of focal length 5 cm. Use lens formula to determine the position, size and nature of the image if the distance of the object from the lens is 10 cm.
- 378) A spherical mirror produces an image of magnification - 1.0 on a screen placed at a distance of 30 cm from the pole of the mirror.  
 (i) Write the type of mirror in this case.  
 (ii) What is the focal length of the mirror?  
 (iii) What is the nature of the image formed?  
 (iv) Draw the ray diagram to show the image formation in this case.

- 379) An object of height 5 cm is placed perpendicular to the principal axis of a concave lens of focal length 10 cm. Use lens formula to determine the position, size and nature of the image if the distance of the object from the lens is 20 cm.
- 380) An object of height 4 cm is kept at a distance of 30 cm from a concave lens. Use lens formula to determine the image distance, nature and size of the image formed if focal length of the lens is 15 cm.
- 381) The image of a candle flame placed at a distance of 45 cm from a spherical lens is formed on a screen placed at a distance of 90 cm from the lens. Identify the type of lens and calculate its focal length. If the height of the flame is 2 cm, find the height of its image.
- 382) The image of a candle flame placed at a distance of 30 cm from a spherical lens is formed on a screen placed at a distance of 60 cm from the lens. Identify the type of lens and calculate its focal length. If the height of the flame is 2.4 cm, find the height of its image
- 383) The image of an object formed by a mirror is real, inverted and is of magnification -1. If the image is at a distance of 40 cm from the mirror, where is the object placed? Where would the image be if the object is moved 20 cm towards the mirror? State reason and also draw ray diagram for the new position of the object to justify your answer.
- 384) The image formed by a spherical mirror is real, inverted and is of magnification -2. If the image is at a distance of 30 cm from the mirror, where is the object place? Find the focal length of the mirror. List two characteristics of the image formed if the object is moved 10 cm towards the mirror.
- 385) If the image formed by a mirror for all positions of the object placed in front of it is always erect and diminished, what type of mirror is it? Draw a ray diagram to justify your answer. Where and why do we generally use this type of mirror?
- 386) (i) One half of a convex lens of focal length 10 cm is converted with a black paper. Can such a lens produce an image of a complete object placed at a distance of 30 cm from the lens? Draw ray diagram to justify your answer.  
(ii) A 4 cm tall object is placed perpendicular to the principal axis of a convex lens of focal length 20 cm. The distance of the object from the lens is 15 cm. Find nature, position and size of the image.
- 387) (a) Define focal length of a divergent lens.  
(b) A divergent lens of focal length 30 cm forms the image of an object of size 6 cm on the same side as the object at a distance of 15 cm from its optical centre. Use lens formula to determine the distance of the object from the lens and the size of the image formed.  
(c) Draw a ray diagram to show the formation of image in the above situation.
- 388) (a) Define focal length of a spherical lens.  
(b) A divergent lens has a focal length of 30 cm. At what distance should an object of height 5 cm from the optical centre of the lens be placed so that its image is formed 15 cm away from the lens? Find the size of the image also.  
(c) Draw a ray diagram to show the formation of image in the above situation.
- 389) (a) Define optical centre of a spherical lens.  
(b) A divergent lens has a focal length of 20 cm At what distance should an object of height 4 cm from the optical centre of the lens be placed so that its image is formed 10 cm away from the lens. Find the size of the image also.  
(c) Draw a ray diagram to show the formation of image in above situation.
- 390) It is desired to obtain an erect image of an object, using concave mirror of focal length of 12 cm  
(i) What should be the range of distance of an object placed in front of the mirror?  
(ii) Will the image be smaller or larger than the object? Draw ray diagram to show the formation of image in this case.  
(iii) Where will the image of this object be, if its placed 24 cm in front of the mirror?  
Draw a ray diagram for this situation also to justify your answer.  
Show the positions of the pole, the principal and the centre of curvature in the above ray diagrams.

- 391) (a) If the image formed by a lens is diminished in size and erect, for all positions of the object, what type of lens is it?  
 (b) Name the point on the lens through which a ray of light passes undeviated.  
 (c) An object is placed perpendicular to the principal axis of a convex lens of focal length 20 cm. The distance of the object from the lens is 30 cm. Find.  
 (i) the position  
 (ii) the magnification and  
 (iii) the nature of the image formed

- 392) (a) One - half of a convex lens is covered with a black paper. Will such a lens produce an image of the complete object? Support your answer with a ray diagram.  
 (b) An object 5 cm high is held 25 cm away from a converging lens of focal length 10 cm.  
 (i) Draw the ray diagram and  
 (ii) Calculate the position and size of the image formed.  
 (iii) What is the nature of the image?

- 393) Define the term absolute refractive index. The absolute refractive index of diamond is 2.42. What is the meaning of this statement? Refractive indices of media A, B C and D are given below:

Media	Refractive Index
A	1.33
B	1.44
C	1.52
D	1.65

In which of these four media is the speed of light (i) minimum and (ii) maximum?  
 Find the refractive index of medium C with respect to medium B.

- 394) (i) State Snell's law of refraction of light. Write an expression to relate refractive index of a medium with speed of light in vacuum.  
 (ii) The refractive index of a medium 'a' with respect to medium 'b' is  $\frac{2}{3}$  and the refractive index of medium 'b' with respect to medium 'c' is  $\frac{4}{3}$ . Find the refractive index of medium 'c' with respect to medium 'a'.
- 395) (a) State the laws of refraction of light. Give an expression to relate the absolute refractive index of a medium with speed of light in vacuum.  
 (b) The refractive indices of water and glass with respect to air are  $\frac{4}{3}$  and  $\frac{3}{2}$  respectively. If the speed of light in glass is  $2 \times 10^8 \text{ ms}^{-1}$ , find the speed of light in (i) air, (ii) water.
- 396) A student wants to project the image of a candle flame on the walls of school laboratory by using a mirror  
 (a) Which type of mirror should he use and why?  
 (b) At what distance in terms of focal length 'f' of the mirror should he place the candle flame so as to get the magnified image on the wall?  
 (c) Draw ray diagram to show the formation of image in this case.  
 (d) Can he use this mirror to project a diminished image of the candle flame on the same wall? State 'how' if your answer is 'yes' and 'why not' if your answer is 'no'
- 397) A student wants to project the image of candle flame on the walls of school laboratory by using a lens:  
 (a) Which type of lens should he use any why?  
 (b) At what distance in terms of focal length 'F' of the lens should he place the candle flame so as to get  
 (i) a magnified, and  
 (ii) a diminished image respectively on the wall?  
 (c) Draw ray diagram to show the formation of the image in each case.
- 398) (i) " A convex lens can form a magnified erect as well as magnified inverted image of an object placed in front of it. " Draw ray diagram to justify this statement stating the position of the object with respect to the lens in each case.  
 (ii) As object of height 4 cm is placed at a distance of 20 cm from a concave lens of focal length 10 cm. Use lens formula to determine the position of the image formed.