

MINISTRY OF EDUCATION AND SCIENCE OF UKRAINE

Oleksandr Dovzhenko Hlukhiv National Pedagogical University

EDUCATIONAL AND PROFEIONAL PROGRAM

«PSYCHOLOGY»

second (master) level of higher education

On specialty 053 «Psychology»

Field of education 05 «Social and behavioral sciences»

Qualification: Master of psychology. Psychologist.

APPROVED

By academic council of . Dovzhenko Hlukhiv NPU
Head of academic council _____ prof. Oleksandr
KUROK
(protocol № ___ dated «_» _____ 2022)

Educational program comes into force from 01.09.2021
Rector _____ prof. Oleksandr KUROK

Hlukhiv 2022

LETTER AGREEMENT
Of educational and professional program

APPROVED

Pedagogy, Psychology, Social Work and
Management Chair

Protocol № _____

dated «__» _____ 20__

Head of the chair

_____ prof. H. LUTSENKO

APPROVED

By academic council of ERI
of Pedagogy and Psychology

Protocol № _____

dated «__» _____ 20__

Head of the academic council

_____ Associate professor A.
SHERUDYLO

PREFACE

Educational and professional program is developed by Psychology and Social Work Chair of Oleksandr Dovzhenko Hlukhiv National Pedagogical University.

Head of the project team (guarantor of the educational program):

Ilina Nina Mykhailivna – PhD in Psychology, Associate Professor, Associate Professor of the of Psychology and Social Work Chair.

Project team members:

Zhuravel Anna Vasylivna – Candidate of Psychological Sciences, Senior Lecturer of of Psychology and Social Work Chair.

Riabko Yurii Volodymyrovych – Assistant of the of the of Psychology and Social Work Chair, Practical Psychologist of Oleksandr Dovzhenko Hlukhiv National Pedagogical University.

1. 1. Profile of educational program on specialty № 053 «Psychology»

1 – Загальна інформація	
Full name of higher education establishment and structural division	Oleksandr Dovzhenko Hlukhiv National Pedagogical University Educational and Research Institute of Pedagogy and Psychology Psychology and Social Work Chair
Degree of higher education and name of qualification in original language	Complete higher education Qualification: Master of Psychology. Psychologist.
Official name of educational program	Master's educational and professional program
Diploma type and amount of educational program	Master's Diploma, single, 90 ECTS credits , Term of study 1.4 years
Availability of accreditation	Certificate НД-IV № 1923286 dated January 8 2013, issued by Accreditation Committee of Ukraine. Valid until July 01, 2022
Cycle/level	HPK – 7 level, FQ-EHEA – second cycle, EQF-LLL – 7 level
Preconditions	Availability of basic higher education (bachelor's degree) or complete higher education (specialist's degree), which is confirmed by the relevant state standard document. The applicant should not have adverse medical and psychological contraindications to work in the chosen profession, in particular: mental retardation; neuroses and psychopathies; neurotic disorders; initial symptoms of mental illness, etc. Admission is carried out on the results of internal entrance examinations in the following subjects: "Foreign language (English)", "Psychology". For applicants of unrelated specialties (by cross-entry), an additional entrance examination in subjects is obligatory: "Ukrainian language".
Language of teaching	Ukrainian
Duration of educational program	The educational program is valid until July 01 2022
Internet address of constant placement of educational program	http://new.gnpu.edu.ua http://pp.gnpu.edu.ua
2 – Objective of educational program	
The educational and professional program is a document that determines the normative content of study, requirements are established to the content, scope and level of educational and professional training of the Master of Psychology. Objective of the educational program is training of specialists of high level who master fundamental knowledge and skills of organization of educational and research activity, practical skills of providing applied psychological assistance to all participants of the educational process in educational institutions,	

the formation of their key professional competencies in accordance with modern social and cultural conditions of society.	
3 – Characteristics of the educational program	
Subject area (Field of knowledge, specialty, specialization (in the presence))	Subject area (Field of knowledge, specialty, specialization (in the presence))
Orientation of educational and professional program	Orientation of educational and professional program
Main focus of educational program and specialization	<p>General higher education in the field of knowledge 05 "Social and behavioral sciences".</p> <p>The structure of the program provides for the mastering of basic knowledge of psychotherapeutic methods of emotional self-regulation, psychological methods and techniques for predicting and resolving interpersonal and intergroup conflicts, psychological aspects of ethnic processes and ways to model strategies for their further development; regarding modern scientific ideas about stress and its nature, about the peculiarities of stress deployment, its varieties, about carrying out advisory work on stressful situations, stress resistance, prevention of negative consequences of stress, formation of the ability to experience stressful situations and their negative consequences optimally; regarding scientific approaches to the organization and conduction of independent art-therapeutic (both individual and group) work; regarding the meaning, structure and functions of the labor market and its main tendencies, peculiarities of organization and activity of psychological services; regarding psychological support of professional formation of the personality, development of career competencies of specialists of different profiles, formation of the image of the organization (in particular, the educational institution); regarding the methodological foundations of research, analysis of scientific problems in the field of psychology, theoretical and applied justification of options for their optimal solution, formulation of science-based conclusions on the basis of empirical data; on the organization of the educational process, as well as the content and tasks of all forms of work in higher education, pedagogical management as a necessary element of the teaching and educational process in higher education, modern scientific technologies of teaching disciplines of the humanitarian cycle, typology and norms of professional communication, scientific and organizational foundations of labor protection.</p>
Features of the educational and professional program	<p>EP requires special training. The EP takes into account the latest requirements regarding the connection of theory with practice, is focused on a thorough special training of psychologists, initiative and capable of fundamental analysis of modern tendencies in the field of psychology. It forms psychologists with a strategic way of thinking, able not only to apply the gained knowledge, but also to generate new ones on the basis of modern achievements of science and practice.</p>
4 – Suitability of graduates for employment and further education	
Suitability for	Master in the specialty 053 "Psychology" can fulfill professional work in accordance with the State Classifier of Professions SCP 003: 2010 (as

employment	amended), approved by the order of the Ministry of Economic Development and Trade of Ukraine dated March 4, 2016 № 394), and has the right to hold the following positions: psychologist, practical psychologist, junior researcher, consultant of psychological, medical and pedagogical commission, scientific consultant in state and public institutions, psychologist of marketing departments of campaigns and departments for work with staff, head of structural division - chief specialist, consultant on healthy lifestyle, head of projects and programs in the field of intangible production.
Further education	Master student of specialty 053 "Psychology" can continue to study at the third level of higher education (Doctor of Philosophy PhD) on specialty 053 "Psychology" and other related specialties.
5 – Teaching and evaluation	
Teaching and education	Problem-based learning, student-centered learning, self-study, learning through special practice are used in the EP.
Evaluation	Cumulative point-rating system, which includes the evaluation of students for all types of classroom and extracurricular activity through the use of various forms of control: oral and written questioning, testing, presentation of project works, defense of practical and individual works, credits, oral and written exams, defense of practice, defense of master's work, etc. Evaluation of educational achievements: 4-point national scale (excellent, good, satisfactory, unsatisfactory); 2-level national scale (credited/not credited); 100-point scale according to ECTS system.
6 – Program competence	
Integral Competence	Здатність компетентно вирішувати складні завдання і проблеми у процесі навчання та професійної діяльності у галузі психології, здійснювати професійну діяльність з урахуванням загальнолюдських цінностей та норм професійної етики психолога, що передбачає комплексне та доцільне застосування концептуальних теорій та методів психологічної науки, проведення досліджень та/або здійснення інновацій і характеризується комплексністю та невизначеністю умов і вимог.
General competencies (GC)	GC 1. Ability to apply knowledge in practical situations. GC 2. Ability to carry out research at the appropriate level. GC 3. Ability to generate new ideas (creativity). GC 4. Ability to identify, formulate and solve problems. GC 5. Valuing and respecting diversity and multiculturalism. GC 6. Ability to act on the basis of ethical reasons (motives). GC 7. Ability to act in a socially responsible and conscious manner. GC 8. Ability to develop and manage projects. GC 9. Ability to motivate people and move towards a common goal. GC 10. Ability to speak a foreign language.
Professional (special,subjective) competences (PK)	PK1. Ability to carry out theoretical, methodological and empirical analysis of topical issues of psychological science and / or practice. PK 2. Ability to plan, organize and carry out psychological research with elements of scientific novelty and / or practical relevance. PK 3. Ability to select and apply valid and reliable methods of scientific research and/or evidence-based methods and techniques of practice. PK 4. Ability to carry out practical activities (training, psychotherapeutic, consulting, psychodiagnostic and others according to

	<p>specialization) using scientifically verified methods and techniques.</p> <p>PK 5. Ability to organize and implement educational activity for different categories of population in the field of psychology.</p> <p>PK 6. Ability to interact effectively with colleagues in mono- and multidisciplinary teams.</p> <p>PK 7. Ability to make professional decisions in difficult and unpredictable conditions, adapt to new situations of professional activity.</p> <p>PK 8. Ability to assess the limits of own professional competence and improve professional skills.</p> <p>PK 9. Ability to adhere to the norms of professional ethics in professional activity and be guided by common human values.</p> <p>PK 11. Ability to develop and implement innovative methods of psychological assistance to clients in difficult life situations.</p>
<p>7 – Program results of education</p>	
	<p>PRE 1. To carry out search, processing and analysis of professionally important knowledge from various sources using modern information and communication technologies.</p> <p>PRE 2. To be able to organize and conduct psychological research using valid and reliable methods.</p> <p>PRE 3. Generalize empirical data and formulate theoretical conclusions.</p> <p>PRE 4. Make psychological predictions about the development of individuals, groups, organizations.</p> <p>PRE 5. Develop programs of psychological interventions (training, psychotherapy, counseling, etc.), conduct them in individual and group work, evaluate quality.</p> <p>PRE 6. Develop educational materials and educational programs, implement them, receive feedback, evaluate quality.</p> <p>PRE 7. Accessibly and reasonably present research results in written and oral forms, participate in professional discussions.</p> <p>PRE 8. Evaluate the degree of difficulty of the tasks of the activity and make a decision on seeking help or advanced training.</p> <p>PRE 9. Solve ethical dilemmas based on the law, ethical principles and universal human values.</p> <p>PRE 12. To carry out an analytical search for scientific information relevant to the formulated problem and evaluate it according to the criteria of adequacy.</p> <p>PRE 13. To carry out adaptation and modification of existing scientific approaches and methods to specific situations of professional activity.</p>
<p>8 – Resource support of program implementation</p>	
<p>Staffing</p>	<ol style="list-style-type: none"> 1. Availability in the educational institution of a subdivision or chair responsible for the training of higher education applicants. 2. In order to start educational activities: the presence of a project group responsible for the training of higher education applicants on a particular specialty which consists of research and teaching staff working at the main place of work: one Doctor of Science (Professor) and two Doctors of Philosophy / Associate Professor (Professor) of the appropriate specialty who have at least five years of experience in scientific and pedagogical work and have been conducting research on the appropriate specialty for the last five years. 3. In order to implement educational activities: the availability of a project team responsible for the training of applicants of higher education on a particular specialty which consists of research and teaching staff

	<p>working at the main place of work: one Doctor of Science (Professor) and two Doctors of Philosophy / Associate Professor (Professor) on the appropriate specialty for every twenty applicants.</p> <p>4. Carrying out training sessions by scientific and pedagogical (scientific) staff of the appropriate specialty at the main place of work (minimum percentage of the hours defined by the curriculum): 1) who have a scientific degree and / or academic title (until September 6, 2019 for the elementary level taking into account pedagogical workers who have a higher category) - 50; 2) who have a doctoral degree or academic title of professor - 25.</p> <p>5. Conducting lectures on academic disciplines that provide the formation of professional competencies by scientific and pedagogical (scientific) workers who are recognized professionals with experience in the specialty (minimum percentage of hours determined by the curriculum): research, innovation, management or creative work in the specialty - 15.</p> <p>6. Conducting lectures, practical, seminars and laboratory classes, carrying out scientific supervision of the course works, diploma works (projects), dissertation research by scientific and pedagogical (scientific) workers, the level of scientific and professional activity of each certified by the carrying out of at least three conditions specified in subparagraphs 1-16 of paragraph 5 of the notes of Annex 10 of the Licensing Conditions for the educational activities of educational institutions (Resolution of the Cabinet of Ministers of Ukraine of December 30, 2015 No. 1187).</p> <p>7. Advanced training of scientific and pedagogical, pedagogical and scientific staff is carried out every 5 years.</p>
Logistical support	<p>1. Providing premises for conducting training and control activities (square meters per person for the licensed volume of students and the declared volume, taking into account training in shifts) (no more than two shifts are taken into account) - 2.4.</p> <p>2. Availability of multimedia equipment for simultaneous use in classrooms (minimum percentage of the number of classrooms) - 30.</p> <p>3. Availability of social infrastructure: 1) library, including a reading room; 2) catering facilities; 3) assembly or concert hall; 4) gym; 5) stadium and/or sports grounds; 6) medical center.</p> <p>4. Providing higher education students with a dormitory (minimum percentage of need) - 70.</p> <p>5. Availability of security service (in case of training of foreign citizens).</p> <p>6. Availability of passport and visa service for foreign citizens (in case of training of foreign citizens).</p> <p>7. Providing computer workstations, laboratories, testing grounds, equipment, facilities necessary for the implementation of curricula.</p>
Information and educational and methodological support	<p>1. Providing the library with domestic and foreign professional periodicals of the relevant or related profile, including in electronic form: at least four titles.</p> <p>2. Availability of access to databases of periodical scientific publications in English of the relevant or related profile (it is allowed joint use of databases by several educational institutions).</p> <p>3. Availability of the official website of the educational institution which contains basic information about its activities (structure, licenses and certificates of accreditation, educational/educational-scientific/publishing/attestation (of scientific personnel) activities, educational and scientific structural units and their composition, list of</p>

	<p>disciplines, admission rules, contact information).</p> <p>4. Availability of an electronic resource of the educational institution, which contains teaching and methodological materials on the disciplines of the curriculum, including in the distance learning system (minimum percentage of disciplines) - 60.</p> <p>5. Availability of educational program.</p> <p>6. Availability of the educational plan.</p> <p>7. Availability of a working program for each academic discipline of the curriculum.</p> <p>8. Availability of a set of educational and methodological support for each discipline of the curriculum.</p> <p>9. Availability of practical training program, work programs of practices.</p> <p>10. Providing students with teaching materials for each discipline of the educational plan.</p> <p>11. Availability of methodical materials for certification of applicants.</p>
9 – Academic mobility	
National credit mobility	Concluded agreement on cooperation and double certification with the Higher Linguistic School in Czestochowa (Poland) which is included to the register of non-governmental educational institutions and association of non-governmental educational institutions on the basis of the law of 12 September 1990 on higher education.
International credit mobility	
Education of higher education foreign students	Is not practiced

2. List of educational program components and their logic consequence.

2.1. List of EP components

Code n/d	Components of educational and professional program (educational disciplines, course projects (works), practices, qualification work)	Amount of credits	Form of control
1	2	3	4
Obligatory components of the EP			
OK1.1.1	Phhylosophy of education	3	Exam
OK1.1.2	Culture of scientific Ukrainian language	3	Credit
OK1.1.3	Foreign language for professional purposes	3	Credit
OK1.1.4	Human genetics	3	Exam
OK1.2.1.	Academic integrity	3	Credit
OK1.2.2.	Intellectual property		
OK1.2.3.	Basics of intercultural communication		
OK1.2.4.	Professional career		
OK1.2.5.	Distance learning as a modern educational technology		
OK1.2.6.	Discipline of another EP (choice from the general university list)		
OK 2.1.1	Innovative pedagogy	3	Exam

OK 2.1.2	Educational psychology	3	Exam
OK 2.1.3	Methods of teaching psychology in higher educational institutions	3	Exam
OK 2.1.4	Psychology of stress	4	Credit
OK 2.1.5	Gerontopsychology	4	Exam
OK 2.1.6	Political psychology	3	Credit
OK 2.1.7	Conflicts in the institution of general secondary education	3	Exam
OK 2.1.8	Art therapy	3	Credit
OK 2.1.9	Psychology of professional career	3	Credit
OK 3.1.1	Traineeship at the workplace of a practical psychologist	6	Credit
OK 3.1.2	On the job as a psychologist in institutions of higher professional education	6	Credit
OK 3.1.3	Research practice (writing a master's thesis)	4	Credit
OK 3.2	Comprehensive preparation of master's research		Credit
OK3.2.1.	Information technologies in research activities	3	Credit
OK 3.2.2	Academic rhetoric	3	Credit
OK 3.2.3	Methodology and methods of scientific research	3	Credit
OK4.1.1.	Master's work	1	Exam
OK4.1.2.	Comprehensive exam in psychology	1	Exam
Total amount of obligatory components of:		71	
<i>Selective block (student's choice)</i>			
BK 2.2.1	Selective component 1	5	Exam
BK 2.2.2.	Selective component 2	5	Exam
BK 2.2.3.	Selective component 3	5	Exam
BK 2.2.4	Selective component 4	4	Credit
Total amount of selective components		19	
TOTAL AMOUNT OF THE EDUCATIONAL PROGRAM		90	

2.2. Structural and logical scheme of the EP.

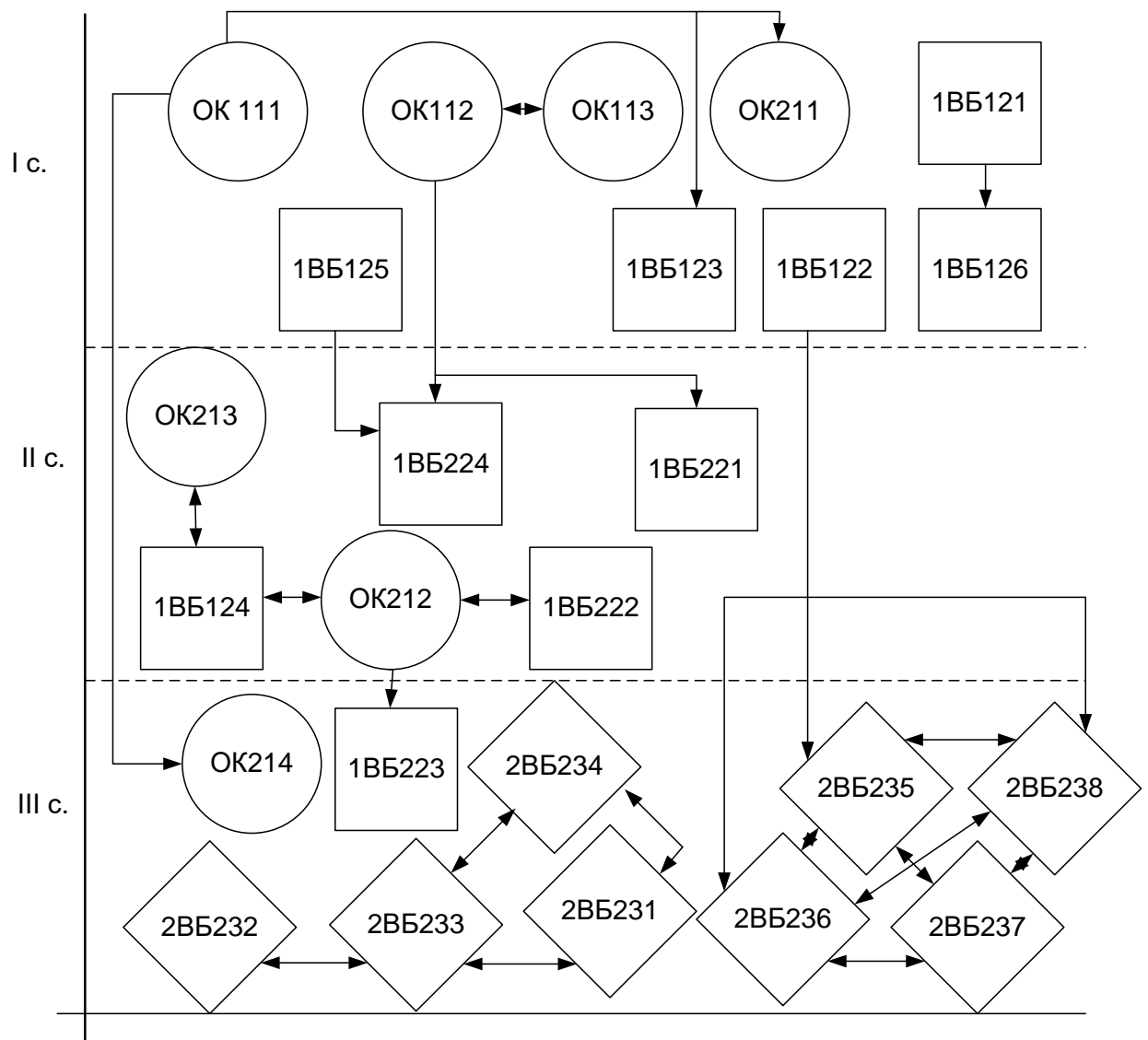

Symbols of educational program components:

- - obligatory components of the EP
- - components of selective block 1 (choice of educational institution)
- ◇ - components of selective block 2 (student's choice)

Code of academic disciplines - according to the table in paragraph 2.1.

3. Form of students certification

The final state certification of graduates of the educational program of specialty 053 "Psychology" is carried out in the form of a state exam in psychology and the defense of a qualifying master's work in psychology and ends with the issuance of a document of the established sample on awarding a master's degree with the qualification "Master of Psychology. Psychologist".

The state exam is a public comprehensive test of knowledge and skills of graduates mainly in the disciplines of the psychological cycle provided by the educational plan.

Qualification work is a comprehensive theoretical and empirical research that has scientific novelty and practical significance in the practice of providing psychological assistance and the practice of pedagogical activity.

Certification is carried out openly and publicly.

4. Conformity matrix of program competences to the components of educational program

4.1. Obligatory components of the EP

	ЗК 1	ЗК 2	ЗК 3	ЗК 4	ЗК 5	ЗК 6	ЗК 7	ЗК 8	ЗК 9	ЗК1 0	ФК 1	ФК 2	ФК 3	ФК 4	ФК 5	ФК 6	ФК 7	ФК 8	ФК 9	Ф К 11
OK 1.1. 1	+		+	+	+	+	+	+	+		+				+	+		+	+	+
OK 1.1. 2	+	+		+	+	+	+		+	+					+	+	+	+	+	
OK 1.1. 3	+		+	+	+	+			+	+						+	+	+		
OK 1.1. 4	+	+			+	+	+		+		+				+	+		+	+	
OK 1.2. 1.	+			+	+	+	+	+	+						+	+	+	+	+	+
OK 1.2. 2.	+		+	+	+	+	+	+	+						+	+		+	+	+
OK 1.2. 3.	+	+	+	+	+	+	+	+	+	+	+				+	+		+	+	
OK 1.2. 4.	+	+	+	+	+	+	+	+	+	+	+	+			+	+	+	+	+	+
OK 1.2. 5.	+	+	+	+	+	+	+	+	+						+	+	+	+		
OK 1.2. 6.	+			+	+	+	+	+	+		+				+	+		+	+	
OK 2.1.	+	+	+	+	+	+	+	+	+		+				+	+		+	+	+

1																				
OK 2.1. 2	+	+	+	+	+	+	+	+	+		+	+	+	+	+	+		+	+	+
OK 2.1. 3	+	+	+	+	+	+	+	+	+		+		+			+		+		
OK 2.1. 4	+	+		+	+	+	+	+	+		+	+			+	+		+		+
OK 2.1. 5	+			+	+	+	+	+	+		+	+			+					+
OK 2.1. 6	+	+		+	+	+	+	+	+		+	+			+	+		+	+	+
OK 2.1. 7	+	+	+	+	+	+	+	+	+		+				+	+		+		+
OK 2.1. 8	+		+	+	+	+	+		+		+								+	+
OK 2.1. 9	+	+	+	+	+	+	+	+	+		+					+		+	+	+
OK 3.1. 1	+	+	+	+	+	+	+	+	+		+	+	+	+		+		+		
OK 3.1. 2	+	+	+	+	+	+	+	+	+		+	+	+	+	+	+		+	+	+
OK 3.1. 3	+	+	+	+	+	+	+		+		+	+	+	+		+		+	+	+
OK 3.2. 1	+	+		+		+	+		+	+						+		+		
OK 3.2. 2	+		+	+	+	+	+		+						+	+		+		
OK 3.2. 3	+	+	+	+	+	+	+				+	+	+							
OK 4.1. 1.	+	+	+	+	+	+	+				+	+	+	+						
OK 4.1. 2	+			+							+	+	+	+						

5. Matrix of providing program results of education (PRN) to the appropriate components of educational program

4.1. Obligatory components of the EP

