

MINISTRY OF EDUCATION AND SCIENCE OF UKRAINE

Oleksandr Dovzhenko Hlukhiv National Pedagogical University

**EDUCATIONAL AND PROFESSIONAL PROGRAM**

**«PSYCHOLOGY»**

First (bachelor) level of higher education

**On specialty 053 «Psychology»**

**Field of education 05 «Social and behavioral sciences»**

**Qualification:** Bachelor of psychology. Psychologist.

**APPROVED**

Approved by the academic council of O. Dovzhenko Hlukhiv  
NPU

Head of academic council \_\_\_\_\_ prof. Oleksandr  
(protocol № \_\_\_ dated « \_\_\_ » \_\_\_\_\_ 2021)

Educational program is in the operation since 01.09.2021

Rector \_\_\_\_\_ prof. O.I. Kurok

**LETTER AGREEMENT**  
**Of educational and professional program**

APPROVED

Pedagogy, Psychology, Social Work and  
Management Chair

Protocol № \_\_\_\_\_

dated «\_\_» \_\_\_\_\_ 20\_\_

Head of the chair

\_\_\_\_\_ prof. H. LUTSENKO

APPROVED

By academic council of ERI  
of Pedagogy and Psychology

Protocol № \_\_\_\_\_

dated «\_\_» \_\_\_\_\_ 20\_\_

Head of the academic council

\_\_\_\_\_ senior lecturer

A. SHERUDYLO

## **PREFACE**

Educational and professional program is developed by Psychology and Social Work Chair of Oleksandr Dovzhenko Hlukhiv National Pedagogical University.

Head of the project team ( guarantor of the educational program):

Ilina Nina Mykhailivna – PhD in Psychology, Associate Professor, Associate Professor of the of Psychology and Social Work Chair.

Project team members:

Zhuravel Anna Vasylivna – Candidate of Psychological Sciences, Senior Lecturer of of Psychology and Social Work Chair.

Riabko Yurii Volodymyrovych – Assistant of the of the of Psychology and Social Work Chair.

## 1. Profile of educational program on specialty № 053 «Psychology»

1 – General information	
Full name of higher education establishment and structural division	Oleksandr Dovzhenko Hlukhiv National Pedagogical University Educational and Research Institute of Pedagogy and Psychology Psychology and Social Work Chair
Degree of higher education and name of qualification in original language	Basic higher education Qualification: Master of Psychology. Psychologist.
Official name of educational program	Educational and professional bachelor's program
Diploma type and amount of educational program	Bachelor's degree, single, 240 ECTS credits, Duration of study 4 years
Availability of accreditation	Certificate НД-IV № 1923286 dated January 8 2013, issued by Accreditation Committee of Ukraine. Valid until July 01, 2022
Cycle/level	NFQ Ukraine – 6 level, EQ-EHEA – first cycle, EQF-LLL – 6 level
Preconditions	Availability of a complete general secondary education which is confirmed by a relevant state-approved document. The applicant must have a high-quality educational background within the requirements of the independent testing center. The applicant should not have adverse medical and psychological contraindications to work in the chosen profession, in particular: mental retardation; neuroses and psychopathies; neurotic disorders; initial symptoms of mental illness, etc. Admission is based on general admission conditions: on the results of the competition of certificates of external independent testing of knowledge and skills (EIT) on subjects: "Ukrainian Language and Literature", "History of Ukraine" and "Biology / Mathematics" taking into account the average score of the document on complete general secondary education
Language of teaching	Ukrainian
Duration of educational program	Duration of the educational program until Термін дії освітньої програми до 01 July 2023
Internet address of constant placement of educational program	<a href="http://new.gnpu.edu.ua">http://new.gnpu.edu.ua</a> <a href="http://pp.gnpu.edu.ua">http://pp.gnpu.edu.ua</a>
2 – Objective of educational program	
The educational and professional program is a document that defines the normative content of training, establishes requirements for the content, scope and level of educational and professional training of a bachelor's degree in psychology. The purpose of the educational program is the professional and personal development of bachelors of psychology, the gaining of psychological knowledge, mastering practical skills in providing applied psychological	

assistance to all participants in the educational process in educational institutions, the formation of their key professional competencies in accordance with modern socio-cultural conditions of society.

3 – Characteristics of the educational program

Subject area (Field of knowledge, specialty, specialization (in the presence))	Field of knowledge - 05 "Social and behavioral sciences" Specialty - 053 "Psychology"
--	--

Orientation of educational and professional program	Educational and professional The structure of the program provides for the gaining of basic knowledge of the essence and patterns of mental phenomena, the material substrate of the mental, the anatomy and evolution of the nervous system, peculiarities of historical development of the psyche and patterns of mental development at different stages of ontogeny, structure and theories of personality, causes and manifestations of mental illness, socio-psychological mechanisms of behavior regulation and psychological aspects of mass communications; regarding the organization and carrying out of systematic psychological research of the personality and the team, the basic principles and theories of providing qualified psychological advisory assistance and mechanisms of collective influence, organization and activity of psychological services; on the implementation of psychological education on mental health and psychological well-being of individuals and groups of people; on the methodological basis of research work
---	---

Main focus of educational program and specialization	General education in the field of knowledge 05 "Social and behavioral sciences"
--	---

Features of the program	The EP requires a special practice. The EP takes into account the latest requirements for the connection of theory with practice, is focused on a thorough special training of psychologists, initiative and capable to analyze fundamentally modern trends in the field of psychology. Forms psychologists with a strategic way of thinking, able not only to apply the acquired knowledge, but also to generate new ones based on modern achievements of science and practice
-------------------------	---

4 – Suitability of graduates for employment and further education

Suitability for employment	A Bachelor in specialty 053 "Psychology" can hold primary positions in psychotherapeutic, psychological, counseling services; in social organizations (centers of social services for families, children and youth, children's centers for creativity and leisure, orphanages, shelters, nursing homes); in healthcare institutions (hospitals, clinics, special schools for disabled children, drug treatment and rehabilitation centers); in recruitment and selection institutions (recruitment agencies, employment centers, career guidance centers); in companies, small enterprises and business structures; in law enforcement agencies (juvenile justice institutions, colonies, distributors); in the trust service; in the system of the Ministry of Emergency Situations (customs, rescue services, military organizations)
----------------------------	---

Further education	Bachelor in specialty 053 "Psychology" can continue their education at the second (master's) level of higher education in the specialty 053 "Psychology" and other related specialties (second cycle FQ-EHEA)
-------------------	---

	program, level 7 EQF-LLL and level 7 HPK)
5 – Teaching and evaluation	
Teaching and education	Problem-based learning, student-centered learning, self-study, and learning based on special practice are used in the EP
Evaluation	Oral and written exams, testing, practice, essays, presentations, project work, etc.
6 – Program competence	
Integral competence	Ability to solve complex specialized tasks and practical problems in the professional activity of a practical psychologist which provides for the complex and appropriate application of theories and methods of psychological science
General competencies (GC)	<p>GC 1. Ability to apply knowledge in practical situations.</p> <p>GC 2. Knowledge and understanding of subject field and professional activity.</p> <p>GC 3. Skills of using the informational and communicational technologies.</p> <p>GC 4. Ability to study and master modern knowledge.</p> <p>GC 5. Ability to be critical and self-critical.</p> <p>GC 6. Ability to make reasonable decisions.</p> <p>GC 7. Ability to generate new ideas (creativity).</p> <p>GC 8. Skills of interpersonal interaction</p> <p>GC 9. Ability to work in a team.</p> <p>GC 10. Ability to implement own rights and responsibilities as a member of society, to realize the values of civil (free democratic) society and the need for its sustainable development, the rule of law, human and civil rights and freedoms in Ukraine;</p> <p>GC 11. The ability to preserve and multiply moral, cultural, scientific values and achievements of society based on an understanding of history and patterns of development.</p>
Professional (special,subjective) competences (PC)	<p>PC 1. Ability to operate with the categorical and conceptual apparatus of psychology</p> <p>PC 2. Ability to analyze retrospectively domestic and foreign experience on the nature of the emergence, functioning and development of mental phenomena.</p> <p>PC 3. Ability to understand the nature of behavior, activities and actions.</p> <p>PC 4. Ability to collect and critically process, analyze and generalize psychological information from various sources independently</p> <p>PC 5. Ability to use valid and reliable psychodiagnostic tools</p> <p>PC 6. Ability to plan, organize and conduct psychological research independently</p> <p>PC 7. Ability to analyze and systematize the obtained results, formulate reasoned conclusions and recommendations</p> <p>PC 8. Ability to organize and provide psychological assistance (individual and group)</p> <p>PC 9. Ability to carry out educational and psychoprophylactic activities as request</p> <p>PC 10. Ability to adhere to the norms of professional ethics</p> <p>PC 11. Ability to personal and professional self-improvement, education and self-development</p>
7 – Program results of education	

	<p>PRE 1. Analyze and explain mental phenomena, identify psychological problems and suggest ways to solve them</p> <p>PRE 2. Understand the patterns and features of the development and functioning of mental phenomena in the context of professional tasks</p> <p>PRE 3. Search for information from various sources, including information and communication technologies to solve professional problems.</p> <p>PRE 4. Justify their own position, make independent conclusions based on the results of their own research and analysis of literary sources.</p> <p>PRE 5. Select and apply valid and reliable psychodiagnostic tools (tests, questionnaires, projective methods, etc.) for psychological research and psychological assistance technologies</p> <p>PRE 6. Formulate the goal, objectives of the study, master the skills of collecting primary material, follow the research procedure</p> <p>PRE 7. Reflect and critically evaluate the veracity of the results of psychological research, formulate reasoned conclusions</p> <p>PRE 8. Present the results of own research orally/written for specialists and non-specialists.</p> <p>PRE 9. Offer own ways to solve psychological tasks and problems in the process of professional activity, make and substantiate own decisions on their solution</p> <p>PRE 10. Formulate thoughts in a logical, accessible manner, debate, defend one's own position, and modify statements according to the cultural characteristics of the interlocutor</p> <p>PRE 11. Make and implement a plan for the consultation process, taking into account the specifics of the request and individual characteristics of the client, provide for the effectiveness of their own actions</p> <p>PRE 12. Develop and implement a program of psychoprophylactic and educational activities, psychological assistance measures in the form of lectures, conversations, round tables, games, trainings, etc. in accordance with the customer's requirements.</p> <p>PRE 13. Interacting, engaging in communication, being understood, and being tolerant of people with different cultural or gender-age differences.</p> <p>PRE 14. Effectively perform various roles in a team in the process of solving professional problems, including demonstrating leadership skills.</p> <p>PRE 15. Take a responsible attitude to professional self-improvement, training and self-development</p> <p>PRE 16. Know, understand and adhere to the ethical principles of professional activity of a psychologist</p> <p>PRE 17. Demonstrate socially responsible and conscious behavior, follow humanistic and democratic values in professional and social activities.</p> <p>PRE 18. Take effective measures to maintain health (own and others) and, if necessary, determine the content of the request for supervision</p>
	<p>8 – Resource support of program implementation</p>
<p>Staffing</p>	<ol style="list-style-type: none"> <li>1. Availability in the educational institution of a subdivision or chair responsible for the training of higher education applicants.</li> <li>2. In order to start educational activities: the presence of a project group responsible for the training of higher education applicants on a particular specialty which consists of research and teaching staff working at the main place of work: one Doctor of Science (Professor) and two Doctors of Philosophy / Associate Professor (Professor) of the appropriate</li> </ol>

	<p>specialty who have at least five years of experience in scientific and pedagogical work and have been conducting research on the appropriate specialty for the last five years.</p> <p>3. In order to implement educational activities: the availability of a project team responsible for the training of applicants of higher education on a particular specialty which consists of research and teaching staff working at the main place of work: one Doctor of Science (Professor) and two Doctors of Philosophy / Associate Professor (Professor) on the appropriate specialty for every hundred applicants.</p> <p>4. Carrying out training sessions by scientific and pedagogical (scientific) staff of the appropriate specialty at the main place of work (minimum percentage of the hours defined by the curriculum): 1) who have a scientific degree and / or academic title (until September 6, 2019 for the elementary level taking into account pedagogical workers who have a higher category) - 50; 2) who have a doctoral degree or academic title of professor - 10.</p> <p>5. Conducting lectures on academic disciplines that provide the formation of professional competencies by scientific and pedagogical (scientific) workers who are recognized professionals with experience in the specialty (minimum percentage of hours determined by the curriculum): research, innovation, management or creative work in the specialty - 10.</p> <p>6. Conducting lectures, practical, seminars and laboratory classes, carrying out scientific supervision of the course works, diploma works (projects), dissertation research by scientific and pedagogical (scientific) workers, the level of scientific and professional activity of each certified by the carrying out of at least three conditions specified in subparagraphs 1-16 of paragraph 5 of the notes of Annex 10 of the Licensing Conditions for the educational activities of educational institutions (Resolution of the Cabinet of Ministers of Ukraine of December 30, 2015 No. 1187)</p>
Logistical support	<p>1. Providing premises for conducting training and control activities (square meters per person for the licensed volume of students and the declared volume, taking into account training in shifts) (no more than two shifts are taken into account) - 2.4.</p> <p>2. Availability of multimedia equipment for simultaneous use in classrooms (minimum percentage of the number of classrooms) - 30.</p> <p>3. Availability of social infrastructure: 1) library, including a reading room; 2) catering facilities; 3) assembly or concert hall; 4) gym; 5) stadium and/or sports grounds; 6) medical center.</p> <p>4. Providing higher education students with a dormitory (minimum percentage of need) - 70.</p> <p>5. Availability of security service (in case of training of foreign citizens).</p> <p>6. Availability of passport and visa service for foreign citizens (in case of training of foreign citizens).</p> <p>7. Providing computer workstations, laboratories, testing grounds, equipment, facilities necessary for the implementation of curricula.</p>
Information and educational and methodological	<p>1. Providing the library with domestic and foreign professional periodicals of the relevant or related profile, including in electronic form: at least four titles.</p> <p>2. Availability of access to databases of periodical scientific publications in English of the relevant or related profile ( it is allowed joint use of databases by several educational institutions).</p>



support	<p>3. Availability of the official website of the educational institution which contains basic information about its activities (structure, licenses and certificates of accreditation, educational/educational-scientific/publishing/attestation (of scientific personnel) activities, educational and scientific structural units and their composition, list of disciplines, admission rules, contact information).</p> <p>4. Availability of an electronic resource of the educational institution, which contains teaching and methodological materials on the disciplines of the curriculum, including in the distance learning system (minimum percentage of disciplines) – 50</p> <p>5. Availability of educational program.</p> <p>6. Availability of the educational plan.</p> <p>7. Availability of a working program for each academic discipline of the curriculum.</p> <p>8. Availability of a set of educational and methodological support for each discipline of the curriculum.</p> <p>9. Availability of practical training program, work programs of practices.</p> <p>10. Providing students with teaching materials for each discipline of the educational plan.</p> <p>11. Availability of methodical materials for certification of applicants.</p>
9 – Academic mobility	
National credit mobility	Concluded agreement about cooperation and double certification with Colledge of linguistic in Czestochowa (Republic of Poland) which is included to the register of non-state educational institutions and association of non-state educational institutions on the basis of law dated 12 September 1990 on higher education
International credit mobility	-//-
Education of higher education foreign students	-//-

## 2. List of educational program components and their logic consequence

### 2.1. List of EP components

Code n/d	Components of educational and professional program (educational disciplines, course projects (works), practices, qualification work)	Amount of credits	Form of control
1	2	3	4
<b>Obligatory components of the EP</b>			
OK 1.1.1	Human anatomy and physiology of higher nervous activity	6	Exam
OK 1.1.2	Information technologies in education	3	Credit
OK 1.1.3	Basics of ecology	3	Credit
OK 1.1.4	History and culture of Ukraine	3	Exam
OK 1.1.5	Philosophy	3	Exam
OK 1.1.6	Ukrainian language for profesional purposes	3	Exam
OK 1.1.7	Basics of life safety and human's health	3	Credit
OK 2.1.1	Pedagogy	9	Exam
OK 2.1.2	Zoopsychoology and comparative psychology	3	Credit

OK 2.1.3	Introduction to the specialty	3	Credit
OK 2.1.4	General psychology with workshop	12	Exam
OK 2.1.5	Trenning-course of conversation	9	Credit
OK 2.1.6	Training course of motivation and self-knowledge	9	Credit
OK 2.1.7	Mental hygiene	3	Exam
OK 2.1.8	Age and educational psychology	6	Exam
OK 2.1.9	Mathematical statistics and mathematical methods in psychology	3	Credit
OK 2.1.10	Course work on age psychology	3	
OK 2.1.11	Course work on experimental psychology	3	
OK 2.1.12	Experemental psychology and psychodiagnostics	7	Exam
OK 2.1.13	Clinical psychology	3	Exam
OK 2.1.14	Differential psychology	3	Exam
OK 2.1.15	Social psychology (Ethnopsychology)	3	Exam
OK 2.1.16	Psychology of management	3,5	Credit
OK 2.1.17	Social psychology	3	Exam
OK 2.1.18	Psychotherapy	3	Exam
OK 2.1.19	A psychological service in the system of education	4	Exam
OK 2.1.20	Психологія творчості і обдарованості	3,5	Exam
OK 2.1.21	Основи психологічного консультування та психокорекції з практикумами	20	Credit
OK 2.1.22	History of psychology	3	Exam
OK 2.1.23	Basics of scientific research	3	Credit
OK 3.1.1	Introductory practice (continuous)	4,5	Credit
OK 3.1.2	Educational practice (in summer health camps)	4,5	Credit
OK 3.1.3	Psychodiagnostic practice (industrial)	6	Credit
OK 3.1.4	Psycho-correctional and psycho-counseling practice	9	Credit
OK 3.1.5	Foreign language with a workshop	5	Exam
OK 4.1.1	Final certification: Comprehensive exam in psychology	2	Exam
OK 4.1.2	Final certification : Bachelor's work	2	Exam
<b>General amount of obligatory components</b>		<b>179</b>	
<i>Selective educational disciplines of the general training cycle</i>			
1ББ 1.2.1	Ethology	3	Credit
1ББ 1.2.2.	Fundamentals of demography		Credit
1ББ 1.2.3.	Anthropology		Credit
1ББ 1.2.4	Innovative technologies in education	3	Credit
1ББ 1.2.5	Fundamentals of entrepreneurial activity		Credit
1ББ 1.2.6	Political science		Credit
1ББ 1.2.7	Fundamentals of jurisprudence		Credit
1ББ 1.2.8	Sociology		Credit
1ББ 1.2.9	Logic		Credit
1ББ 1.2.10	Ethics and aesthetics		Credit
1ББ 1.2.11	Religious studies		Credit
1ББ 1.2.12.	Basics of economic theory		Credit
1ББ 1.2.13.	Basics of management of Ukrainian education		Credit

1ББ 1.2.14.	German language	3	Credit
1ББ 1.2.15.	Basics of ecological culture		Credit
1ББ 1.2.16.	Quality culture of higher education		Credit
1ББ 1.2.17.	Basics of anti-terrorist protection		Credit
1ББ 1.2.18	Discipline from another EP		Credit
<b><i>Selective educational disciplines of the profesuional training cycle</i></b>			
2ББ 2.2.1.	Preschool psychology	4	Exam
2ББ 2.2.2.	Sexology and gender psychology	4	Exam
2ББ 2.2.3.	Engineering psychology		Exam
2ББ 2.2.4.	Psychology of adolescence		Exam
2ББ 2.2.5.	Psychology of non-verbal means of communication	4	Credit
2ББ 2.2.6.	Economic psychology		Credit
2ББ 2.2.7.	Legal psychology	4	Exam
2ББ 2.2.8.	Psychology of health		Exam
2ББ 2.2.9.	Psychology of work and choice of profession	4	Credit
2ББ 2.2.10.	Theories of personality	4	Credit
2ББ 2.2.11.	Psychology of sport		Credit
2ББ 2.2.12.	Basics of manual labor		Credit
2ББ 2.2.13.	Psychology of mass media	4	Credit
2ББ 2.2.14.	Psychology of primary school age		Credit
2ББ 2.2.15.	Self-organization of personality	4	Exam
2ББ 2.2.16.	Computer processing of research data	4	Exam
2ББ 2.2.17.	Psychology of deviant behavior	4	Exam
2ББ 2.2.18.	Psychodiagnostics in the education system		Exam
2ББ 2.2.19.	Life crises of personality		Exam
2ББ 2.2.20.	Military psychology		Exam

2ББ 2.2.21.	Basics of defectology and speech therapy	4	Credit
2ББ 2.2.22.	Psychology of personal information security	4	Credit
2ББ 2.2.23.	Basics of transactional analysis	4	Credit
2ББ 2.2.24.	Psychology of the Internet		Credit
2ББ 2.2.25.	Psychology of health		Credit
2ББ 2.2.26.	Psychology of production		Credit
<b>General amount of selective components</b>		<b>61</b>	
<b>GENERAL AMOUNT OF THE EDUCATIONAL PROGRAM</b>		<b>240</b>	

## 2.2. Structural and logical scheme of the EP

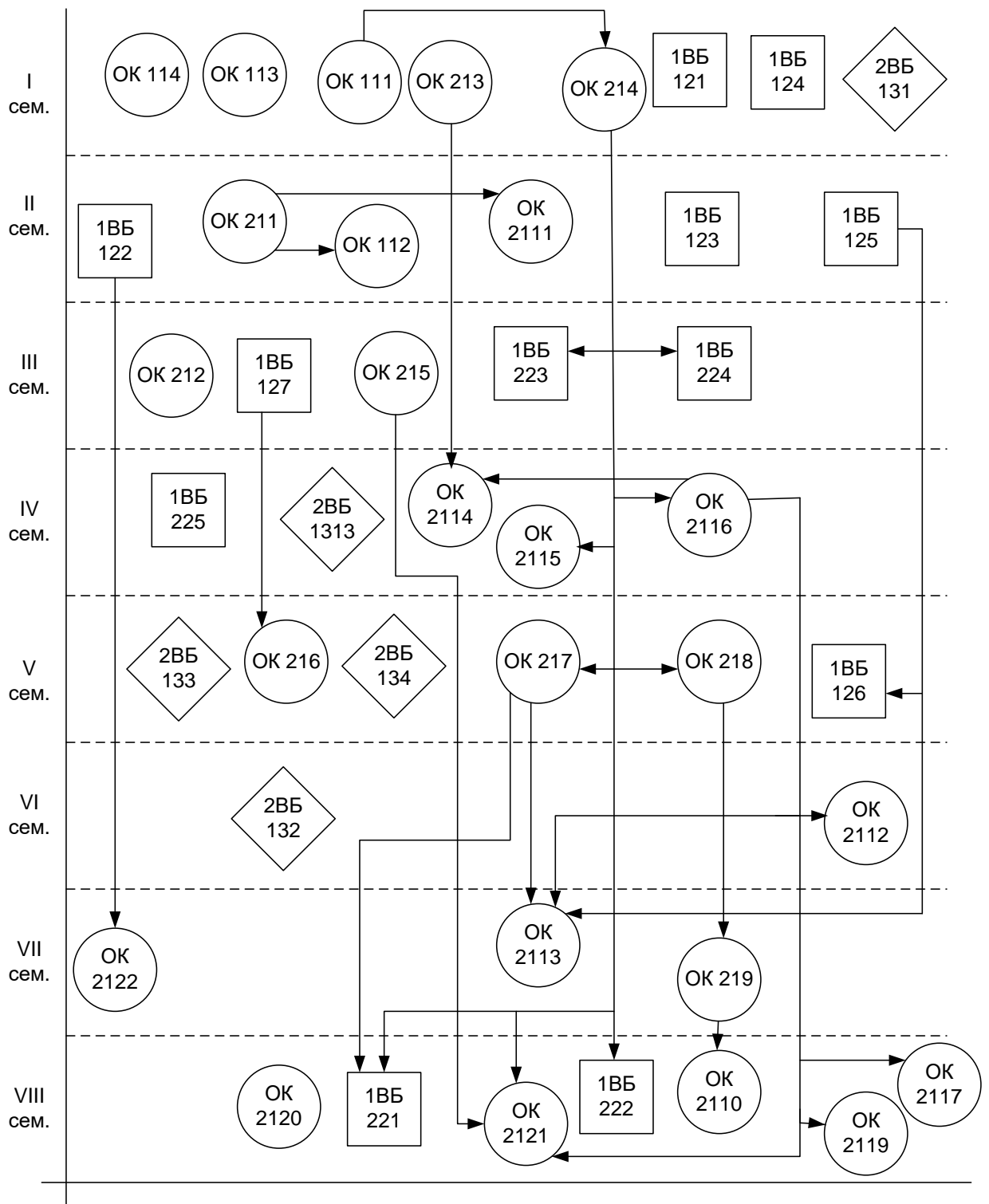

Symbols of educational program components:

- - obligatory components of the EP
- - components of selective block 1 (choice of educational institution)
- ◇ - components of selective block 2 (student's choice)

Code of academic disciplines - according to the table in paragraph 2.1.

**3. Form of students certification**

The final state certification of graduates of the educational program of specialty 053 "Psychology" is carried out in the form of comprehensive exam in psychology and public defense of qualifying work and ends with issuance of a document of the established sample on awarding a bachelor degree with the qualification "Psychology".

#### 4. Conformity matrix of program competences to the components of educational program

##### 4.1. Obligatory components of the EP

	3 К 1	3 К 2	3К 3	3 К 4	3 К 5	3 К 6	3 К 7	3К 8	3 К 9	3 К 10	3 К 11	Φ К 1	Φ К 2	Φ К 3	Φ К 4	Φ К 5	Φ К 6	Φ К 7	Φ К 8	Φ К 9	Φ К 10	Φ К 11	
OK 1.1.1	+												+	+				+					
OK 1.1.2			+				+																
OK 1.1.3	+									+													
OK 1.1.4										+	+												
OK 1.1.5	+			+	+						+												
OK 1.1.6				+				+	+	+	+												
OK 1.1.7	+			+																			
OK 2.1.1		+		+								+											
OK 2.1.2		+												+									
OK 2.1.3											+											+	+
OK 2.1.4						+						+	+	+									
OK 2.1.5	+							+											+		+	+	+
OK 2.1.6	+				+		+												+		+	+	+
OK 2.1.7												+		+					+	+			
OK 2.1.8	+											+	+			+							
OK 2.1.9																+	+	+					
OK 2.1.10			+	+	+		+									+	+	+					
OK 2.1.11			+	+	+		+									+	+	+					
OK 2.1.12			+		+	+	+							+	+	+		+					+
OK		+												+		+			+				



1.1.4																		
OK 1.1.5			+	+				+		+								
OK 1.1.6				+				+		+			+					
OK 1.1.7																	+	+
OK 2.1.1		+		+						+			+		+			
OK 2.1.2	+								+									
OK 2.1.3													+	+	+	+	+	
OK 2.1.4	+	+	+						+						+			
OK 2.1.5									+	+					+		+	
OK 2.1.6									+	+					+		+	
OK 2.1.7		+															+	+
OK 2.1.8	+	+							+				+		+			
OK. 2.1.9	+					+	+	+	+									
OK. 2.1.10	+	+				+	+	+	+	+	+					+		
OK 2.1.11	+	+				+	+	+	+	+	+					+		
OK 2.1.12	+			+	+	+	+	+	+									
OK 2.1.13	+	+										+					+	+
OK 2.1.14	+	+				+							+					
OK 2.1.15	+	+											+				+	
OK 2.1.16	+	+											+	+			+	
OK 2.1.17	+	+							+				+	+			+	
OK 2.1.18	+	+						+		+		+	+			+	+	+
OK 2.1.19													+	+	+	+	+	+
OK 2.1.20	+	+				+							+					
OK 2.1.21	+	+				+			+		+	+			+	+		+
OK 2.1.22	+			+	+			+			+							



OK 2.1.23				+	+	+	+	+		+									
OK 3.1.1			+	+					+					+	+	+		+	
OK 3.1.2										+				+	+	+	+	+	+
OK 3.1.3	+	+	+	+	+	+	+	+	+	+					+		+		
OK 3.1.4	+	+	+	+	+	+	+	+	+	+	+	+			+		+		
OK 3.1.5			+	+										+		+			
OK 4.1.1	+	+	+	+	+	+	+	+	+	+	+	+	+	+	+	+	+	+	+
OK 4.1.2	+	+	+	+	+	+	+	+	+	+		+					+		