

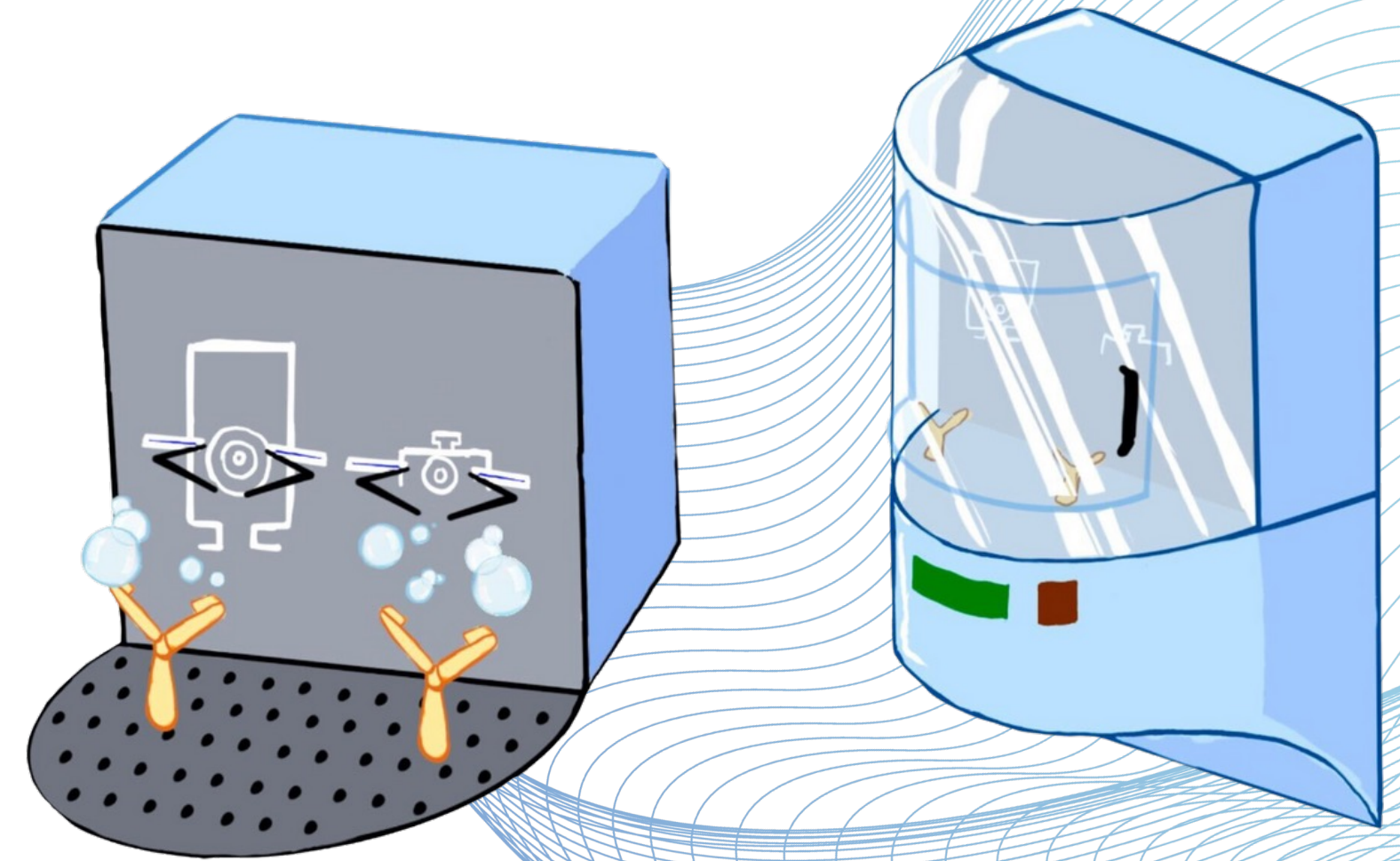

2.009 Blue Team

SAFE2SIP

a new way of clean for your water bottle







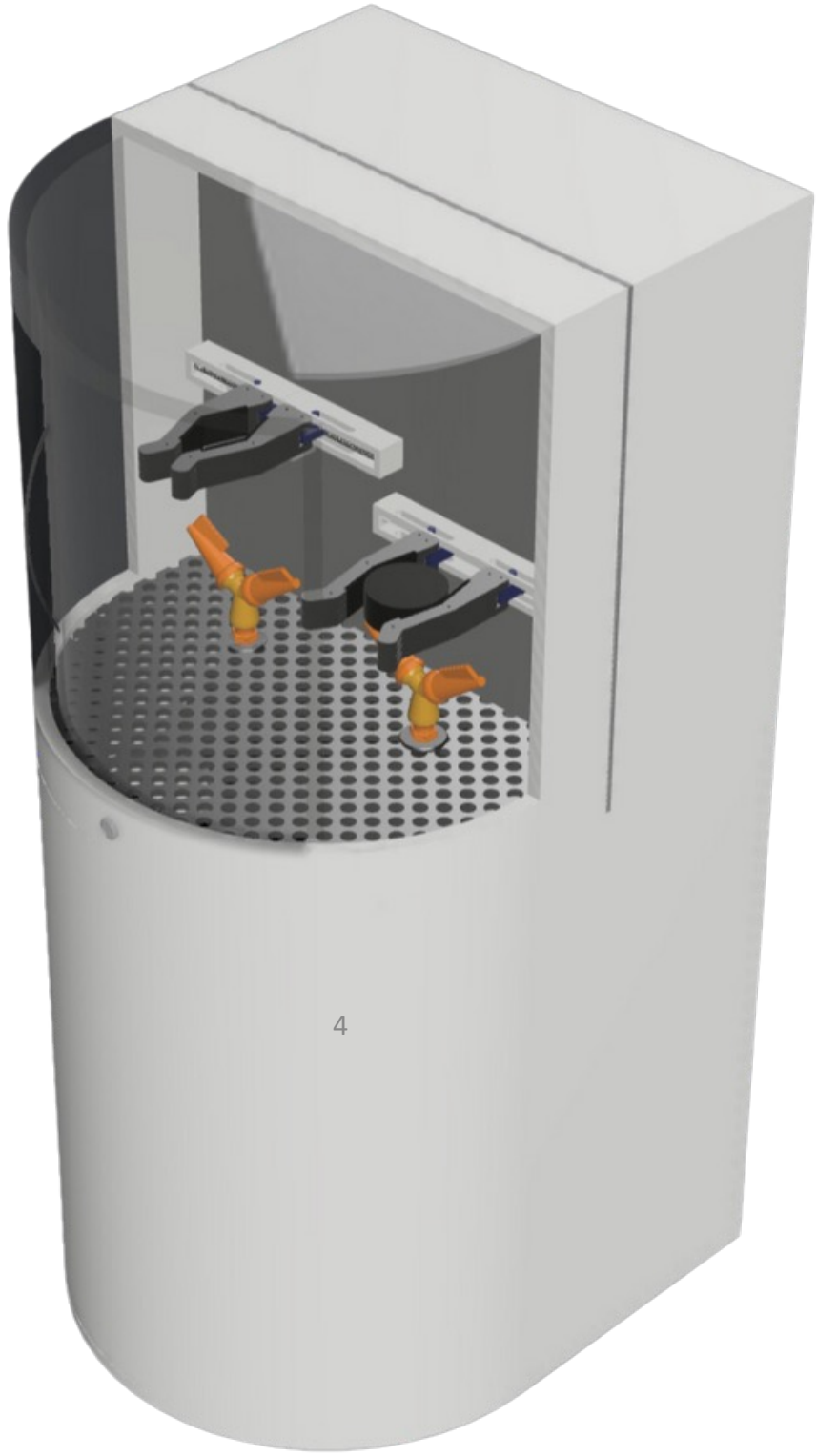

4

housing

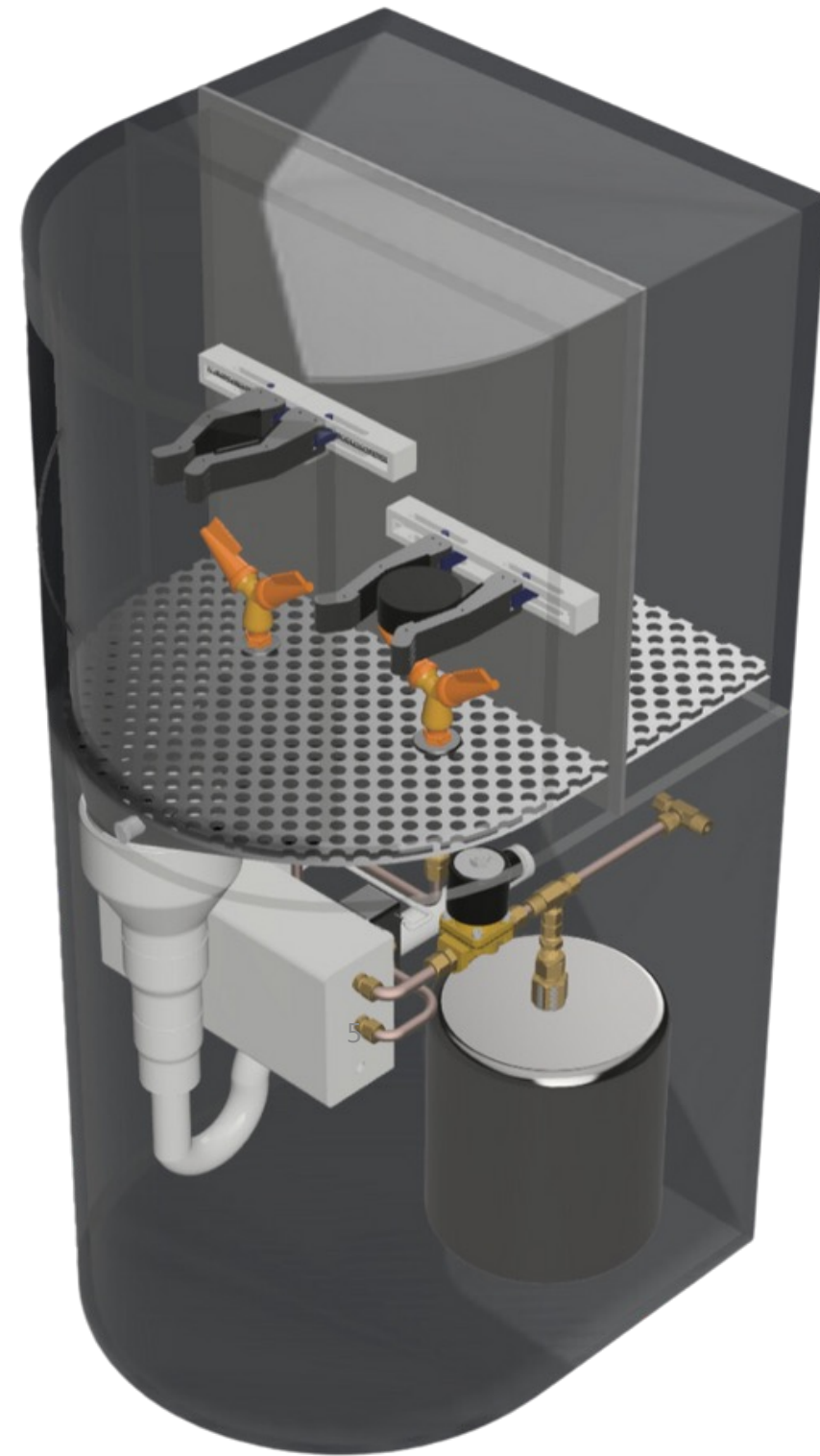

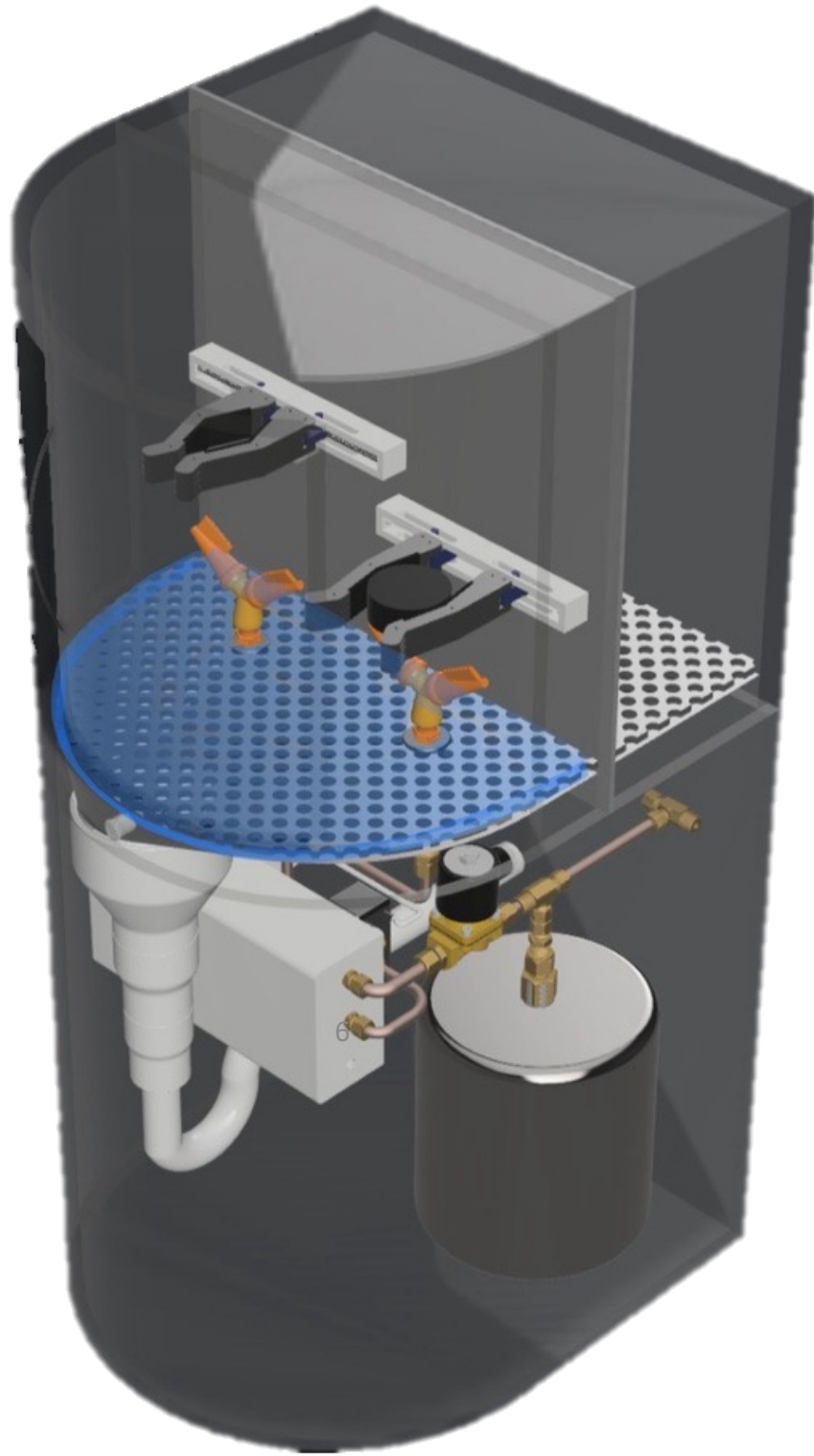

housing
drainage

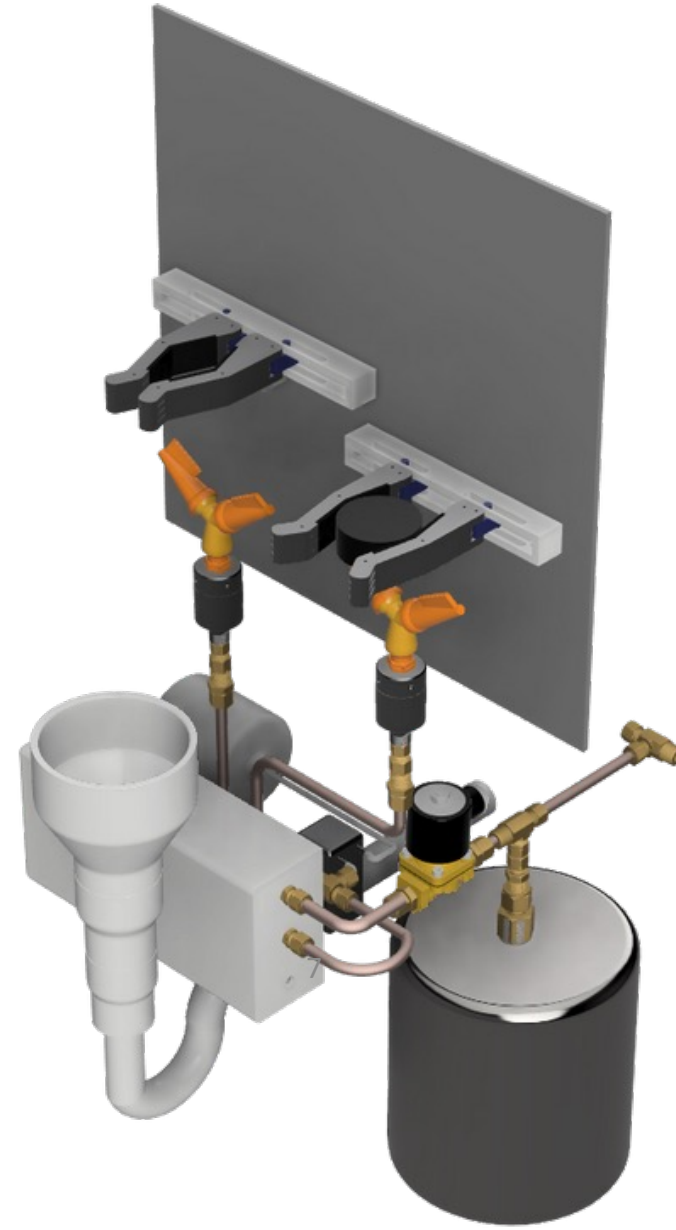

housing
drainage
electronics

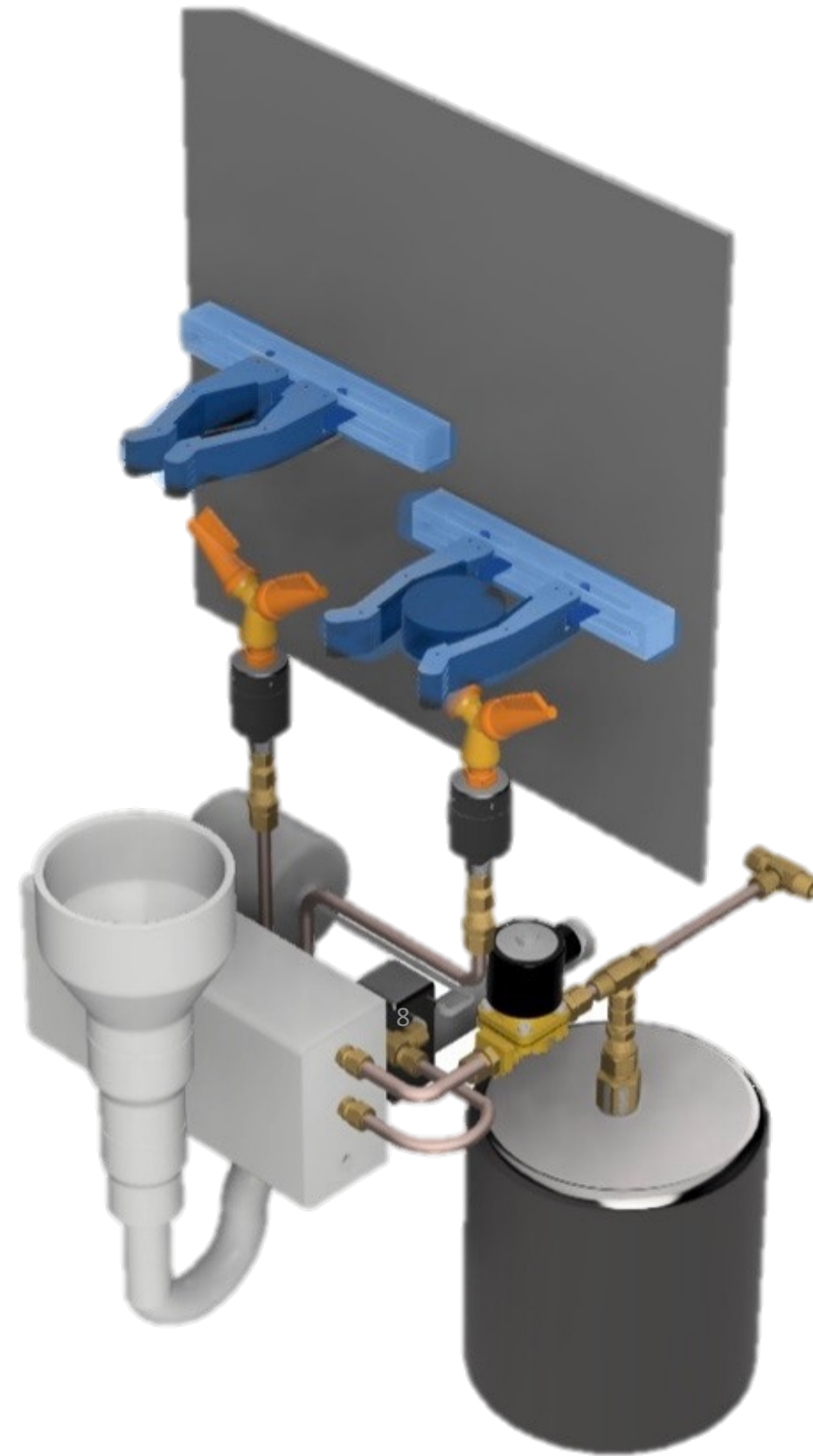

housing

drainage

electronics

clamping

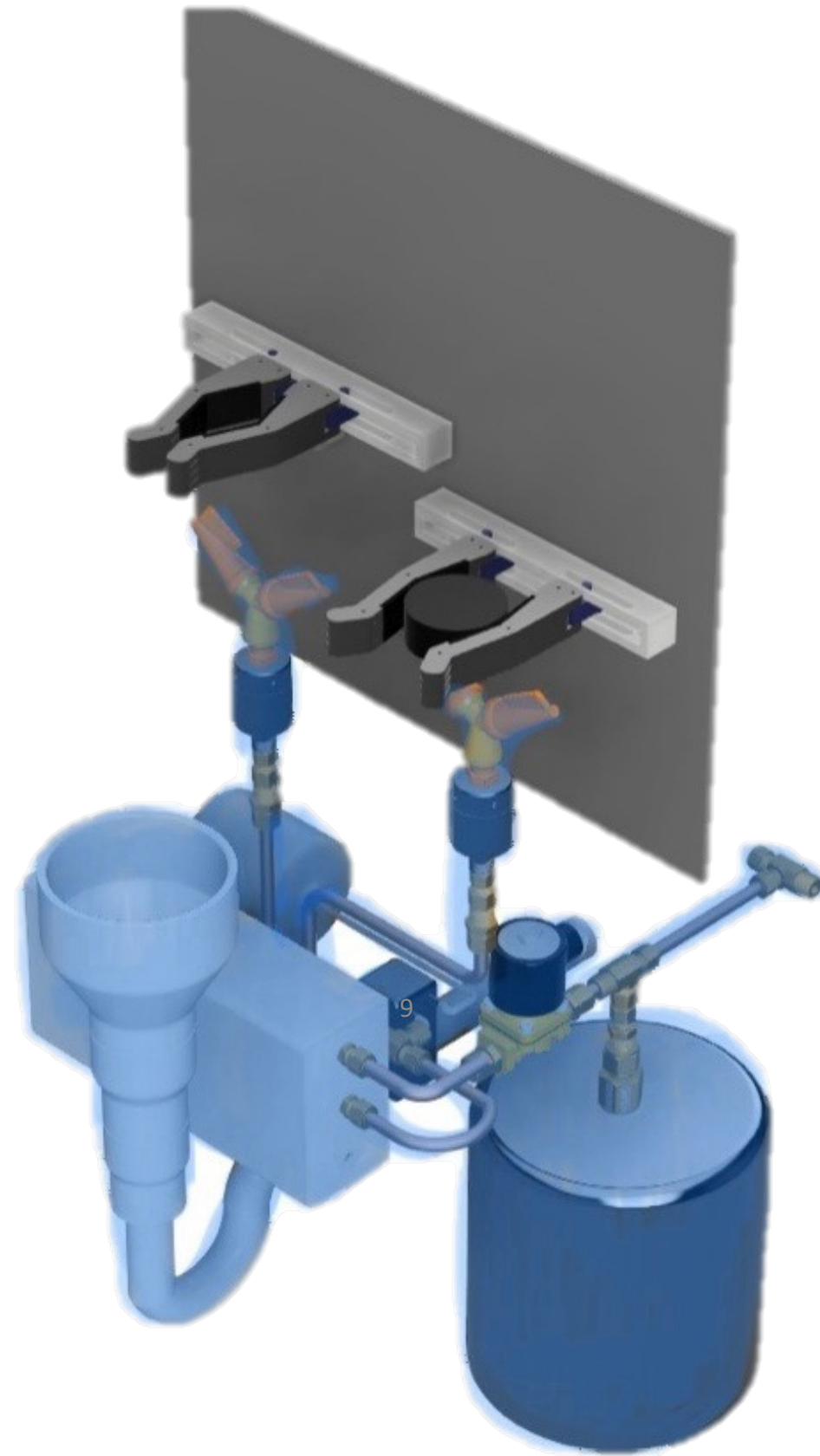

housing

drainage

electronics

clamping

cleaning

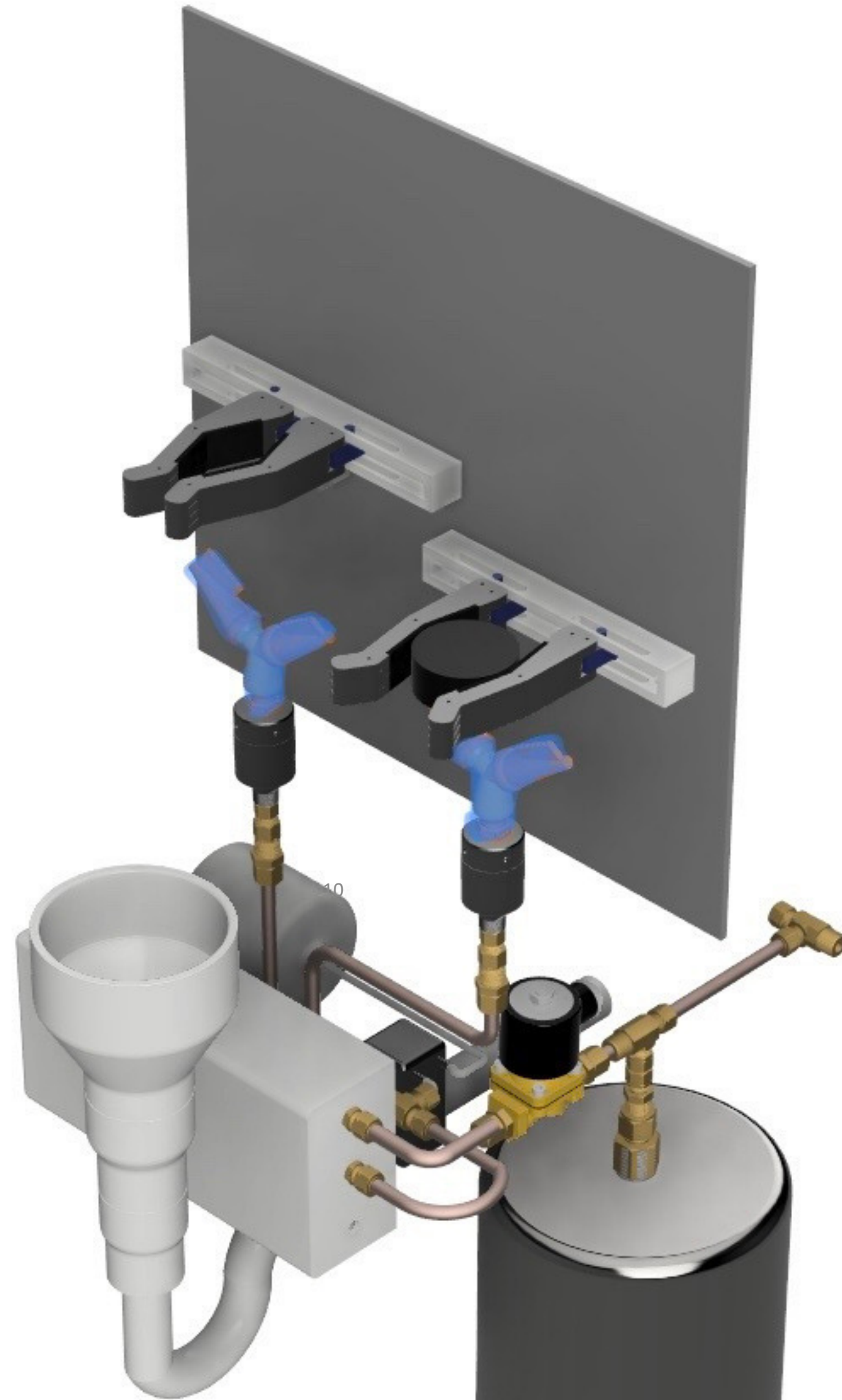

housing

drainage

electronics

clamping

cleaning

nozzle

BOTTLE INTERFACE

11

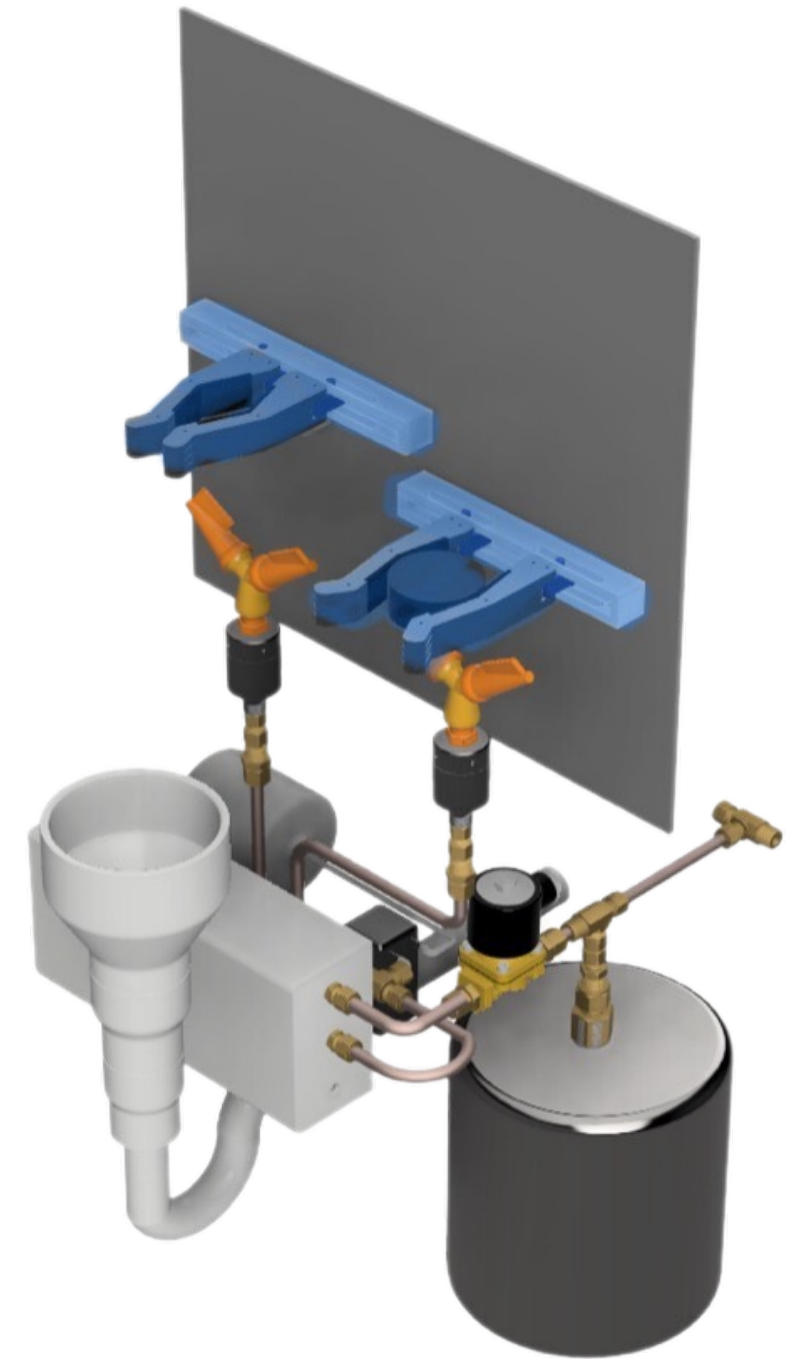

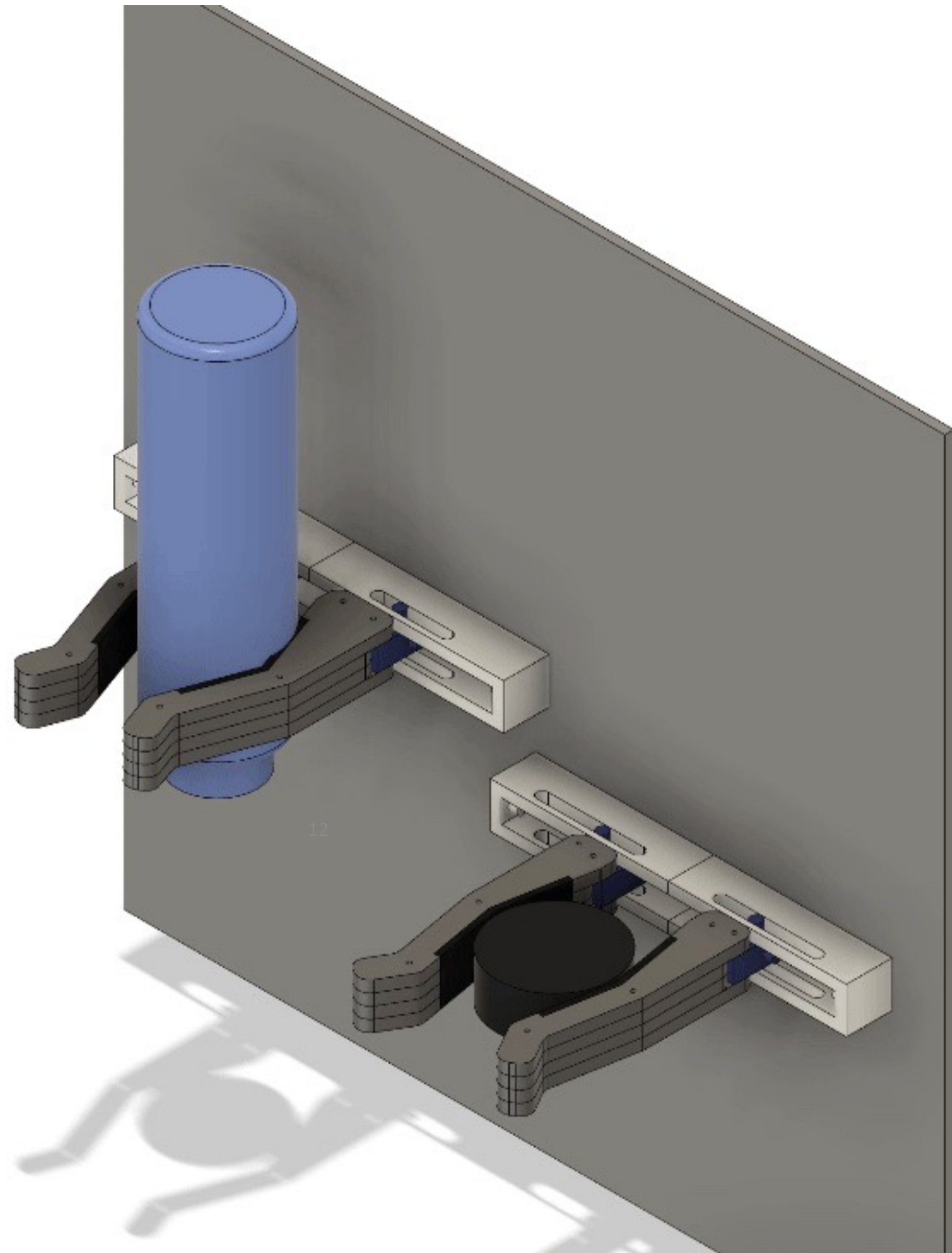

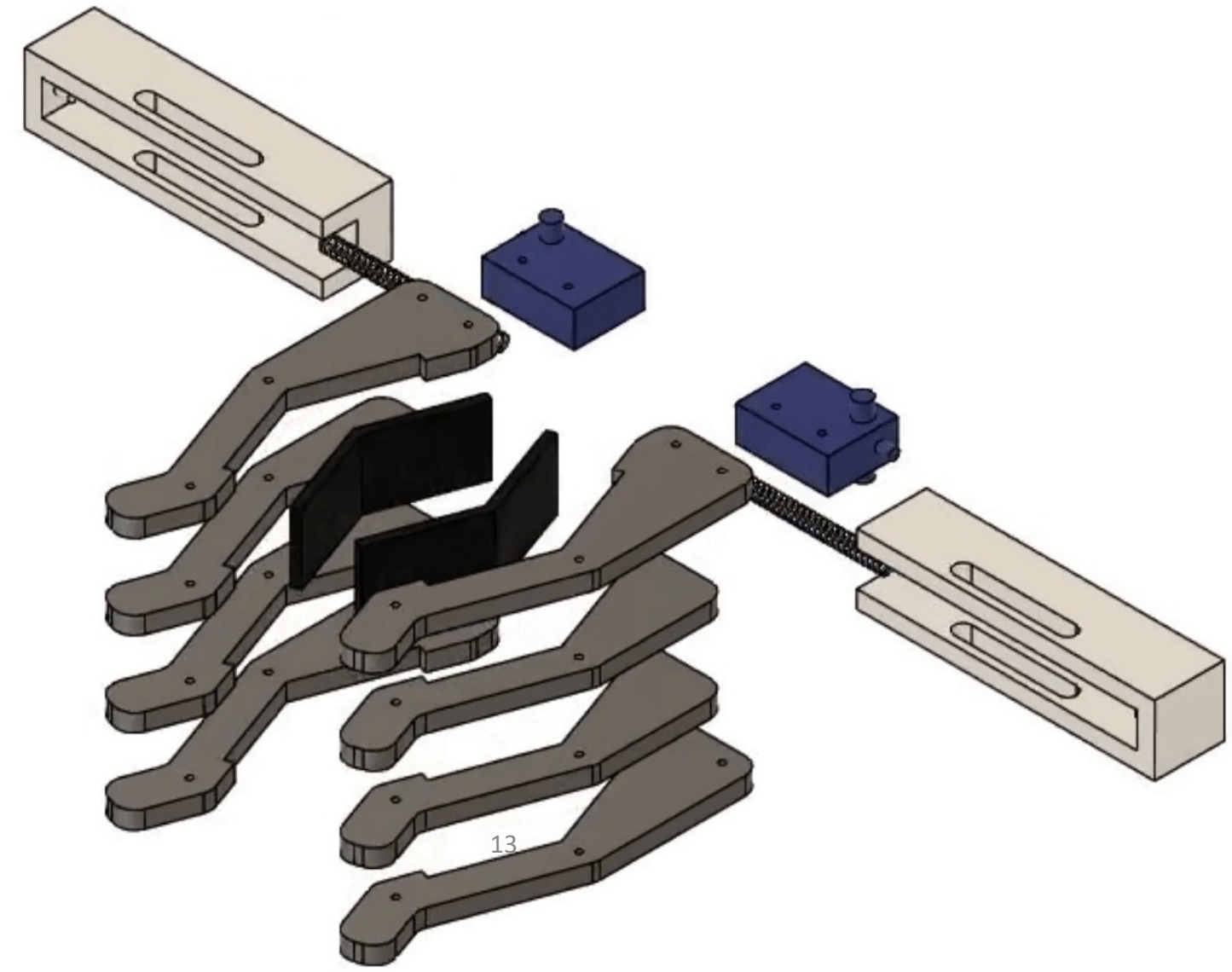

13

CLEANING PROCESS

14

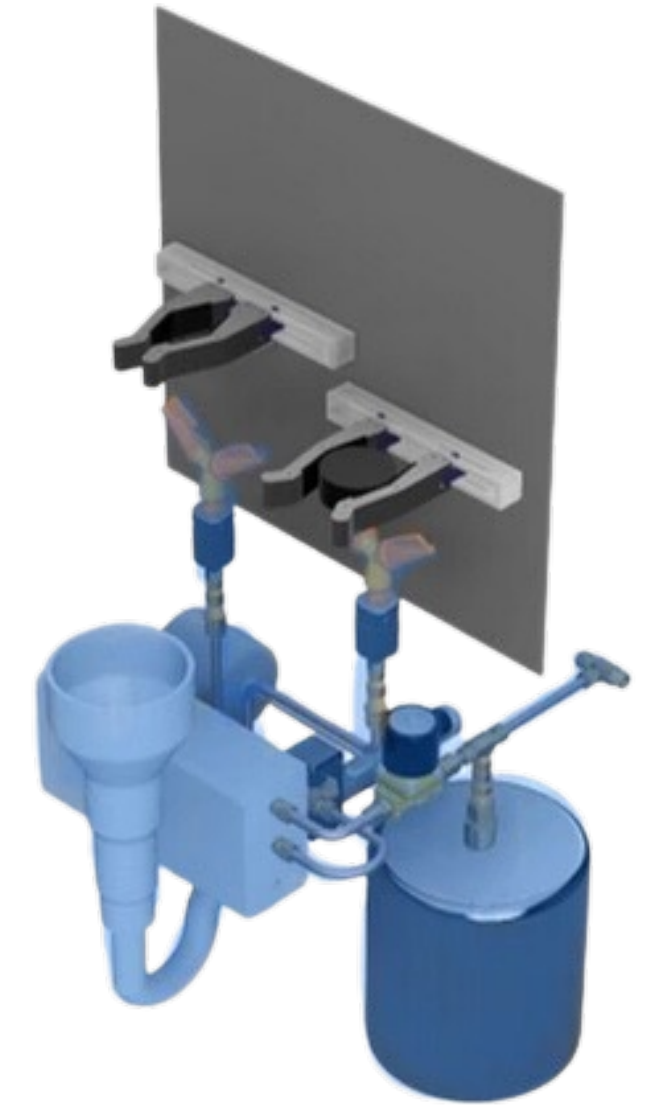

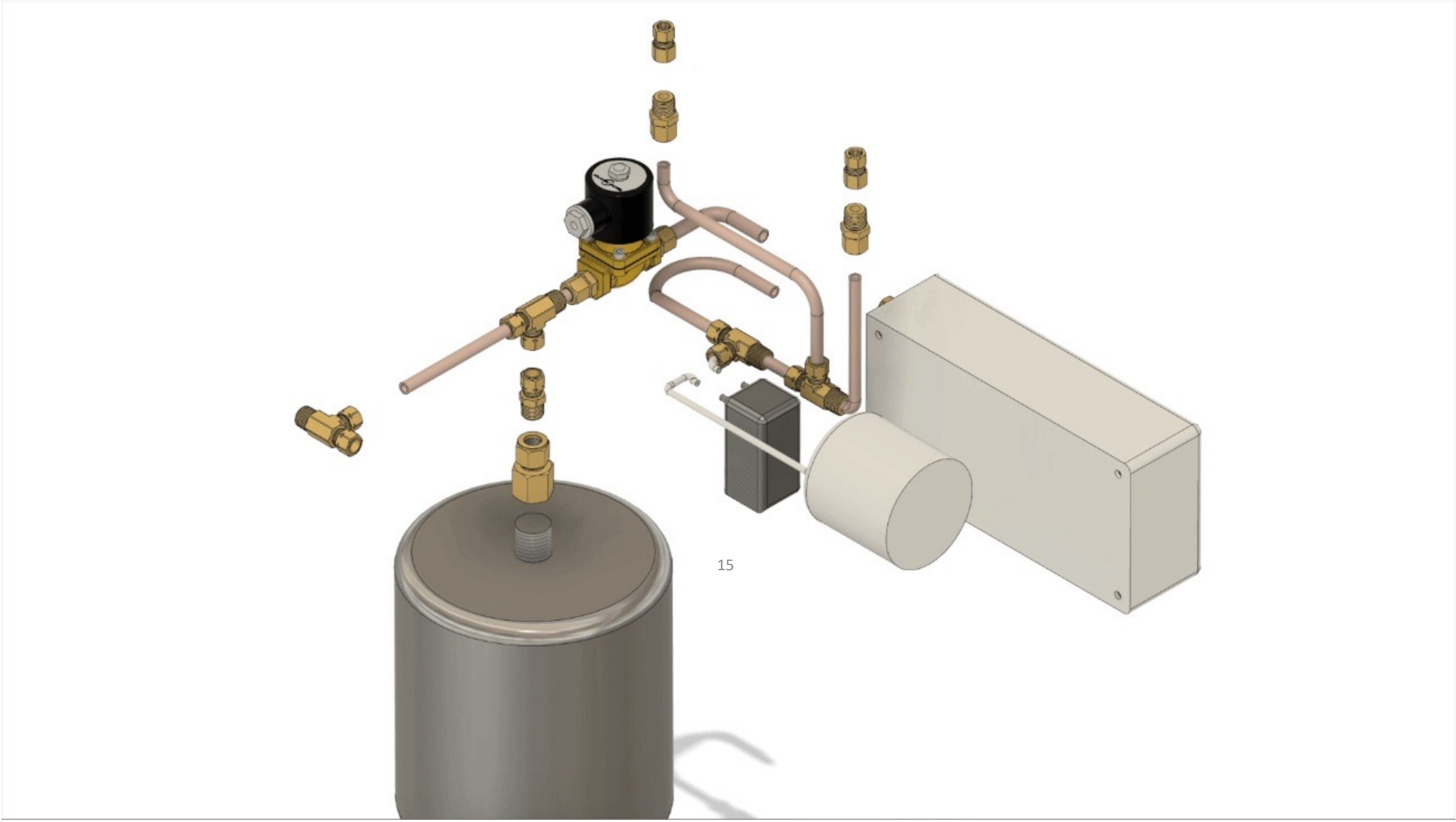

15

water supply

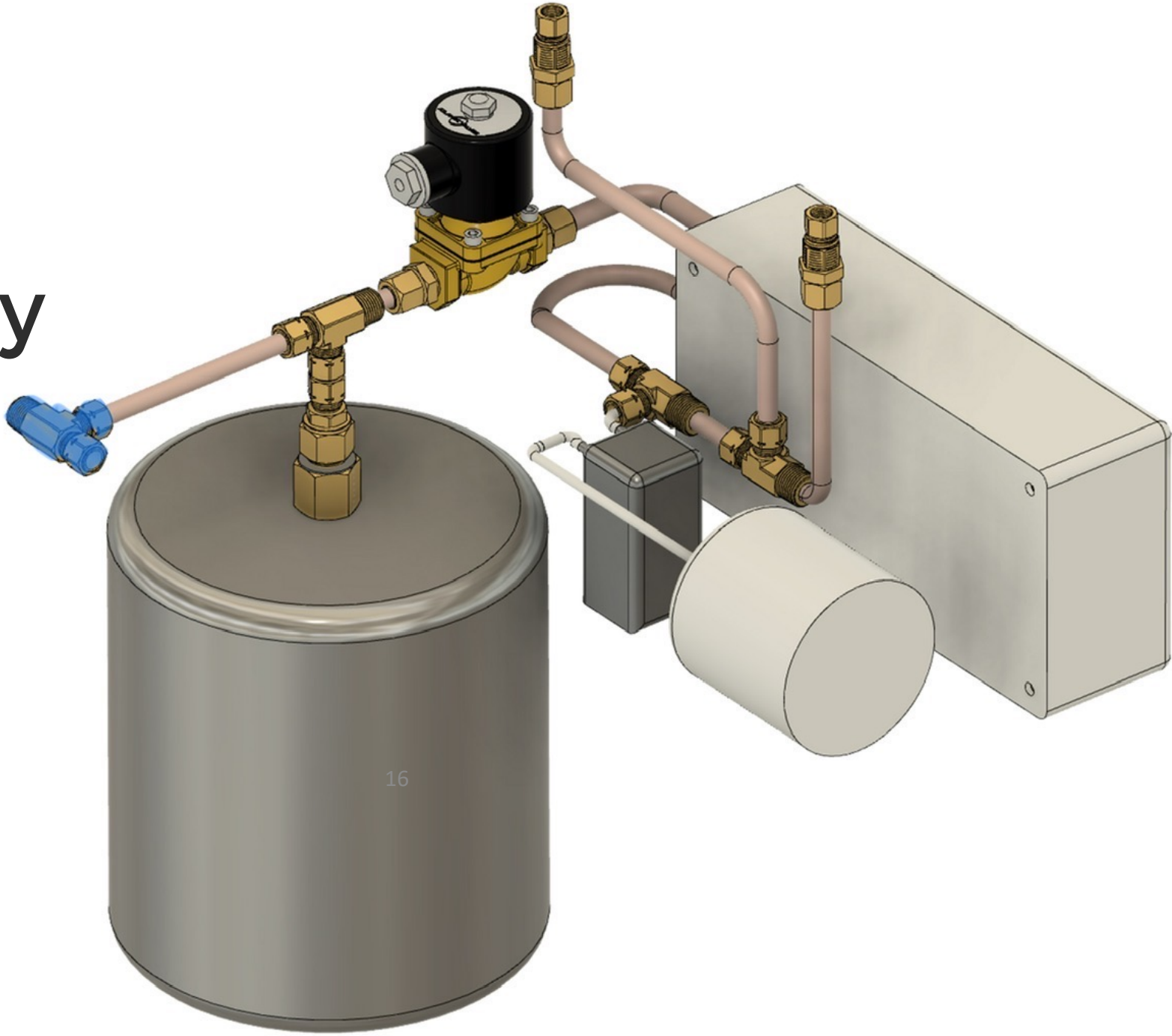

16

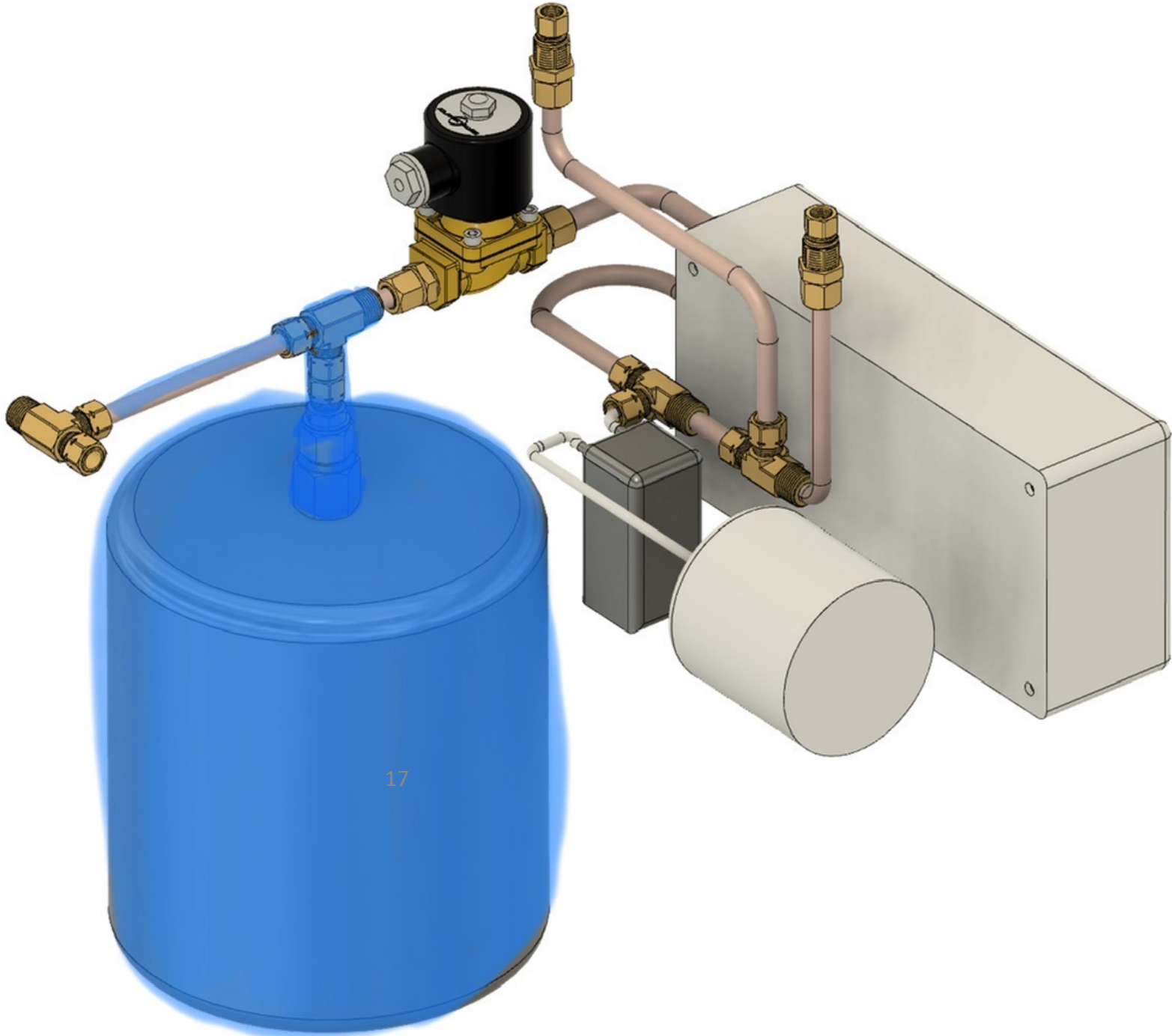

accumulator

solenoid valve

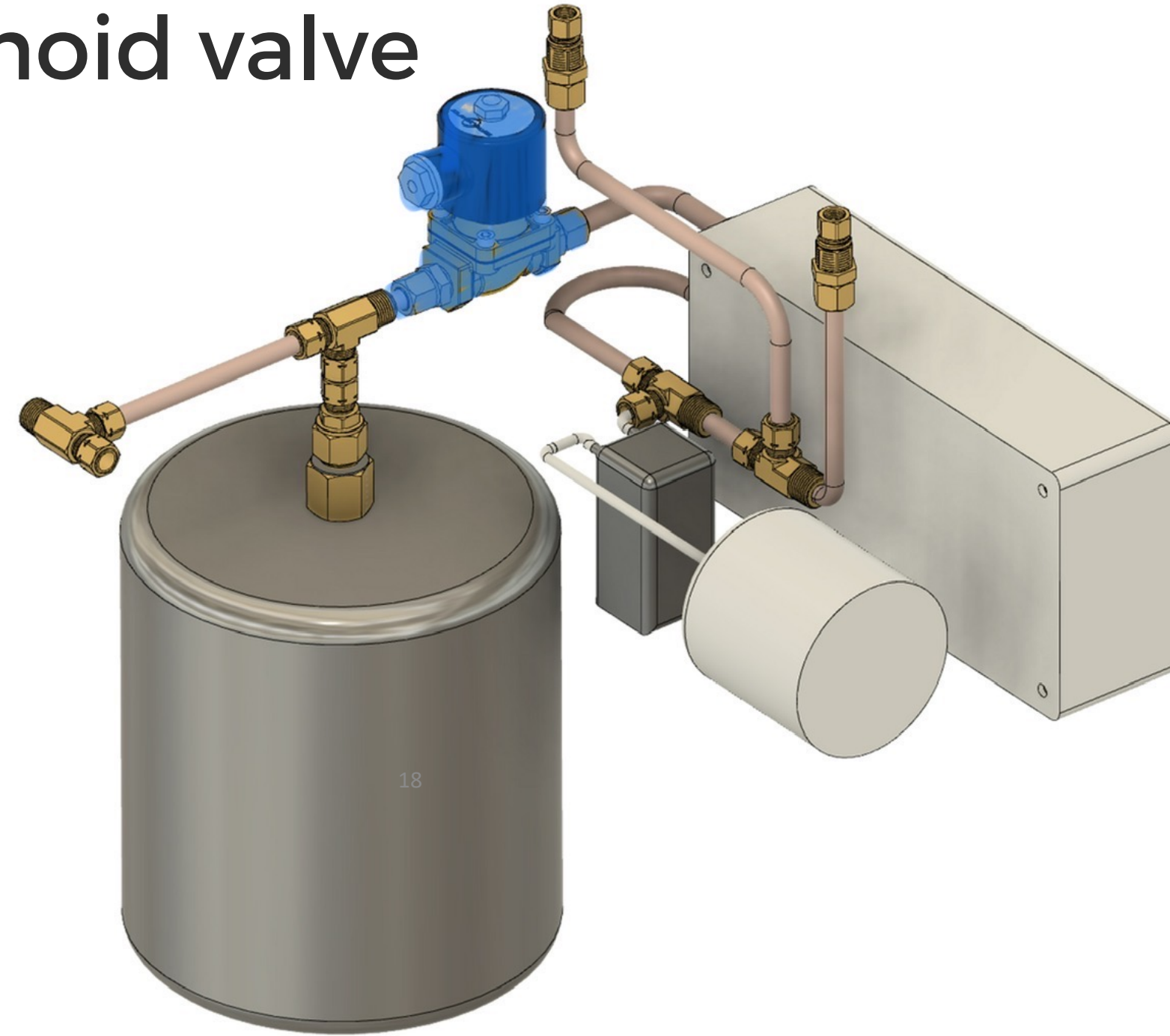

18

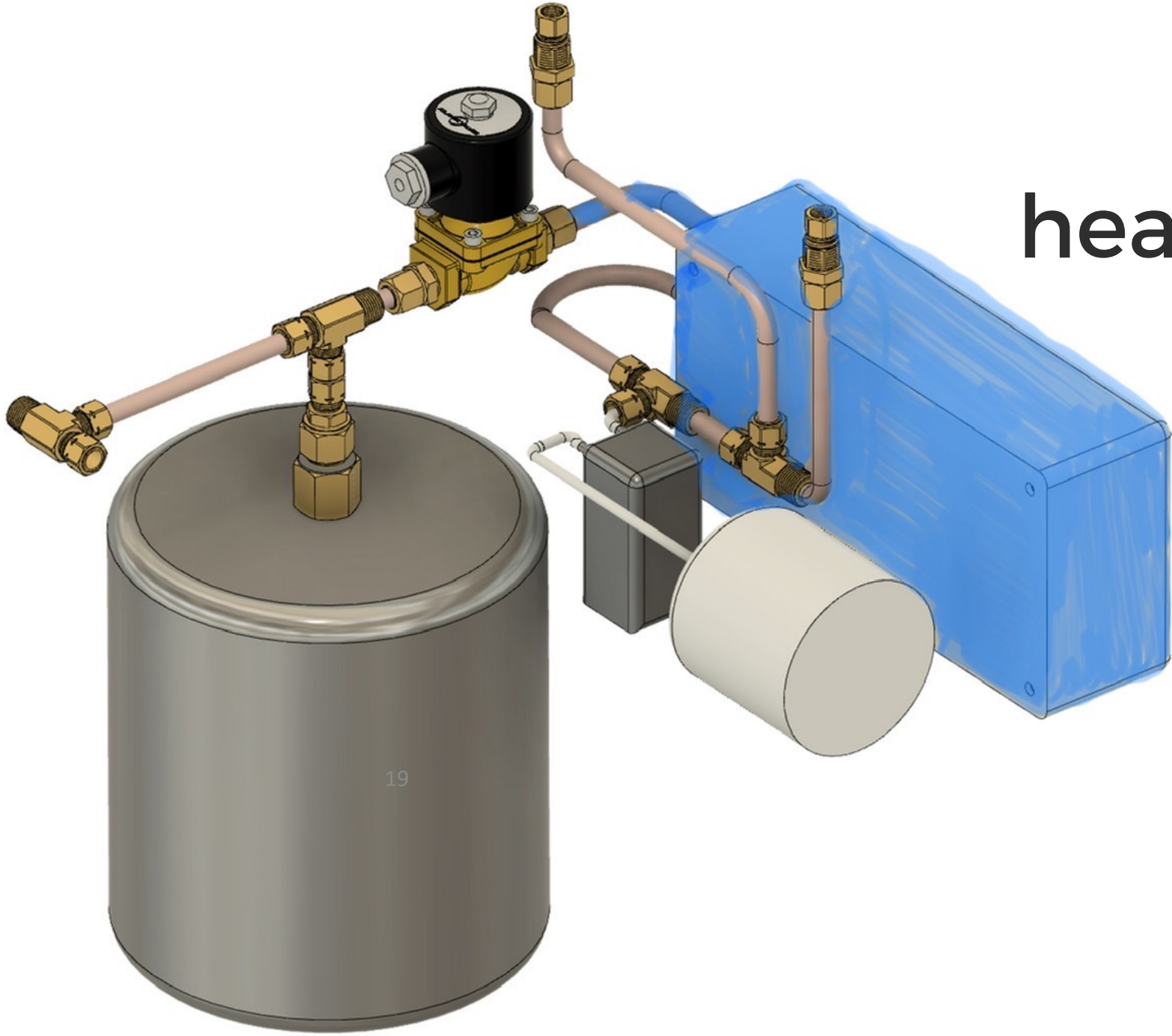

heater

19

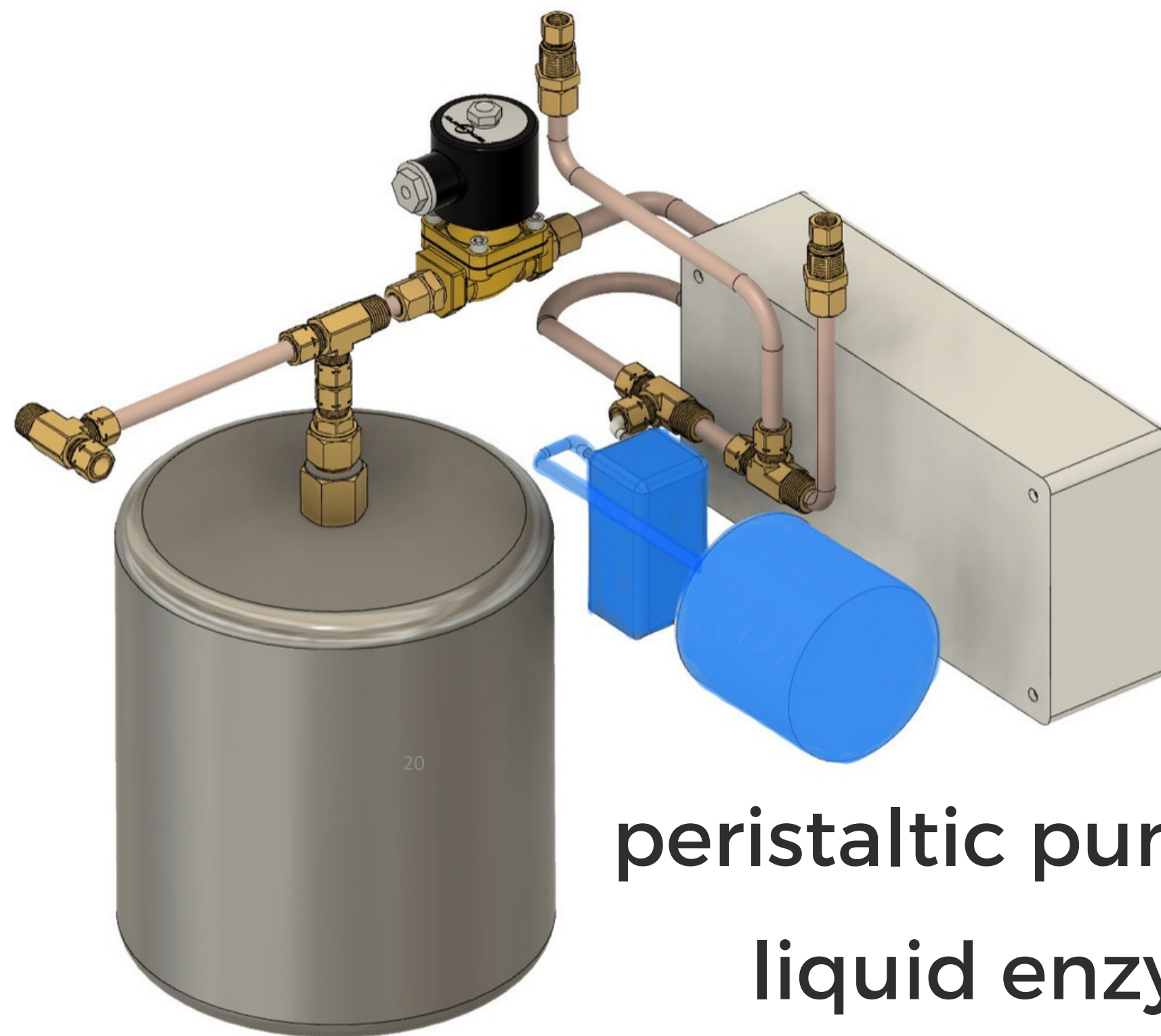

peristaltic pump

liquid enzyme detergent

NOZZLE DESIGN

21

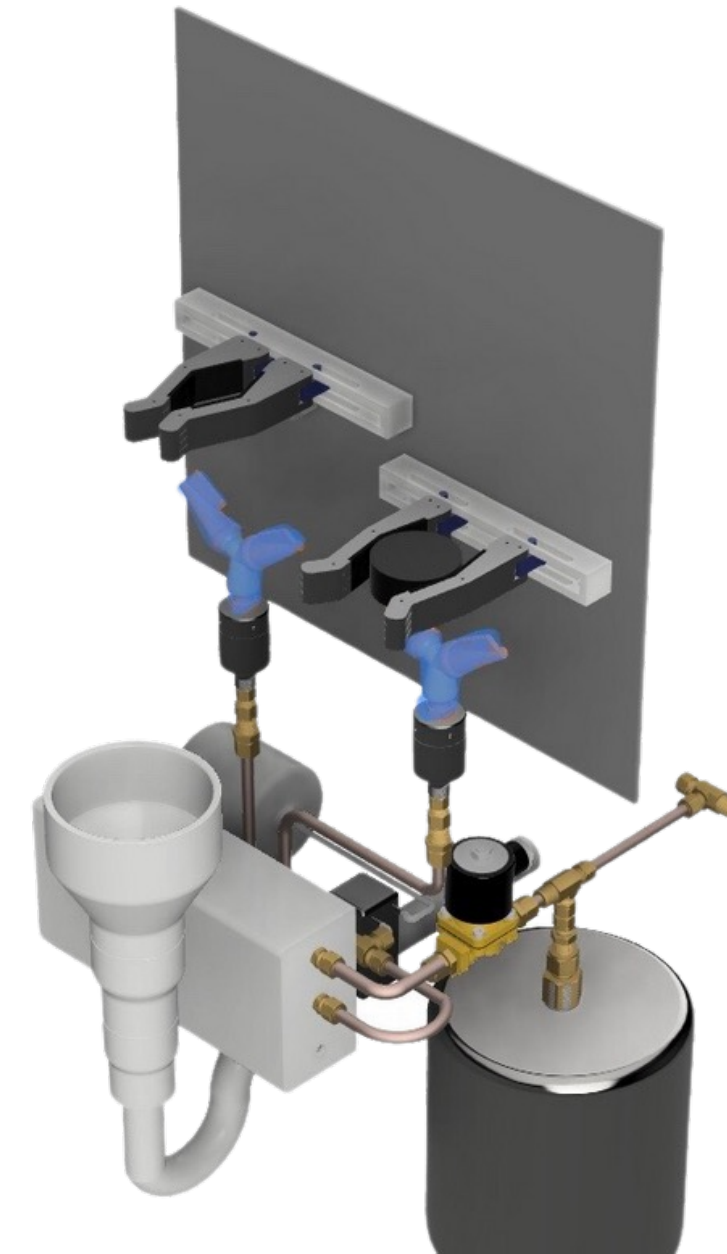

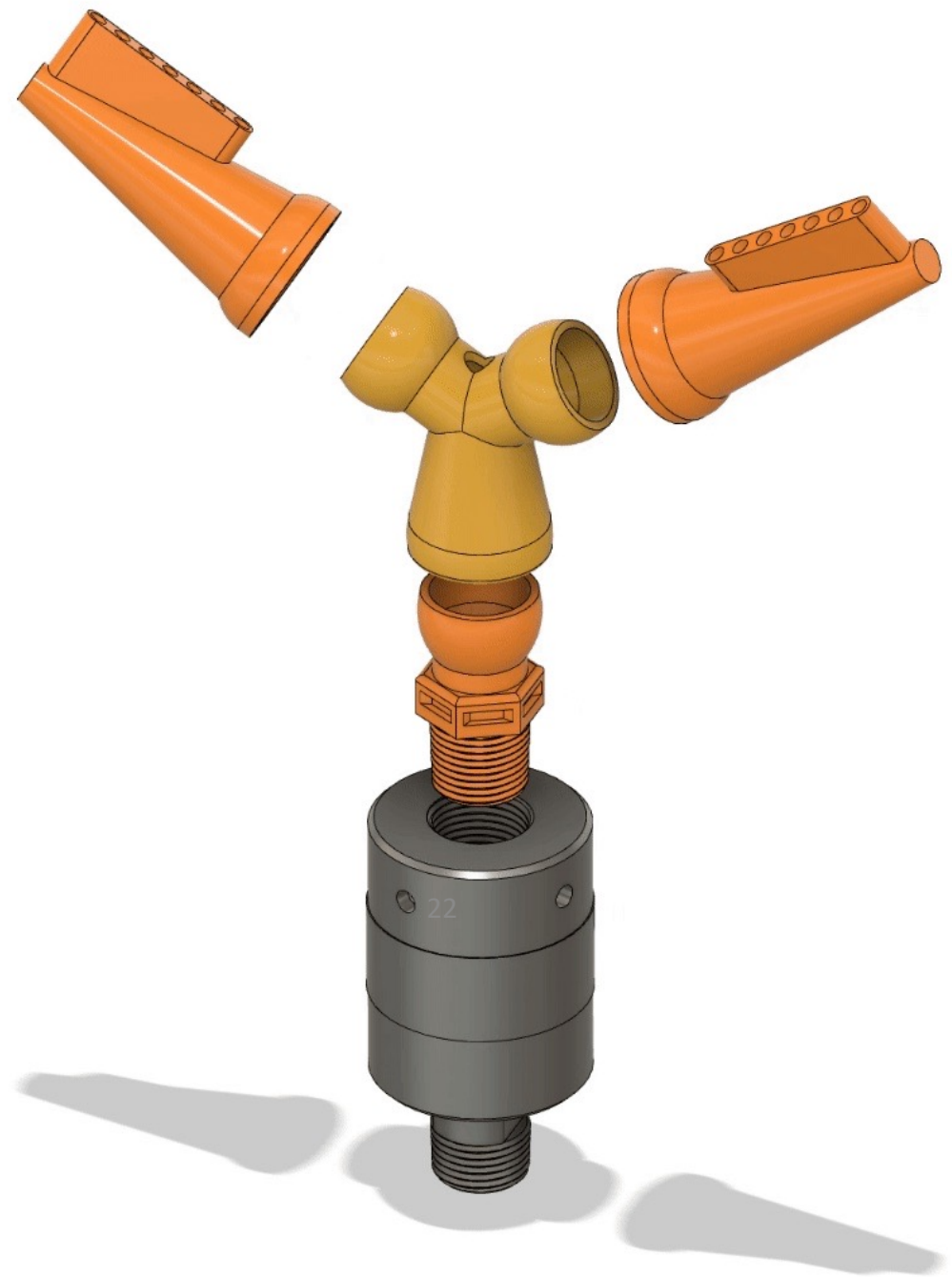

COOLING RINSE

23

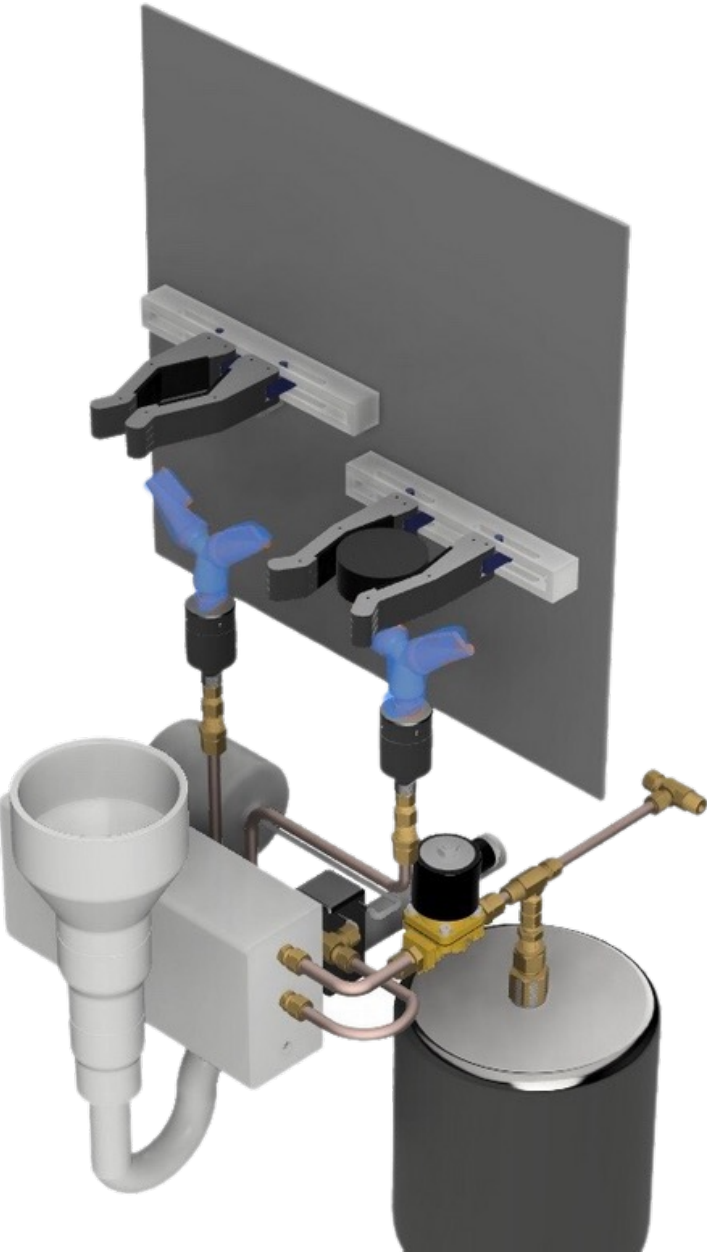

Room temperature water rinse for ~5s is sufficient to cool the bottle down.

Cooling by Fans 20s to cool from 135F to 120F

Air Cooling 25-45s to cool from 135F to 120F

Cool Water Rinse ~7s rinse to cool the bottle from 123F to 108F

DRAINING

25



ELECTRONICS

27

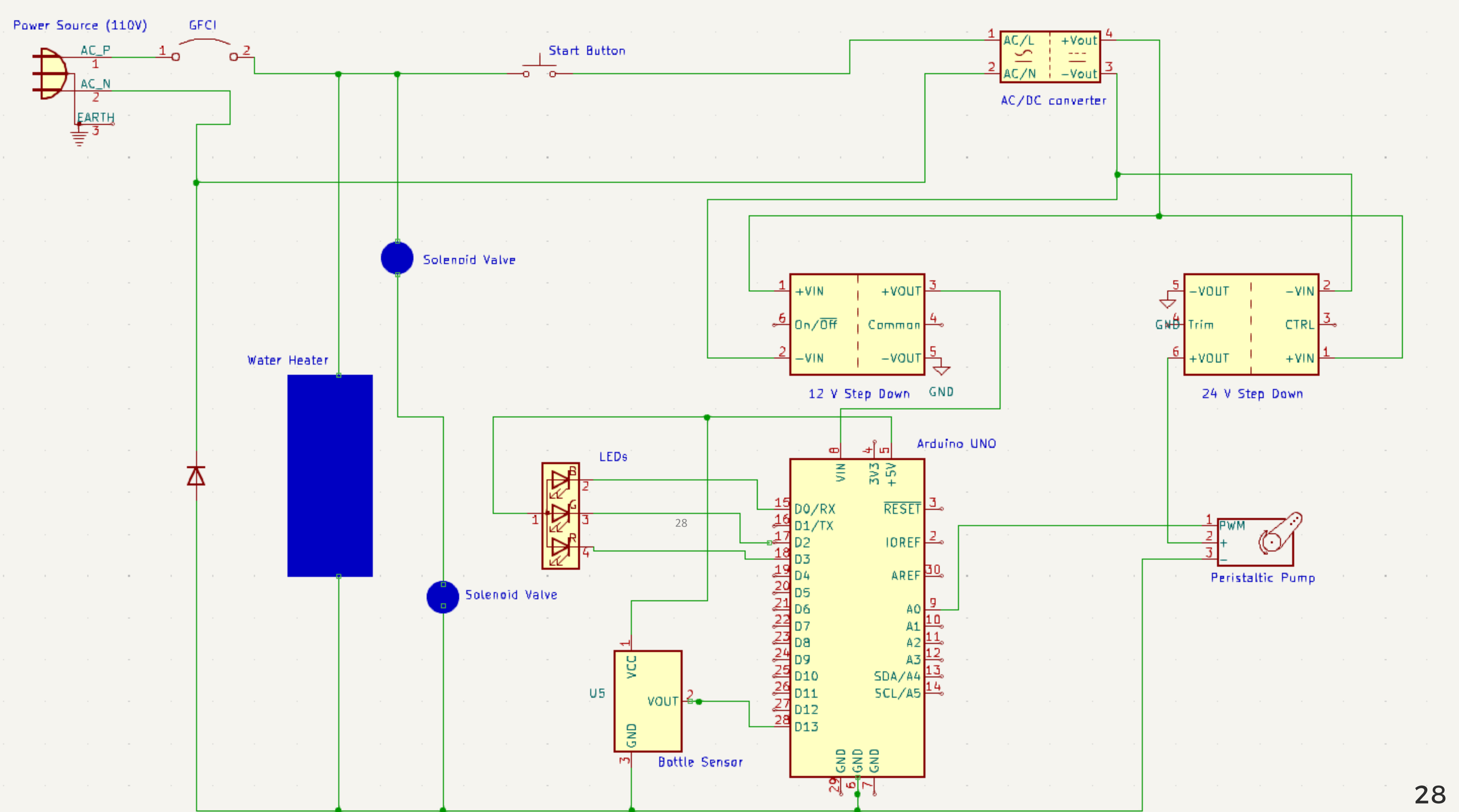

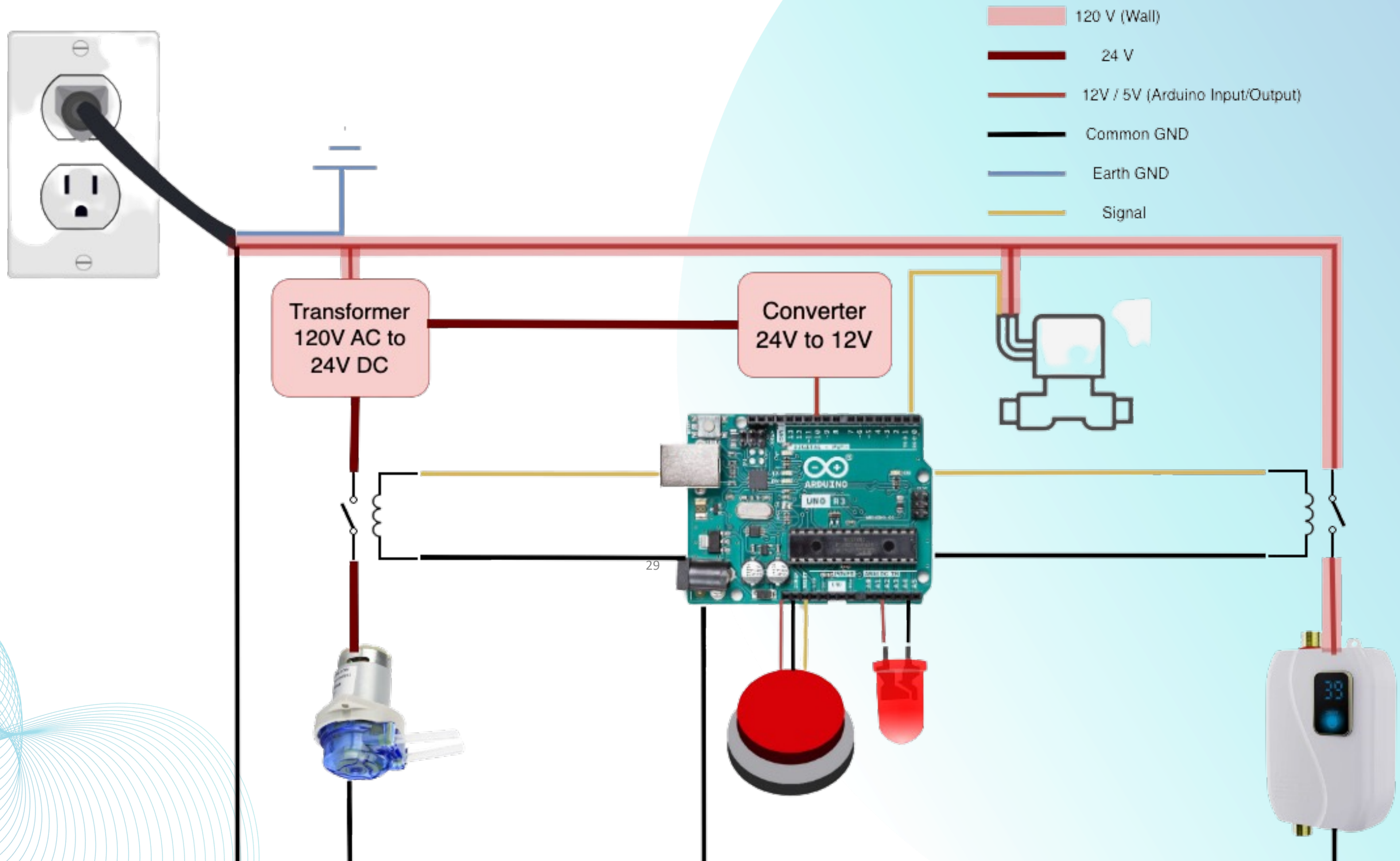

HOUSING

30

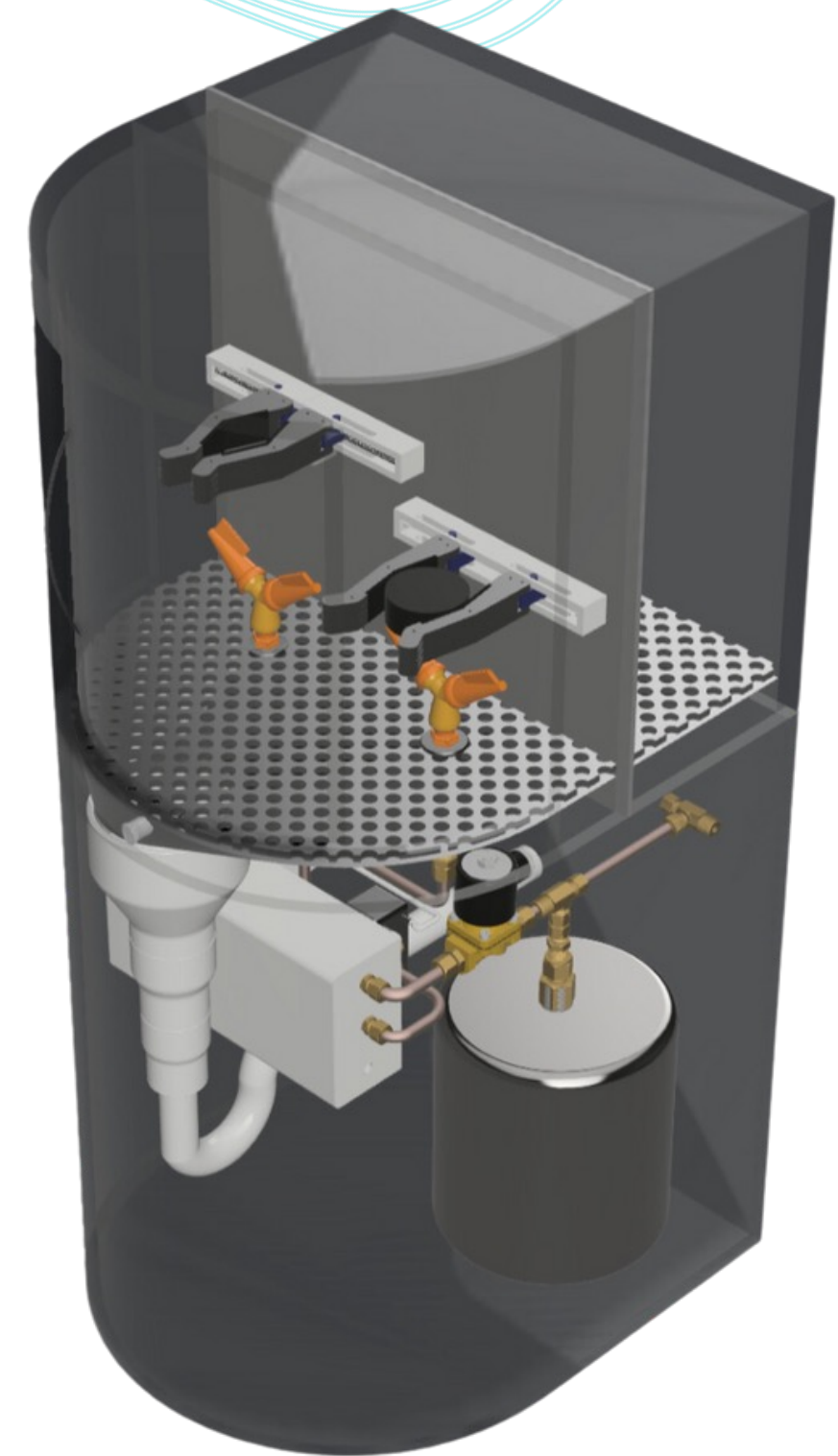

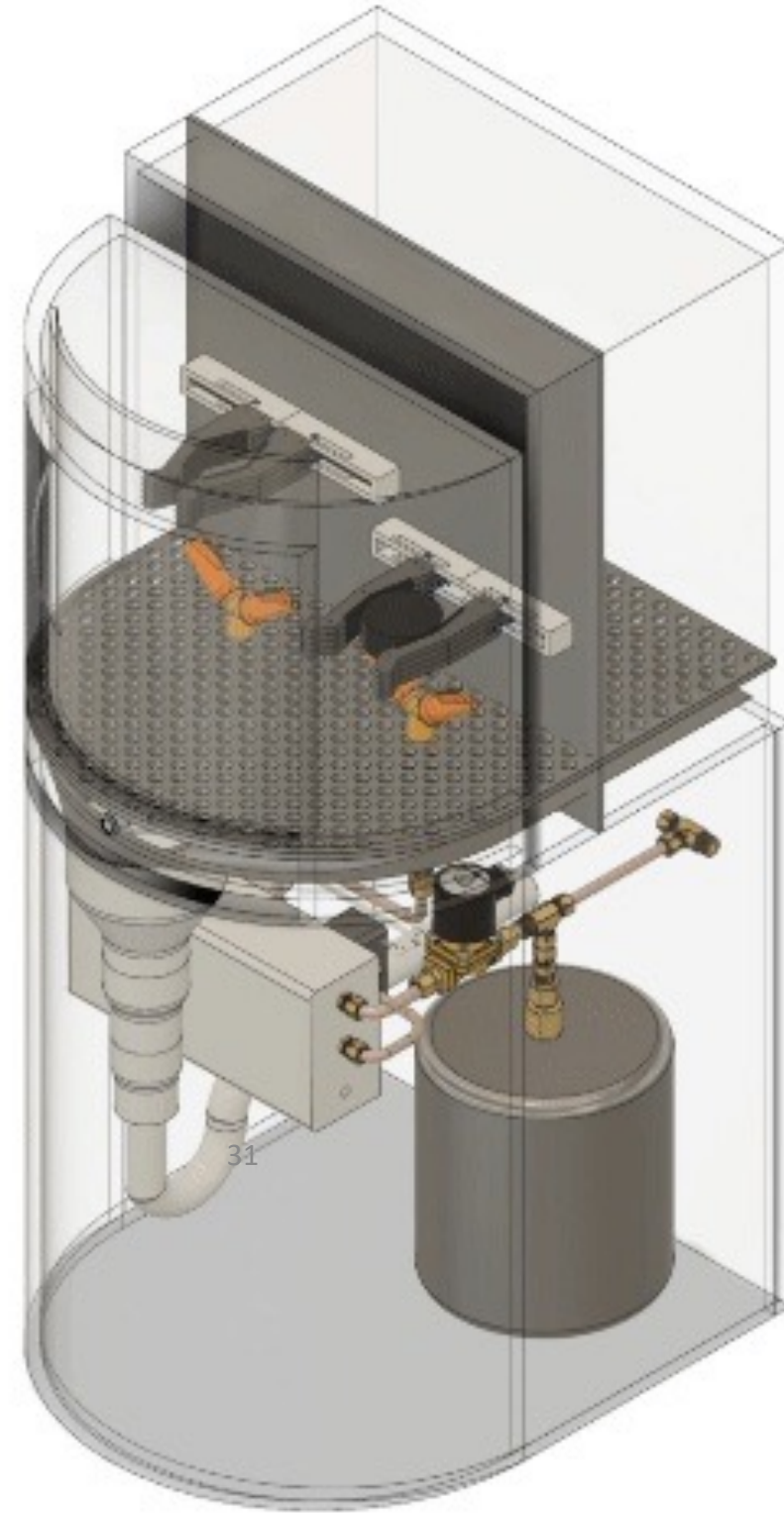

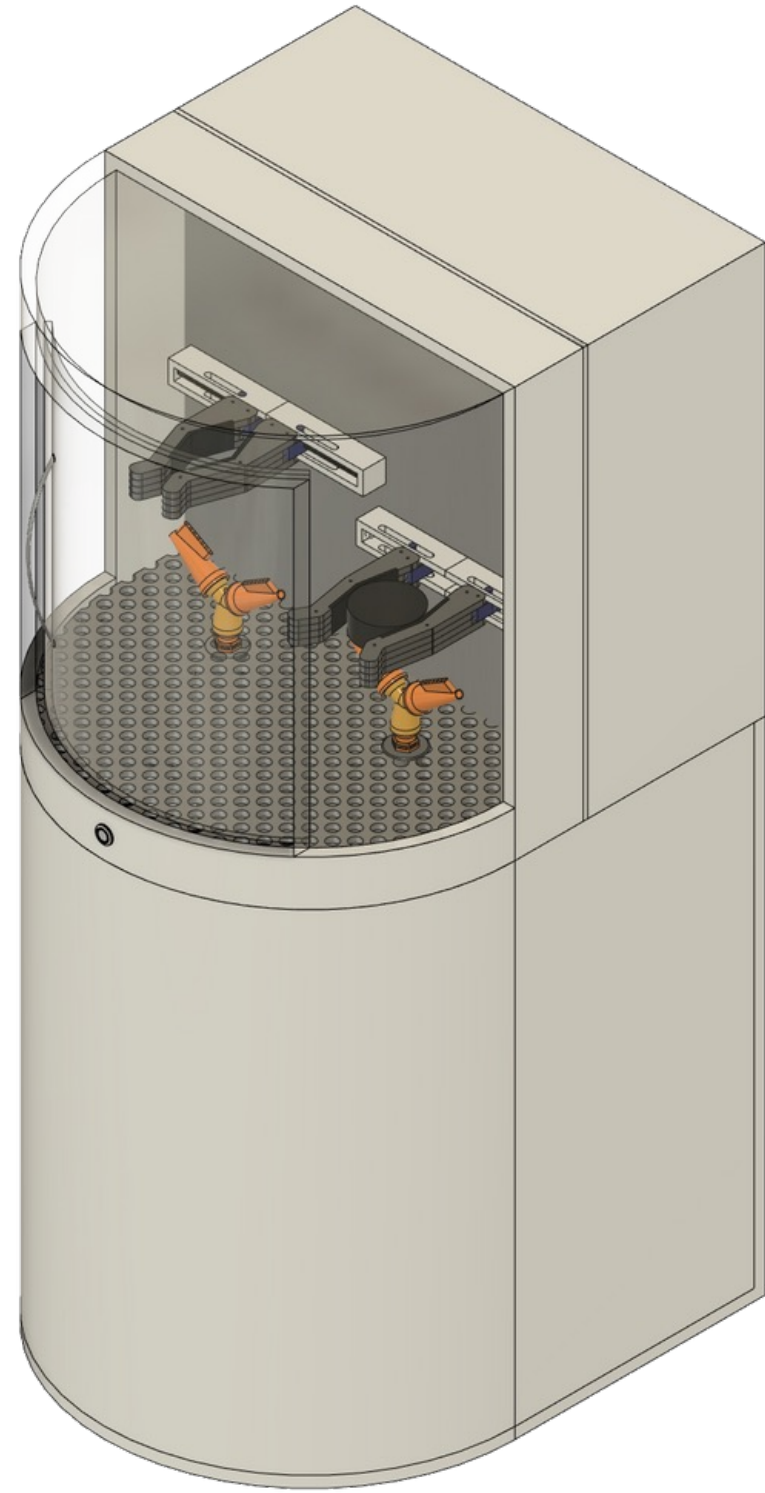

32

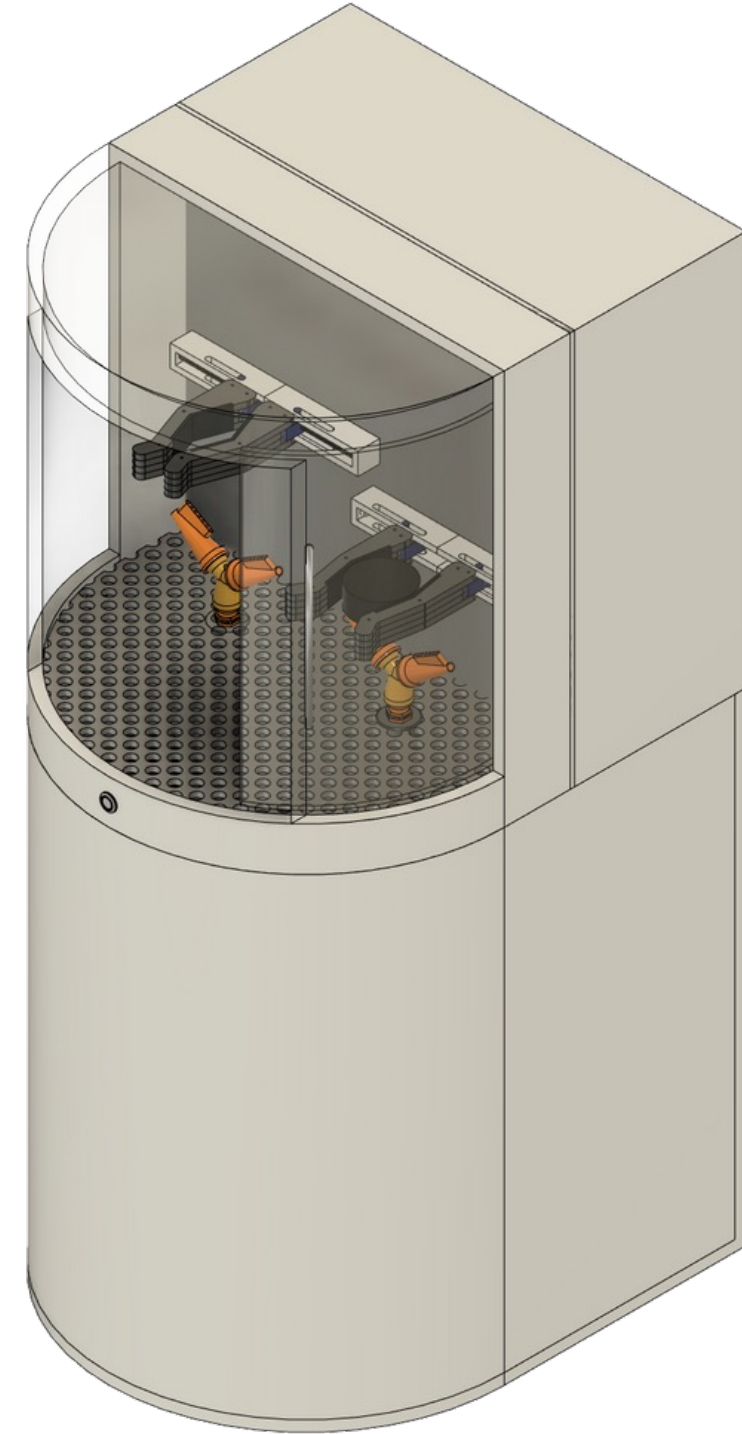

QUESTIONS?

33

APPENDIX

I. ELECTRONIC SCHEMATIC

35

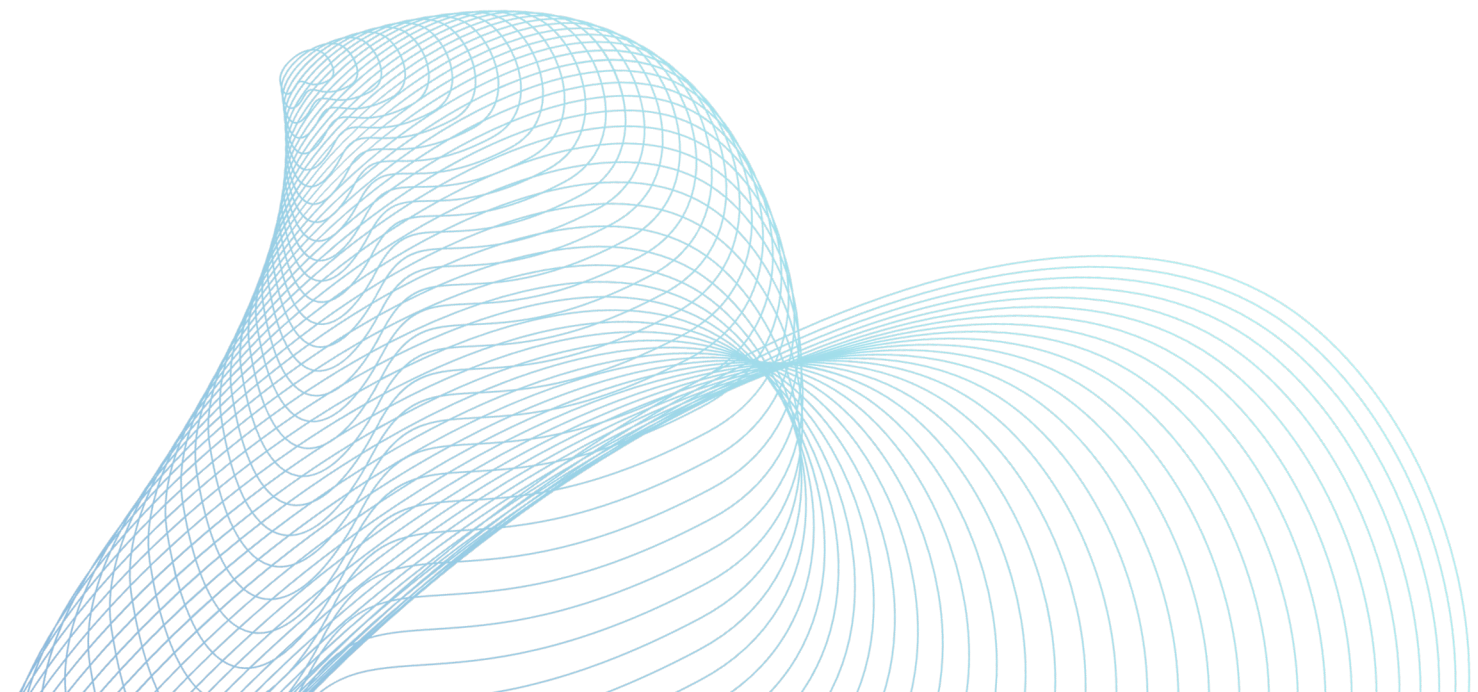

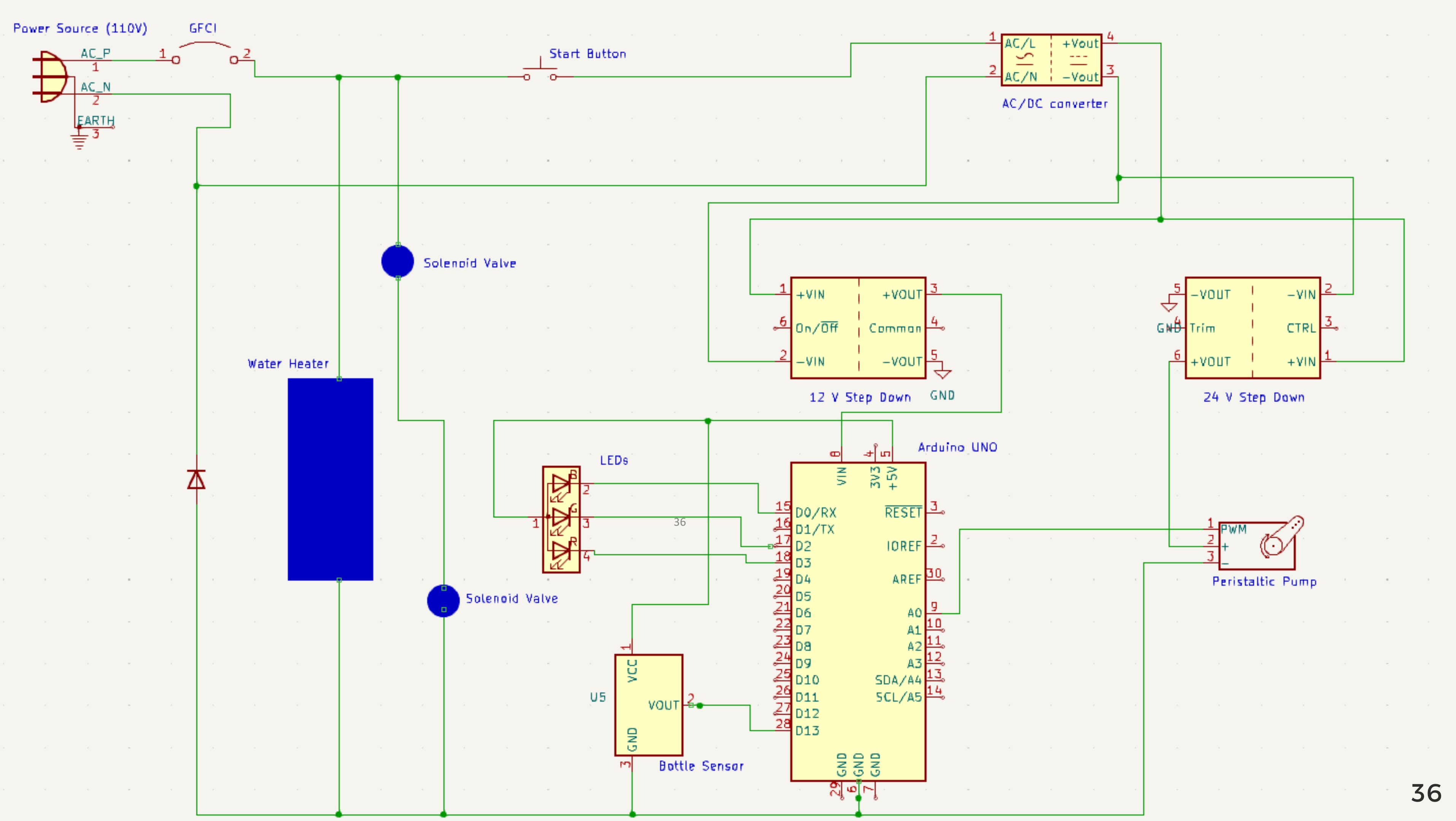

II. SPECIFICATIONS

37

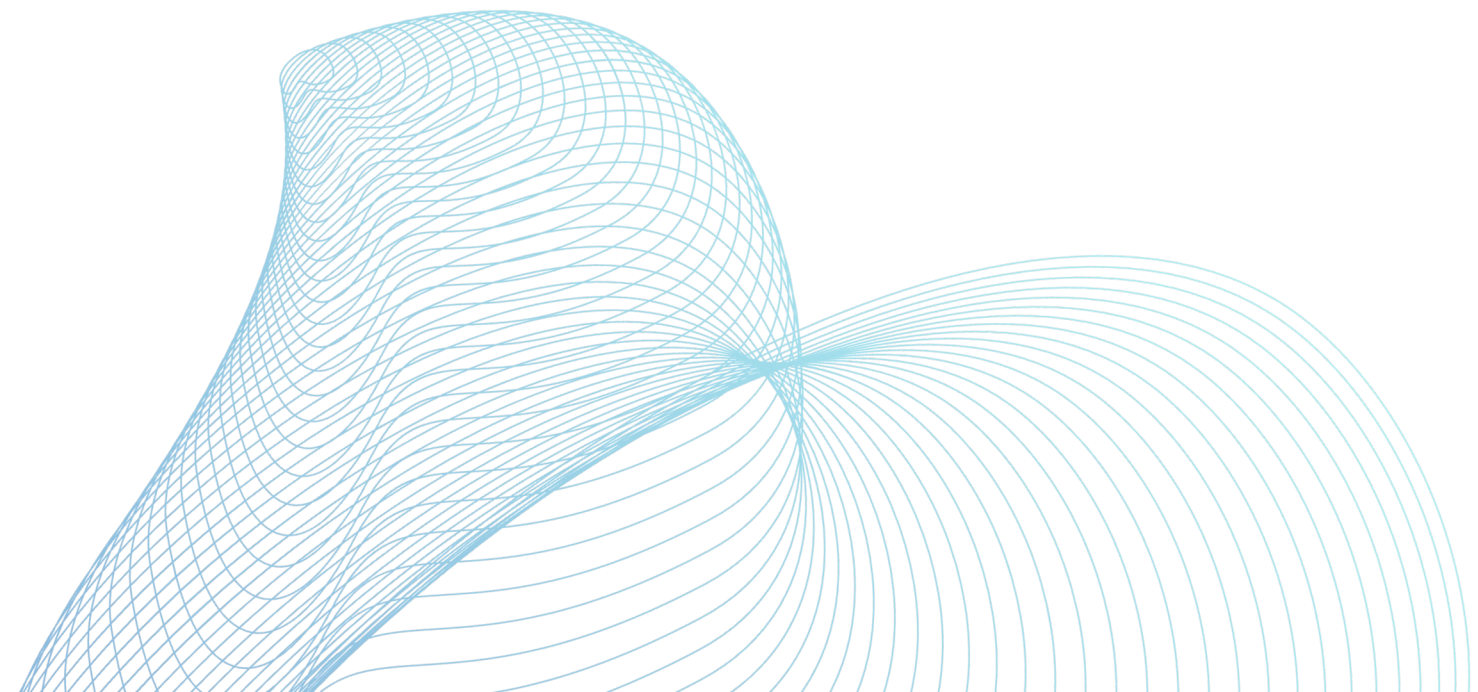

user need	product attribute	specification
water bottle free of germs	water temperature	NSF/ANSI 184 residential dishwasher standard of 150°F
cleans bottle quickly	time per cleaning cycle	less than 30 seconds
intuitive to set up and start	setup time per user	less than 10 seconds
can clean bottles and lids of a variety of shapes and sizes	<small>38</small> diameter and height of bottle and lid	bottle diameters: 1.9-3.5" bottle height: up to 11.5" lid diameters: 1-3.5"
water bottle safe to handle after cleaning	bottle temperature after cleaning	at or below 120°F

III. TESTING SET UPS

39

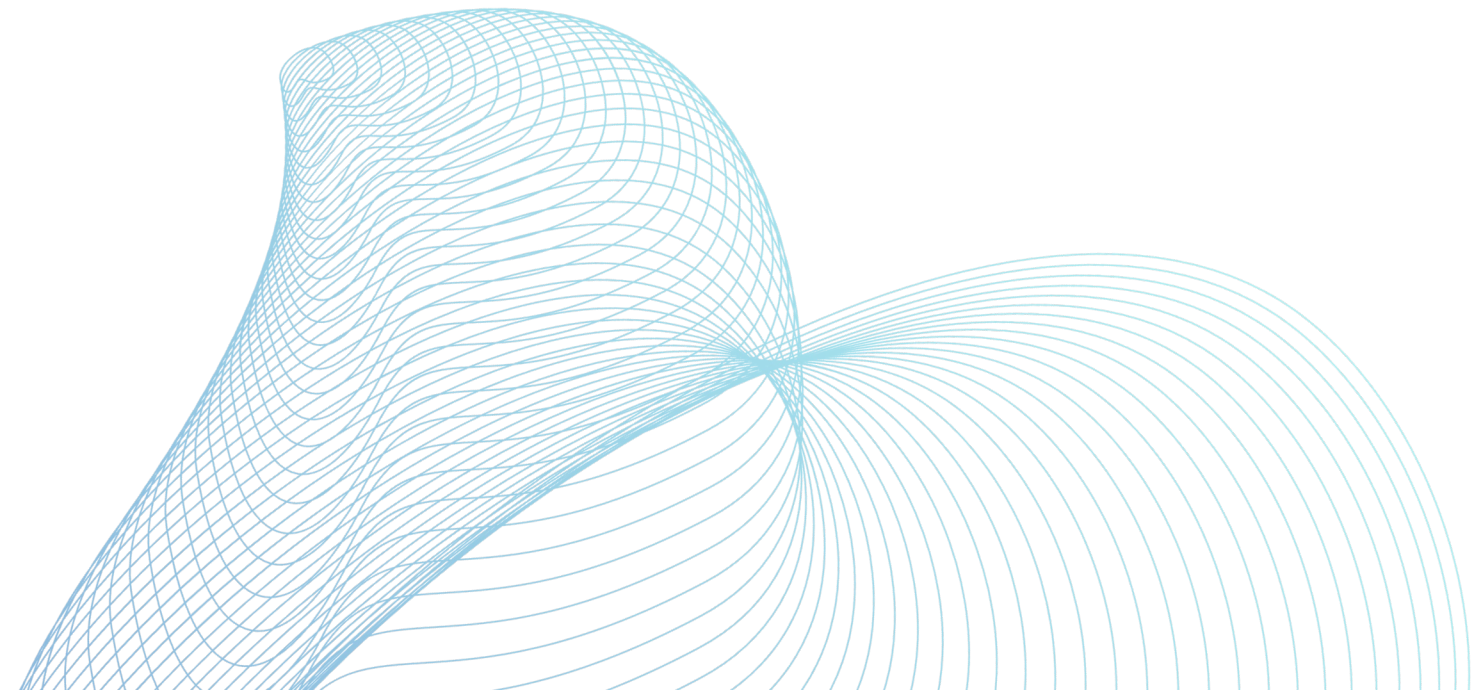

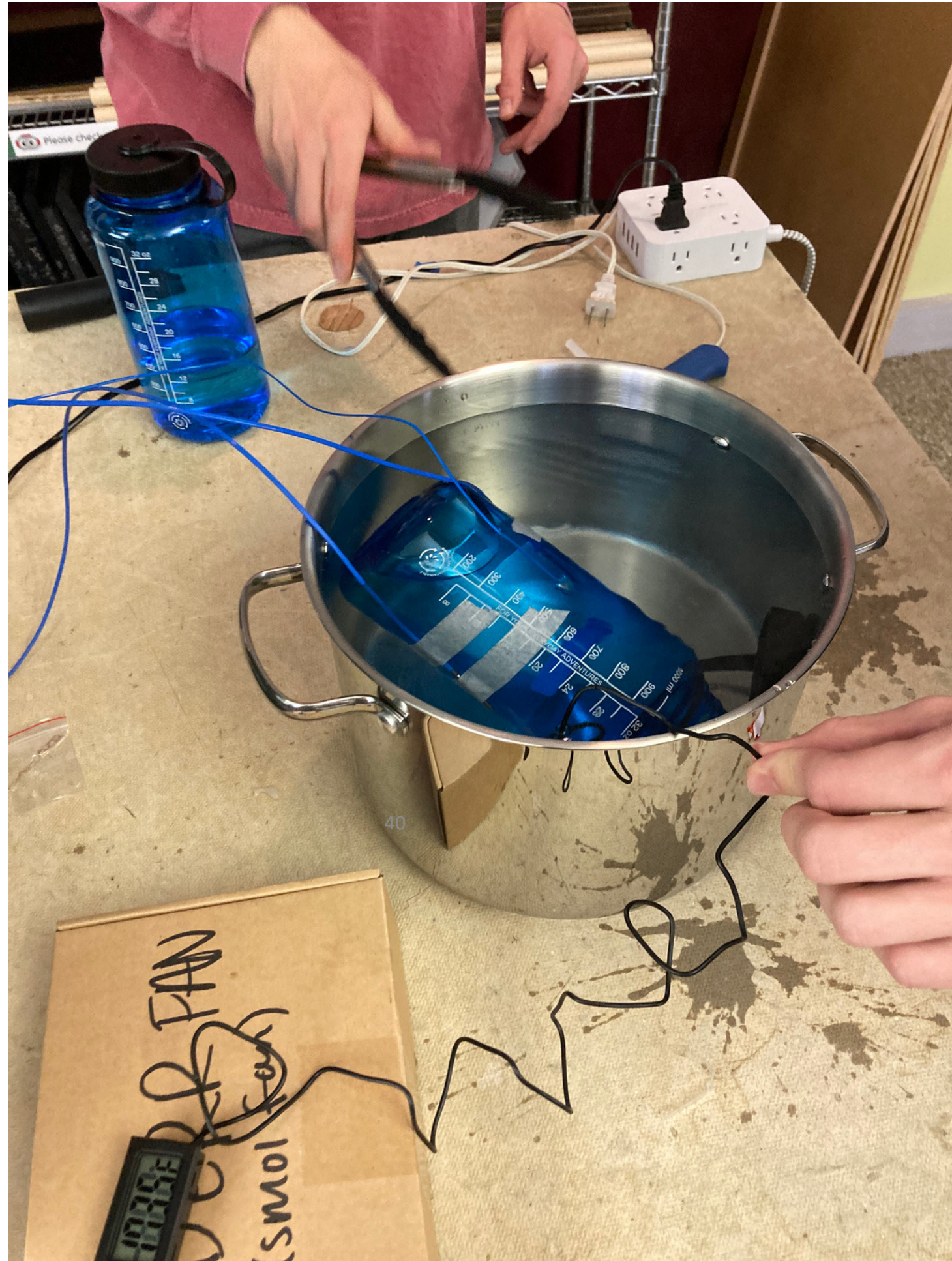

IV. INITIAL CALCULATIONS

41

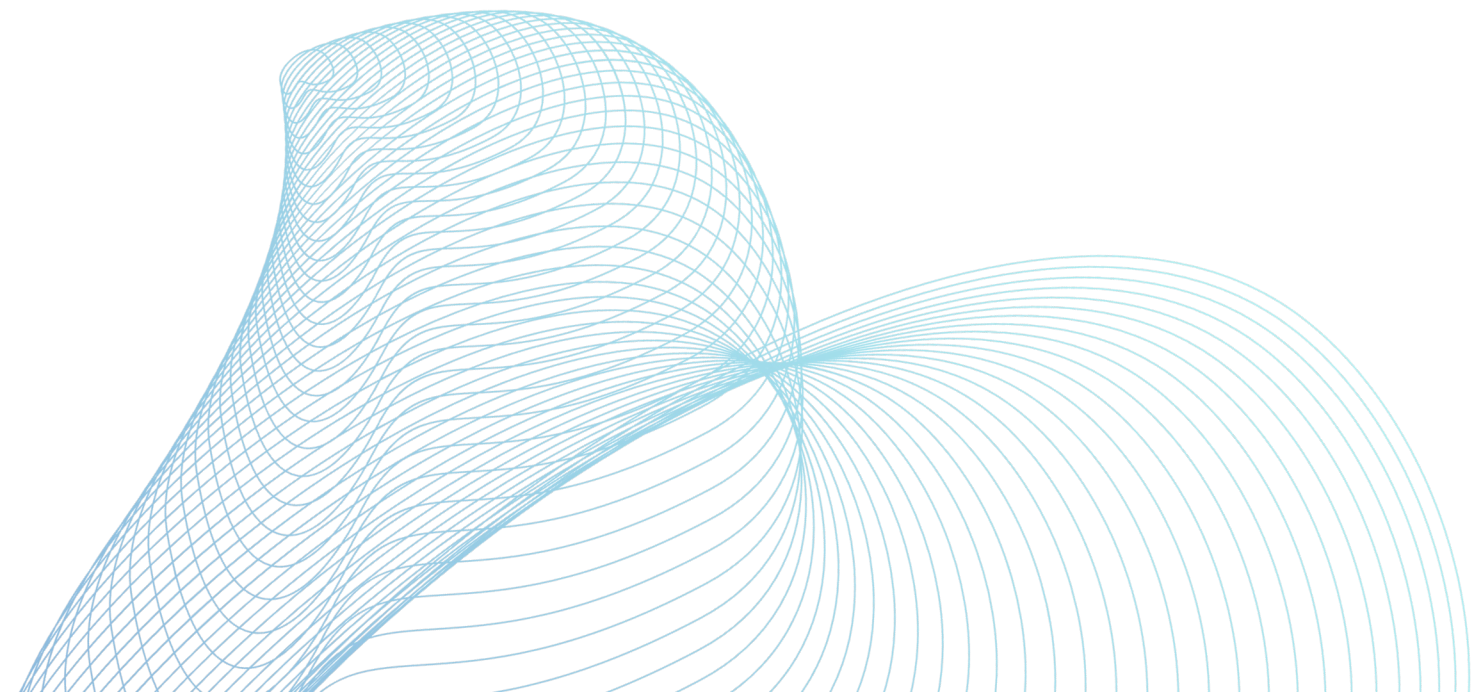

Clamping Force

Poron Coefficient of Friction: 0.40

Maximum Bottle Spring Load: 4.09 lbs

Maximum Lid Spring Load: 2.5 lbs

Max Bottle Weight:

$$\begin{aligned} & \textit{Poron coefficient of friction} * \textit{\# of springs} * \textit{spring max load} \\ & = 0.40 * 2 * 4.09 \textit{ lbs} = 3.272 \textit{ lbs} \end{aligned}$$

Max Lid Weight:

$$\begin{aligned} & \textit{Poron coefficient of friction} * \textit{\# of springs} * \textit{spring max load} \\ & = 0.40 * 2 * 2.5 \textit{ lbs} = 2 \textit{ lb} \end{aligned}$$