

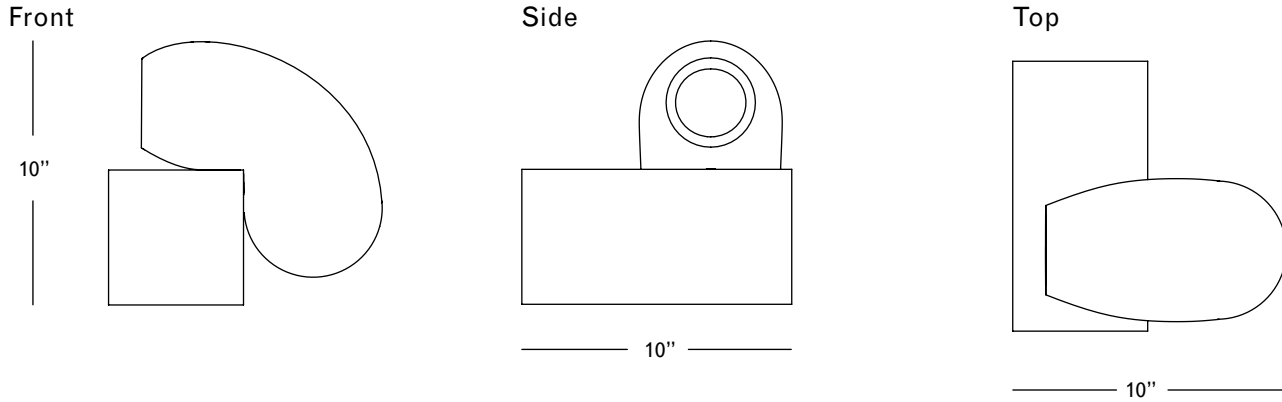

Brushed Brass  
White Glass



Finishes

Specifications

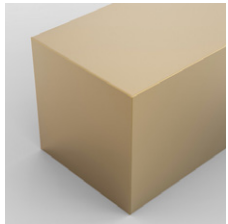

Brushed Brass  
\$9,500  
16 weeks

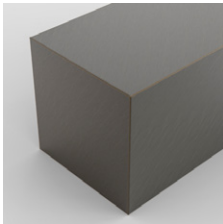

Oil Rubbed Bronze  
\$9,500  
24 weeks

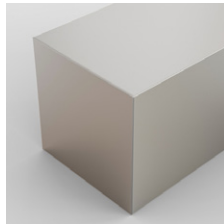

Satin Nickel  
\$9,500  
24 weeks

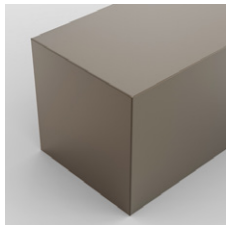

Vintage Brass  
\$9,500  
24 weeks

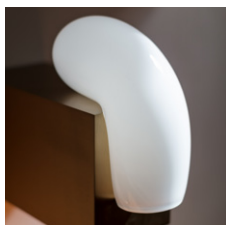

White

Height: 10in / 25cm  
Depth: 10in / 25cm  
Width: 10in / 25cm  
Weight: 15lb / 7kg  
Max Wattage: 2w

Mounting Hardware: French cleat and 5" x 5" x 10" brass box  
Materials: Machined brass, glass  
Bulbs: G4|12V|1.2W|2700K LED, dimmable, transformer provided



UL, cUL (120V) Certified

Inspiration

The Catch Box Sconce is a modular system of brass boxes and hand-blown glass. To create each piece, glass is blown directly onto the metal forms and left to slump with the weight of gravity as it cools. The resulting form exemplifies the organic nature of the material.