



Glycerin Infusion

INTERA 3000

HEPATIC ARTERY INFUSION PUMP

INSTRUCTION FOR USE

**Glycerin Injection
as a placebo for
Hepatic Arterial Floxuridine (FUdR)
chemotherapy interruption, when
used with the INTERA 3000
Hepatic Artery Infusion Pump**

Manufactured for:
Intera Oncology™, Inc.
65 William St., Suite 200
Wellesley, MA 02481 USA
☎ 800-660-2660
☎ 781-489-5724

Glycerin Infusion

INTERA 3000

Hepatic Artery Infusion Pump

INSTRUCTIONS FOR USE

1. INTRODUCTION:

Intera Oncology has established the following set of guidelines for the use of Glycerin Injection as a placebo for Hepatic Arterial Floxuridine (FUdR) chemotherapy interruption when used in the INTERA 3000 Hepatic Artery Infusion Pump. The Glycerin Injection may be used in the Pump to extend the period of Pump refill, and to keep the Pump catheter patent. The Pump is refilled percutaneously using a non-coring needle and tubing set as supplied in the refill kit.

2. GLYCERIN INJECTION PREPARATION*:

The Glycerin Injection is a sterile solution of Glycerin in Saline for Injection. Prepare a sterile solution of Glycerin Injection by diluting a suitable volume of Glycerin USP with 0.9% Saline for Injection. To sterilize the Injection by filtration, pass it through a sterile, chemically compatible membrane having a 0.2 µm or 0.22 µm nominal porosity. To sterilize the Injection by steam sterilization, pass the Injection through a 0.45 µm porosity filter into vials that are then sealed. Subject the sealed vials of Injection to a temperature of 121 degrees Celsius for a duration previously shown to sterilize a comparable number of containers of similar size.

*Adapted from Glycerin Injection USP Pharmacopeial Preview monograph.

3. INDICATIONS:

Glycerin infusion is indicated for patients who are receiving continuous Hepatic Arterial FUdR Chemotherapy. Glycerin infusion is employed as a placebo to keep the catheter patent or to extend the refill interval for patients who require therapy interruption or withdrawal:

Infusate

- Glycerin Injection

Indicated Route of Administration

- Arterial

4. CONTRAINDICATIONS:

Glycerin Injection is not intended for intraspinal delivery in INTERA 3000 Hepatic Artery Infusion Pumps with Bolus Safety Valve. Glycerin Infusion is not intended for use with any drugs or therapeutic agents other than FUdR.

5. WARNINGS:

The compounding of Glycerin Injection shall be in accordance with all applicable state and federal laws. Glycerin Injection should be compounded with Glycerin USP for high risk injections as defined in USP<1206>, including appropriate testing for sterility, bacterial endotoxins, and subvisible particulates. The compounded Glycerin Injection should comply with USP <1> Injections.

The Pump should be refilled only by qualified medical personnel, knowledgeable in the servicing of implantable devices and catheters, and trained specifically to refill the Pump. Use of the Pump by personnel not properly trained in its servicing may lead to serious consequences involving either under- or over-delivery of drug to the patient. In the event of an over-delivery of drug, refer to the approved drug labeling for appropriate action. Glycerin Injection is not intended for intraspinal delivery.

Utilization of the Pump requires the proper handling (filling, storage and dispensing) of a significant volume/dosage of drug. This amount of drug may be extremely harmful to the patient if delivered suddenly or inappropriately.

Bolus access and refill procedures must be performed using the correct access needle. Never attempt to refill the Pump using a Special Bolus Needle. This use will result in giving a bolus injection to the patient and may cause a fatal drug overdose.

6. PRECAUTIONS:

Hemolysis from Glycerin Infusion has been reported in the literature. The risk and degree of hemolysis from Glycerin Infusion when used as intended with implantable pumps are unknown. Testing for hemolysis should be considered.

7. DETERMINING DESIRED GLYCERIN INJECTION AND REFILL INTERVAL:

Please refer to Table 1 to assist you in determining the number of days between refills based on typically formulated Glycerin Injections, as well as, determining Glycerin Injection concentration for a given refill interval.

Since individual flow rates may vary, the refill intervals in Table 1 are estimates. Follow steps 7.1 to 7.3 to determine the actual refill interval. If the desired refill interval or concentration of Glycerin Injection is beyond the scope of Table 1, please refer to Appendix A (Alternate Method to Determine Appropriate Glycerin Injection Concentration) to better satisfy your needs.

7.1 Use the following formula to calculate the Glycerin Injection flow rate:

$$\text{(Current Flow Rate)}^a \times \text{(Conversion Factor)}^b = \text{(Glycerin Injection Flow Rate)}$$

SAMPLE CALCULATION:

$$1.2 \text{ mL/day}^c \times 0.26^d = 0.31 \text{ mL/day}$$

7.2 Use the following formula to calculate the actual refill interval:

$$\frac{\text{(Reservoir Volume)} \times 0.9^e}{\text{(Glycerin Flow Rate from 7.1)}} = \text{(Refill Interval with Glycerin Injection)}$$

SAMPLE CALCULATION:

$$\frac{30 \text{ mL} \times 0.9}{0.31 \text{ mL/day}} = 87 \text{ days}$$

7.3 Fill the Pump with the Glycerin Injection using the refill kit.

The next refill of the Pump should be scheduled according to your calculation from 7.2.

^a Nominal arterial flow rate of manufactured Pumps (at 100 mm Hg with 1000 u/mL Aqueous Heparin solution) is indicated on Pump labeling.

^b The Conversion Factor for the three typically formulated Glycerin Injections is listed in Reference Table 1. Specific Conversion Factors can be retrieved from Appendix A.

^c Example of an arterial flow rate of a High Flow 30 mL Pump. Please refer to the Pump labeling for arterial flow rate of manufactured Pump.

^d The Conversion Factor for a 50% Glycerin Injection.

^e This factor of 0.9 ensures that the Pump will not run dry before the expected refill date by accounting for 90% of the reservoir volume.
only

TABLE 1: GLYCERIN INJECTION REFERENCE TABLE

INTERA 3000 Series (Reservoir Volume)	*Labeled Flow Rate (Intra-arterial)	***Approximate Refill Interval
40% Glycerin Injection 0.38 **Conversion Factor	3000 (30 mL) High	54 to 60 Days
50% Glycerin Injection 0.26 **Conversion Factor	3000 (30 mL) High	79 to 87 Days
60% Glycerin Injection 0.17 **Conversion Factor	3000 (30 mL) High	122 to 133 Days

*Nominal arterial flow rate of manufactured Pumps (at 100 mm Hg with 1000 u/mL Aqueous Heparin solution). Individual flow rate may vary, and is indicated on Pump labeling.

**Please refer to the Glycerin Conversion Data Chart in Appendix A.

***Please refer to 7.1 and 7.2 for refill period calculation.

8. REFILLING THE PUMP WITH GLYCERIN INJECTION

To fill the INTERA 3000 Hepatic Artery Infusion Pump with Glycerin Injection, the following guidelines are recommended.

CAUTION: Use recommended personal protection for handling chemotherapeutic agents. Recommended reference: *Oncological Nurses Society for Chemotherapy Administration.*

CAUTION: Review Material Safety Data Sheets for Floxuridine (or any hazardous chemicals) to determine the required level of protection.

Using the Refill Kit (REF AP-07014US), prepare (2) syringes pre-filled with the appropriate Glycerin Injection.

REFILL VOLUME:

Model 3000 ----- 30 mL

- 8.1 Fill a 10 mL syringe with saline solution.
- 8.2 Using sterile technique, open Refill Kit and expose kit components.
- 8.3 Don sterile gloves. Use a disinfecting agent to prep the Pump site in a circular fashion extending the prepped area beyond the periphery of the Pump. Allow prepped area to dry. Place fenestrated drape over Pump site.
- 8.4 Attach the Needle and Stopcock to the Tubing Set. Stopcock and clamp are in the OPEN position. Next attach 50 mL calibrated syringe barrel to the Stopcock. Tighten all connections.

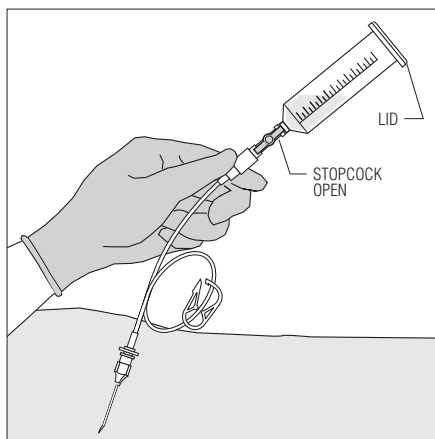

- 8.5 Re-palpate the Pump site and locate the raised septum.

8.6 Insert the Non-coring Needle PERPENDICULAR to the Pump septum. Advance the needle until it is in contact with the needle stop.

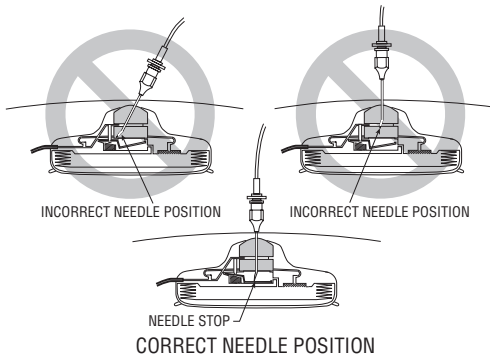

8.7 Allow Pump reservoir to empty. Keep downward pressure on the needle throughout the procedure. If no fluid returns, refer to Troubleshooting Guide for assistance.

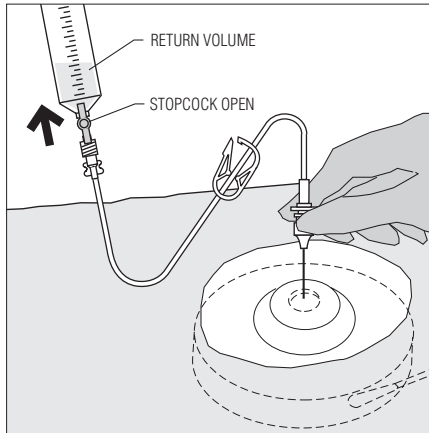

NOTE: After emptying, some fluid from the previous refill will remain in the Pump.

MODEL
3000

VOLUME:
approximately 1.5 mL

8.8 CLOSE STOPCOCK. Disconnect the stopcock and syringe barrel leaving the needle and refill set in place. Note the returned volume (mL), record on refill data sticker provided, and place in patient's permanent record. Discard syringe barrel and stopcock leaving the needle and refill set in place.

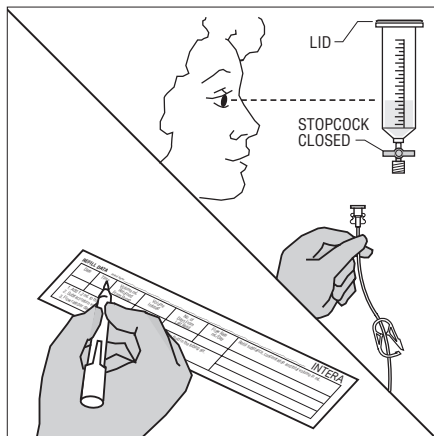

REFILL DATA Patient Name: _____							<input type="checkbox"/> INTERA 3000 (30 mL) <input type="checkbox"/> CODMAN 3000-16 (16 mL) <input type="checkbox"/> CODMAN 3000 (30 mL) <input type="checkbox"/> CODMAN 3000-50 (50 mL)
Date	Time	Volume mL Returned From Pump	¹ Volume Infused	No. of Days From Last Refill	² Flow Rate mL/Day	Refill substance, concentration and total volume in mL.	
1. Subtract return volume from volume at last refill: (30 mL for INTERA 3000, 16 mL for CODMAN [®] 3000-16; 30 mL for CODMAN 3000; 50 mL for CODMAN 3000-50). 2. Flow rate per day. Divide volume infused by number of days from last refill.							

EXAMPLE:

**INTERA 3000
30 mL Reservoir**

A	B	C	D
Volume Returned from Pump 2 mL	Volume Infused 30 mL – A 30 – 2 = 28 mL	No. of Days from Last Refill 28 days	Flow Rate B/C 28 mL/28 days = 1 mL/day

8.9 Expel air from the 10 mL syringe of saline. Attach the syringe to the proximal end of the refill set and confirm that the needle is still in contact with the needle stop. Keep downward pressure on the needle and inject 5 mL of saline into the Pump.

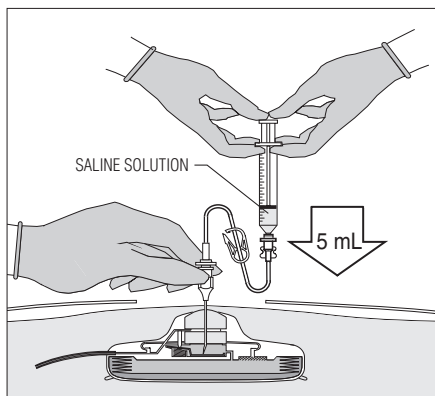

8.10 Release pressure on the plunger and allow the 5 mL of injected saline to return to the syringe. This procedure reconfirms correct positioning of the needle. If no fluid returns, refer to Troubleshooting Guide for assistance. Disconnect the syringe from the refill set.

8.11 Expel any air from one of the prefilled Glycerin Injection syringes. Thoroughly rinse the reservoir with the Glycerin Injection in order to minimize the dilution effect caused by the fluid still remaining in the drug reservoir. Attach appropriate volume syringe containing the Glycerin Injection to the proximal end of the refill set and confirm that the needle is still in contact with the needle stop.

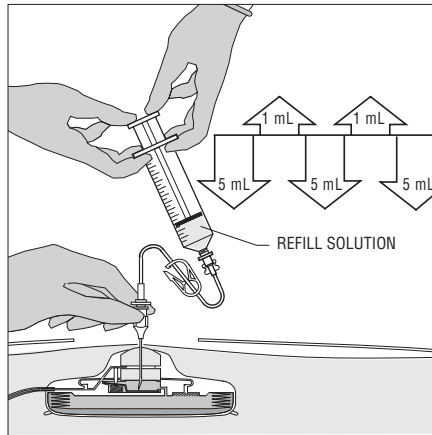

8.12 Keep downward pressure on the needle and begin to inject refill solution into the Pump. Release pressure on plunger at 5 mL increments and allow 1 mL of solution to return to syringe. This will verify that the needle is in the correct position and the Pump reservoir is being filled. Continue to inject and check needle placement until the syringe is emptied.

PRECAUTION: If no fluid returns to the syringe upon release of the plunger, DO NOT CONTINUE TO INJECT REFILL SOLUTION UNTIL YOU HAVE VERIFIED THE NEEDLE PLACEMENT PER THE PROCEDURE IN THE TROUBLE-SHOOTING GUIDE. Follow steps A, B, C, D per the Troubleshooting Guide.

8.13 Allow the entire volume of Glycerin Injection to return to the syringe.

8.14 After the reservoir rinse is complete expel any air from the second prefilled Glycerin Injection syringe. Attach appropriate volume syringe containing the Glycerin Injection to the proximal end of the refill set and confirm that the needle is still in contact with the needle stop. Inject refill solution as in 8.12.

8.15 After injecting the appropriate volume of Glycerin Injection, close the clamp on the tubing set and pull the needle out of the Pump septum. Remove drape and apply an adhesive bandage to access site.

Special Note: Inform patient of date, time and place for next pump refill.

9. RESUMING DRUG THERAPY:

To re-start drug infusion via the INTERA 3000 Series Pump, the following guidelines are recommended.

Using the **INTERA 3000 Series Refill Kit** (REF AP-07014US), prepare (2) syringes pre-filled with sterile saline. Refer to Pump model number for appropriate volume.

REFILL VOLUME:

Model 3000 ----- 30 mL

- 9.1** Fill a syringe with appropriate refill solution (refer to model for proper volume) and a 10 mL syringe with saline solution.
- 9.2** Using sterile technique, open Refill Kit and expose kit components.
- 9.3** Don sterile gloves. Use a disinfecting agent to prep the Pump site in a circular fashion extending the prepped area beyond the periphery of the Pump. Allow prepped area to dry. Place fenestrated drape over Pump site.
- 9.4** Attach the Needle and Stopcock to the Tubing Set. Stopcock and clamp are in the OPEN position. Next attach 50 mL calibrated syringe barrel to the Stopcock. Tighten all connections.

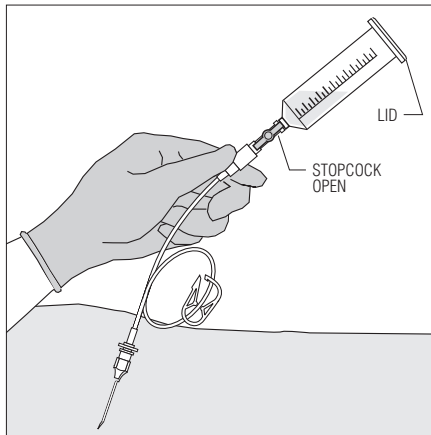

- 9.5** Re-palpate the Pump site and locate the raised septum.

9.6 Insert the Non-coring Needle PERPENDICULAR to the Pump septum. Advance the needle until it is in contact with the needle stop.

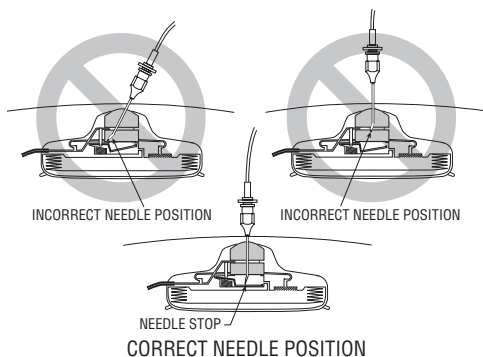

9.7 Allow Pump reservoir to empty. Keep downward pressure on the needle throughout the procedure. If no fluid returns, refer to Troubleshooting Guide for assistance.

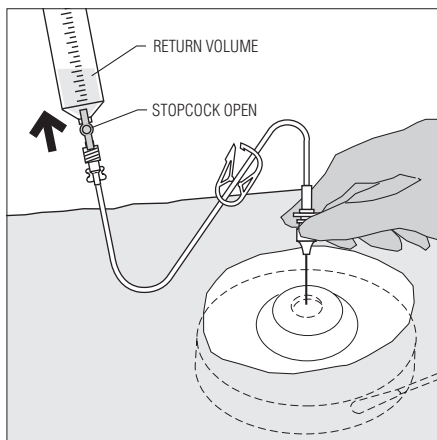

NOTE: After emptying, some fluid from the previous refill will remain in the Pump.

<u>MODEL</u>	<u>VOLUME:</u>
3000	approximately 1.5 mL

9.8 CLOSE STOPCOCK. Disconnect the stopcock and syringe barrel leaving the needle and refill set in place. Note the returned volume (mL), record on refill data sticker provided, and place in patient's permanent record. Discard syringe barrel and stopcock leaving the needle and refill set in place.

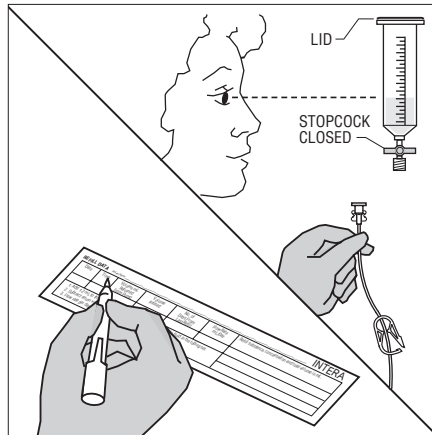

Date		Time	Volume mL Returned From Pump	¹ Volume Infused	No. of Days From Last Refill	² Flow Rate mL/Day	Refill substance, concentration and total volume in mL.
<p>1. Subtract return volume from volume at last refill: (30 mL for INTERA 3000, 16 mL for CODMAN[®] 3000-16; 30 mL for CODMAN 3000; 50 mL for CODMAN 3000-50).</p> <p>2. Flow rate per day. Divide volume infused by number of days from last refill.</p>							

INTERA 3000 (30 mL)
 CODMAN 3000-16 (16 mL)
 CODMAN 3000 (30 mL)
 CODMAN 3000-50 (50 mL)

EXAMPLE:	A	B	C	D
INTERA 3000 30 mL Reservoir	Volume Returned from Pump 2 mL	Volume Infused 30 mL – A 30 – 2 = 28 mL	No. of Days from Last Refill 28 days	Flow Rate B/C 28 mL/28 days = 1 mL/day

- 9.9** Expel air from the 10 mL syringe of saline. Attach the syringe to the proximal end of the refill set and confirm that the needle is still in contact with the needle stop. Keep downward pressure on the needle and inject 5 mL of saline into the Pump.

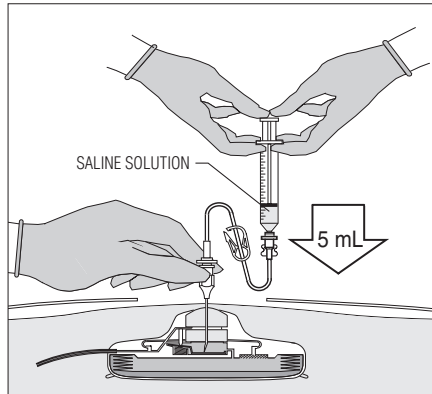

- 9.10** Release pressure on the plunger and allow the 5 mL of injected saline to return to the syringe. This procedure reconfirms correct positioning of the needle. If no fluid returns, refer to Troubleshooting Guide for assistance. Disconnect the syringe from the refill set.
- 9.11** Expel any air from the saline syringes. Thoroughly rinse the reservoir twice with sterile saline to dilute the concentration of Glycerin Injection still remaining in the drug reservoir. Attach appropriate volume saline syringe to the proximal end of the refill set and confirm that the needle is still in contact with the needle stop.

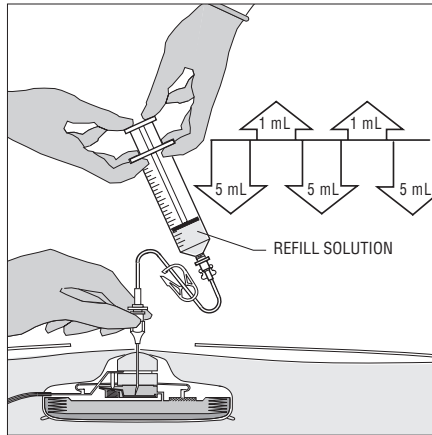

9.12 Keep downward pressure on the needle and begin to inject solution into the Pump. Release pressure on plunger at 5 mL increments and allow 1 mL of solution to return to syringe. This will verify that the needle is in the correct position and the Pump reservoir is being filled. Continue to inject and check needle placement until the syringe is emptied.

PRECAUTION: If no fluid returns to the syringe upon release of the plunger, DO NOT CONTINUE TO INJECT REFILL SOLUTION UNTIL YOU HAVE VERIFIED THE NEEDLE PLACEMENT PER THE PROCEDURE IN THE TROUBLE-SHOOTING GUIDE. Follow steps A, B, C, D per the Troubleshooting Guide.

9.13 Allow the entire volume of saline to return to the syringe. Attach second appropriate volume saline syringe to the proximal end of the refill set and confirm that the needle is still in contact with the needle stop. Repeat 9.12 and again allow the entire volume of saline to return to the syringe.

9.14 After the reservoir rinse is complete, expel any air from the syringe filled with the appropriate refill solution. Attach appropriate volume syringe containing the refill solution to the proximal end of the refill set and confirm that the needle is still in contact with the needle stop. Inject refill solution as in 9.12.

9.15 After injecting the appropriate volume of drug, close the clamp on the tubing set and pull the needle out of the Pump septum.

Special Note: Inform patient of date, time and place for next pump refill.

9.16 After the reservoir has been rinsed and refilled with the intended drug solution it is important to flush the bolus pathway to remove the Glycerin solution from the bolus channel and silicone catheter.

9.17 BOLUS PATHWAY FLUSH:

WARNING: NEVER attempt to REFILL the Pump using an INTERA SPECIAL BOLUS NEEDLE. This use will result in giving a bolus injection to the patient and may cause a fatal drug overdose.

PRECAUTION: 1) Before performing a bolus injection of any drug, review all warnings, precautions, indications and contraindications on the drug labeling.

PRECAUTION: 2) Use only an INTERA SPECIAL BOLUS NEEDLE for performing a bolus procedure.

PRECAUTION: 3) Do not aspirate fluid/blood back through the bolus path as a catheter occlusion may result.

PRECAUTION: 4) Do not use a mechanical pressure injector system to accomplish a bolus procedure. Pressures should not exceed 40 psi when administering a bolus injection or infusion. For injections use only 10 mL (or larger) syringes and do not inject or infuse at a rate greater than 5 mL/minute.

9.17.1 Fill a 10 mL syringe with a saline solution. Connect the syringe to the SPECIAL BOLUS NEEDLE (REF AP-04013 or AP-04032).

9.17.2 Open the clamp and inject 3 mL of solution to flush the tubing set and needle of air. Close the clamp.

9.17.3 Insert the needle into the septum until contact is made with the needle stop. Ensure that the needle is PERPENDICULAR to the Pump and that the contact with the needle stop is maintained throughout the procedure. NOTE: If the needle does not remain fully inserted and in contact with the needle stop, the bolus valve will close and it will not be possible to accomplish the bolus procedure. Open the clamp and flush the system with 3 mL of saline. Close the clamp, remove the syringe and SPECIAL BOLUS NEEDLE from the Pump septum. Remove drape and apply an adhesive bandage.

PRECAUTION: When the system is flushed with saline, the patient will receive a bolus dose of drug equal to the volume of drug contained in the internal bolus pathway of the Pump (refer to *Bolus Table), plus the volume of the drug in the catheter. The volume of the drug in the internal pathway of the Pump and the volume of the drug contained in the catheter, can be calculated by multiplying the length (in cm) of the catheter utilized by the volume of fluid contained per cm of catheter. Please refer to the table below.

*BOLUS TABLE

Volume of Drug in the internal –					
<u>Bolus Pathway of the Pump</u>		<u>Volume of Drug in Catheter</u>		<u>Total Volume</u>	
3000	0.3 mL	+	0.003 mL/cm x 50 = 0.15	➔	0.45 mL

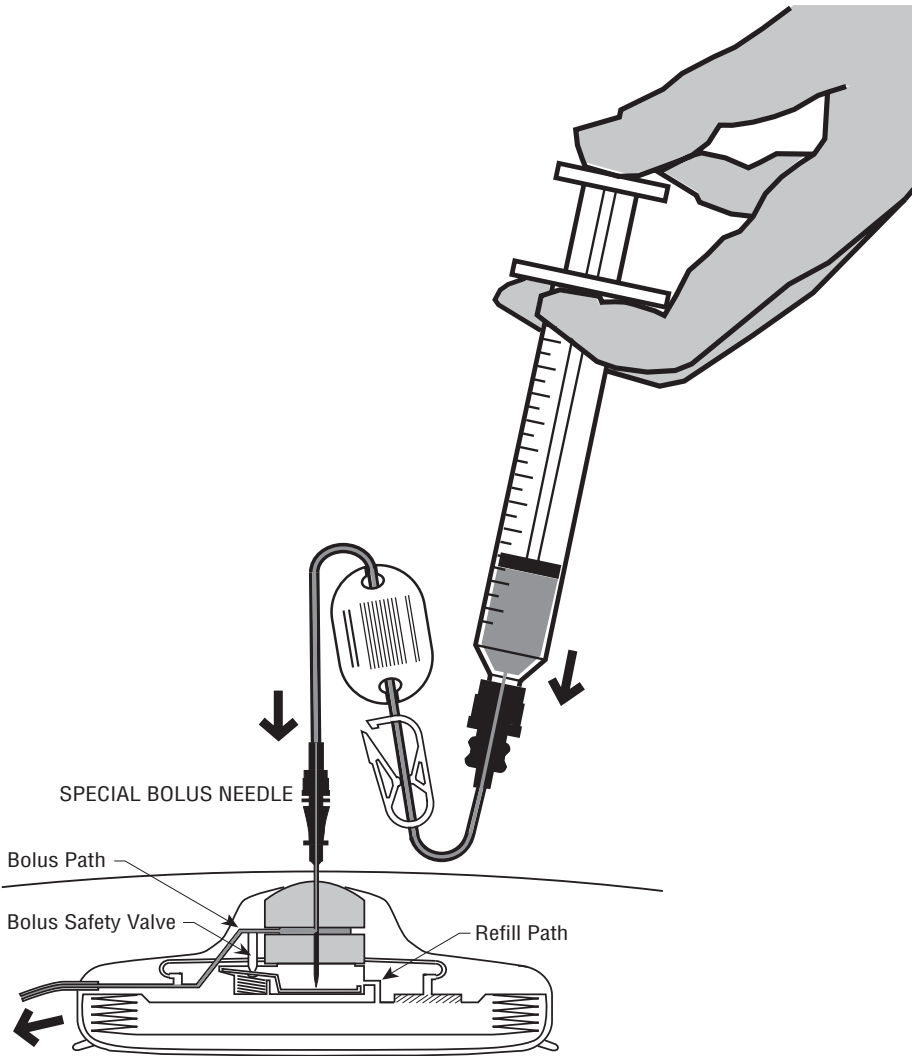

Flushing the Bolus Pathway

10. TROUBLESHOOTING GUIDE:

If no fluid returns during Pump emptying, or during the Refill Injection Procedure, proceed as follows;

A. Confirm needle position and that a 22 gauge, Non-coring Needle is being used. Check that the needle is PERPENDICULAR to the pump septum and is fully depressed and in contact with the needle stop. If no volume returns proceed with steps B, C, D.

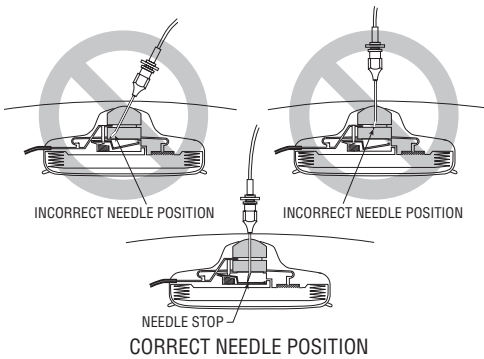

B. Attach a 10 mL syringe containing saline solution to the refill tubing set.

C. Keep downward pressure on the needle and inject 5 mL of saline into the Pump. Release pressure on the syringe plunger and allow the fluid to return to the syringe. If fluid returns then the needle is in the proper position and indicates that the Pump was empty at the start of the refill procedure. Replace the 10 mL syringe with the syringe containing the Pump refill solution and continue with the refill procedure (steps 12 and 13).

D. If there is still no fluid return after injection of the 5 mL of saline, remove needle and refill tubing set. Flush the refill set to confirm that the system is patent. Re-insert the needle perpendicular into the Pump septum until it is in contact with the needle stop. Repeat step C.

E. If there is still no fluid return after injection of the 5 mL of saline, contact Intera Oncology, Inc. for 24-Hour Technical Assistance at 800-660-2660.

APPENDIX A

ALTERNATE METHOD TO DETERMINE APPROPRIATE GLYCERIN INJECTION CONCENTRATION

Please follow these three steps to determine the appropriate concentration of Glycerin Injection which will achieve a desired refill interval.

STEP 1.

1a. Calculate the *CURRENT* number of days between refill procedures with the following formula:

$$\frac{\text{Reservoir volume} \times 0.9}{\text{Current Flow Rate}} = \text{Current number of days between refills}$$

1b. SAMPLE CALCULATION:

$$\frac{30 \text{ ml} \times 0.9}{1.2 \text{ mL/day}} = 22.5 \text{ days}$$

1c. Please perform this calculation using the actual flow rate and reservoir volume of your patient's Pump. Record the value below.

_____ (Current days between refills)

STEP 2.

2a. Decide on the number of days between refills that you would like to achieve for this Pump.

_____ (Desired number of days between refills)

2b. Using the "Current number of days between refills" that you calculated (Step 1c) and using the "Desired number of days between refills" (Step 2a) please use the following formula to calculate a "Conversion Factor".

$$\frac{\text{Current number of days between refills}}{\text{Desired number of days between refills}} = \text{Conversion Factor}$$

2c. SAMPLE CALCULATION:

$$\frac{22.5 \text{ days}}{87 \text{ days}} = 0.26 \text{ Conversion Factor}$$

2d. Please perform this calculation and record the value below.

_____ (Conversion Factor)

STEP 3.

3a. Locate the "Conversion Factor" (from Step 2d) on the graph shown. Follow the graph to the right until you reach the curved line. Move downward from the curved line to find the concentration of Glycerin Injection that you must fill the Pump with in order to achieve your desired number of days between refills

3b. Sample: The calculated conversion factor of 0.26 intersects the curved line at 50% Glycerin Injection. 50% Glycerin Injection will achieve a period of 87 days between refills.

3c. Please determine and record the necessary concentration of Glycerin Injection from the graph:

_____ % Glycerin Injection

3d. Fill the Pump with a Glycerin Injection of this concentration using the Refill Kit. The next refill of the Pump should be scheduled according to Step 2a. Refer to Section 8 of this booklet for filling instructions.

INTERA 3000 Pump Glycerin Conversion Factor

(Compared to 1000 u/mL Heparin solutions)

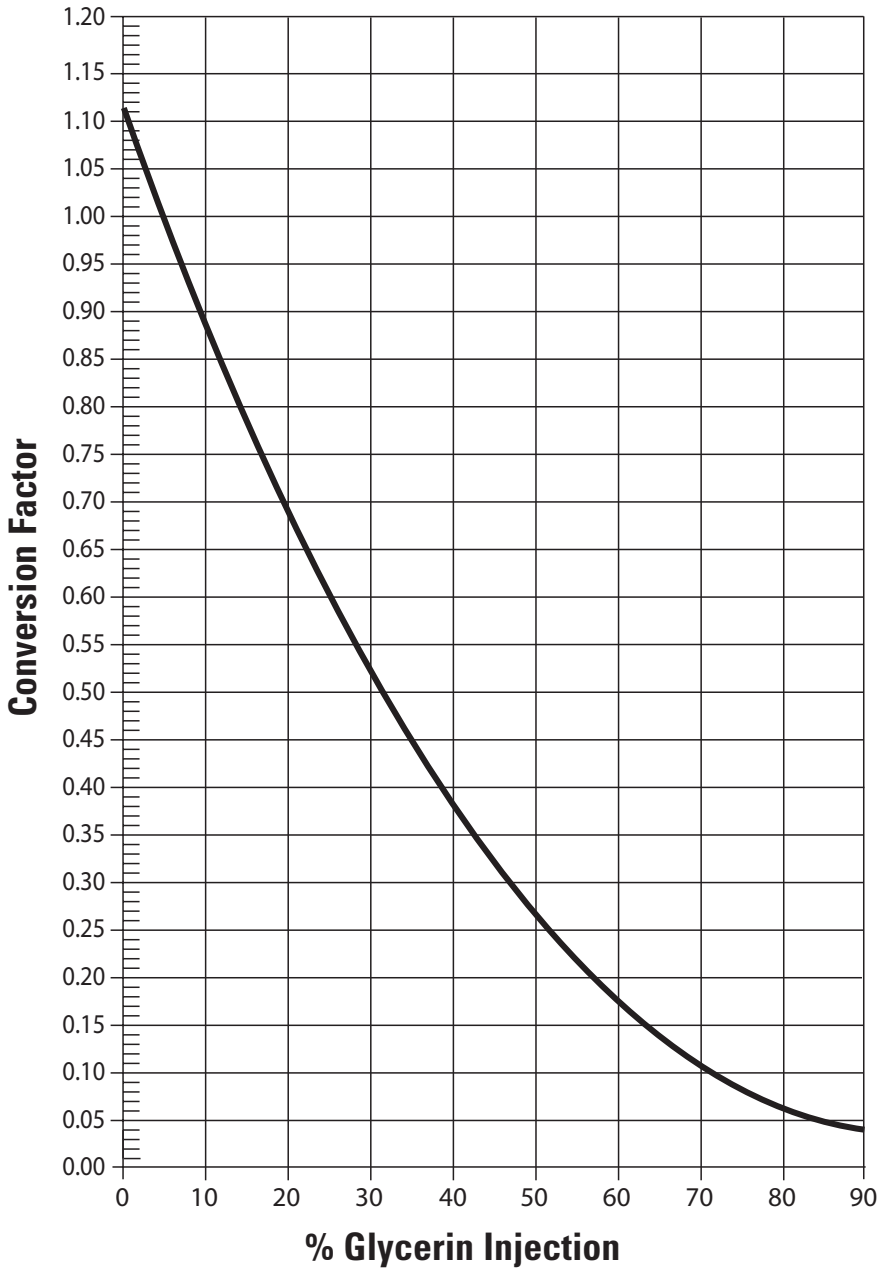

SYMBOLS GLOSSARY



Do not resterilize



Do not use if package is damaged



Prescription device only (USA)



Distributed by



Made in



Nonpyrogenic, see Instructions for Use



Quantity

Manufactured for:
Intera Oncology, Inc.
65 William St., Suite 200
Wellesley, MA 02481 USA
☎ 800-660-2660
☎ 781-489-5724

TLB-3496-X Rev. A
© 2019 Intera Oncology, Inc.
All Rights Reserved.
♻ Revised 07/2020