

**Technical Visit to New Zealand (2 to 9 March 2019)**  
**Study of Innovative Construction Technologies Applied**  
**to Infrastructure Projects in New Zealand**

**Final Report**

Hong Kong Institution of Engineers  
(Geotechnical Division)



---

**Geotechnical Division**  
岩土分部

# Contents

<b>1. INTRODUCTION</b> .....	4
<b>2. OBJECTIVES OF TECHNICAL VISIT</b> .....	4
<b>3. ITINERARY AND DETAILS OF ACTIVITIES</b> .....	4
<b>3.1. Auckland</b> .....	5
<b>3.2. Kaikoura</b> .....	6
<b>3.3. Christchurch</b> .....	7
<b>4. KEY LEARNINGS AND TAKE-AWAYS</b> .....	9
<b>4.1. Adaptation in handling engineering challenges</b> .....	9
<b>4.2. Development and application of digital technologies</b> .....	11
<b>4.3. Construction, innovation and preservation</b> .....	14
<b>4.4. Advancement in geotechnical research for earthquakes</b> .....	18
<b>5. CONCLUSIONS</b> .....	21
<b>REFERENCES</b> .....	21

## List of Figures

<b>Figure no.</b>	<b>Title</b>	<b>Page no.</b>
<b>1</b>	Places visited in New Zealand	4
<b>2</b>	Group photo after visit to construction site of City Rail Link Contract 1.	5
<b>3</b>	Presentation given by the Client of City Rail Link Contract 2.	5
<b>4</b>	Pipe-jacking TBM launching shaft for City Rail Link Contract 6.	6
<b>5</b>	Geological tour to volcanos in Auckland led by Mr. Phillip Kirk.	6
<b>6</b>	Earth bunds for slope production in Kaikoura.	7
<b>7</b>	Ohau Point – seal habitat in Kaikoura.	7
<b>8</b>	ANZAC bridge in Christchurch.	8
<b>9</b>	Visit to geotechnical laboratory and lecture in University of Canterbury.	8
<b>10</b>	Lecture on Canterbury Geotechnical Database.	9
<b>11</b>	Forming the NCTIR alliance for repair works in Kaikoura.	10
<b>12</b>	Active and passive solutions for Kaikoura repair works.	10
<b>13</b>	Flowchart (original sketch to final product) for the development of the Canterbury Geotechnical Database.	11
<b>14</b>	Augmented reality on 3D laser scanning of tunnel profile.	12
<b>15</b>	Comparison between stereoplots generated by machine	12
<b>16</b>	Drone with mounted LiDAR sensor.	13
<b>17</b>	Augmented reality in common digital devices.	13
<b>18</b>	Virtual reality	14
<b>19</b>	City Rail Link in Auckland.	14
<b>20</b>	Chief Post Office.	15
<b>21</b>	Underpinning of CPO columns.	16
<b>22</b>	Jet grout column between Diaphragm Wall panels.	16
<b>23</b>	Automated deformation monitoring system.	16
<b>24</b>	GIS model to identify basalt layer (pink colour in the borehole sticks)	17
<b>25</b>	Basaltic scoria.	17
<b>26</b>	Dynamic penetration test setup. (Cao et al 2013)	19
<b>27</b>	Gel-push sampler. (Jamiołkowski and Masella 2015)	19
<b>28</b>	Cyclic triaxial testing setup.	20
<b>29</b>	Torsional shear testing setup.	20

## 1. INTRODUCTION

The Hong Kong Institution of Engineers Geotechnical Division organized a technical visit to the North and South Islands of New Zealand between 2<sup>nd</sup> March 2019 and 9<sup>th</sup> March 2019. A total of 20 delegates of various background and level of experience (excluding organizing committee members and helpers) participated in this technical visit. This technical visit is funded by “Professional Services Advancement Support Scheme” under the Commerce and Economic Development Bureau.

## 2. OBJECTIVES OF TECHNICAL VISIT

The visit aims to enrich Hong Kong engineers’ knowledge on construction innovation such as machine learning, BIM, automation, drone photography, and smart technologies applied to infrastructure projects in Auckland and reconstruction for earthquake resilience after the 2011 Christchurch and 2016 Kaikoura earthquakes of Mw 6.2 and 7.8 respectively.

## 3. ITINERARY AND DETAILS OF ACTIVITIES

The technical visit comprises well-proportioned technical and networking activities. We first arrived at Auckland in the North Island of New Zealand, where we stayed until 5<sup>th</sup> March 2019. Then we took a domestic flight to Blenheim and embarked on a coach tour from Kaikoura towards Christchurch on 6<sup>th</sup> and 7<sup>th</sup> March 2019. Christchurch is the final destination and the group departed from New Zealand on 9<sup>th</sup> March 2019. Figure 1 presents the places visited on a satellite image of New Zealand.



**Figure 1:** Places visited in New Zealand.

### 3.1. Auckland

On the first day in Auckland, we spent the day exploring the city, for example visiting the well-known Mount Eden, where we enjoyed the panoramic view of the city and learned the impact of volcano eruptions. In the next two days (4<sup>th</sup> and 5<sup>th</sup> March), we visited the construction sites for Contracts 1, 2 and 6 of City Rail Link (Figures 2 to 4), which is a USD\$ 4.4 billion rail project currently under construction. We visited the project Northern Corridor Improvements, where we were given a tour by representatives of the alliance for this project. Our last activity in this city is attending a lecture and tour on the volcanic geology of Auckland given by Aurecon’s Lead Geologist (Figure 5), Philip Kirk, who is also a former geologist in Geotechnical Engineering Office in Hong Kong. We had a networking dinner at the top of the Sky Tower, which overlooks the mesmerizing night view of the city.



**Figure 2:** Group photo after visit to construction site of City Rail Link Contract 1.



**Figure 3:** Presentation given by the Client of City Rail Link Contract 2.



**Figure 4:** Pipe-jacking TBM launching shaft for City Rail Link Contract 6.



**Figure 5:** Geological tour to volcanos in Auckland led by Mr. Phillip Kirk.

### **3.2. Kaikoura**

After taking a domestic flight to Blenheim and having a networking lunch with local hosts in a local town area, we went on the coach tour and received an introduction by staff from North Canterbury Transport Infrastructure Recovery (NCTIR), Aurecon and Geological and Nuclear Sciences (GNS) on the ongoing recovery works after 2016 Kaikoura Earthquake.

We visited the NCTIR village which was built as accommodation for NCTIR staff from other places. We were given a presentation by NCTIR, Aurecon and GNS Science on the application of digital technology in the recovery works and were presented a variety of technology, such as drone photography, virtual reality, augmented reality, etc. We were given the opportunity to experience these technologies. During the coach tour along the Kaikoura highway, we saw various preventive measures against earthquakes. These include rockfall/debris catch fence, ship container used as a barrier against slope failure, mesh and bolting on slopes, hybrid earth bund and fences, etc. (Figure 5). We also stopped at Ohau Point (Figure 6) along the way to see a

seal colony that was recovered after the earthquake. In one evening, we had a local seafood dinner with the staff from GNS Science and Aurecon for networking with local engineers and scientists. The starry sky, distant from human light pollution, made most of us in awe, as we lack such privilege in our neon light home, Hong Kong.



**Figure 6:** Earth bunds for slope production in Kaikoura.



**Figure 7:** Ohau Point – seal habitat in Kaikoura.

### 3.3. Christchurch

Christchurch is our final destination, where the theme is on the rebuilding of the city after the devastating Christchurch earthquake in 2011. Dr Gabriel Chiaro from the University of Canterbury brought the group to visit some visible signs of damage inflicted by the earthquake 8 years ago. We went to the Christchurch Red Zone, a zone classified to be under a high risk of liquefaction in an earthquake effect. No structures have been built in the Red Zone after the 2011 earthquake and features in the landscape created by the earthquake, like changes in the topography, were visible. We also visited the ANZAC bridge (Figure 8), which was still suffering from a severe degree of damages, such as tilting of piers, significant cracks, and large displacement. In the afternoon, we were introduced a number of laboratory testing apparatus in the geotechnical laboratory of the University of Canterbury which were specifically designed to test the cyclic behavior of soil (Figure 9). In the

evening, we attended a lecture given by Tonkin-Taylor and New Zealand Geotechnical Society (Figure 10). The topic of the lecture focuses on the development of the Canterbury Geotechnical Database after the earthquake event. The database is a cloud system that aims to provide free access of information for engineers in their design to cope with earthquake hazards.

Overall, the itinerary comprises a well-balanced mix of activities, including lectures, geological tours, site visits as well as other leisure learning activities. This journey offers a great opportunity for the delegates to network and build friendships amongst themselves and with overseas counterparts. We were also able to communicate with local engineers of different backgrounds, including project managers, site engineers, geologists, researchers, etc. The trip has widened our perspective in different aspects, particularly in the application of technology, managing engineering risks and promoting sustainability.



**Figure 8:** ANZAC bridge in Christchurch.

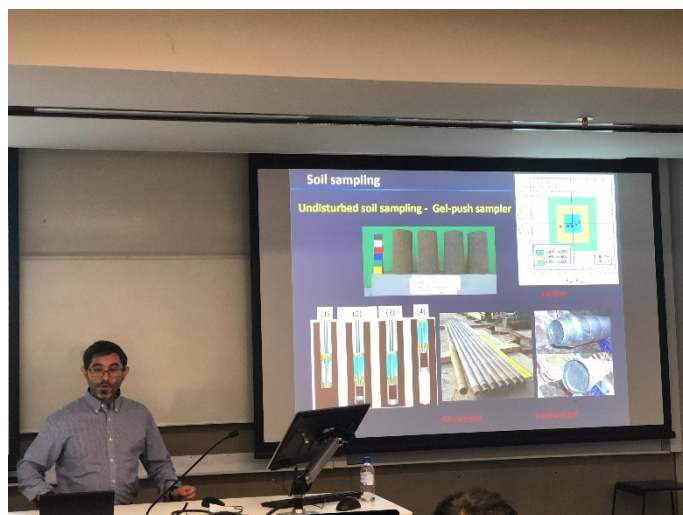

**Figure 9:** Visit to geotechnical laboratory and lecture in University of Canterbury.



**Figure 10:** Lecture on Canterbury Geotechnical Database.

## **4. KEY LEARNINGS AND TAKE-AWAYS**

The key learnings from the journey can be summarized into four main themes:

- (a) Adaptation in handling engineering challenges
- (b) Development and application of digital technologies
- (c) Construction, innovation and preservation
- (d) Advancement in geotechnical research for earthquakes

The insights gained upon these main themes are elaborated in the following sub-sections.

### **4.1. Adaptation in handling engineering challenges**





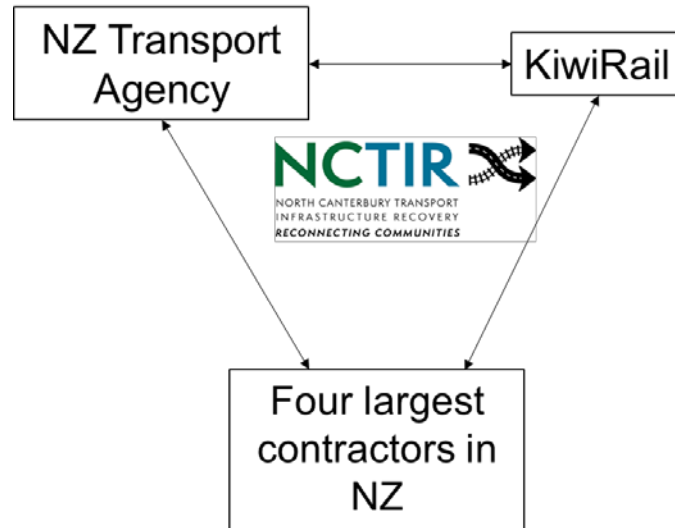

The word “adaptation” had been frequently highlighted throughout our visits to the cities that were once devastated by earthquakes, Kaikoura and Christchurch. The places were recovered, and subsequent measures taken to prevent or minimize the damage that may be caused by a similar incident illustrates the resilience of the community. The local engineers have provided solutions that gives the community confidence in the re-build and continuing development.

In Kaikoura, the earthquake resulted in the large landslides (>30), buildup of debris forming dams, damages of highways and >20 tunnels, rockfalls, etc. The estimated cost of repair was USD\$1.25 billion. NCTIR (Figure 11) was formed as an alliance between New Zealand Transport Agency, Kiwi Rail and the four largest contractors in New Zealand, in order to carry out recovery works in the region. The formation of the alliance helps to minimize disputes between the parties and align the objectives of different parties. It also enables the parties to have effective communications and efficient project delivery. This specific contractual relationship encourages the parties to work collaboratively to identify problems, derive solutions and achieve milestones of the project.



**Figure 11:** Forming the NCTIR alliance for repair works in Kaikoura.

As preventive and mitigation measures, the incident was managed by active and passive solutions. Active solutions refer to measures taken to reduce the risk of earthquake induced landslides, these include sluicing to remove loose material on slopes, meshing and bolting to stabilize slopes, etc. Passive solutions are measures to minimize damage if any landslides, debris flow or rockfalls occur. Rockfall/debris catch fences, hybrid fences and earth bund were installed to catch any falling material falling from the slopes. Special mention needs to be given to an innovative and cheap solution, which is the use of ship containers as a way to barricade falling materials from highways, railways or other harbor infrastructure. This solution is proven to be cheap and easy to construct. Therefore, it is an ideal solution for the Kaikoura repair works, which had an urgency to complete in order to restore normal functioning of the local community. Figure 12 shows a summary of measures implemented after the Kaikoura earthquake.

Active solutions	Passive solutions	
 <p data-bbox="379 1615 469 1641">Sluicing</p>	 <p data-bbox="651 1615 941 1641">Rockfall/debris catch fence</p>	 <p data-bbox="1075 1615 1251 1641">Ship containers</p>
 <p data-bbox="328 1852 517 1879">Mesh and bolting</p>	 <p data-bbox="735 1852 857 1879">Earth bund</p>	 <p data-bbox="1107 1852 1260 1879">Hybrid fences</p>

**Figure 12:** Active and passive solutions for Kaikoura repair works.

The final take-away from the Kaikoura experience on the topic of adaptation comes from their management of wildlife protection. Kaikoura is a renowned place for its natural habitats for a variety species. Whale and seal watching are popular activities in the area. The earthquake had undoubtedly devastated much of the habitats for these wild species. It is one of the main objectives to re-build their natural habitats and restore their original colour. It is undesirable that the recovery works would impose any further negative impact to them. Our coach guide from Aurecon and GNS science explained to the group the measures taken to work in harmony with the nature. Specific measures were taken to re-plant a certain type of local plant, known as Ohau Rock Daisy, and to minimize disruptions to the seal habitats. The destroyed seal habitats were re-built at new locations and the seals have been observed to recolonize at these new locations. The effort taken here to protect the nature reminds us the importance and benefits of sustainability.

Resilience is also illustrated in Christchurch. A group of engineers, led by Tonkin and Taylor, have established the Canterbury Geotechnical Database. The original idea comes from a rough sketch of a flow chart (Figure 13) drawn on a cardboard, which eventually transformed into a workable solution. The objective is to make best use of geotechnical data, accessible by all parties to enhance quality of engineering design. This is similar to the GInfo database in Hong Kong, which has been implemented over the years. It is inspiring to know that the same idea has spread across the Pacific Ocean. It highlights the importance of information access for geotechnical engineers to identify risks.

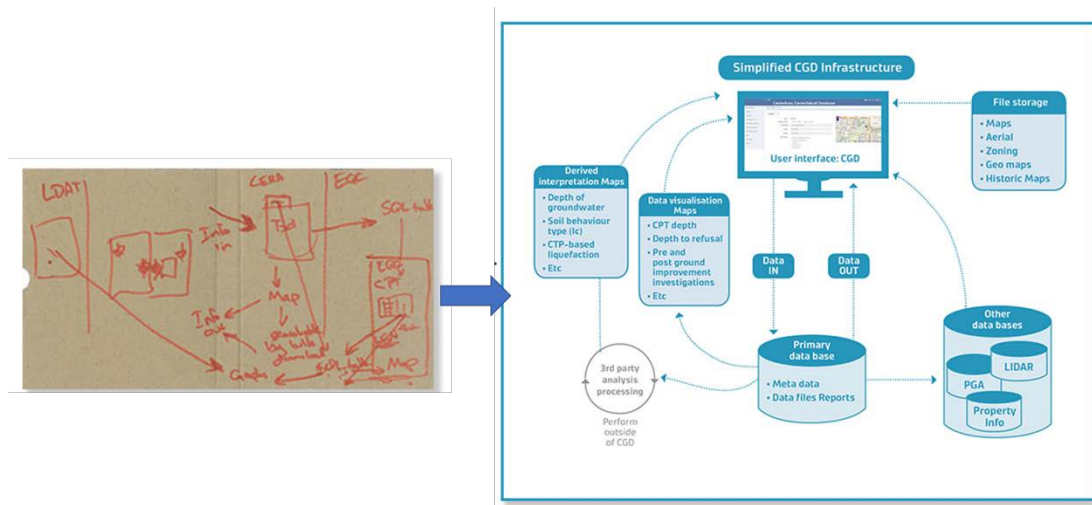

**Figure 13:** Flowchart (original sketch to final product) for the development of the Canterbury Geotechnical Database.

## 4.2. Development and application of digital technologies

As one of the themes of this visit is application of digital technologies, we received a lecture and a demonstration of digital technologies during our visit to Kaikoura. The advancement in digital technology application is unseen in Hong Kong practice. There is a large potential to apply these various technologies, to reduce cost and time and to identify and reduce risk.

In the lecture, representatives from GNS Science and Aurecon introduced to us how they have used various

technologies in their recovery works after the earthquake. They have used drones to carry out site reconnaissance, in order to minimize human entry to the site. As the site is still full of various hazards such as landslides or rockfalls, the use of drones improved the overall safety of the operation. They have also used photogrammetry/LiDAR and augmented reality to scan and digitize the profile of a tunnel to quantify the volume of overbreak or unexcavated portion (Figure 14). Using these technologies has minimized the disruption caused to the daily operation of the tunnel, as it takes significantly less time to complete the survey.

The application of digital technologies has extended to rock mapping. A comparison is shown between stereoplots based on mapped joints on the field and by photogrammetry. The one by photogrammetry identifies significantly more joints and therefore preserves more joint information (Figure 15). The one mapped on the field is more prone to missing information and human error.

The use of augmented reality or virtual reality has aided engineer’s communication with the stakeholders through an interactive process. For example, augmented reality on a sandbox is a versatile tool for users to shape any topography for communication purposes.



**Figure 14:** Augmented reality on 3D laser scanning of tunnel profile.

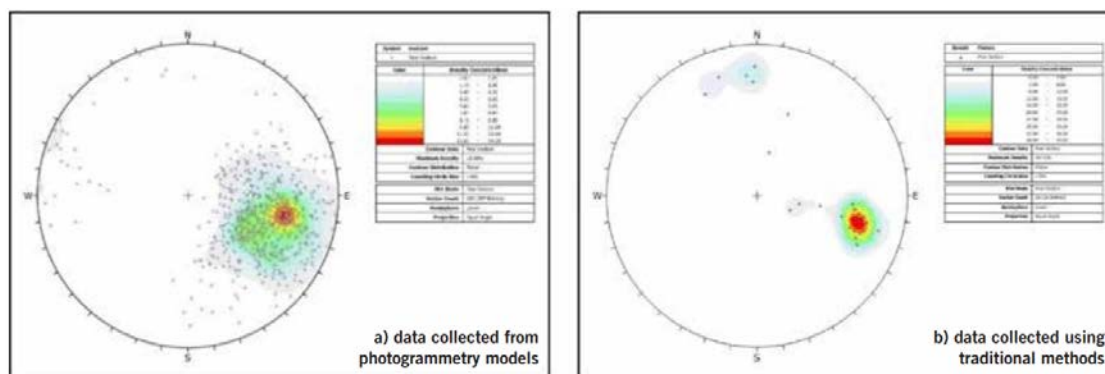

**Figure 15:** Comparison between stereoplots generated by machine

After the lecture, we were given a demonstration of the digital technologies, including drones mounted with LiDAR sensor (Figure 16), augmented reality with common digital devices (Figure 17), virtual reality (Figure 18), etc. A strong interest was shown amongst our group as most of us wished to apply these technologies in our work.

These technologies will bring about a revolutionary transformation to the engineering practice. They are able to improve health and safety as well as visualisation and communication. This is particularly useful in dense urban environment, as the public relation strategy for construction works can be improved by engaging in interactive communication with interested stakeholders using digital technologies. These technologies also help to preserve key information and aid design work with improved accuracy and reliability, which enhances engineers' capability to identify and mitigate risks. Overall, the lecture and demonstration gave us a good understanding on the application and benefits of digital technology.



**Figure 16:** Drone with mounted LiDAR sensor.



**Figure 17:** Augmented reality in common digital devices.



**Figure 18:** Virtual reality.

### 4.3. Construction, innovation and preservation

The third key learning is highlighted by three words, construction, innovation and preservation. The combination of these three elements yields a successful outcome in construction. We witnessed the effort made in achieving these three elements in the City Rail Link (CRL) Project in Auckland.

The CRL project (Figure 19) is the largest railway project currently in New Zealand with an estimated project sum of NZD\$ 4.4 billion. The scope involves the construction of railways and stations of 3.45 km in total length from Britomart to Mount Eden. The CRL will reduce the commute time in Auckland. The estimated time savings are summarized below:

- (a) 17 minutes between Henderson and Aotea
- (b) 9 minutes between Glen Innes and Aotea
- (c) 9 minutes between Papakura and Aotea
- (d) 10 minutes between Britomart and Mt Eden

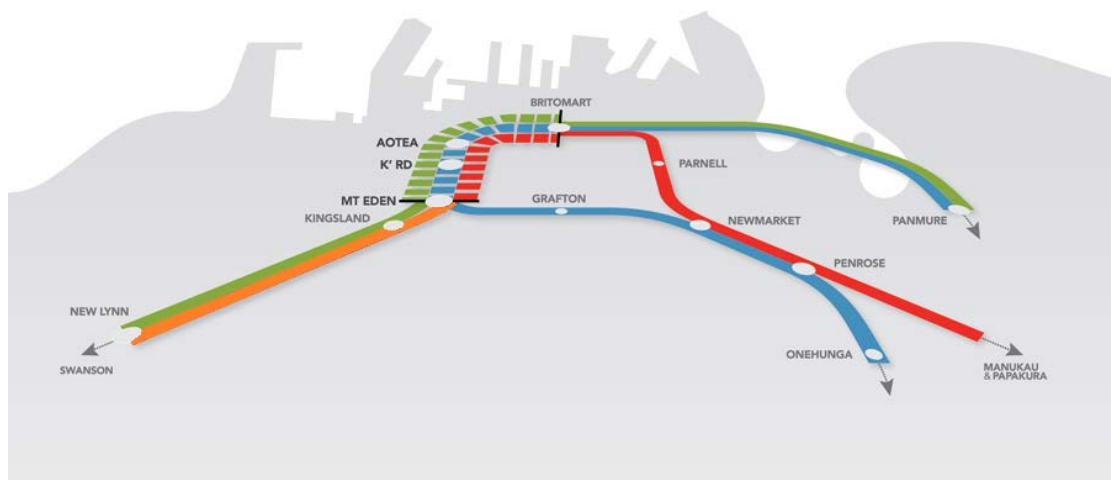

**Figure 19:** City Rail Link in Auckland

We visited a total of three sites, Contract 1, Contract 2 and Contract 6 of the CRL project. Each of these projects have its uniqueness.

The scope of Contract 1 involves the construction of tunnel station (expansion of the original Britomart Station) under the Chief Post Office (CPO, Figure 20) which is a 106-year-old Category 1-listed heritage building. On this, preservation of the heritage building is a key objective, but historical records of the foundation of the CPO was incomplete in the beginning. The challenge is to come up with a robust solution to carry out the station construction without inducing excessive differential settlement or vibration on the old building. Prior to excavation of the station box, the CPO was first underpinned, which involves connecting hydraulic load cells and support frames to the constructed diaphragm walls (Figure 21). The load from the CPO is transferred to the diaphragm walls such that the original foundation can be removed. The contractor had to use low-headroom equipment to carry out the construction within the CPO, and could not construct diaphragm walls next to existing columns and foundations due to limited space. They came up with the solution of installing jet grouted columns between the gap of diaphragm wall panels in these problematic areas (Figure 22). The CPO is constantly monitored by automatic deformation monitoring system (ADMS) which gives real-time measurement of the movement of the structure (Figure 23).



**Figure 20:** Chief Post Office.



**Hydraulic load cell and support frame**

**Figure 21: Underpinning of CPO columns.**

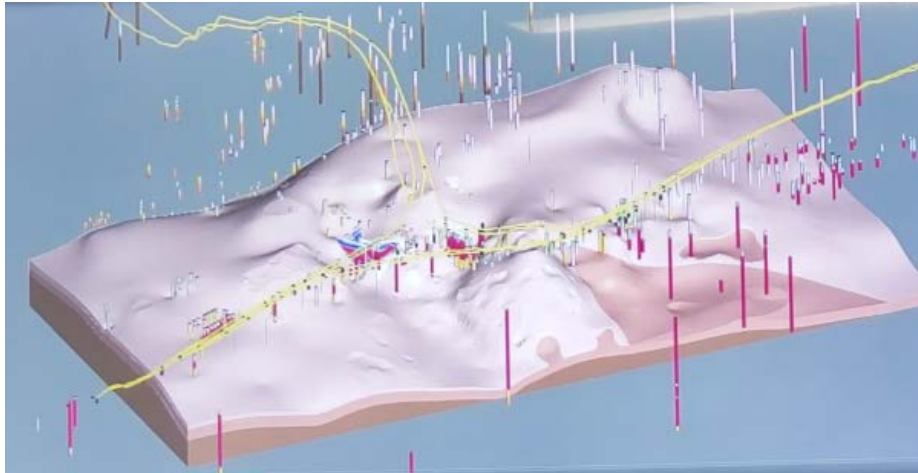

**Figure 22: Jet grout column between Diaphragm Wall panels.**



**Figure 23: Automated deformation monitoring system.**

Contract 2 involves the construction of a cut-and-cover tunnel along Albert Street with diversion of water mains. We visited the client's office and learnt about how building information modelling (BIM) and geographic information system (GIS) had been implemented for the project and how they helped to identify risks at an early stage. For example, they incorporated available ground investigation information into a 3D ground model (Figure 24) and identified the distribution and extent of the basalt layer, which was formed from a series of lava basalt flows and is typically difficult to break and excavate (Figure 25).



**Figure 24:** GIS model to identify basalt layer (pink colour in the borehole sticks).



**Figure 25:** Basaltic scoria.

Contract 6 is a micro-tunnelling project using pipe-jacking tunnel boring machine (TBM) for realignment of a stormwater pipe. A number of challenges have been encountered. The initial design involves construction of three shafts and two TBM runs in between the shafts. By allowing a larger curvature in the tunnel alignment, which is the largest ever achieved in micro-TBM tunneling, an alternative design with only two shafts was proven feasible. Cost and time saving could be achieved by the elimination of one shaft.

The contractor faced difficulties in the initial excavation of the shaft, where they encountered a layer of basalt. Typical mechanical breaking would result in very slow progress. They attempted an alternative measure by using drill and blast method. However, the results had not been satisfactory, and it posed a large risk of causing disturbance to the neighbourhood. Finally, they adopted the caisson sinking method, where the shaft is simultaneously excavated with the sinking of the shaft wall. This is an example of thinking out of the box as the caisson sinking method is typically carried out in soft ground conditions such that the shaft wall can sink under self-weight or with little jacking forces. The adoption of caisson sinking method in the basalt layer is unconventional, but it proves to be the most economic and effective method. In this example, it is valuable to learn about the alternative solutions that were undertaken in order to keep the project under budget and on schedule. The same challenges would be encountered in any part of the world and would probably be even bigger. Engineers should always keep an open mind and innovate through construction methods and designs.

#### **4.4. Advancement in geotechnical research for earthquakes**

The final theme of this trip focuses on the advancement in geotechnical research for earthquakes, which is a topic seldom touched in the Hong Kong Engineering field as earthquakes rarely occur. However, engineers should never limit their knowledge and skills by regional restraints and should always seek to apply their skills in other parts of the world. In particular, when the world is becoming more connected through global collaborations such as the one-belt-one-road initiatives, there will be more opportunities to work overseas for engineers. This is an interesting topic to many as most of us had little experience on dealing with earthquake related geotechnical problems. In Christchurch, we had a tour with Dr Gabriele Chiaro from University of Canterbury to the red zones in Christchurch. In this tour, as mentioned, he showed us the famous Anzac Bridge which had been severely damaged during the earthquake incident due to liquefaction and lateral spreading of the riverbank. It was a new sight for us to see a structure that heavily damaged and was still operating. During the tour, Dr Chiaro explained to us the new techniques that had been developed to carry out in situ seismic testing and to retrieve high quality samples for laboratory seismic testing. He explained the principles of dynamic penetration test (Figure 26) which is a combination of standard penetration test and cone penetration test. He also introduced a gel-push sampler (Figure 27) where gel is used as a lubricant for the sampler to be pushed in and to minimise contamination of soil by the drilling fluid. Ground freezing technique has also been adopted in obtaining undisturbed sampling.

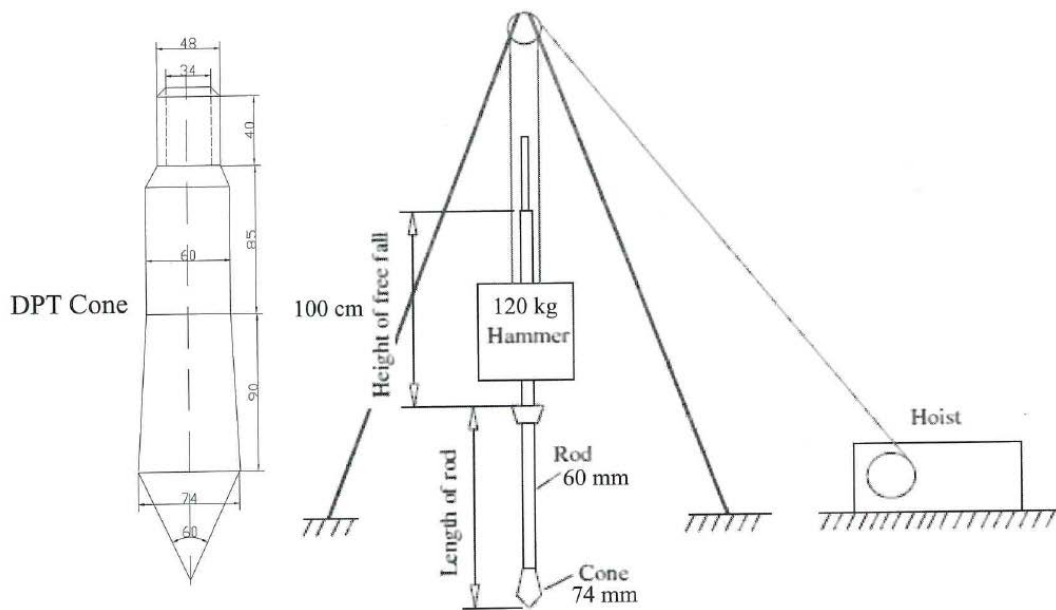

**Figure 26:** Dynamic penetration test setup. (Cao et al 2013)

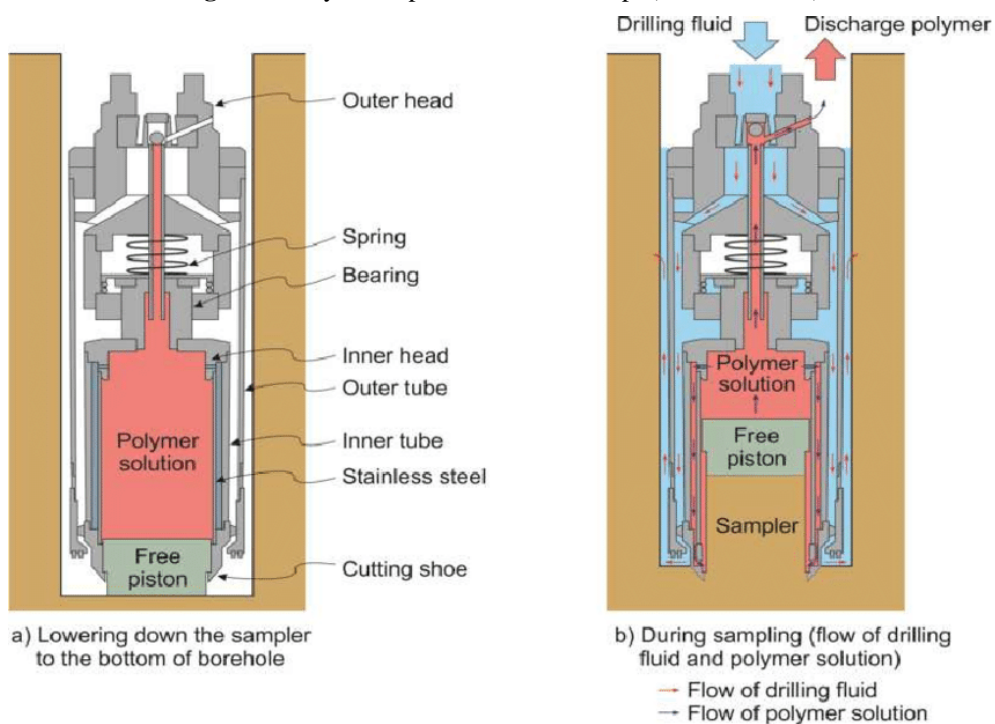

**Figure 27:** Gel-push sampler. (Jamiolkowski and Masella 2015)

After the tour, we visited the geotechnical laboratory of University of Canterbury. We were shown a number of testing apparatus to test the seismic behavior of soil. They include cyclic triaxial cell (Figure 28), torsional shear testing apparatus (Figure 29) and a large scale triaxial cell. Cyclic triaxial cell and torsional shear testing apparatus can be used to test the cyclic behavior under different shear mode for typical soil sample. The large scale triaxial cell, which we were not allowed to take photos of, can test samples with particle size as large as gravels.

The geotechnical research in University of Canterbury has been undertaken through close collaboration with various parties including local and foreign consultancy firms and overseas universities. The collaboration facilitates the process to bring in new techniques and technology to the industry and encourages research to be developed on handling geotechnical hazards.



**Figure 28:** Cyclic triaxial testing setup.



**Figure 29:** Torsional shear testing setup.

## 5. CONCLUSIONS

This trip is packed with opportunities to learn and is eye-opening to many of us, especially those who are still young in the civil engineering field. It is well-balanced with educational activities and leisure/social networking activities. We met and made exchanges with the local engineers. The natural environment there is world-class and seeing that the engineering practice there has generally be undertaken in harmony with the nature is both stimulating and inspirational.

We visited three places in New Zealand. They are Auckland, Kaikoura and Christchurch. We had a variety of activities, including lectures, site visits, geological field trips and university visits, etc. These activities cover a wide range of topics in civil engineering, such as earthquake recovery works, urban construction, geology. There are plenty of opportunities to meet and talk to engineers, project managers, and researchers.

Our learnings from this trip can be summarized into four main themes:

- (a) Adaptation in handling engineering challenges
- (b) Development and application of digital technologies
- (c) Construction, innovation and preservation
- (d) Advancement in geotechnical research for earthquakes

Each of these themes is very relevant to our own practice and is very beneficial. They widen our horizon and enrich our knowledge as we had less experience in some aspects of their work, like geotechnical problems related to earthquake and digital engineering. These experiences motivate us to innovate in our work and to explore alternatives, in particular the application of digital engineering.

Finally, the HKIE Geotechnical Division would like to thank the PASS funding PS182009 to make this wonderful trip possible.

## REFERENCES

Cao, Z., Youd, T. L., & Yuan, X. (2013). Chinese dynamic penetration test for liquefaction evaluation in gravelly soils. *Journal of geotechnical and geoenvironmental engineering*, 139(8), 1320-1333.

Jamiolkowski, M., & Masella, A. (2015). Geotechnical characterization of copper tailings at Zelazny Most Site. Keynote Lecture, DMT, 15, 25-42.

## ACKNOWLEDGEMENT

此刊物／本項目由香港特別行政區政府「專業服務協進支援計劃」撥款資助。

This material/event is funded by the Professional Services Advancement Support Scheme of the Government of the Hong Kong Special Administrative Region.

在此刊物／本項目的任何活動中提出的任何意見、研究成果、結論或建議，並不代表香港特別行政區政府及專業服務協進支援計劃評審委員會的觀點。

Any opinions, findings, conclusions or recommendations expressed in this material/any event organised under this project do not reflect the views of the Government of the Hong Kong Special Administrative Region or the Vetting Committee of the Professional Services Advancement Support Scheme.