

# SINOCONVE CONVEYOR ROLLER CATALOG



**PT GLOBAL SINDO PERKASA**

Whatsapp : +62 812 8778 6884

Email : [gsp.sales@global-sindo.com](mailto:gsp.sales@global-sindo.com)

# CONTENTS

COMPANY INTRODUCTION-----	P1
PRODUCT STRUCTURE-----	P2
STEEL IDLER ROLLER-----	P3-P4
SHAFT ENDS TYPES-----	P5-P12
ROLLER PARTSS-----	P13
STEEL ROLLER SURFACE TREATMENT-----	P14
PRODUCT SELF-CHECK SYSTEM-----	P15
PACKAGE-----	P16
IMPACT IDLER ROLLER-----	P17--P18
RETURN IDLER ROLLER-----	P19--P24
GARLAND IDLER ROLLER-----	P25--P26
IDLER ROLLER BRACKET-----	P27--P29



# COMPANY INTRODUCTION

**SINOCONVE BELT CO., LTD** is located at the beautiful city of East sea of China. It enjoys convenient transportation. The company was founded in 1988. It covers an area of 200,000 m<sup>2</sup> with over 200 workers, 26 engineers. It has the most advanced Conveyor roller production lines and has an annual output of 80 thousand pieces of Conveyor roller each year. Product exported can reach 40%.



Our company produce the products in accordance with China national standards organization. The quality comes up to advanced national technology standards. Product is sold to domestic market and exported to the United States, Europe, Middle East, Africa and Southeast Asia, etc.

We have advanced equipment and excellent management team, through technical innovation and management innovation to enhance the competitiveness of enterprises, to maintain a strong competitive position in the domestic Conveyor accessories industry, and to catch up with the world advanced level.



## PRODUCT STRUCTURE

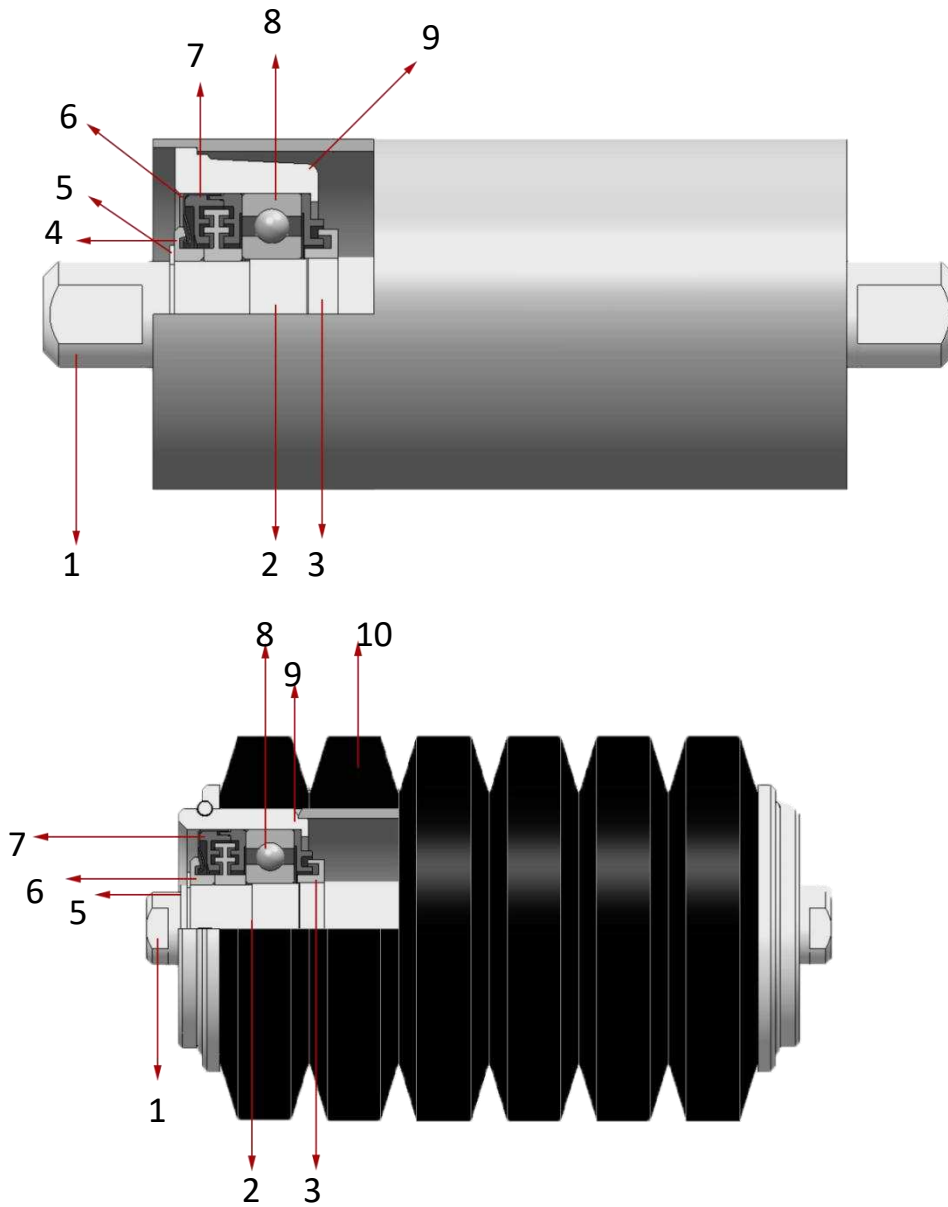

**SINOCONVE** roller are designed and manufactured with the national standard, which have the performance of water-proof, dust-proof, minimum rotation resistance and high resistance to vandalism.

1	Cold drag axle	6	First layer of sealing
2	Steel wire	7	Second layer of sealing
3	Cir clip for axle	8	Bearing
4	Cover	9	Bearing housing
5	Cir clip for axle	10	Strong anti-tearing rubber ring



# STEEL IDLER ROLLER

**SINOCONVE** idler roller is the competitive standard for belt conveyors. The idler is used as a carrying idler and also as a return idler for non-sticky materials.

The steel sealed shell and weatherproof seal form a reliable splash protection. Multiple seals effectively prevent dust from entering the inside of the drum. The surface of the drum is shot blasted and covered with a red epoxy powder coating. If you want to deal with viscous materials, you can carry out special surface treatment.

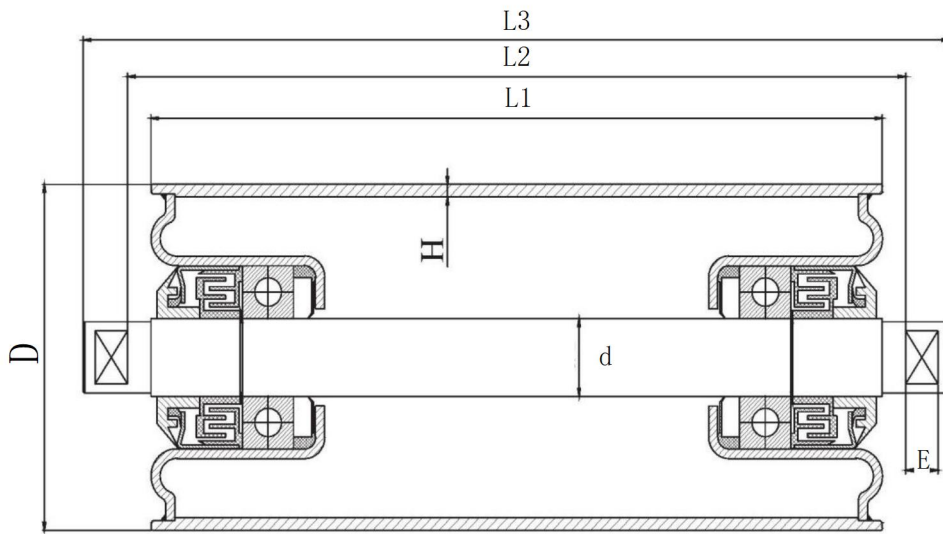

DIMENSIONS(mm)	
<b>L1</b>	150-3000/Customize
<b>D</b>	89,108,133,159,194/Customize
<b>d</b>	28,38,48,58/Customize
<b>H</b>	5-11/Customize







## STEEL IDLER ROLLER







**SINOCONVE** provides professional roller products, the following is our conventional steel roller model table.

Conveyor Idler Roller Size				
Standard Diameter		Length scope ( mm)	Bearings Type (Min~Max)	Idler's Shell Wall Thickness
mm	In			
6.35	$2\frac{1}{2}$	1500-1400	204	3.0-3.75mm
76	3	150-3000	204,205	3.0-4.0mm
89	$3\frac{1}{3}$	150-3000	204,205	3.0-4.0mm
102	4	150-3000	204,205,305	3.5-4.0mm
108	$4\frac{1}{4}$	150-3000	204,205,305,306	3.5-4.0mm
114	$4\frac{1}{2}$	150-3000	205,206,305,306	3.5-4.5mm
127	5	150-3000	204,205,305,306	3.5-4.5mm
133	$5\frac{1}{4}$	150-3000	205,206,207,305,306	3.5-4.5mm
140	$5\frac{1}{2}$	150-3000	205,206,207,305,306	3.5-4.5mm
152	6	150-3000	205,206,207,305,306,307,308	4.0-4.5mm
159	$6\frac{1}{2}$	150-3000	205,206,207,305,306,307,308	4.0-4.5mm
165		150-3000	207,305,306,307,308	4.5-6.0mm
177.8		150-3000	205,306,307,308,309	4.5-6.0mm
190.7		150-3000	207,306,307,308,309	4.5-6.0mm
194	$7\frac{5}{8}$	150-3000	207,307,308,309,310	4.5-6.0mm
219	$8\frac{5}{8}$	150-3000	308,309,310	4.5-6.0mm

**Besides we can manufacture the idlers and rollers according to the buyer's requirements**

# SHAFT ENDS TYPES

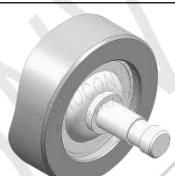
	<b>Type</b>	A
	<b>Description</b>	
	Outer Double Flat	
	<b>Type</b>	C
	<b>Description</b>	
	Round With A Hole For Connection In Garland	
	<b>Type</b>	E
	<b>Description</b>	
	Outer Double Flat & Inner Single Flat	
	<b>Type</b>	G
	<b>Description</b>	
	Inner Single Flat	
	<b>Type</b>	I
	<b>Description</b>	
	Outer Double Flat & Inner Double Flat	
	<b>Type</b>	K
	<b>Description</b>	
	Outer Thread & Outer Double Flat	
	<b>Type</b>	M
	<b>Description</b>	
	Round With A Slotted Hole	

	<b>Type</b>	B
	<b>Description</b>	
	Inner Double Flat	
	<b>Type</b>	D
	<b>Description</b>	
	Outer Double Flat	
	<b>Type</b>	F
	<b>Description</b>	
	Outer Single Flat	
	<b>Type</b>	H
	<b>Description</b>	
	Round With A Hole	
	<b>Type</b>	J
	<b>Description</b>	
	Inner Round Reduced	
	<b>Type</b>	L
	<b>Description</b>	
	Outer Double Flat With A Gutter For The Socket	
	<b>Type</b>	N
	<b>Description</b>	
	Round With Inner Double Notch	



## SHAFT ENDS TYPES

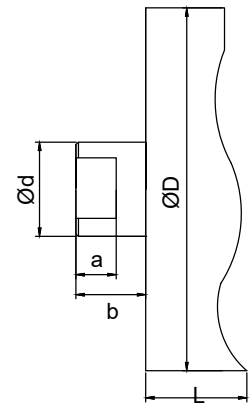
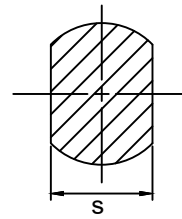

### OUTER DOUBLE FLAT

Data	Bearing Type			
	6306	6308 22308	6310	6312 22312
Ød(max)	28	38	48	58
ØD	89,108,133	108,133,159	133,159	159,194

Dimensions s, a and b at the request of the customer

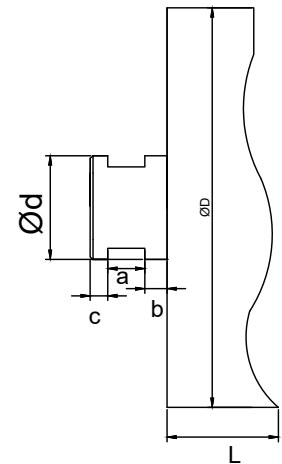
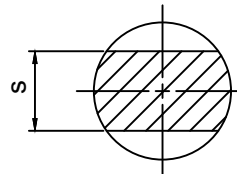

### INNER DOUBLE FLAT

Data	Bearing Type			
	6306	6308 22308	6310	6312 22312
Ød(max)	28	38	48	58
ØD	89,108,133	108,133,159	133,159	159,194

Dimensions s, a, b and c at the request of the customer

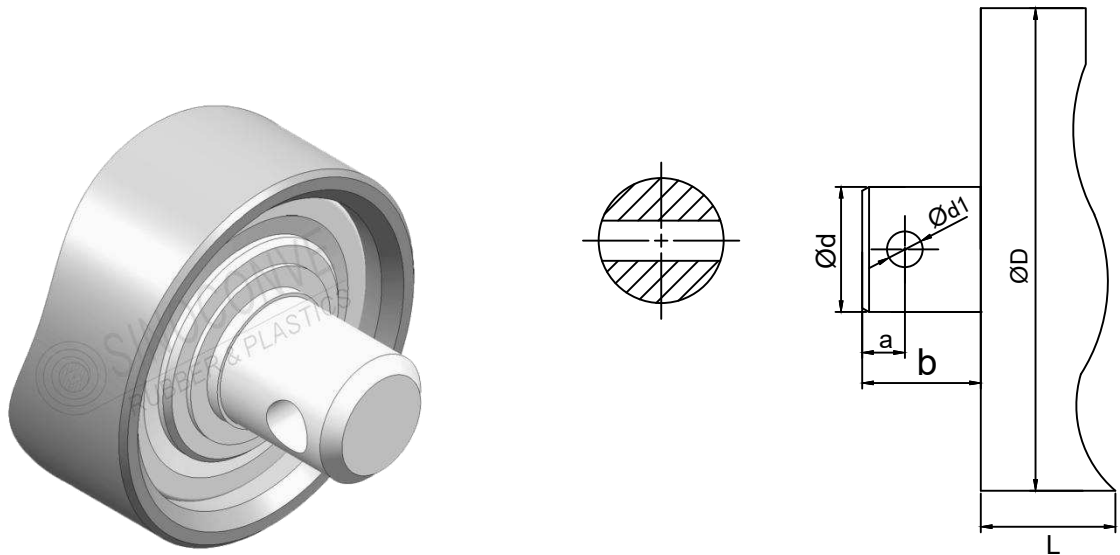

ROUND WITH A HOLE FOR CONNECTION IN GARLAND				
Data	Bearing Type			
	6306	6308	6310	6312
$\varnothing d(\text{max})$	28	38	48	58
$\varnothing D$	89,108,133	108,133,159	133,159	159,194

Dimensions  $d_1$ ,  $a$  and  $b$  at the request of the customer

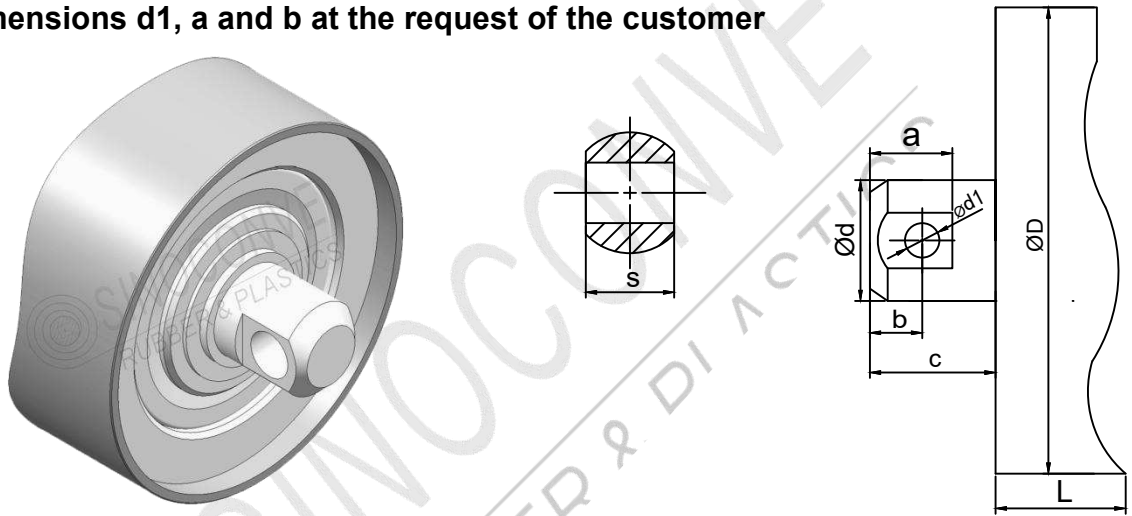

OUTER DOUBLE FLAT				
Data	Bearing Type			
	6306	6308	6310	6312
$\varnothing d(\text{max})$	28	38	48	58
$\varnothing D$	89,108,133	108,133,159	133,159	159,194

Dimensions  $d_1$ ,  $s$ ,  $a$ ,  $b$  and  $c$  at the request of the customer

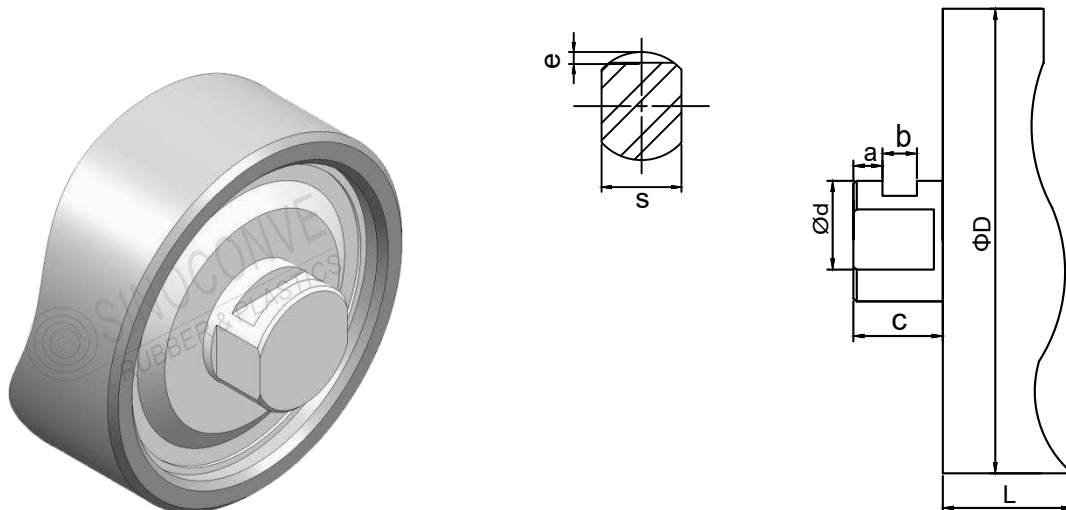

OUTER DOUBLE FLAT & INNER SINGLE FLAT				
Data	Bearing Type			
	6306	6308	6310	6312
$\phi d(\text{max})$	28	38	48	58
$\phi D$	89,108,133	108,133,159	133,159	159,194

Dimensions a, b, c, e and s at the request of the customer

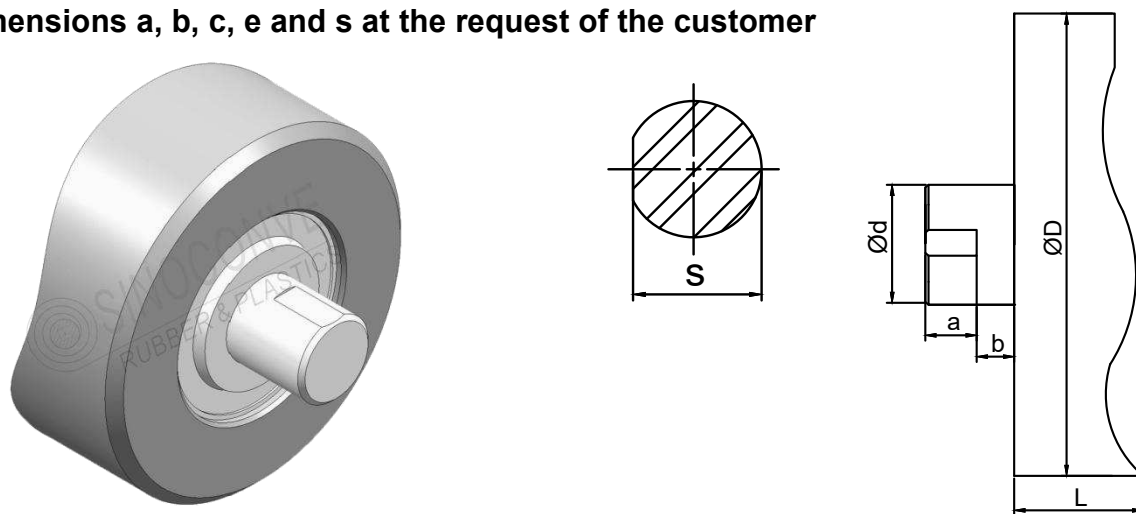

OUTER SINGLE FLAT				
Data	Bearing Type			
	6306	6308	6310	6312
$\phi d(\text{max})$	28	38	48	58
$\phi D$	89,108,133	108,133,159	133,159	159,194

Dimensions a, b and s at the request of the customer



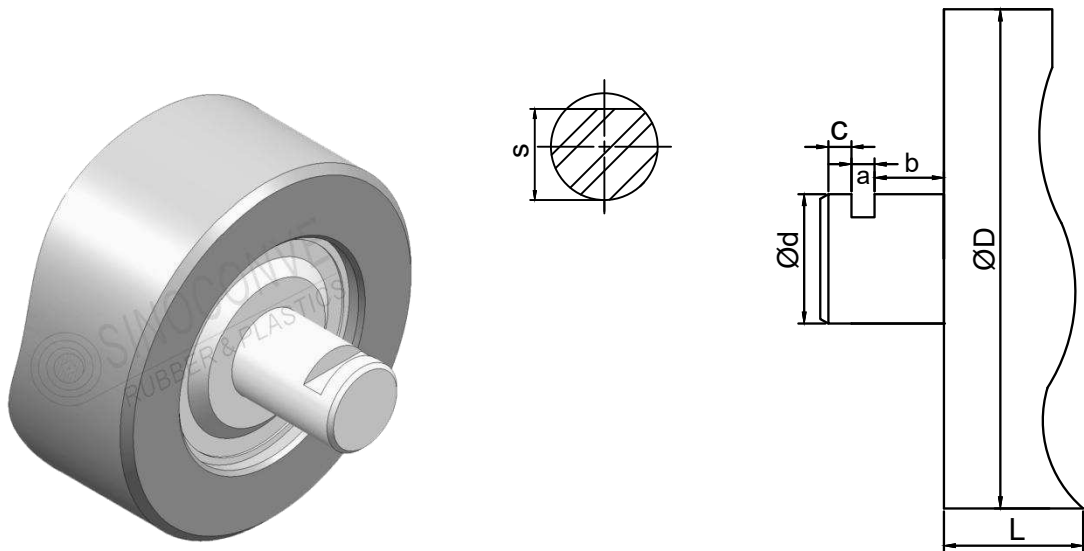

INNER SINGLE FLAT				
Data	Bearing Type			
	6306	6308	6310	6312
Ød(max)	28	38	48	58
ØD	89,108,133	108,133,159	133,159	159,194

Dimensions a, b, c and s at the request of the customer



ROUND WITH A HOLE		
Data	Bearing Type	
	6306	6308
Ød(max)	28	38
ØD	89,108,133	108,133

Dimensions Ød1, a, b and f at the request of the customer

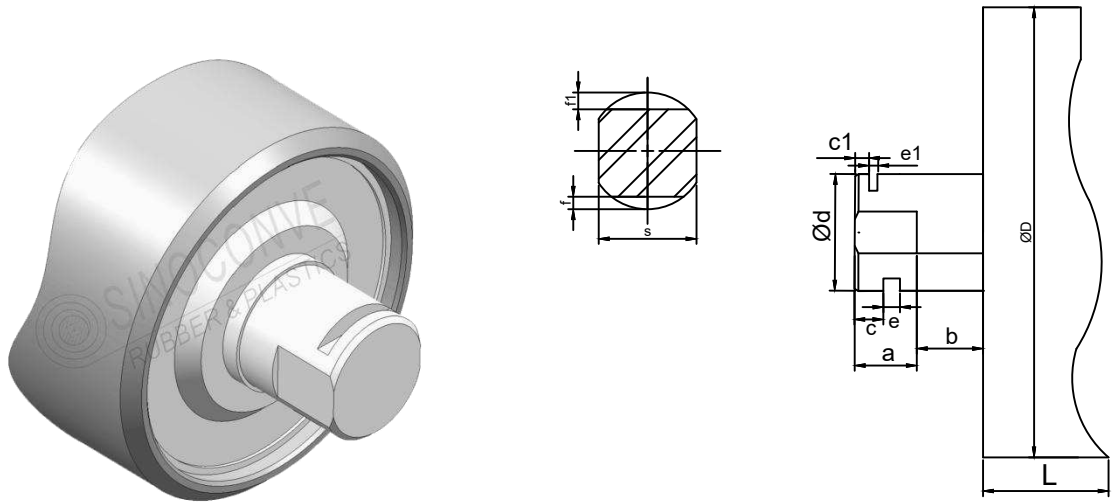

OUTER DOUBLE FLAT&INNER DOUBLE FLAT				
Data	Bearing Type			
	6306	6308	6310	6312
Ød(max)	28	38	48	58
ØD	89,108,133	108,133,159	133,159	159,194

Dimensions a, b, c, e, c1, e1, f and f1 at the request of the customer

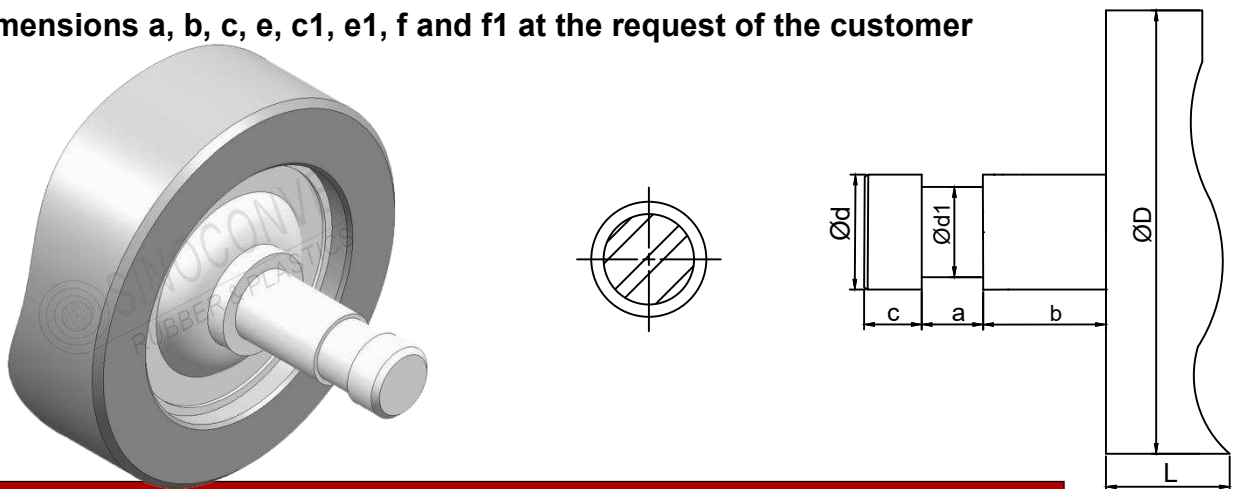

INNER ROUND REDUCED	
Data	Bearing Type
Ød	20
Ød1	17.5
ØD	89,108,133

Dimensions a, b, and c at the request of the customer

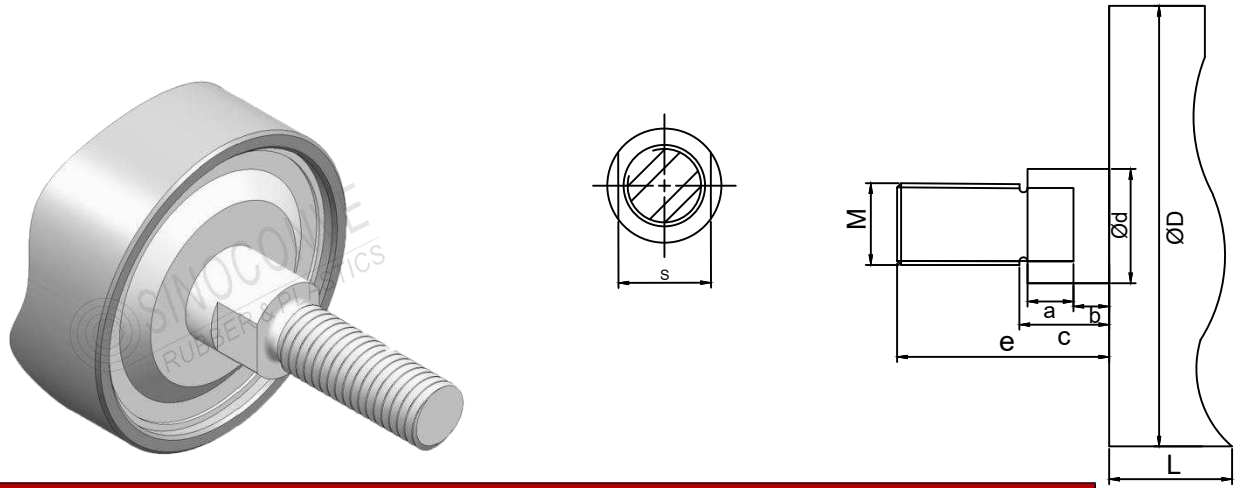

<b>OUTER THREAD&amp;OUTER DOUBLE FLAT</b>	
Data	Bearing Type
	6306
<b>Ød(max)</b>	28
<b>M</b>	20
<b>s</b>	24
<b>ØD</b>	89

❖ Dimensions s, a and b at the request of the customer

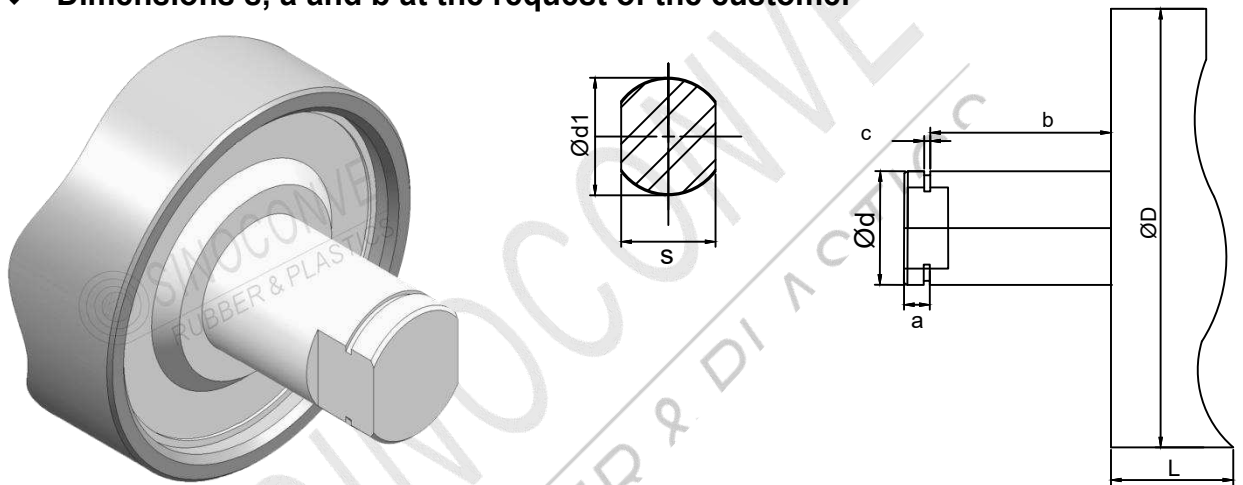

<b>OUTER DOUBLE FLAT WITH A GUTTER FOR THE SOCKET</b>				
Data	Bearing Type			
	6306	6308	6310	6312
<b>Ød(max)</b>	28	38	48	58
<b>ØD</b>	89,108,133	108,133,159	133,159	159,194

❖ Dimensions s, a and b at the request of the customer



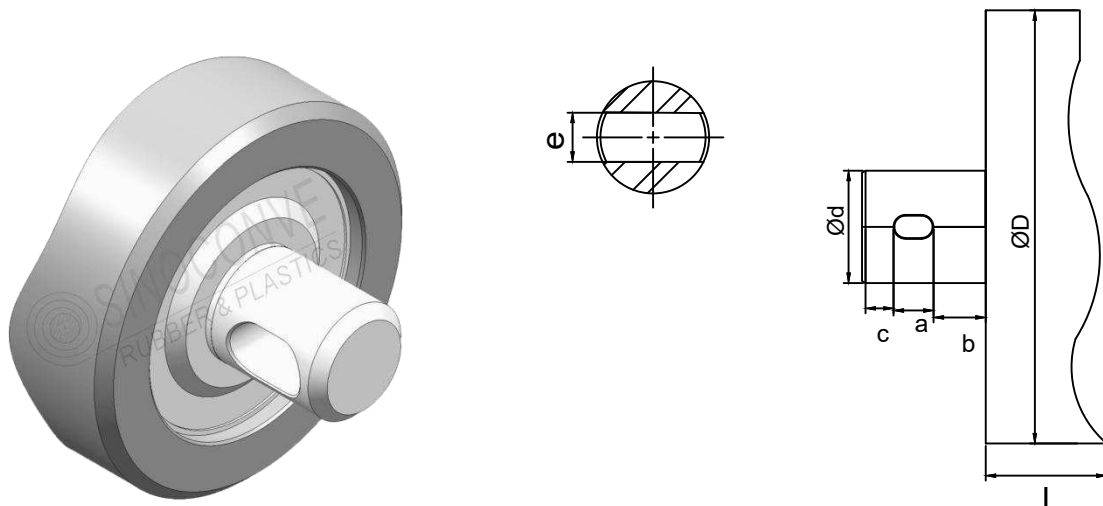

ROUND WITH A SLOTTED HOLE				
Data	Bearing Type			
	6306	6308	6310	6312
Ød(max)	28	38	48	58
ØD	89,108,133	108,133,159	133,159	159,194

❖ Dimensions s, a and b at the request of the customer

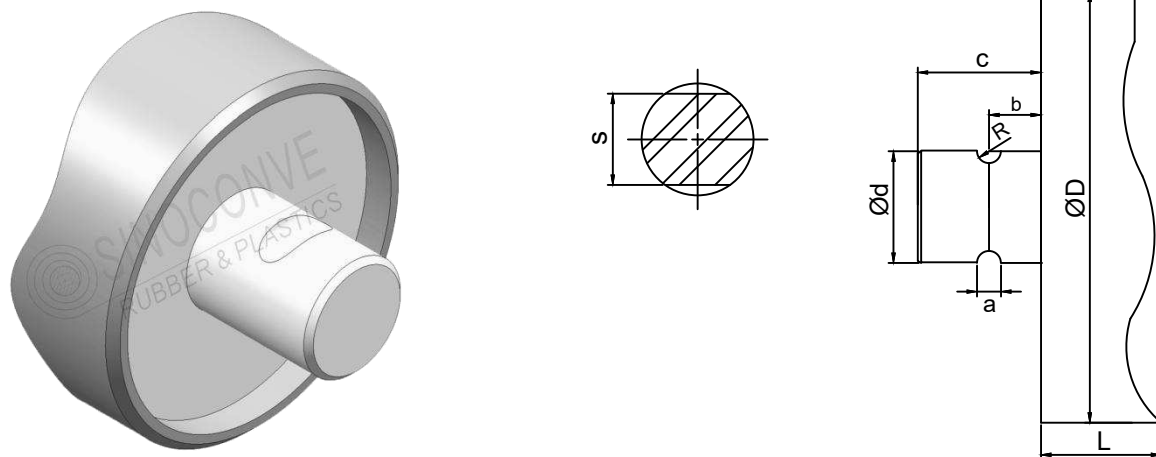

ROUND WITH INNER DOUBLE NOTCH				
Data	Bearing Type			
	6306	6308	6310	6312
Ød(max)	28	38	48	58
ØD	89,108,133	108,133,159	133,159	159,194

❖ Dimensions s, a and b at the request of the customer

# ROLLER PARTS

## BEARING HOUSING

**SINOCONVE** Bearing housings are produced by the technology of stamping & pressing. Till now we have three types of bearing housings, which have their own specific respectively, thus, they could satisfy the requirements of different customers, and environmental requirements of different industries



## BEARING HOUSING

**SINOCONVE** Bearing are applying with large clearance, Deep groove ball bearings, which can protect and guarantee the rollers with the ideal static and dynamic balance. Bearings either with double dust proof cover or with double Labyrinth ring will ensure rollers running smoothly to the maximum extend. Currently the bearing we used is HRB and SKF.

## SEALING

**SINOCONVE** use the multiple layer seal, and rush into lithium lubricating grease in the seal. The bearing oil loading is about 2/3-3/4 of the bearing clearance, the clearance between the seal rings are fully loaded. This way guarantees the enclosed and the compact endless of the seals and achieved the effectiveness of dust proof and water proof and the bearing protection.



## STEEL ROLLER SURFACE TREATMENT



**SINOCONVE** uses sandblasting to remove rust from steel pipes. After sandblasting to remove rust, the surface of the steel pipe will be painted more evenly.

There are two processes for **SINOCONVE** roller paint: **spray paint** and **baking paint**.

Spray Paint roller, the price is lower than the baking paint roller. The surface of the baking paint roller is smoother, and the surface of the spray paint roller is prone to defects





# PRODUCT SELF-CHECK SYSTEM



Idler steel tube thickness measuring



Ultrasonic Fault Detector



Idler external circular radial run out



Idler dust proof tester

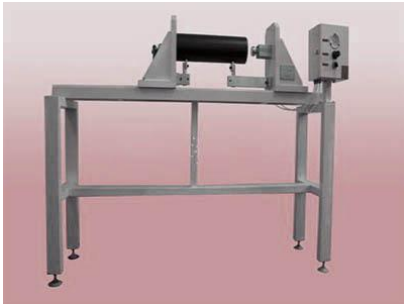

Idler axial displacement tester



Idler waterproof tester



Idler drop test method



Idler Rotating resistance tester

# PACKAGE

**SINOCONVE** Idler roller will be put into the matched plastic bag, then packed in the wooden case, all of the wooden cases will be fumigated before loading to ensure the wooden case comply with the hygienic standard.



## Packaging display

**Wooden packing case**



**Iron box packing**



# IMPACT IDLER ROLLER

**SINOCONVE** impact idler roller to absorb impact shocks at belt conveyor loading points. The impact idler roller is also suitable for a snub pulley for the dirty side of the belt as well as for an impact idler for unit goods conveyors.

**SINOCONVE** impact idler roller is based on the sturdy **SINOCONVE** steel idler roller. By adding rubber support ring to achieve the cushioning effect

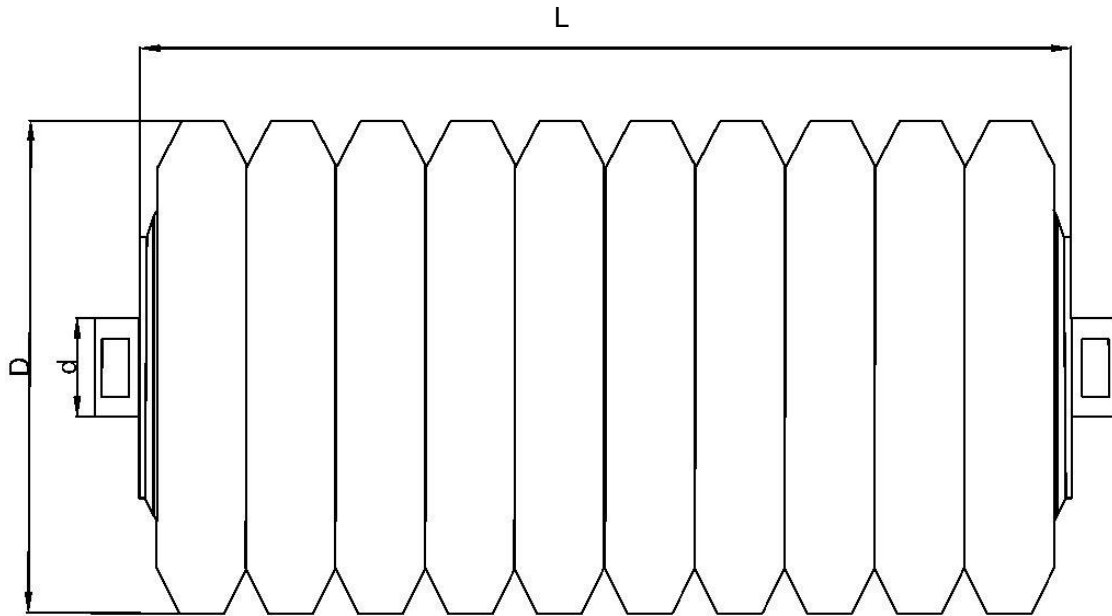

D(mm)	d(mm)	L(mm)
89	20	250-2000
	25	
108	20	
	25	
133	20	
	25	
	30	
159	20	
	25	
	30	
219	30	
	40	

In addition, we can customize according to the buyer's requirements.

## IMPACT IDLER ROLLER SUPPORT

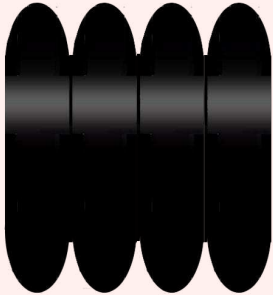

**A-type Support Ring Features:**  
(1) Small contact area,  
(2) Good elasticity

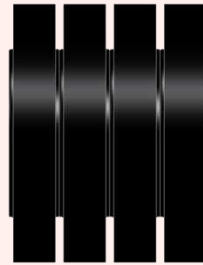

**B-type Support Ring Features:**  
(1) Good abrasion resistance  
(2) Wide contact surface  
(3) Good wear resistance

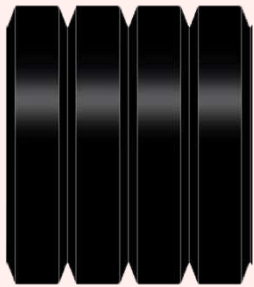

**C-type Support Ring Features:**  
(1) Wide contact surface  
(2) Good wear resistance  
(3) Not easy to move

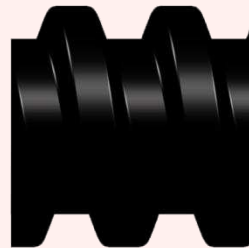

**D-type Support Ring Features:**  
(1) Good flexibility  
(2) Impact resistance

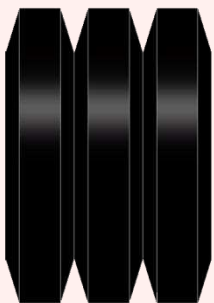

**E-type Support Ring Features:**  
(1) Wide contact surface  
(2) Good elasticity

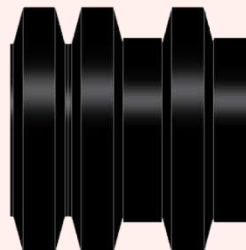

**E-type with spacing rings Features:**  
(1) Wide contact surface  
(2) Good wear resistance  
(3) Not easy to move



## RETURN IDLER ROLLER

**SINOCONVE** Return idler roller are designed to support the return belt. The selection of the return idler type is influenced by the strength, stiffness and weight of the belt.

Return idler roller are installed on the unloaded branch to support the conveyor belt on the branch. In the common layout, the use of V-shaped or reverse V-shaped support in the lower unloaded section is beneficial to restrain the deviation of the conveyor belt.

Besides the rubber disc types A and B (ISO, SMS and SFS standards) return idlers can be equipped with polyurethane discs. Tailor-made support ring assembly types are also available.

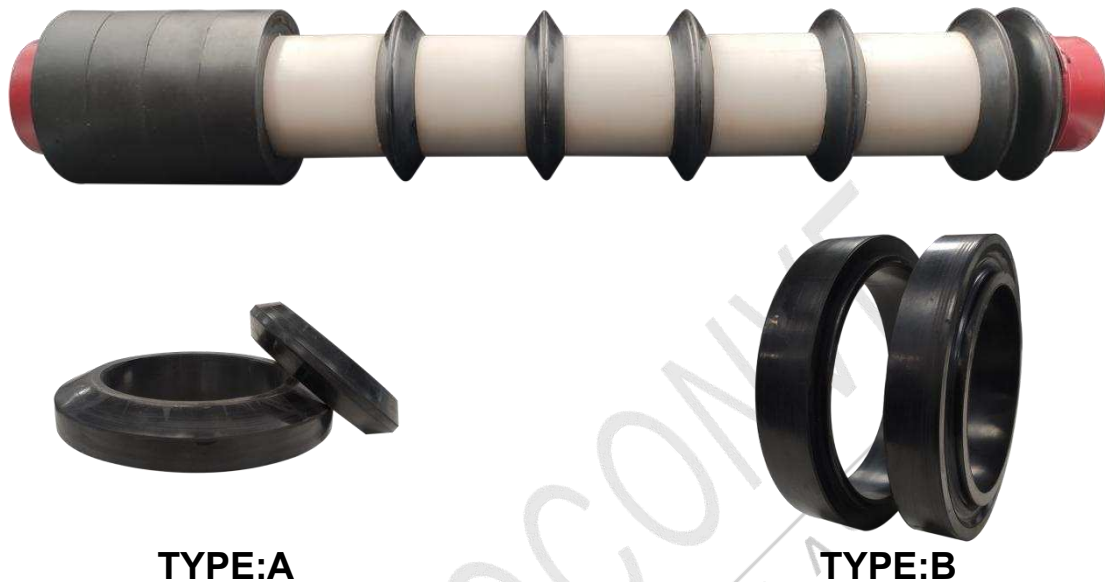

### Return Steel idler roller

SINOCONVE idler roller are used for belts that are clean and non-sticky. It is also available with rubber lagging (5 mm or 10 mm) and can be used as a impact roller. They are also used on both sides of the pressing guide bracket and as a counter idler for the cleaner..

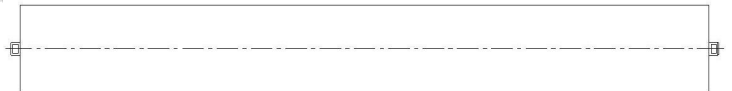

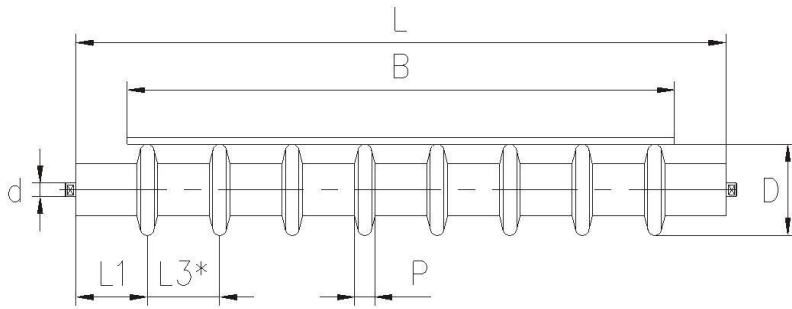

### Return A type idler roller

Distance between support ring is equal. The idler is for light, stiff belts with short distances between idlers.

L	B	D	P	L1	L3	Support ring(pcs)
500	400	108	25	58	96	5
		133	30			
		159	30			
600	500	108	25	60	96	6
		133	30			
		159	30			
750	650	108	25	47	106	7
		133	30			
		159	30			
950	800	108	25	104	106	8
		133	30			
		159	30			
1150	1000	108	25	95	116	9
		133	30			
		159	30			
1400	1200	108	25	120	126	10
		133	30			
		159	30			
1600	1400	133	30	120	136	11
		159	30			
1800	1600	133	30	120	136	12
		159	30			
2000	1800	133	30	120	136	14
		159	30			
2200	2000	133	30	120	136	15
		159	30			

For technical reasons in production the discs may be differently spaced in the middle of the idler.

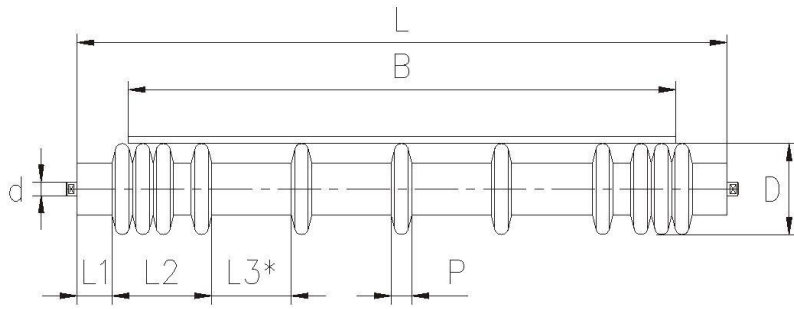

### Return A( II ) type idler roller

The support ring is more closely distributed at both ends of the roller. The support ring makes the outer area of the belt tightly packed. This support ring arrangement reduces the lateral drift of the conveyor belt and ensures the smooth running of the belt.

L	B	D	P	L1	L2	L3	Support ring(pcs)
500	400	108	40	50	100	80	5
		133	40				
		159	40				
600	500	108	40	50	105	125	5
		133	40				
		159	40				
750	650	108	40	50	110	110	6
		133	40				
		159	40				
950	800	108	40	60	155	145	8
		133	40				
		159	40				
		219	50	60	190	115	8
1150	1000	108	40	60	155	150	9
		133	40				
		159	40				
		219	50	60	190	125	9
1400	1200	108	40	65	195	145	12
		133	40				
		159	40				
		219	50	70	195	135	10
1600	1400	133	40	70	195	145	13
		159	40				
		219	50	70	200	135	11
1800	1600	133	40	60	200	145	14
		159	40				
		219	50	70	195	140	12
2000	1800	133	40	60	200	150	15
		159	40				
		219	50	70	195	140	13
2200	2000	133	40	60	200	150	16
		159	40				
		219	50	70	195	140	14

technical reasons in production the discs may be differently spaced in the middle of the idler.

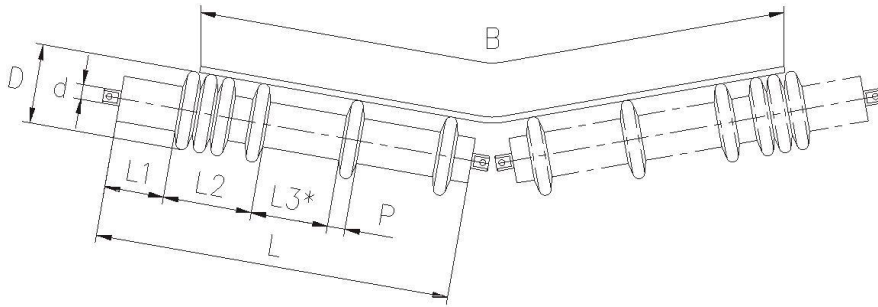

### Return A( II ) type idler roller

Used for wide and light belts. In the common layout, the use of V-shaped or reverse V-shaped support in the lower unloaded section is beneficial to restrain the deviation of the conveyor belt.

L	B	D	P	L1	L2	L3	Support ring(pcs)
380	650	108	25	70	121	111	5
		133	30	70	146	106	5
		159	30				
465	8000	108	25	70	121	101	6
		133	30	70	146	146	5
		159	30				
600	1000	108	25	100	171	121	8
		133	30	110	146	116	6
		159	30				
670	1200	108	25	60	171	111	9
		133	30	60	176	166	7
		159	30				
		219	40	50	196	146	6
750	1400	133	30	45	176	136	8
		159	30				
		219	40	35	196	126	7
900	1600	133	30	100	176	156	8
		159	30				
		219	40	85	196	156	7
1000	1800	133	30	100	186	136	9
		159	30				
		219	40	85	236	166	8
1150	2000	133	30	145	186	146	10
		159	30				
		219	40	135	236	146	9

For technical reasons in production the discs may be differently spaced in the middle of the idler.

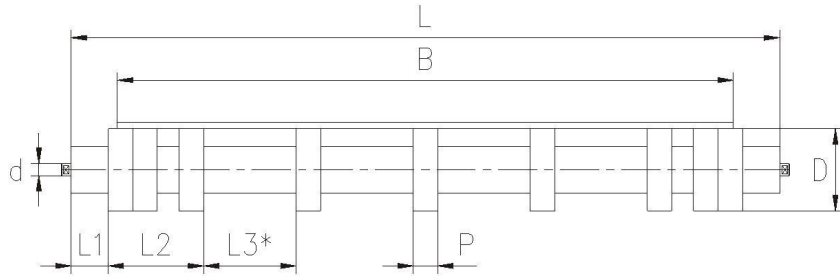

### Return B type idler roller

The support ring forms a tight, flat surface on the outer area of the belt. Designed for medium and heavy belts with long idler spacing.

L	B	D	P	L1	L2	L3	Support ring(pcs)
500	400	108	40	50	100	80	5
		133	40				
		159	40				
600	500	108	40	50	105	125	5
		133	40				
		159	40				
750	650	108	40	50	110	110	6
		133	40				
		159	40				
950	800	108	40	60	155	145	8
		133	40				
		159	40				
		219	50				
1150	1000	108	40	60	155	150	9
		133	40				
		159	40				
		219	50				
1400	1200	108	40	65	195	145	12
		133	40				
		159	40				
		219	50				
1600	1400	133	40	70	195	145	13
		159	40				
		219	50				
1800	1600	133	40	70	200	145	14
		159	40				
		219	50				
2000	1800	133	40	60	200	150	15
		159	40				
		219	50				
2200	2000	133	40	60	200	150	16
		159	40				
		219	50				

For technical reasons in production the discs may be differently spaced in the middle of the idler.



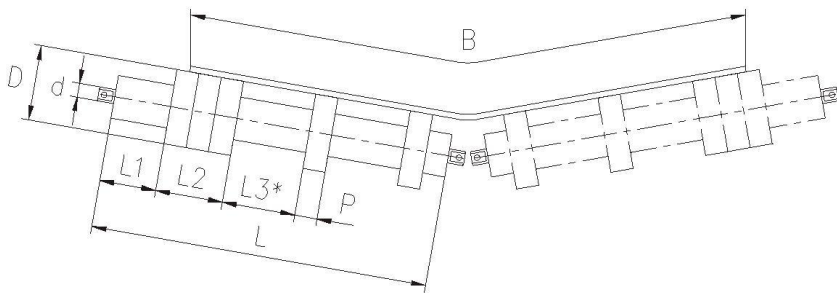

### Return B( II ) type idler roller

For heavy and wide belts. In the common layout, the use of V-shaped or reverse V-shaped support in the lower unloaded section is beneficial to restrain the deviation of the conveyor belt.

L	B	D	P	L1	L2	L3	Support ring(pcs)
380	650	108	40	80	80	126	3
		133	40				
		159	40				
465	800	108	40	70	120	156	4
		133	40				
		159	40				
600	1000	108	40	100	120	136	5
		133	40				
		159	40				
670	1200	108	40	50	160	176	6
		133	40				
		159	40				
		219	50	50	200	146	6
750	1400	133	40	35	160	136	7
		159	40				
		219	50	45	200	186	6
900	1600	133	40	85	160	166	7
		159	40				
		219	50	85	200	146	7
1000	1800	133	40	85	160	186	8
		159	40				
		219	50	85	200	176	7
1150	2000	133	40	135	160	156	9
		159	40				
		219	50	135	200	196	7

For technical reasons in production the discs may be differently spaced in the middle of the idler.

## GARLAND IDLER ROLLER

**SINOCONVE** garland idler roller replace traditional idlers and brackets. The idlers are connected to each other with flexible links and fixed to the conveyor frame with suspension links which allow free movement in the direction of belt travel.

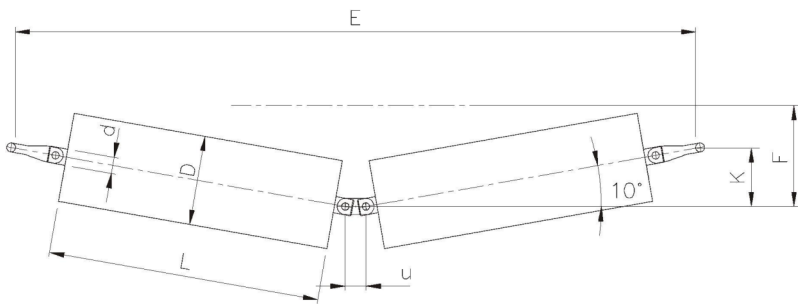

**SINOCONVE** garland idler roller spread the load over more idlers. Thus also the belt profile changes and the belt load becomes steadier. The total quantity of the steel in conveyor frames can often be considerably reduced and the frames simplified.

When conveying heavy items, with the help of garland idlers the pressures against the belt and idlers can be reduced. The life of the belt and idlers increases and thus a better economy is achieved.

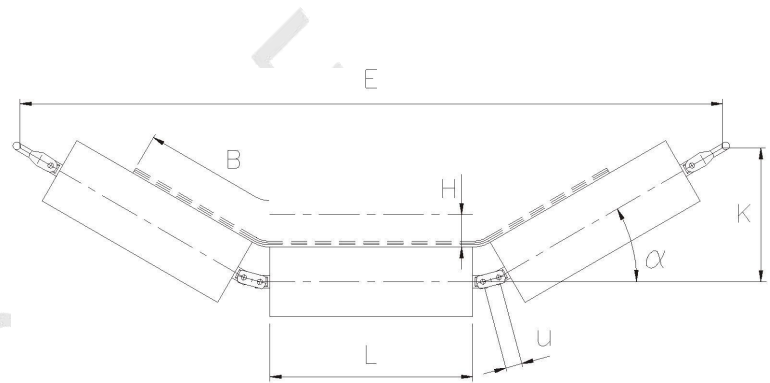

**SINOCONVE** provide four different hanging buckles. By lifting the idler set from the hook, the wreath idler set can be easily replaced.

<b>THREE-PIECE CARRYING GARLAND</b>				
<b>Width Of Conveyor Belt</b>	<b><math>\alpha</math></b>	<b>A</b>	<b>H</b>	<b>D</b>
650-2000	35-45	930-2500	250-730	89-194

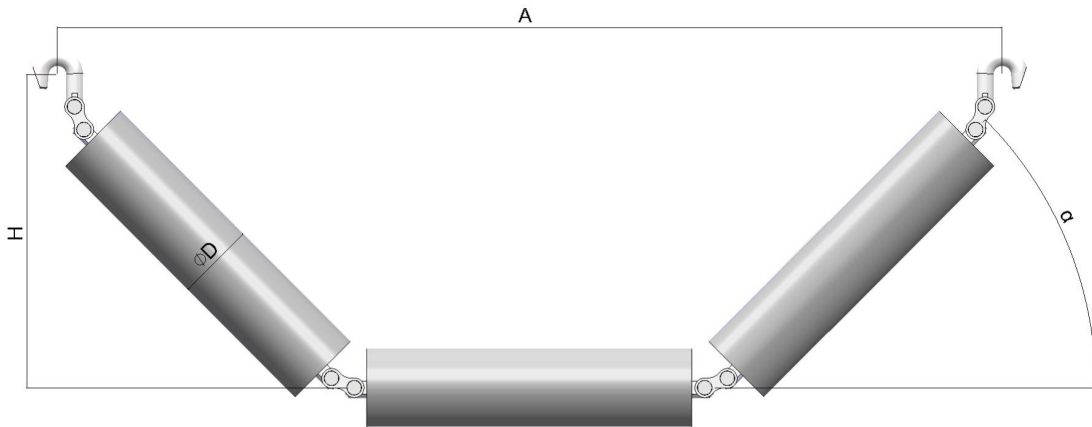

<b>TWO-PIECE CARRYING GARLAND</b>				
<b>Width Of Conveyor Belt</b>	<b><math>\alpha</math></b>	<b>A</b>	<b>H</b>	<b>D</b>
650-2000	10-15	100-2500	90-330	160-219

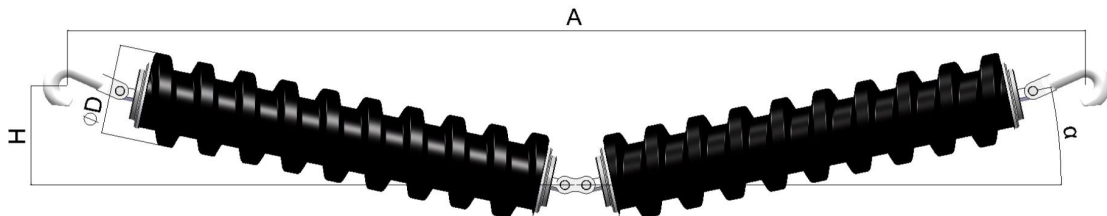

## IDLER ROLLER BRACKET

**SINOCONVE** bracket has a good steel structure, which provides a high load-bearing capacity.



The roller is fixed to the bracket by screws or hanging buckles. When the side idler is tilted forward, the **SINOCONVE** bracket can stabilize the direction of the belt.

The surface of the bracket is processed by hot-dip galvanizing. Hot-dip galvanizing provides good corrosion protection and does not require any special precautions during transportation and handling.



The main bracket is made of sheet metal and can bear the maximum weight. The narrow shape of the top edge of the mechanism effectively prevents the accumulation of cleaning materials.

The wide-bottom brackets of the side supports are connected to the guide rails. Use screw couplings to connect through the guide rails.





<b>Belt Width</b>	500-2000mm
<b>Tube Diameter</b>	Ø89 - Ø159 mm
<b>Tilt Assist</b>	Yes/Yes
<b>Corrosion Protection</b>	Hot-dip galvanized

Further designs on request

<b>Belt Width</b>	400-800mm
<b>Tube Diameter</b>	Ø63.5 - Ø133 mm
<b>Tilt Assist</b>	Yes/Yes
<b>Corrosion Protection</b>	Hot-dip galvanized

Further designs on request

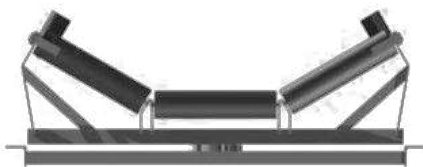
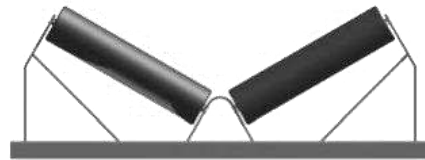

<b>Belt Width</b>	400-800mm
<b>Tube Diameter</b>	Ø63.5 - Ø159 mm
<b>Tilt Assist</b>	No/Yes
<b>Corrosion Protection</b>	Hot-dip galvanized

Further designs on request





<b>Belt Width</b>	400-1600mm
<b>Tube Diameter</b>	Ø63.5 - Ø133 mm
<b>Tilt Assist</b>	No/Yes
<b>Corrosion Protection</b>	Hot-dip galvanized

Further designs on request

<b>Belt Width</b>	400-1600mm
<b>Tube Diameter</b>	Ø63.5 - Ø159 mm
<b>Tilt Assist</b>	No/Yes
<b>Corrosion Protection</b>	Hot-dip galvanized

Further designs on request

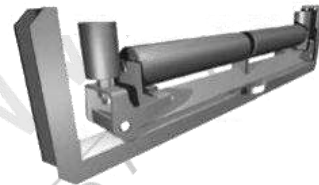



# SINOCCONVE BELT



**PT GLOBAL SINDO PERKASA**

**Whatsapp**

**+62 8128778 6884**

**EMAIL: [gsp.sales@global-sindo.com](mailto:gsp.sales@global-sindo.com)**