

FOTEK

Digital Meter

數位顯示表



CE Rohs

- Economic digital meter / 經濟型數字表
 - Measuring range / 廣泛量測範圍
 - Easy to be mounted / 容易安裝使用
 - Rate of multiple settable / 倍率可設定
 - Zero point settable / 零點可設定
- Voltage : 0 ~ 600V / Current : 0 ~ 20A

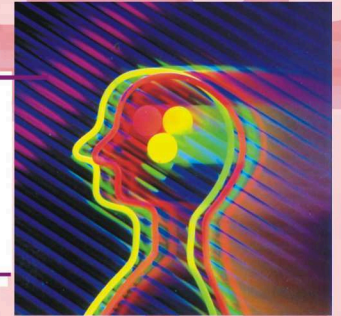

◆ Specification 型號規格【顯示型】 ◆ General data 共同規格

Meter	Outline	Model	Input Range	Display Range
Digital scale meter	DIN 48x24	ARM-14T	0~10VAC or 0~100VAC	- 1999 ~ 9999
		DRM-14T	0~10VDC or 0~100VDC	- 1999 ~ 9999
		DRM-14T-mV	0~100mVDC	- 1999 ~ 9999
		DRM-14T-mA	0~20mA VDC or 4~20mA VDC	- 1999 ~ 9999
		DRM-14T-VR	Variable resistor	- 1999 ~ 9999
	DIN 72x72	ARM-34T	0~10VAC or 0~100VAC	- 1999 ~ 9999
		DRM-34T	0~10VDC or 0~100VDC	- 1999 ~ 9999
		DRM-34T-mV	0~100mVDC	- 1999 ~ 9999
		DRM-34T	0~20mA VDC or 4~20mA VDC	- 1999 ~ 9999
		DRM-34T-VR	Variable resistor	- 1999 ~ 9999
Voltage meter	DIN 48x24	AV-14T	600vac	- 1999 ~ 9999
		DV-14T	600vdc	- 1999 ~ 9999
		DV-14T-mV	1.000vdc	- 1999 ~ 9999
	DIN 72x72	AV-34T	1000vac	- 1999 ~ 9999
		DV-34T	1000vdc	- 1999 ~ 9999
		DV-34T-mV	1.000vdc	- 1999 ~ 9999
Current meter	DIN 48x24	AA-14T	0~5A VAC	- 1999 ~ 9999
		DA-14T	0~5A VDC	- 1999 ~ 9999
		DA-14T-mA	0~200mA VDC	- 1999 ~ 9999
	DIN 72x72	AA-34T	0~20A VAC	- 1999 ~ 9999
		DA-34T	0~20A VDC	- 1999 ~ 9999
		DA-34T-mA	0~200mA VDC	- 1999 ~ 9999

Specification	Data
Power supply	90 ~ 250 Vac 50/60Hz or 24Vdc/ac or 48 Vdc/ac
Control output	Non
Accuracy	±0.1% of F.S.
Response time	200ms
Memory method	EEPROM
Insulation resistance	Over 500MΩ/500Vdc
Dielectric strength	Over 2.5KV/1min.

◆ Connection diagram / 接線圖

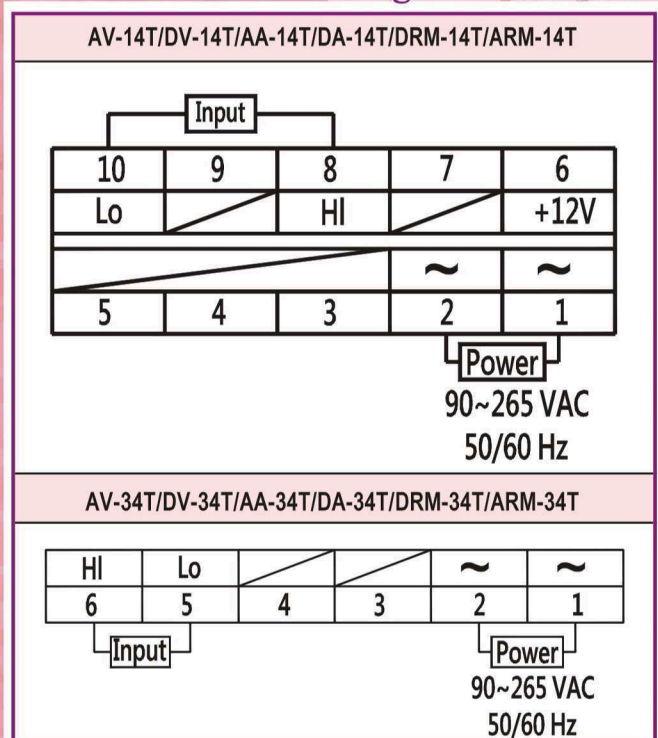

◆ Specification 型號規格【設定型】

Meter	Outline	Model	Input Range	Display Range
Digital scale meter	DIN 48x24	ARM-141	0~10VAC or 0~100VAC	- 1999 ~ 9999
		DRM-141	0~10VDC or 0~100VDC	- 1999 ~ 9999
		DRM-141-mV	0~100mVDC	- 1999 ~ 9999
		DRM-141-mA	0~20mA VDC or 4~20mA VDC	- 1999 ~ 9999
		DRM-141-VR	Variable resistor	- 1999 ~ 9999
	DIN 72x72	ARM-341	0~10VAC or 0~100VAC	- 1999 ~ 9999
		DRM-341	0~10VDC or 0~100VDC	- 1999 ~ 9999
		DRM-341-mV	0~100mVDC	- 1999 ~ 9999
		DRM-341	0~20mA VDC or 4~20mA VDC	- 1999 ~ 9999
		DRM-341-VR	Variable resistor	- 1999 ~ 9999
Voltage meter	DIN 48x24	AV-141	600vac	- 1999 ~ 9999
		DV-141	600vdc	- 1999 ~ 9999
		DV-141-mV	1.000vdc	- 1999 ~ 9999
	DIN 72x72	AV-341	1000vac	- 1999 ~ 9999
		DV-341	1000vdc	- 1999 ~ 9999
		DV-341-mV	1.000vdc	- 1999 ~ 9999
Current meter	DIN 48x24	AA-141	0~5A VAC	- 1999 ~ 9999
		DA-141	0~5A VDC	- 1999 ~ 9999
		DA-141-mA	0~200mA VDC	- 1999 ~ 9999
	DIN 72x72	AA-341	0~20A VAC	- 1999 ~ 9999
		DA-341	0~20A VDC	- 1999 ~ 9999
		DA-341-mA	0~200mA VDC	- 1999 ~ 9999

◆ General data 共同規格

Specification	Data
Power supply	90 ~ 250 Vac 50/60Hz or 24Vdc/ac or 48 Vdc/ac
	4 digits
Control output	Relay 5A/250Vac
Accuracy	±0.1% of F.S.
Response time	200ms
Memory method	EEPROM
Insulation resistance	Over 500MΩ/500Vdc
Dielectric strength	Over 2.5KV/1min.

◆ Connection diagram / 接線圖

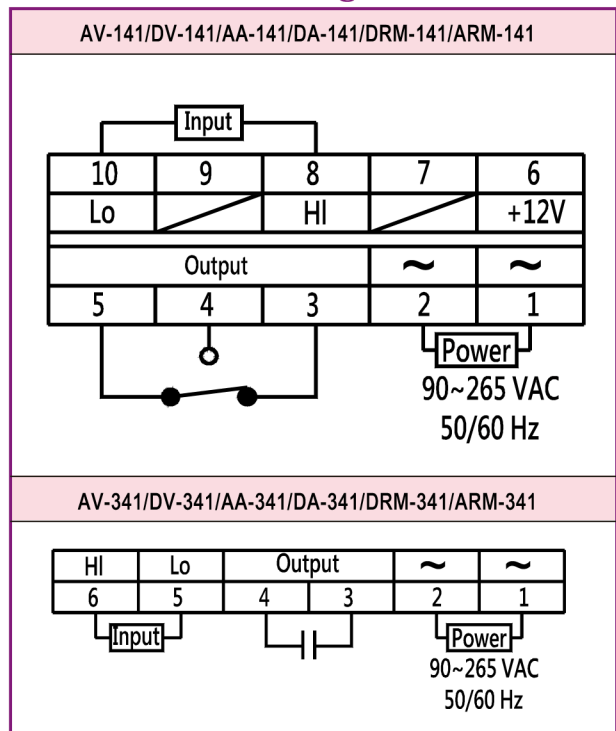

◆ Model guiding / 型號索引

DRM - 141 - 50mV - 100.0 - 24V

1 2 3 4 5

◆ Outline dimension / 外型尺寸

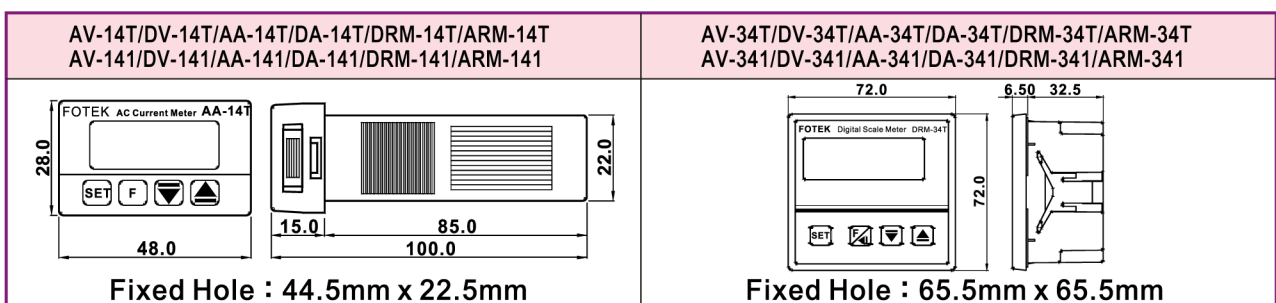

1. Product (表類)
2. Outline (外形)
3. Input (輸入方式)
4. Display (顯示範圍)
5. Power supply (工作電壓)

◆ Setting of parameter / 參數設定【Preset type / 設定型】

Setting conditions	Parameter	Description
運轉狀態 Running state Press SET + □ key ↓ 3 sec	9999	1. Range : - 1999 ~ 9999
鎖定設定 Lock setting Press SET	LK.10	1. 「LK.10」 : All settable 2. 「LK.11」 : Alarm settable
警報模式選擇 Alarm mode Press SET	ALt.0	1. Range : ALt.0 ~ ALt.3
小數點設定 Dp setting Press SET	dP.00	1. Range : 0 ~ 3
低點顯示值設定 Low Value setting Press SET	0	1. Range : -1999 ~ 999 2. 1st digit flashing
高點顯示值設定 High value setting Press SET	1800	1. Range : 0 ~ 9999 2. 4th digit flashing
濾波速度設定 Filter setting Press SET	rL.01	1. Range : 0 ~ 99
動作延遲時間設定 ON delay time setting Press SET	t.0.00	1. Range : 0.00 ~ 9.99S 2. Relay ON delay time
送電延遲時間 Power ON delay time Press SET	dt.05	1. Range : 0 ~ 99S

◆ Alarm setting / 警報值設定 : LK.10

Setting conditions	Parameter	Description
運轉狀態 Running state Press SET key ↓ 3 sec	9999	
警報設定狀態 Alarm setting status Press SET key ↓	SEt.1	1. 「ALt.0」 : PV ≥ SV → Relay ON / LED 1 ON ; PV < (SV-HyS) → Relay OFF / LED 1 OFF
警報值設定 Alarm setting Press SET key ↓	1000	2. 「ALt.1」 : PV ≤ SV → Relay ON / LED 1 ON ; PV > (SV+HyS) → Relay OFF / LED 1 OFF
應差值設定狀態 Hysteresis setting status Press SET key ↓	HYS.1	3. 「ALt.2」 : (SV+HyS) ≥ PV ≥ (SV-HyS) → Relay ON / LED 1 ON
應差值設定 Hysteresis setting Press SET key	1	4. 「ALt.3」 : (SV+HyS) ≥ PV ≥ (SV-HyS) → Relay OFF / LED 1 OFF

◆ Setting of parameter / 參數設定 【Display type / 顯示型】

Setting conditions	Parameter	Description
運轉狀態 Running state Press SET + F key ↓ 3 sec	9999	1 > Range : - 1999 ~ 9999
鎖定設定 Setting of lock Press SET	LK.10	1 > 「LK.10」 : Settable 2 >
小數點設定 Setting of decimal point Press SET	dP.00	1 > Range : 0 ~ 3
低點顯示值設定 Setting of low display Press SET	0	1 > Range : -1999 ~ 999 2 > 1st digit flashing
高點顯示值設定 Setting of high display Press SET	1800	1 > Range : 0 ~ 9999 2 > 4th digit flashing
濾波速度設定 Setting of filter Press SET	rL.01	1 > Range : 0 ~ 99

◆ Zero point setting / 零點設定 : LK.10

Please set **SET** & **▼** key both 「3sec」, the present input value will be transmitted into 「Zero point」, then the PV value is equal to "0". (LK. must to be set to 10)

同時按 **SET** & **▼** 鍵「3秒」, 現在輸入值轉成「零點」顯示值即顯示「0」(LK. 須設成10)

Ex :

Input = (0~10Vdc) , Display vale = (0~ 1000) ; 「Low display」 = 「L.000」 , 「High display」 = 「1000」

When the present input is 5Vdc, If set **SET** & **▼** key both 「3sec」, then Input = (0~10Vdc) → Display value = (-500 ~ 500)

輸入 (0~10Vdc) , 顯示 (0~ 1000) ; 「低點」設「L.000」, 「高點」設「1000」

當輸入「5V」時, 同時按 **SET** & **▼** 鍵「3秒」即可將 (0~10VDC) 轉換成 (-500 ~ 500)

◆ Multiplier setting / 倍率設定 : LK.10

Please set **SET** & **▲** key both 「3sec」, To display the multiplier vale that can be changed by pressing the **F**、**▲** or **▼** key.

* Setting range: 1~9999 * PV = CV * Multiplier value * 「OuEr」 : PV > 9999

同時按 **SET** & **▲** 鍵「3秒」, 顯示倍率設定值【1】個位數閃爍, 按 **F**、**▲** 或 **▼** 可改變設定值

* 倍率設定範圍 : 1 ~ 9999 * PV = CV x 「倍率設定值」 * PV > 9999時顯示「OuEr」

FOTEK CONTROLS CO., LTD.
陽明電機股份有限公司

Copy right @ FOTEK CONTROLS CO., LTD.
2011/1/10

Specification may be modified without
notice in advance.

規格變更恕不事先通知

B-47