

陽

明

電

機

FOTEK

Teaching
FIBER SENSOR
mF Series

Twin adjuster
FIBER SENSOR
V F Series

CE Rohs

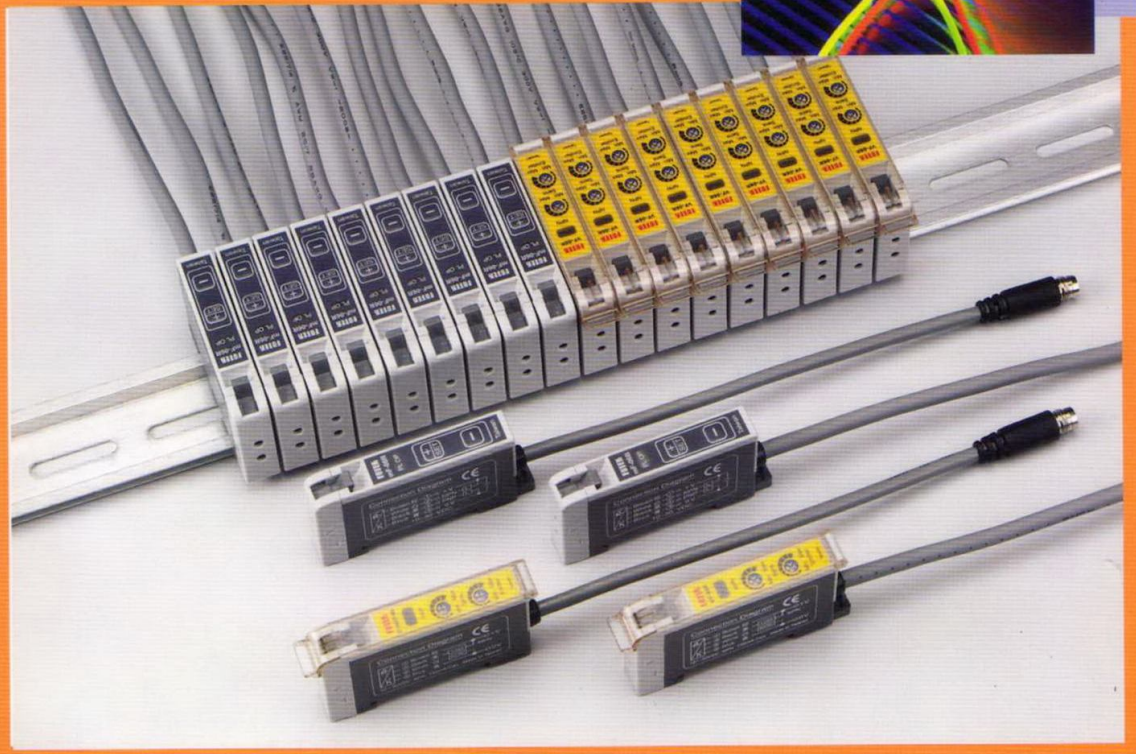
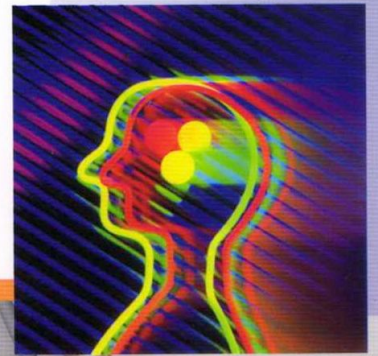

陽明電機股份有限公司
FOTEK CONTROLS CO., LTD.

Easy to finish the optimal detecting condition
By auto-tuning the sensitivity & emitting strength

High speed response time :

ON < 0.1ms / OFF < 0.1ms

Output off delay : 0.1s (Optional)

Dark ON / Light ON is changeable

NPN & PNP two way output



◆ Specification / 規格

Type	型式	Lead wire type 出線式			Lead wire M8 connector type M8 出線接頭式		
Model	型號	mF-01B	mF-06R	mF-06RT	mF-01B-M8	mF-0R-M8	mF-06RT-M8
Emitter	發射光源	Blue LED	Red LED		Blue LED	Red LED	
Output OFF delay	輸出復歸延遲	Non		0.1s	Non		0.1s
Response time	應答時間	200 μs					
Power supply	工作電壓	10 ~ 30VDC ; 45mA max.					
Hysteresis	應差	5% of sensing distance max.					
Output method	輸出方式	NPN & PNP two way output					
Output status	輸出狀態	NO/NC changeable					
Output current	輸出電流	150mA max.					
Residual voltage	殘留電壓	0.1V max.					
Leakage	洩漏電流	0.8mA max.					
Protection circuit	保護電路	Short circuit & Polarity reversed protection					
Housing material	外殼材質	Intensive ABS					
Protection class	保護等級	IP-65					
Circumstance	工作環境	-25°C ~ +60°C ; 35~85% RH					
Connection	出線方式	4c / 5.0Φ x 2m			M8 lead wire connector		

Dimension 外形尺寸

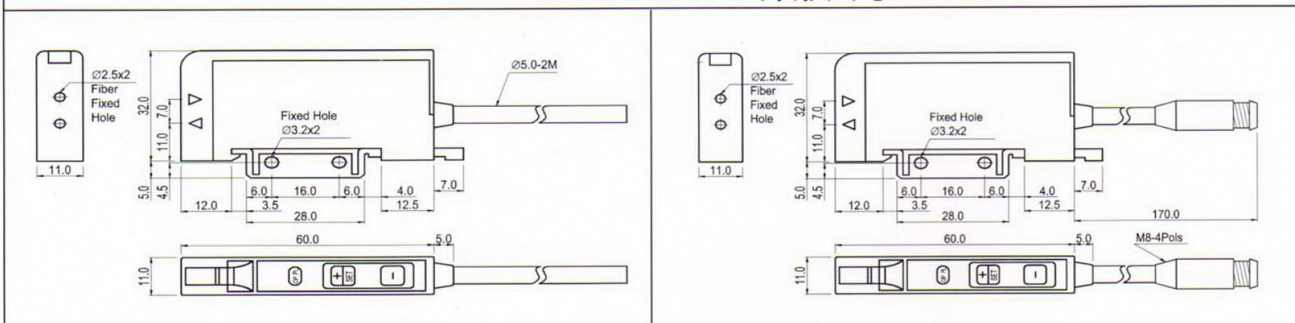

◆ Output circuit & connection diagram / 輸出回路

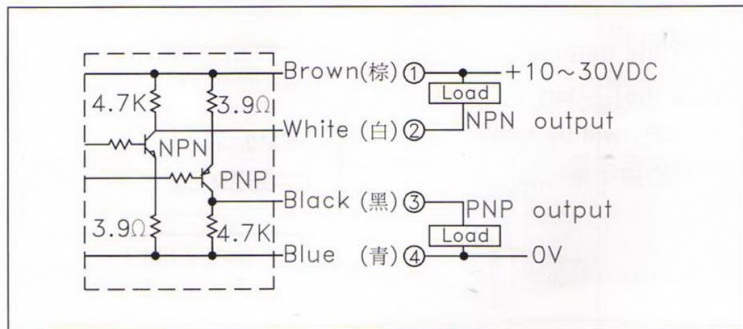

◆ How to change the output status / 如何改變輸出狀態

In the detecting condition, please keep on pressing the $\boxed{+}$ key, then press $\boxed{-}$ key to change the status of output. (If keep on pressing the $\boxed{+}$ key over 3 sec, it may enter to the setting condition)
 如果要改變輸出狀態，請先按住 $\boxed{+}$ 鍵後再按 $\boxed{-}$ 鍵即可改變輸出狀態。
 (注意！不要持續按著 $\boxed{+}$ 鍵超過3秒，否則會進入設定狀態)

◆ How to Set the sensitivity / 如何設定感度【Reflex type / 反射型】

1> Setting of High sensitivity / 高感度設定

Please keep on pressing the $\boxed{+}$ key without the detected object until the LED 「PL」 flicks slowly. Then press the $\boxed{-}$ key again to finish the setting condition. (LED 「PL」 will be turned ON only)
 當無被檢測物時，請按住 $\boxed{+}$ 鍵直到「PL」綠色指示燈慢閃後再按 $\boxed{-}$ 鍵即可完成設定狀態 (只亮「PL」綠色指示燈)

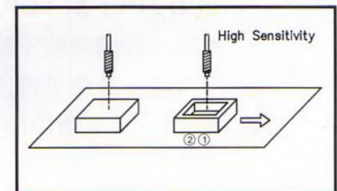

2> Setting of Mid sensitivity / 中感度設定

Please keep on pressing the $\boxed{+}$ key without the detected object until the LED 「PL」 flicks slowly. Then press the $\boxed{+}$ key with the detected object again to finish the setting condition. (LED 「PL」 & 「OP」 will be turned ON)
 當無被檢測物時，請按住 $\boxed{+}$ 鍵直到「PL」綠色指示燈慢閃後，在有被檢測物時再按 $\boxed{+}$ 鍵即可完成設定狀態 (亮起「PL」及「OP」指示燈)

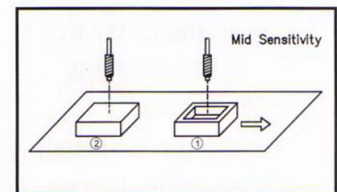



3> Setting of Low sensitivity / 低感度設定

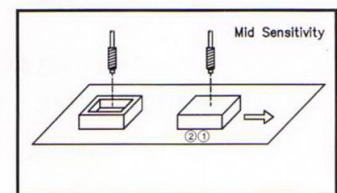

Please keep on pressing the $\boxed{+}$ key with the detected object until the LED 「PL」 flicks slowly. Then press the $\boxed{+}$ key with the detected object again to finish the setting condition. (LED 「PL」 & 「OP」 will be turned ON)
 當有被檢測物時，請按住 $\boxed{+}$ 鍵直到「PL」綠色指示燈慢閃後，在有被檢測物時再按 $\boxed{+}$ 鍵即可完成設定狀態 (亮起「PL」及「OP」指示燈)



◆ How to Set the sensitivity / 如何設定感度【Thru beam type / 透過型】



1> Setting of High sensitivity / 高感度設定

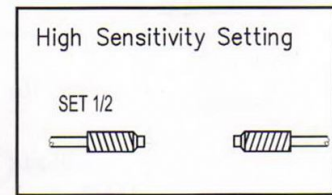

Please keep on pressing the  key without the detected object until the LED 「PL」 flicks slowly. Then press the  key again to finish the setting condition. (LED 「PL」 & 「OP」 will be turned ON)

當無被檢測物時，請按住  鍵直到「PL」綠色指示燈慢閃後再按  鍵即可完成設定狀態（亮起「PL」及「OP」指示燈）





2> Setting of Mid sensitivity / 中感度設定

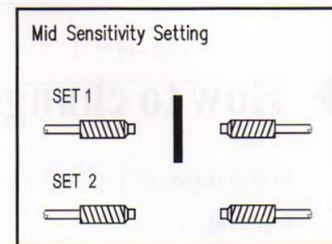

Please keep on pressing the  key with the detected object until the LED 「PL」 flicks slowly. Then press the  key without the detected object again to finish the setting condition. (LED 「PL」 & 「OP」 will be turned ON)

當無被檢測物時，請按住  鍵直到「PL」綠色指示燈慢閃後，在有被檢測物時再按  鍵即可完成設定狀態（亮起「PL」及「OP」指示燈）







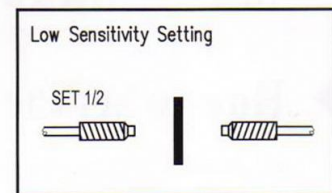

3> Setting of Low sensitivity / 低感度設定

Please keep on pressing the  key with the detected object until the LED 「PL」 flicks slowly. Then press the  key with the detected object again to finish the setting condition. (LED 「PL」 & 「OP」 will be turned ON)

當有被檢測物時，請按住  鍵直到「PL」綠色指示燈慢閃後，在有被檢測物時再按  鍵即可完成設定狀態（只亮「PL」綠色指示燈）



※ Notice / 注意事項

- 1> If the LED 「PL」 flicks fast after finishing setting, it is the maximum sensitivity condition.
如果完成設定後，「PL」綠色指示燈會快閃，表示處於最高感度狀態。
- 2> On the detecting status, if kick to press the  key may increase the sensitivity or press the  key may reduce the sensitivity.
(If keep on pressing the  key over 3 seconds, it will enter to the setting condition)
在檢測狀態，如果點按  鍵可增強感度，如果點按  鍵可減弱感度。
(如果持續按著  鍵超過3秒會進入設定狀態)
- 3> On the detecting status, the LED 「PL」 is the pilot of stability.
在檢測狀態，「PL」綠色指示燈是當穩定燈的功能

◆ How to cut the fiber cable to desired length / 如何裁剪光纖線

Please use the fiber cutter to cut the fiber, please do not use any other tool .

- 1> Insert fiber cable (2.0Φ) to the large hole or insert fiber cable (1.0Φ) to the small hole
- 2> Fast push the fiber cutter to cut the fiber cable.
- 3> Every cutter hole may used once only

請用光纖刀裁剪光纖線，使用其他工具裁剪可能造成感度衰減。

- 1> 將粗光纖線 (2.0Φ) 插入光纖刀大的裁剪孔或將細光纖線 (1.0Φ) 插入光纖刀小的裁剪孔。
- 2> 請快速壓下光纖刀將光纖線裁斷。
- 3> 每個光纖刀裁剪孔限用一次。

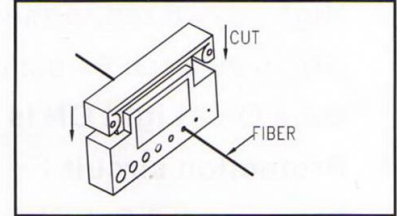

◆ How to use the fiber fixer / 如何使用光纖固定夾具

- 1> It is required to use the fiber fixer to adapt the fiber cable outline is 1.0Φ to the standard outline 2.0Φ
- 2> Insert the fiber cable into the hole of the fiber fixer over 0.5mm after loosening the screw of fiber fixer.
- 3> Tighten the screw of the fiber fixer

1> 1.0Φ 細光纖線須使用光纖固定夾具轉成 2.0Φ 外徑以利固定在放大器上。

- 2> 請鬆開光纖固定夾具的螺帽後，將1.0Φ 細光纖線插入光纖固定夾具（須突出約0.5mm）。
- 3> 鎖緊光纖固定夾具的螺帽。

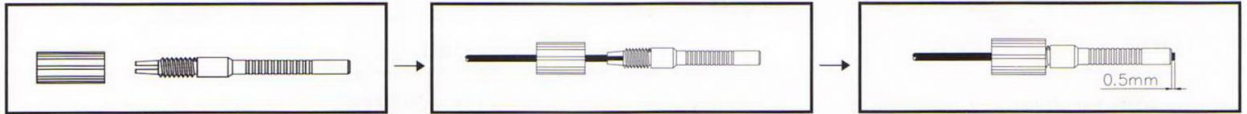

◆ How to fix the fiber cable to the amplifier / 如何安裝光纖線

- 1> Loosing the fixed hook
- 2> Insert the fiber cable into the fixed hole of the amplifier
- 3> Pushing the fixed hook to the fixed position

1> 請鬆開固定勾。

- 2> 將光纖線插入放大器的光纖線固定孔（務須插到底否則感測距離會變短）。
- 3> 扣緊固定勾

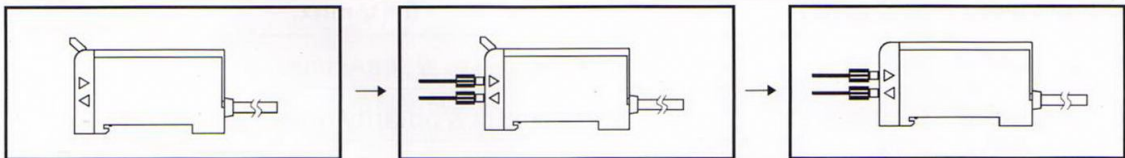

- ❖ **Easy to set optimal detection condition**
by Twin trimmer
- ❖ **High speed response time :**
ON < 0.2ms / OFF < 0.25ms
- ❖ **Dark ON / Light ON is changeable**
- ❖ **Protection circuit :**
Short circuit & Polarity reversed protection

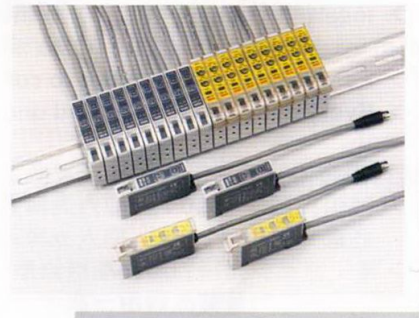

◆ Specification / 規格

Type	型式	Lead wire type 出線式		Lead wire M8 connector type M8 出線接頭式	
Model	型號	VF-06R	VF-06RP	VF-06R-M8	VF-06RP-M8
Output method	輸出方式	NPN	PNP	NPN	PNP
Emitter	發射光源	Red LED			
Operating voltage	工作電壓	10 ~ 30VDC			
Power ripple	電源漣波	20% peak to peak			
Current consumption	耗電流	40mA max.			
Sensing distance	檢測距離	Over 85 mm with FPR-51			
Hysteresis	應差	10 % of sensing distance max.			
Response time	應答時間	ON < 0.2ms ; OFF < 0.25ms.			
Trimmer	調整器	Emitter : Coarse adjuster ; Sens. : fine adjuster			
Output status	輸出狀態	NO / NC changeable			
Output current	輸出電流	150mA max.			
Residual voltage	殘留電壓	0.1V max.			
Leakage current	洩漏電流	0.8mA max.			
Protection circuit	保護電路	Short circuit & polarity reversed protection			
Housing material	外殼材質	Intensive ABS			
Operating circumstance	工作環境	-25°C ~ +80°C ; 35% ~ 85% RH			
Protection class	保護等級	IP-65			

◆ Dimension / 尺寸圖

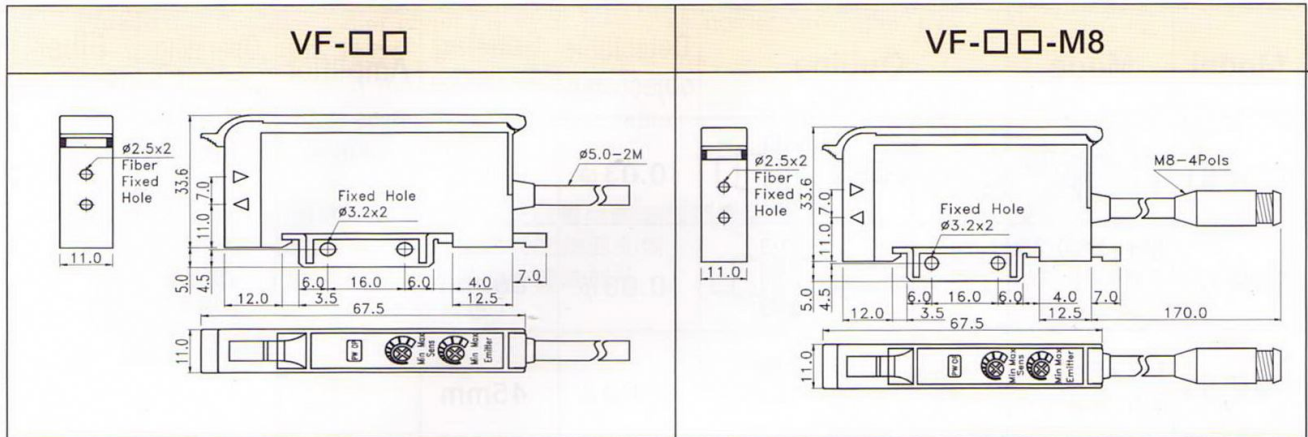

◆ Output circuit & Connection diagram / 輸出回路

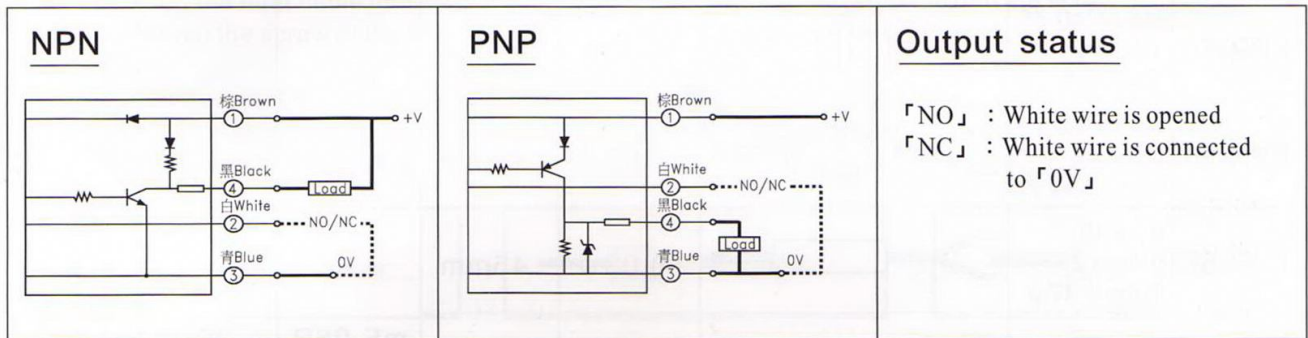

◆ How to adjust the trimmer / 如何調整調整器

- 1> Sens. Adjuster : fine adjuster : To adjust the sensitivity
- 2> Emitter adjuster : Coarse adjuster : To adjuster the strength of emitter (Normally, to be set to Max.)
 - 2-1> 「Reflex type in background condition」 :
Let the 「op」 pilot LED turn ON from OFF status without target by adjusting the 「Emitter adjuster」 , then, Let the 「op」 pilot LED turn OFF by adjusting the 「Sens. Adjuster」 .
 - 2-2> 「Through beam type to detect small object」 :
Let the 「op」 pilot LED turn ON from OFF status without target by adjusting the 「Emitter adjuster」 , then, Let the 「op」 pilot LED turn ON from OFF status by adjusting the 「Sens. Adjuster」

- 1> 接收感度調整器：微調；可調整接收感度
- 2> 發射強度調整器：粗調；一般檢測條件請將發射強度調至"Max."
 - 2-1> 「反射型有背景物時」 先將發射強度調至"Min."再將發射強度調至動作燈"ON"後再調「接收感度調整器」至動作燈"OFF"。
 - 2-2> 「透過型檢測微小物」 先將發射強度調至"min."再將發射強度調至動作燈"ON"後再調「接收感度調整器」至動作燈"OFF"再調至動作燈"ON"後再調大一格。

◆ **Specification / 規格【Reflex type】**

Model	Mode	Outline	Detectable object min.	Sensing distance	Amplifier	Operating temperature	Fiber material
FPR-51	M6 x P=0.75 1.0 φ x 2		0.03 φ	85mm	mF-06R or VF-06R	- 25°C ∩ + 70°C	Poly-plastic
FPR-52	M6 x P=0.75 1.0 φ x 1 0.25 φ x 15		0.03 φ	85mm			
FPR-53	M3 x P=0.5 0.5 φ x 2		0.03 φ	45mm			
FPR-54	M4 x P=0.7 0.5 φ x 2		0.03 φ	45mm			
FPR-55	M6 x P=0.75 1.0 φ x 2 Tube 2.5 φ		0.03 φ	85mm			
FPR-56	M4 x P=0.7 0.5 φ x 2 Tube 1.47 φ		0.03 φ	45mm			
FPR-57	4 φ x 10 0.5 φ x 2 Tube 1.47 φ		0.03 φ	45mm			
FPR-58	3 φ 0.5 φ x 2		0.03 φ	45mm			
FPR-59	M3xP=0.5 0.5 φ x 2 Tube 1.47 φ		0.03 φ	45mm			
FPR-60	4x10x15 1.0 φ x 2 Tube 2.5 φ		0.03 φ	85mm			
FPR-61	3x10x15 0.5 φ x 2 Tube 1.47 φ		0.03 φ	45mm			
FPR-62	4x20x7 1.0 φ x 2		0.03 φ	85mm			
FPR-63	3x13x7 0.5 φ x 2		0.03 φ	45mm			
FPR-64	M6 x P=0.75 1.0 φ x 2		0.03 φ	85mm			
FPR-65	M4 x P=0.7 0.5 φ x 2		0.03 φ	45mm			

◆ Specification / 規格 【Thru beam type】

Model	Mode	Outline	Detectable object min.	Sensing distance	Amplifier	Operating temperature	Fiber material
FPT-01	M4 x P=0.7 0.5Φ x 1		0.06 φ	120mm	mF-06R or VF-06R	- 25°C ∩ + 70°C	Poly-plastic
FPT-02	M4 x P=0.7 1.0Φ x 1		0.1 φ	320mm			
FPT-03	M3 x P=0.5 0.5Φ x 1 Tube 0.9 φ		0.06 φ	120mm			
FPT-04	M4 x P=0.7 1.0Φ x 1 Tube 1.47 φ		0.1 φ	320mm			
FPT-05	M4 x P=0.7 0.5Φ x 1 Tube 1.47 φ		0.06 φ	120mm			
FPT-06	M3 x P=0.5 0.5Φ x 1		0.06 φ	120mm			
FPT-07	3.0Φ x 15 1.0Φ x 1		0.1 φ	320mm			
FPT-08	4Φ x 15.0 0.25Φ x 1		0.03 φ	60mm			
FPT-09	4x10x15 0.5 φ x 1 Tube 0.9 φ		0.06 φ	120mm			
FPT-10	4x10x15 1.0 φ x 1 Tube 1.47 φ		0.1 φ	320mm			
FPT-11	3x10x10 0.5 φ x 1		0.06 φ	120mm			
FPT-12	4x14x14 1.0 φ x 1		0.1 φ	320mm			
FPT-13	3x13x7 0.5 φ x 1		0.06 φ	120mm			
FPT-14	4x15x7 1.0 φ x 1		0.1 φ	320mm			
FPT-15	M4 x P=0.7 1.0 φ x 1		0.1 φ	320mm			

◆ **Dimension / 尺寸圖【Reflex type】**

FPR-51	FPR-52	FPR-53
<p>Technical drawing of FPR-51 showing dimensions: fiber core diameter 1.0X2, M6X0.75 鍍銀黃銅, length 2000.0, 15.0, 3.0, 4.0. Unit: mm.</p>	<p>Technical drawing of FPR-52 showing dimensions: fiber core diameter 1.0, 0.25X15, M6X0.75 鍍銀黃銅, length 2000.0, 15.0, 3.0, 4.0. Unit: mm.</p>	<p>Technical drawing of FPR-53 showing dimensions: fiber core diameter 0.5X2, M3X0.5 鍍銀黃銅, length 2000.0, 18.5, 4.0, 13.5, 1.0. Unit: mm.</p>
FPR-54	FPR-55	FPR-56
<p>Technical drawing of FPR-54 showing dimensions: fiber core diameter 0.5X2, M4X0.7 鍍銀黃銅, length 2000.0, 15.0, 5.0, 2.5. Unit: mm.</p>	<p>Technical drawing of FPR-55 showing dimensions: fiber core diameter 1.0X2, M6X0.75 鍍銀黃銅, length 2000.0, 15.0, 45.0, 2.5. Unit: mm.</p>	<p>Technical drawing of FPR-56 showing dimensions: fiber core diameter 0.5X2, M4X0.7 鍍銀黃銅, length 2000.0, 15.0, 45.0, 1.47, 2.5. Unit: mm.</p>
FPR-57	FPR-58	FPR-59
<p>Technical drawing of FPR-57 showing dimensions: fiber core diameter 0.5X2, length 2000.0, 10.0, 20.0, 1.47, 4.0. Unit: mm.</p>	<p>Technical drawing of FPR-58 showing dimensions: fiber core diameter 0.5X2, length 2000.0, 15.0, 1.0X2, 3.0. Unit: mm.</p>	<p>Technical drawing of FPR-59 showing dimensions: fiber core diameter 0.5X2, M3X0.5 鍍銀黃銅, length 2000.0, 4.0, 13.5, 1.0, 45.0. Unit: mm.</p>
FPR-60	FPR-61	FPR-62
<p>Technical drawing of FPR-60 showing dimensions: fiber core diameter 1.0X2, M2.5 鍍銀黃銅, length 2000.0, 15.0, 45.0, 2.5, 1.0. Unit: mm.</p>	<p>Technical drawing of FPR-61 showing dimensions: fiber core diameter 0.5X2, M1.47 不鏽鋼, length 2000.0, 15.0, 45.0, 3.0, 1.0. Unit: mm.</p>	<p>Technical drawing of FPR-62 showing dimensions: fiber core diameter 1.0X2, M3.2X2, 0.5.7 光點面, length 2000.0, 7.0, 1.5, 3.0, 4.0, 20.0. Unit: mm.</p>
FPR-63	FPR-64	FPR-65
<p>Technical drawing of FPR-63 showing dimensions: fiber core diameter 0.5X2, M2.1X2, 0.3.6 光點面, length 1000.0, 7.0, 0.5, 4.5. Unit: mm.</p>	<p>Technical drawing of FPR-64 showing dimensions: fiber core diameter 0.5X2, M4X0.7 鍍銀黃銅, length 2000.0, 7.0, 3.0, 13.5, 8.1, 7.0. Unit: mm.</p>	<p>Technical drawing of FPR-65 showing dimensions: fiber core diameter 0.5X2, M6X0.75 鍍銀黃銅, length 2000.0, 8.0, 4.8, 15.8, 10.0, 4.0, 11.5. Unit: mm.</p>

◆ Dimension / 尺寸圖 【Thru beam type】

FPT-01	FPT-02	FPT-03
FPT-04	FPT-05	FPT-06
FPT-07	FPT-08	FPT-09
FPT-10	FPT-11	FPT-12
FPT-13	FPT-14	FPT-15

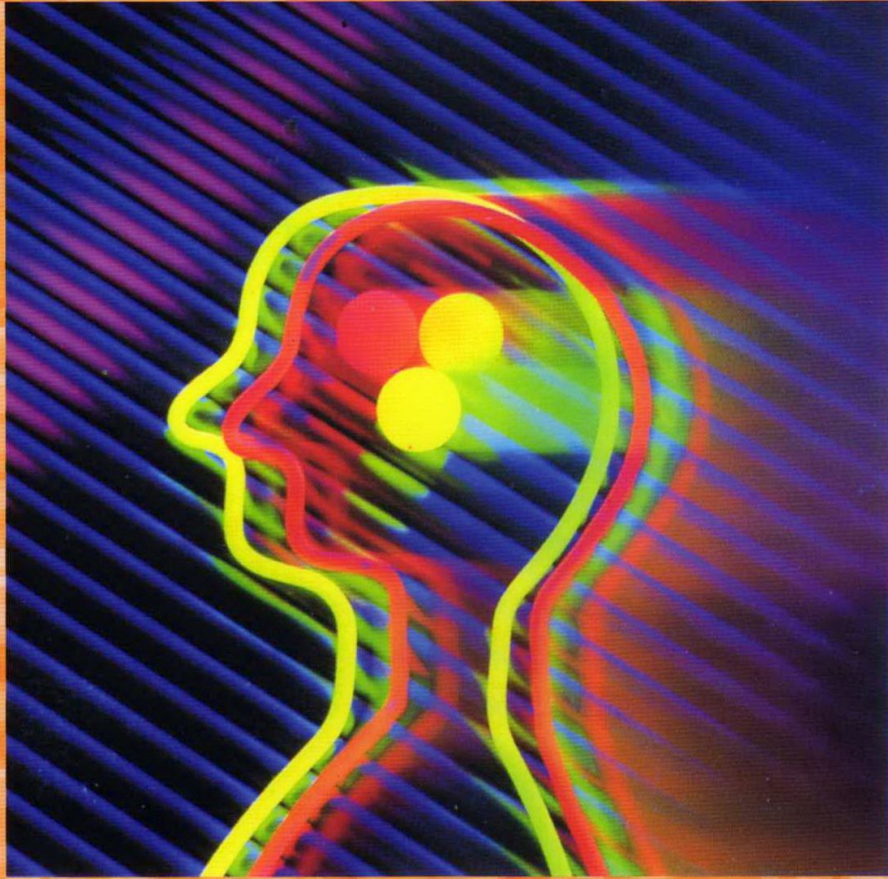

**To manufacture the world standard controls
By mass producing & standardizing
To offer the excellent quality assurance
By advance technology & strictly total quality control**

以『標準化』及『量產化』製造『世界標準』的電控器材。
以『先進技術』及『嚴格品管』提供最佳品質保證。

**陽明電機股份有限公司
FOTEK CONTROLS CO., LTD.**