1: Meeting Commencement

- 1A. Pledge of Allegiance
- 1B. Review and Approval of Agenda

2: Petitions and Communications

- 2A. Proclamation Colin Duffy Day
- 2B. Police Department Presentation
Presentation from Chief Hempelmann regarding the Police Department accomplishments and goals, as well as crime stats and other information.
- 2C. Broomfield Days Presentation
- 2D. 2024R and 2025 Proposed Budget Update

3: Councilmember Reports

4: Public Comment

5: Reports

6: Consent Items

- 6A. Approval of Minutes
Approval of minutes from the August 27 Regular Council Meeting
- 6B. Proposed Resolution for Inmate Food Services
 - Resolution No. 2024-118 Approving Inmate Food Service Contract
- 6C. Proposed Resolution to Replace Existing Police Mobile Radios
 - Resolution 2024-110 Approving the Replacement of Existing Police Mobile Radios
- 6D. Proposed Resolution with North Metro for Temporary Fire Station
 - Resolution No. 2024-95 Approving a Revocable Permit with North Metro Fire Rescue District for a Temporary Fire Station located at the City's Great Western Water Reclamation Facility
- 6E. Proposed Resolution for Detention Center Boiler Replacement
 - Resolution No. 2024-47 Approving an agreement with Design Mechanical Inc. to replace the boiler at the Detention Center
- 6F. Proposed Resolutions for Aggregate Spend Increase for Water Technology and Browns Hill
 - Resolution No. 2024-115 A resolution authorizing and approving an increase in the aggregate spend with Water Technology Group
 - Resolution No. 2024-116 A resolution authorizing and approving an increase in the aggregate spend with Browns Hill Engineering and Controls, LLC
- 6G. Proposed Resolution for ADA Emergency Exit Path
 - Resolution No. 2024-121 Approving a Revocable Permit with Andreea I. Arvinte and Cristian Arvinte for Private Landscaping and Improvements on Outlot A of Broomfield Country Club Filing No. 4
- 6H. Proposed Resolution Authorizing the Assignment of Broomfield Private Activity Bond (PAB) Allocation
 - Resolution No. 2024-128 Authorizing the Assignment of Broomfield's 2024 Private Activity Bond Allocation to the Colorado Housing and Finance Authority

6I. Proposed Resolution No. 2024-138 in Support of the Regional Transportation District's (RTD) 2024 Ballot Initiative Continuing RTD's Exemption from TABOR Cap Limitations

– Resolution No. 2024-138 in Support of the Regional Transportation District's (RTD) 2024 Ballot Initiative Continuing RTD's Exemption from TABOR Cap Limitations

6J. Request for Executive Session Regarding JPPHA

The City and County Attorney is requesting an executive session to discuss the Jefferson Parkway Public Highway Authority to receive legal advice and and obtain instructions to negotiators permitted under C.R.S. § 24-6-402(4)(b) and (e).

6K. Request to Reschedule Executive Session Regarding the City and County Manager's Annual Performance Review

Request for Executive Session per C.R.S. § 24-6-402(4)(f)(l)

7: Action Items

7A. Public Hearing - Ordinance to Implement Contracted Waste Hauling Services - Second Reading and Proposed Resolution Approving an Agreement with Waste Connections for Contracted Waste Hauling

- Ordinance No. 2242 Amending certain sections of Title 8 Chapter 4 of the Broomfield Municipal Code to implement City contracted waste collection services
- Resolution No. 2024-120 Approving an Agreement with Waste Connections of Colorado, Inc. for Broomfield's City-Contracted Residential Waste Collection Services Program

8: Mayor and Councilmember Requests for Future Action

8A. Councilmember Anderson Request for Future Action Regarding Publishing Procedure for Future Ordinances

9: Adjournment

The City and County of Broomfield operates without regard to race, color, national origin, ethnicity, citizenship, immigration status, gender, age, sex, sexual orientation, gender identity, gender expression, marital status, source of income, military status, or disability in all programs and activities.

Individuals with disabilities requiring accommodation or persons needing a language interpreter must submit such a request to the City Clerk no later than noon on Thursday prior to the scheduled Council meeting to allow adequate time to make arrangements. Please call 303.438.6332 or TDD 303.465.5411 or write cityclerk@broomfield.org to make your request.

During the meeting, individuals can click the "CC" button on Live Council meeting video feeds to view closed captioning. Auxiliary hearing aid equipment can be requested on the night of the meeting with our AV team located at the back of the Council Chambers.





Proclamation Colin Duffy Day

Meeting	Agenda Group
Tuesday, September 10, 2024, 6:00 PM	Petitions and Communications Item: 2A
Community Goals	

Overview

[View Correspondence](#)

Mayor Castriotta proclaims September 10, 2024 as Colin Duffy Day.

Attachments

[Memo for Colin Duffy Day Proclamation.pdf](#)

[Proclamation Declaring September 10th as Colin Duffy Day.pdf](#)

Summary

[View Correspondence](#)

Background:

The City and County of Broomfield is proud to recognize and celebrate the outstanding achievements of our local resident, Colin Duffy, who has made significant contributions to the world of sport climbing and bouldering. Colin's dedication, talent, and perseverance have not only brought recognition to himself but have also shone a spotlight on our community, inspiring young athletes and citizens alike.

Colin Duffy, who burst onto the international competitive circuit in September 2017, has quickly risen to become one of the most prominent figures in sport climbing. His accomplishments are numerous and include:

Medaling in four World Cups.

Competing as a two-time Olympian, finishing 7th in the 2020 Tokyo Olympics, and finishing 4th in Bouldering and Lead Combined and 7th in Combined in the 2024 Paris Olympics.

At age 16, becoming the youngest climber to qualify for the 2020 Summer Olympic Games in Tokyo and the second American climber to do so.

Winning both Boulder and Lead disciplines at the IFSC World Cup in Innsbruck on June 26, making him the first male athlete to achieve this feat in a single World Cup event.

Claiming his first youth title at the age of nine, followed by ten national youth titles and two world youth titles.

Colin's achievements are a testament to his hard work and determination, and they serve as an inspiration to athletes and aspiring climbers in our community and beyond.

Financial Considerations

N/A

Prior Council or Other Entity Actions

N/A

Boards and Commissions Prior Actions and Recommendations

N/A

Proposed Actions / Recommendations

N/A

Alternatives

N/A



Proclamation

PROCLAMATION DECLARING SEPTEMBER 10, 2024 AS COLIN DUFFY DAY

- WHEREAS, *Colin Duffy burst onto the world's competitive climbing circuit in September of 2017, showcasing his exceptional talent and dedication to the sport of climbing; and*
- WHEREAS, *Colin Duffy, at the age of nine, claimed his first youth title and has since won ten national youth titles and two world youth titles, demonstrating his long-standing commitment and excellence in climbing; and*
- WHEREAS, *at age 16, Colin Duffy became the youngest climber to qualify for the 2020 summer Olympic Games in Tokyo, Japan, and the second American climber to do so, after winning the 2020 International Federation of Sport (IFSC) Pan American Championships in March 2020; and*
- WHEREAS, *Colin Duffy made history on June 26, 2021 at the IFSC World Cup in Innsbruck by becoming the first male athlete to win both Boulder and Lead at the same World Cup event; and*
- WHEREAS, *Colin Duffy is a two-time Olympic athlete, having competed in the 2020 Tokyo Olympics, where he secured a 7th-place finish, and competed in the 2024 Paris Olympics, placing 4th in Bouldering and Lead Combined and 7th in Combined, further solidifying his status as a world-class athlete; and*
- WHEREAS, *Colin Duffy has become an inspiration to many, embodying the spirit of perseverance, determination, and athletic excellence.*

NOW, THEREFORE, I, *Guyleen Castriotta, Mayor of the City and County of Broomfield, do hereby declare and proclaim September 10, 2024 as:*

COLIN DUFFY DAY

In witness whereof, I hereunto set my hand and official seal on this the 10th day of September 2024.

Guyleen Castriotta
Mayor



Broomfield Days Presentation

Meeting	Agenda Group
Tuesday, September 10, 2024, 6:00 PM	Petitions and Communications Item: 2C
Presented By	
Matthew Gulley	
Community Goals	
<input checked="" type="checkbox"/> Thriving, Diverse, Safe and Welcoming Community	

Overview

[View Correspondence](#)

The Broomfield Days festivities now span two weekends. Saturday September 14th is the Broomfield Days Senior Resource Board (SRB) Golf Tournament at Eagle Trace Golf Club. The following weekend on Friday September 20th there will be Bingo In the Park, hosted by the Broomfield Crossing Rotary Club, at 7 pm. Saturday September 21st is when the main event occurs at Midway Park, beginning at 7 am. The event includes the Pancake Breakfast hosted by the Broomfield Crossing Rotary Club, the Mayor's Cup 5K and Fun Run, community parade, food trucks, beer gardens hosted by the Broomfield Chamber of Commerce, family friendly activities, three stages of performances, the DockDog competition, the Senior Resources Board Car Show, and close to 300 vendors booths. The event finishes up Saturday night with more Bingo In the Park at the Girl Scout Shelter.

Attachments

[Memo for Broomfield Days.pdf](#)

[2024 Broomfield Days map \(draft\).pdf](#)

Summary

[View Correspondence](#)

The 2024 Broomfield Days community event will be held on Friday, September 20, and Saturday 21, 2024 at Midway Park.

The festival kicks off early on Saturday, September 14th with the Broomfield Days Open Golf Tournament at Eagle Trace Golf Course at 8 a.m. This event supports senior programs through the Senior Resources of Broomfield, Inc., and Senior Resources of Broomfield is the presenting sponsor this year.

On Friday, September 20 the bingo games hosted by the Rotary Club of Broomfield Crossing will begin at 7 p.m. at the Girl Scout Shelter at Midway Park.

Saturday begins with the ever-popular Pancake Breakfast hosted by the Rotary Club of Broomfield Crossing from 7 to 10 a.m. at the Girl Scout Shelter. The cost for breakfast is \$12 for those 13 years and older, \$6 for those 6 to 12 years old, and 5 and under are free.

Broomfield Days is packed with activities for the whole family including the Mayor's Cup 5K Race and 1-mile Fun Run, Broomfield Optimist Clown Contest, Broomfield Community Parade, Broomfield Chamber of Commerce Trade Fair, arts and crafts festival, food booths, three stages of entertainment and demonstrations, Bow Wow Broomfield featuring the Rocky Mountain Dock Dogs competition, and great community spirit.

Publicity for Broomfield Days is managed by the Community Engagement team.

Financial Considerations

As shown in the sources and uses of funds summary below, the project can be completed within the budgeted amount.

Sources and Uses of Funds	Amount
04-66440 2024 Operating Budget (Special Events) Project Code: BFDAYS	\$42,500
Contractual Services	
	-\$37,500
Supplies Operating - Consumables	
	-\$5,000
Projected Balance	\$0

Prior Council or Other Entity Actions

N/A

Boards and Commissions Prior Actions and Recommendations

N/A

Proposed Actions / Recommendations

N/A

Alternatives

N/A



2024 BROOMFIELD DAYS



PLEASE NOTE: MAP IS NOT TO SCALE.



LEGEND

-  TICKET BOOTH
-  ENTERTAINMENT STAGE
-  DIAPER CHANGING STATION
-  INFORMATION BOOTH
-  FIRST AID
-  BROOMFIELD 100 DROP-OFF
-  BRIDGE
-  PORT-A-POTTIES
*ACCESSIBLE STALLS
-  GREEN ZONE STATIONS
-  ATM MACHINES
-  ACCESSIBILITY SHUTTLE STOP
-  ROAD CLOSED



City of Broomfield

City Council Regular Meeting

Approval of Minutes

Approval of minutes from the August 27 Regular Council Meeting

Meeting	Agenda Group
Tuesday, September 10, 2024, 6:00 PM	Consent Items Item: 6A
Community Goals	

Summary

Approval of Minutes for Regular Council Meeting of MONTH DAY, YEAR.

Attachments

[Minutes of August 27, 2024.pdf](#)

Minutes for the City Council Regular Meeting

One DesCombes Drive, Broomfield, CO 80020

August 27, 2024, 6:00 PM - August 27, 2024, 9:15 PM

The Mayor called for a short break at 8:00 pm. The meeting reconvened at 8:10 pm.

Roll Call: *(The following members were in attendance)*

- **Guyleen Castriotta**, Mayor
- **Laurie Anderson**, Ward 4
- **Todd Cohen**, Ward 5
- **Paloma Delgadillo**, Ward 2
- **Heidi Henkel**, Ward 5
- **Bruce Leslie**, Ward 4
- **Jean Lim**, Ward 3
- **James Marsh-Holschen**, Ward 1
- **Kenny Van Nguyen**, Ward 1
- **Deven Shaff**, Mayor Pro Tem, Ward 3
- **Austin Ward**, Ward 2

Also Present:

- Anna Bertanzetti, Interim Deputy City and County Manager
- Nancy Rodgers, City and County Attorney
- Michelle Parker, Deputy City and County Clerk
- And various staff members

1. Meeting Commencement

1A. Pledge of Allegiance- 6:02 PM

1B. Review and Approval of Agenda- 6:02 PM

2. Petitions and Communications

2A. Proclamation Declaring September 2024 as Workforce Development Month- 6:03 PM

2B. Proclamation Declaring August 31, 2024 as International Overdose Awareness Day - 6:12 PM

3. Councilmember Reports

4. Public Comment

5. Reports

5A. Performance and Internal Audit Semi-Annual Update- 6:37 PM

5B. Event Center Demolition Approach- 6:49 PM

6. Consent Items

Councilmember Ward moved to approve the Consent Items 6A - 6E, seconded by Mayor Pro Tem Shaff. The motion passed 10-0.

6A. Approval of Minutes- 7:30 PM

6B. Board of Equalization Approval of Abatement Petition Administrative Denials- 7:30 PM

6C. Board of Equalization Approval of Corrected Mutual Agreement for Abatement- 7:30 PM

6D. Proposed Resolution approving an Amended and Restated Intergovernmental Agreement Concerning the Boulder-Broomfield Regional HOME Consortium- 7:30 PM

6E. Proposed Resolution approving an IGA with RTD for Election Services- 7:30 PM

7. Action Items

7A. Rezoning GDC City and County and Police Buildings Ordinance 1st Reading- 7:35 PM

Councilmember Ward moved to approve Ordinance No. 2249 on first reading and order published by title, seconded by Councilmember Marsh-Holschen. The motion passed 10-0.

7B. Proposed Resolution Approval of the Raptor Plan- 7:40 PM

Councilmember Leslie moved to approve Resolution No. 2024-101 Approving the 2024 Raptor Management Plan, seconded by Councilmember Henkel. The motion passed 10-0.

7C. Proposed Resolution Withdrawal from the Rocky Flats Stewardship Council - 8:31 PM

Mayor Pro Tem Shaff moved to approve Resolution No. 2024-119 Issuing a Notice of Intent to Withdraw from the Rocky Flats Stewardship Council, seconded by Councilmember Ward.

Councilmember Henkel moved to introduce an amendment to the motion, seconded by Councilmember Marsh-Holschen. The motion to introduce passed 8-2, with Councilmember Leslie

and Mayor Pro Tem voting no. The proposed amendment failed by a vote of 4-6, with Mayor Pro Tem Shaff and Councilmembers Ward, Leslie, Delgadillo, Lim, and Anderson voting no.

The original motion to approve Resolution No. 2024-119 passed 8-2 with Councilmembers Henkel and Marsh-Holschen voting no.

8. Mayor and Councilmember Requests for Future Action

9. Adjournment



City of Broomfield

City Council Regular Meeting

Proposed Resolution for Inmate Food Services

Meeting	Agenda Group
Tuesday, September 10, 2024, 6:00 PM	Consent Items Item: 6B
Presented By	
Enea Hempelmann, Chief of Police	
Community Goals	
<input checked="" type="checkbox"/> Thriving, Diverse, Safe and Welcoming Community	

Overview

[View Correspondence](#)

Broomfield is required to provide food services to inmates housed at the Broomfield Detention Center. The agreement with Summit Food Service (Summit), the current food services vendor, expires October 31, 2024.

Attachments

[Council Memo for Inmate Food Services at Detention Center.pdf](#)

[Resolution 2024-118 Approving Inmate Food Service Contract.pdf](#)

[Broomfield_Agreement for Inmate Food and Commissary Services-Trinity Services Group Inc_.pdf](#)

Summary

[View Correspondence](#)

Broomfield is required to provide food services to inmates housed at the Broomfield Detention Center. The agreement with Summit Food Service (Summit), the current food services vendor, expires October 31, 2024.

On June 12, 2024, Broomfield's Procurement Manager published an invitation for Bid 24-RFP-PA-001 for inmate food services, which includes inmate meals, employee meals, inmate commissary, and an inmate trust accounting system. Vendors were required to submit a complete response package including references, scope and specifications, service pricing template, and transition plan by July 2, 2024. Four vendors responded: Healthcare Services Group, Summit Food Services, Trinity Services Group, and TW Vending. Summit is the current food service provider and has been since 2007.

Bids were as follows based on the daily population of the detention center, for per meal inmate costs for between 80 to 89 inmates: \$6.86- Healthcare, \$3.41- Summit, \$3.99- Trinity, \$4.41- TW (TW did not include hot meals). Each proposed vendor also provided a commissary plan in which the inmates can purchase upgraded hygiene supplies, candy, and comfort food. The Detention Center receives a percentage of all commissary sales, which is deposited into the Inmate Welfare account and used to pay costs associated with the educational, recreational, and program supplies for inmates. Healthcare Services Group proposed a commissary commission rate of 25%, Summit 27%, Trinity 27%, and TW Vending 30%. After review of the proposals, Trinity and Summit were chosen to provide further information and a presentation.

Meal variety, quality, and quantity is a key for the safety and security of inmates and officers. This topic was addressed by the Colorado Jail Standards Commission in the introduction of the Colorado Jail Standards pursuant to HB22-1063. The food service vendor must provide five types of special meals, including medical, food-allergy, vegetarian, pregnancy/postpartum, and religious diets.

The food service provider also provides the inmate accounting system, an important element to track bonds, medical billing, and commissary purchases. The Detention Center currently uses the Lockdown accounting system which Trinity will continue to provide until/if it is determined that a change is needed.

Staff believes the contracting of food services, commissary services, and inmate accounting system with Trinity Services Group to be the most cost effective, reliable, safe and secure for the inmates and officers at the Detention Center.

Resolution No. 2024-118 approves the proposed agreement with Trinity Services Group for the Detention Center's food, commissary, and inmate trust accounting services. If approved, Trinity Services Group would provide services under the new contract, effective November 1, 2024.

Financial Considerations

As shown in the sources and uses of funds summary below, the project can be completed within the budgeted amount.

Sources and Uses of Funds	Amount
Fund 1 02-23300-53170 Proposed 2025 budget for inmate food	\$287,000
Fund 2 02-23300-53450 Proposed 2025 budget for employee food	\$22,680
Mid Year Supplemental Request 2025	\$172,048
Inmate Meals	
	-\$427,728
Officer Meals	
	-\$54,000
Projected Balance	\$0

Prior Council or Other Entity Actions

Council has approved food services contracts in the past. The most recent contract was approved by [Resolution 2020-156](#), on July 7, 2020.

Boards and Commissions Prior Actions and Recommendations

N/A

Proposed Actions / Recommendations

If Council desires to approve the contract, the appropriate motion is...
That Resolution 2024-118 be adopted.

Alternatives

Reject the contract and provide alternative direction to staff. An agreement must be in place by October 31, 2024.

RESOLUTION NO. 2024-118

A resolution approving an Agreement with Trinity Services Group, Inc. for Inmate Food Services and Commissary Services

Section 1.

The agreement between the City and County of Broomfield and Trinity Services Group, Inc. in an amount not to exceed \$482,000 for inmate food services is hereby approved.

Section 2.

The Mayor or Mayor Pro Tem is authorized to sign and the Office of the City and County Clerk to attest to an agreement, in form approved by the City and County Attorney.

Section 3.

The City and County Manager or a designee is authorized to renew the agreement for three additional one-year periods, subject to annual budget appropriation.

Section 4.

The City and County Manager or a designee is authorized to approve change orders annually in aggregate amounts up to ten percent of the then current contract amount.

Section 5.

The resolution is effective on the date of approval by the City Council.

Approved on September 10, 2024.

The City and County of Broomfield, Colorado

Mayor

Attest:

Office of the City and County Clerk

Approved as to form:

KKH

City and County Attorney

AN AGREEMENT BY AND BETWEEN THE CITY AND COUNTY OF BROOMFIELD
AND TRINITY SERVICES GROUP, INC. FOR INMATE FOOD AND COMMISSARY SERVICES

1. PARTIES. The parties to this Agreement for Inmate Food and Commissary Services (this “Agreement”) are the City and County of Broomfield, a Colorado municipal corporation and county, (the “City”) and Trinity Services Group, Inc., a Florida corporation (the “Contractor”), collectively, the “Parties,” or individually, a “Party.”
2. RECITALS. The Recitals to this Agreement are incorporated herein by this reference as though fully set forth within the body of this Agreement.
 - 2.1. The City is seeking to purchase inmate food services, commissary delivery and management services, and inmate trust accounting as it relates to services at the Broomfield Detention Center located at 11600 Ridge Pkwy, Broomfield, CO 80021 and completed a competitive selection process by Request for Proposal # 24-RFP-PA-001.
 - 2.2. The Contractor’s response to the above referenced RFP was determined to be of best value to the City for the procurement of the services requested.
 - 2.3. The Parties therefore desire to enter into an Agreement for completion of the services further described herein.
3. TERMS AND CONDITIONS. In consideration of the mutual covenants and promises of the Parties contained herein, and other valuable consideration, the receipt and adequacy of which are hereby acknowledged, the Parties agree as follows:
 - 3.1. Term. The Term of this Agreement shall commence September 11, 2024, with full services upon transition beginning on or before November 1, 2024, and extend and be effective through October 31, 2025. This Agreement may be renewed for three successive one-year terms upon the same terms and conditions by written amendment executed by both Parties. Such renewal shall be a prerogative of the City and not a right of the Contractor and is subject to annual budget and appropriation determinations by the City.
 - 3.2. Scope. The Contractor shall furnish the labor, equipment, materials and supervision necessary for or incidental to the complete and timely performance of everything described or reasonably implied from the Scope of Work attached hereto as Exhibit A and incorporated by this reference.
 - 3.3. Price. The City shall pay the Contractor for goods and services set forth in the Scope of Work in accordance with the amount or amounts shown in the Pricing

Schedules attached as Exhibit B and incorporated by this reference. Total payments under this Agreement shall not exceed \$482,000.

- 3.3.1. *Renewal Term Pricing.* Upon expiration of the original term, the Parties may enter into amendment to extend the term of the Agreement as set forth in Section 3.1 above. Pricing adjustments by the Contractor for any extended term shall not exceed 3% or the current increase in the Denver-Aurora-Lakewood Consumer Price Index - Food Away from Home using the most recently posted twelve-month period at the time of mutually agreed upon term extension, whichever is greater. The City will notify the Contractor of the desire to extend the Agreement approximately 60 days prior to the end of the term to allow the Parties time to mutually agree upon the contract amendment to extend the renewal term and the pricing as set forth in this paragraph.
- 3.3.2. *Material Cost Changes.* In addition to updating prices annually as set forth in Section 3.3.1 above, the Contractor may submit a request to the City to increase pricing due to material changes in costs due to changes beyond the Contractor's control. The Contractor and the City shall negotiate in good faith to adjust pricing to address price increases (or decreases) that are the result of changes beyond the Contractor's reasonable control including, changed in federal, state or local laws relating to taxation or minimum wage (i.e. prevailing wages) and similar changes in the laws, materials changes in supply costs, or other changes in circumstances beyond the Contractor's control. The Parties will memorialize any agreement through a contract amendment.
- 3.4. Payment. The Contractor will timely issue invoices for products and/or services delivered or rendered pursuant to this Agreement. Unless a different payment schedule is specified in this Agreement, timely issuance of invoices is considered by the tenth (10th) day of each month after the completion of the Services. Invoices for such Services shall include (a) date on which Services were provided, (b) the location for which the Services were provided, (c) details of Services delivered, (d) and purchase order number. Invoices shall be paid within thirty (30) days of approval by the City representative. Failure to submit invoices for timely payment may result in nonpayment. The City will notify the Contractor of any dispute with respect to an invoice in writing. Both Parties will use best efforts to resolve any dispute within 180 days. Incorrect payments to the Contractor due to omission, error, fraud, or defalcation may be recovered from the Contractor by deduction for subsequent payments due to the Contractor under this Agreement or other contracts between the City and the Contractor.

- 3.5. Audit Rights. The Contractor will permit the authorized agents and employees of the City at reasonable hours, to inspect, review, and audit all records of the Contractor related to this Agreement and the work to be performed hereunder. The Contractor, its employees, subcontractors, and agents shall maintain all books, documents, papers, and accounting records related hereto, and all information regarding costs incurred herein, at their offices during the contract period and for three years thereafter.
4. NOTICE AND AUTHORIZED REPRESENTATIVES. Any notice required or permitted by this Agreement shall be in writing and shall be sufficiently given for all purposes if sent by email to the authorized representative identified below. Such notice shall be deemed to have been given when the email was sent and received. The City may change its representative at any time by notice to the Contractor. The Contractor shall not replace the Contractor Representative unless: (a) the City requests a replacement, or (b) the Contractor terminates the employment of the Contractor Representative and provides a satisfactory substitute. The City must approve a substitute Contractor Representative, and, if no substitute is acceptable, the City may terminate this Agreement. The Parties each designate an authorized representative as follows:
- 4.1. The City designates the Commander in charge of the Detention and Training Center, currently Dave Walts, as the authorized representative of the City under this Agreement. Email address is dwalts@broomfield.org.
- 4.2. The Contractor designates Ron Torres as the authorized representative of the Contractor under this Agreement. Email address is Ronald.torres@trinityservicesgroup.com.
- If the Contractor is alleging that the City is in breach of this Agreement or has violated any term of this Agreement, Legal Notice shall be made by making the notice above with a copy to citycountyattorney@broomfield.org.
5. INDEPENDENT CONTRACTOR. The Contractor is an independent contractor as provided in C.R.S. § 8-40-202(2). The Contractor is not entitled to workers' compensation benefits and the Contractor is obligated to pay federal and state income tax on monies earned pursuant to this Agreement.
6. INDEMNIFICATION. The Contractor expressly agrees to indemnify, defend and hold harmless the City or any of its officers or employees, agents, or officials from any and all claims, damages, liability, or court awards, including costs and attorney's fees, that are or may be awarded as a result of any loss, injury, or damage sustained or claimed to have been sustained by anyone, including but not limited to, any person, firm, partnership, or corporation, in connection with or arising out of any act, omission or act of commission by Contractor or any of its employees or agents in performing work

pursuant to this Agreement. In the event that any such suit or action is brought against the City, the City will give timely notice thereof to the Contractor.

7. INSURANCE. To assure the City that the Contractor is always capable of fulfilling specified indemnification obligations, the Contractor shall purchase and maintain insurance of the kind and in the amounts required by the City, from an insurer with an AM Best FSR rating of A- or higher as more particularly set forth on Exhibit C. Current proof of such insurance is attached at Exhibit C, incorporated by this reference. However, proof of insurance attached as Exhibit C shall not be deemed to limit or define obligations of Contractor as provided elsewhere in this Agreement, and Contractor should rely on its expertise to obtain additional insurance coverage needed for the City and Contractor in its performance hereunder.
8. DEFAULT. If the Contractor fails to comply with any provision of this Agreement, the Contractor shall be liable for any and all damages, including without limitation, the cost of procuring similar supplies and services and all other costs and expenses incurred by the City because of such failure. If the Contractor fails or refuses to perform the work on schedule, or to complete the work in a timely and satisfactory manner, the City may terminate this Agreement and the Contractor's right to proceed hereunder. If the City terminates this Agreement under this paragraph, the Contractor may, at the option of the City, be required to cease any or all work provided for under this Agreement and shall be liable for any additional cost to the City for services acceptable to the City from another contractor as well as any actual damages associated with such failure to perform.
9. APPROVAL OF SUBCONTRACTORS AND CONSULTANTS. The City acknowledges and agrees that Keefe Commissary Network will be providing the commissary services under this Agreement, and the City hereby consents to Keefe Commissary Network as a subcontractor. The Contractor shall not employ any subcontractors or consultants without the prior written approval of the City Representative. Prior to commencing any work, each subcontractor or consultant shall provide the appropriate insurance as required for the Contractor under this Agreement. The Contractor shall be responsible for coordination of the work and the acts and omissions of its agents, employees, subcontractors, consultants and suppliers, and shall bind each to the terms of this Agreement so far as are applicable. This Agreement is voidable by the City if subcontracted by the Contractor without the express written consent of the City.
10. PROTECTION OF PROPERTY. All City property, including but not limited to, existing structures, utilities, services, roads, trees, shrubbery, walls, or flooring, shall be protected against damage or interrupted services at all times by the Contractor while performing services pursuant to this Agreement. The Contractor shall be held responsible for repairing or replacing any and all property that is damaged by reason

of the Contractor's work to the satisfaction of the City within three (3) weeks of the notification of such damage, which may be extended with written approval of the City.

11. NO THIRD PARTY BENEFICIARIES. This Agreement is intended to describe the rights and responsibilities only as to the parties hereto. This Agreement is not intended and shall not be deemed to confer any rights on any person or entity not named as a party hereto.
12. FINANCIAL OBLIGATIONS OF THE CITY. All financial obligations of the City under this Agreement are subject to appropriation, budgeting, and availability of funds to discharge such obligations. Nothing in this Agreement shall be deemed to pledge the City's credit or faith, directly or indirectly, to the Contractor. If funds for this Agreement are not appropriated and budgeted in any year subsequent to the fiscal year of execution of this Agreement as determined by the City, this Agreement may be terminated by the City upon written notice to the Contractor. The City's fiscal year is currently the calendar year.
13. EXHIBITS. All exhibits referred to in this Agreement are by reference incorporated herein for all purposes.
14. CONFLICTS WITHIN THE CONTRACT DOCUMENTS. In the event that conflicts exist within the terms and conditions of this Agreement and the attached or referenced exhibits the former shall supersede.
15. INTEGRATION AND AMENDMENT. This Agreement represents the entire agreement between the Parties and there are no oral or collateral agreements or understandings. This Agreement may be amended only by an instrument in writing signed by the Parties. For purposes of clarity, the terms and conditions of any Contractor invoice, Contractor timesheet, or other form, including but not limited to indemnification, limitation of liability, or cancellation fees, shall be void and of no effect against the City notwithstanding any signatures on such form by a City employee. The Contractor's rights and obligations shall be solely governed by the terms and conditions of this Agreement.
16. SEVERABILITY. If any provision of this Agreement as applied to either Party or to any circumstance shall be adjudged by a court to be void or unenforceable, the same shall in no way affect any other provision of this Agreement, the application of any such provision in any other circumstances, or the validity or enforceability of the Agreement as a whole.
17. ADDITIONAL DOCUMENTS OR ACTION. The parties agree to execute any additional documents or take any additional action that is necessary to carry out this Agreement.

18. MINOR CHANGES. The Parties executing this Agreement are authorized to make nonsubstantive corrections to this Agreement and attached exhibits, if any, as they consider necessary.
19. DOCUMENTS. All drawings, analyses, plans, tests, maps, surveys, electronic files and written material of any kind generated in the performance of this Agreement or developed specifically for work performed under this Agreement shall remain the sole and exclusive property of the City, and the other Party shall not provide copies of any such material to anyone without the express written consent of the City.
20. RECORDS RETENTION. The Contractor shall maintain complete and accurate records of time spent and materials used for performance of the Work, together with any invoices, time cards, or other supporting data reasonably requested. All records, data and documentation shall be retained by the Contractor for a period of not less than three (3) years after completion of the Work, and shall be subject to review, inspection and copying by the City upon reasonable notice.
21. OFFICIALS NOT TO BENEFIT. No elected or employed member of City government shall directly or indirectly be paid or receive any share or part of this Agreement or any benefit that may arise therefrom. The Contractor warrants that it has not retained any entity or person, other than a bona fide employee working solely for the Contractor, to solicit or secure this Agreement.
22. SALES TAX EXEMPTION. The Contractor and its subcontractors, consultants and suppliers will not be required to pay Colorado state sales and use taxes on property incorporated into the Work. The Contractor shall obtain a sales tax exemption permit from the State of Colorado Department of Revenue, if necessary, to obtain materials for the Work without the payment of Colorado state sales tax. The Contractor must have a sales tax license, inmate and in-house staff meals are not taxable, but staff purchase of meals are taxable.
23. ASSIGNMENT. This Agreement shall not be assigned by either Party without the prior written consent of the other Party.
24. BINDING EFFECT. This Agreement shall inure to the benefit of and be binding upon the parties and their respective legal representatives, successors, heirs, and assigns, provided that nothing in this paragraph shall be construed to permit the assignment of this Agreement except as otherwise expressly authorized herein.
25. DAYS. If the day for any performance or event provided for herein is a Saturday, a Sunday, a day on which national banks are not open for the regular transactions of business, or a legal holiday pursuant to C.R.S. § 24-11-101(1), such day shall be

extended until the next day on which such banks and state offices are open for the transaction of business.

26. NO PRESUMPTION. The Parties to this Agreement and their attorneys have had a full opportunity to review and participate in the drafting of the final form of this Agreement. Accordingly, this Agreement shall be construed without regard to any presumption or other rule of construction against the Party causing the Agreement to be drafted.
27. GOOD FAITH OF PARTIES. In the performance of this Agreement or in considering any requested approval, acceptance, or extension of time, the Parties agree that each will act in good faith and will not act unreasonably, arbitrarily, capriciously, or unreasonably withhold, condition, or delay any approval, acceptance, or extension of time required or requested pursuant to this Agreement.
28. WAIVER OF BREACH. This Agreement or any of its provisions may not be waived except in writing by a Party's authorized representative. A waiver by any party to this Agreement of the breach of any term or provision of this Agreement shall not operate or be construed as a waiver of any subsequent breach by either party.
29. GOVERNING LAW. This Agreement shall be governed by the laws of the State of Colorado. Venue for any legal action related to this Agreement shall lie in the District Court, Broomfield County, Colorado.
30. LAWS TO BE OBSERVED. The Contractor shall be cognizant of all federal and state laws and local ordinances and regulations that in any manner affect those engaged or employed in the work or which in any manner affect the conduct of the work, and of all such orders and decrees of bodies or tribunals having any jurisdiction or authority over the same, and shall at all times observe and comply with all such existing laws, ordinances, regulations and decrees, and shall protect and indemnify the City against any claim or liability arising from or based on the violations of any such law, ordinance, regulation, order or decree, whether by itself, its subcontractors, agents or employees. The Contractor shall procure all necessary approvals, licenses and permits at its own expense; provided, that, the Contractor will be able to receive no cost permits when such permits are issued by the City directly.
31. TERMINATION. This Agreement may be terminated at any time by either Party upon 120 days written notice to the other Party. In the event of termination, the Contractor shall incur no additional expenses and shall perform no further work for the City under this Agreement after the date of receipt of the notice of termination, unless otherwise specified by the City. The City shall pay the Contractor for all work satisfactorily performed prior to receipt of the notice of termination and for other services required by the City to be completed prior to termination and satisfactorily performed.

32. SURVIVAL OF OBLIGATIONS. Notwithstanding anything to the contrary, the Parties understand and agree that all terms and conditions of this Agreement that require continued performance or compliance beyond the termination or expiration of this Agreement, including without limitation the indemnification provision, shall survive such termination or expiration and shall be enforceable against a Party if such Party fails to perform or comply with such term or condition.
33. DIGITAL ACCESSIBILITY STANDARDS. In 2021, the State of Colorado adopted HB21-1110 relating to the digital accessibility standards required to be implemented under the Colorado Anti-Discrimination Act which makes it unlawful to discriminate against individuals with a disability. In order to comply with the law on or before July 1, 2024, the Contractor shall ensure that all digital deliverables and digital technology provided pursuant to the terms of this Agreement shall comply with at least the Web Content Accessibility Guidelines (WCAG) 2.1 Level AA, or such updated standard as the Colorado Governor's Office of Information Technology may adopt from time-to-time.
34. COOPERATIVE PURCHASING EFFORTS. The City is a member of the Multiple Assembly of Procurement Officials (MAPO) and the Rocky Mountain Governmental Purchasing Association (RMGPA). The Contractor shall permit any member of the MAPO or RMGPA to avail itself of this contract and purchase any and all items specified at the contract prices established herein. Each MAPO or RMGPA member which uses this pricing would establish its own contract, issue its own orders, be invoiced therefrom, and make its own payments. It is understood and agreed that the City is not a legally binding party to any contractual agreement made between a MAPO or RMGPA member and the Contractor.
35. EXECUTION; ELECTRONIC SIGNATURES. This Agreement may be executed in counterparts, each of which shall be deemed an original and all of which shall constitute but one and the same instrument. This Agreement shall not be binding upon any Party hereto unless and until the Parties have executed this Agreement. The Parties approve the use of electronic signatures for execution of this Agreement. All documents must be properly notarized, if applicable.

[The remainder of this page is intentionally left blank.]

This Agreement is executed by the Parties hereto in their respective names as of September 10, 2024.

THE CITY AND COUNTY OF BROOMFIELD,
a Colorado municipal corporation and county

Mayor
One DesCombes Drive
Broomfield, CO 80020

APPROVED AS TO FORM:

City and County Attorney's Office

CONTRACTOR:

Trinity Services Group, Inc.

By: 
James M. Perry, Senior Vice President, Sales
Address: 477 Commerce Blvd., Oldsmar, FL 34677

EXHIBIT A
SCOPE OF WORK

The Contractor shall provide inmate food, commissary and trust fund accounting services (“Inmate Food Services”) as follows:

1. Inmate Food Service. For Inmate Food Services, the Contractor shall provide all consumable supplies and food products that are required for the food service operations including the following:
 - a. Inmate meals rotating on an eight (8) week schedule. Three (3) different eight-week menus, complete with nutritional analysis will be made available to Detention management.
 - b. Staff meals rotating on a four (4) week schedule.
 - i. Provide options for staff meals that can be stored and reheated without compromising taste or time.
 - ii. Staff are unable to leave the Detention Center for lunch but can bring in their own meals from home. Officers provide kitchen staff with a total count of staff meals requested per day, which also includes a meal for the graveyard officers to heat up and eat during their shift.
 - iii. The Contractor may serve up to 37 meals per day to staff and visitors, which could include salads. These meals shall be paid for by the City by the number of meals served, or the number ordered per day, whichever is greater. A process will be established for staff to purchase meals at the same rate of officer meals.
 - c. Three (3) meals will be served, seven (7) days a week for inmates, with a minimum of two (2) hot meals served each day.
 - i. The Contractor shall assure that all meals will be served at appropriate temperatures and in the manner that makes them palatable (140 degrees if hot, 45 degrees if cold) be visibly pleasing, and complete with condiments (dressing, sugar, salt, pepper, catsup, mustard, or mayonnaise where indicated). Salt and pepper shakers are taken to the housing pds, counted and returned to the kitchen.
 - ii. The Contractor shall not use any United States Department of Agriculture donated or distressed products nor any secondary market commodities.
 - d. Special inmate meals on holidays and special events. The Contractor will provide policies for service special meals on holidays, including menus for those holidays. All holidays will be provided at the standard contract rates. A minimum of six (6) special holiday meals will be provided annually including,

- Easter, Thanksgiving, Christmas, and New Years holidays, and two (2) meals to be scheduled at the discretion of the Detention staff annually.
- i. The Contractor must provide a minimum of two (2) hot meals on holidays.
- e. Special dietary and religious meals conforming to special religious or physician ordered specifications shall be provided at no additional cost to the City, including:
- i. Dietician Menu
 - ii. Special diets
 - iii. Vegetarian diets
 - iv. Vegan diets
 - v. Medical diets
 - vi. Other religious diets including but not limited to:
 1. Kosher
 2. Ramadan
 3. Lent
- f. Sack lunches. Sack lunches may be needed for specific events and will be coordinated with the Contractor in advance. Sack lunches are also provided to ASU inmates.
- g. All menus and special diets must meet the standards for adult holding and detention facilities established by the American Correctional Association. A registered dietician will approve all menus prior to use.
- h. All meals served will be in compliance with the National Academy of Sciences and Food standards and will provide an average of 2,900 calories per day, in addition to the required nutrients. Menus will describe portions sizes and substitutes.
- i. Four (4) free catered meals for Detention Center hosted events included in the contract price, no more than 75 meals. The Contractor will be provided not less than 72 hours notice of special events.
- i. One (1) Colorado Jail Association Meeting
 - ii. One (1) Command Staff Retreat
 - iii. Two (2) Other Annually Hosted Events
- j. The Contractor should use commercially reasonable effort to use local supplies, as available while not compromising product or price.
- k. High quality meals which will be tasted regularly by Detention Center staff.
- i. The Contractor may be asked to provide samples of suggested products to the City, free of charge, so the managers can ascertain the most

acceptable and appropriate products to meet the Detention Center's needs. Sampling will be required throughout the term of the Agreement. The Detention Center will be the sole judge of acceptable products.

- l. At a minimum of once a week liquid milk will be provided.
- m. Sufficient staff to prepare all meals with no assistance from inmate workers. Inmate workers are only used for washing dishes and will under no circumstances assist with the preparation or handling of food.
- n. Delivery and Location. The Contractor shall deliver all items to the Broomfield Detention Center located at 11600 Ridge Parkway, Broomfield, CO 80021. Deliveries shall only be allowed between the hours of 7:00 am to 10:30 am and 12:00 pm to 4:00 pm Monday through Friday, excluding the holidays New Years Day, Easter, July 4th, Thanksgiving and Christmas Day.
 - i. The Contractor will not be permitted to use staffing companies and any third-party sources for loading and unloading of the Contractor's delivery trucks to the ground. Delivery drivers for the food services distributor, may assist in unloading to the ground.
 - 1. At no time will Detention Center staff or inmate workers be permitted or available to assist in loading, unloading or any other support to the Contractor providing Services.
 - 2. The Contractor's staff may use the City's fork lift with valid and updated credentials to unload deliveries if necessary.
 - 3. Once deliveries are on the ground, Detention staff and outside cleared inmate workers may be utilized to move deliveries into the kitchen if the Contractor's staff requires assistance.
- o. The Contractor must use paper storage containers, no styrofoam is allowed in the secured perimeter of the Detention Center.
 - i. Alternative Sentencing Unit (ASU) inmate meals are to be delivered in disposable containers as no food return containers will be sent into the ASU. Nothing is returned from the ASU.
- p. The Contractor shall provide alternative utensils for suicidal inmates. These utensils must be made of a material that prevents an inmate from altering or using to harm themselves.
- q. The Contractor shall provide and maintain an adequate amount of excess emergency consumable supplies to feed both the total number of inmates and employees within the Detention Center for a period of at least 72 hours.

- r. Inspections. Inspections of kitchen facilities by the County and State health agencies must achieve satisfactory ratings. If such ratings are not satisfactory, the Contractor must notify the City of areas to be improved, and shall effectuate such necessary measures to remedy the deficiencies within fifteen (15) calendar days of receipt of the results of such inspection.
 - s. Feedback. The Contractor shall mutually design with the Detention staff a performance satisfaction survey to minimally include a program to solicit feedback with reporting of history and trends.
2. Inmate Commissary Services. For Inmate Commissary Services, the Contractor will provide onsite management of commissary services to include the purchase, storage, inventory management, billing, and packaging of products for distribution to the inmates. The Contractor must also be able to refund any out of stock products charged to an inmate that is not distributed. The Contractor must accomplish this without the assistance of inmate workers. The Inmate Commissary Services shall include the following:
- a. All purchased products will meet all applicable standards and guidelines with all correctional safety requirements and will meet prior approval from Detention staff before being sold to the inmate population. All inventory shall be maintained on site at existing spaces identified for such purpose.
 - b. The Contractor shall provide all necessary hardware and software to provide a complete system to manage the commissary process with secure login User IDs and passwords. The services shall include a negotiated order guide/menu of available commissary items to select from and be flexible in the modification to add/delete items. The Contractor must provide 14 days prior notice when changing menu items unless an emergency situation is encountered.
 - c. A back up manual system shall be established for when internet access or the on-line direct order entry system is unavailable. The ability for inmates to order commissary services over the phone system, currently provided through the inmate phone system Securus Technologies, or via paper orders completed by inmates within the housing units. If orders are collected by paper, the Contractor must maintain a records keeping system for future reference as needed.
 - d. Inmate accessible kiosks are not permitted within the Detention Center for the purposes of ordering commissary services. The Contractor may offer alternative supports for consideration of the Detention Center staff.
 - e. Flexibility to offer special items for City observed holidays.

- f. Inmate Commissary Services are provided three times (3) a week. Provide the inmate with detailed receipt listing items purchased and store data electronically for Detention staff review. The Contractor shall provide clear commitments on back ordered or substituted items, including time for delivery if not within 24 hours.
 - g. Processing of orders and deducting real time from inmate account balances. The Contractor shall ensure that orders are not filled resulting in a debit/negative balance with the exception of pre-defined indigent processing rules to be provided by the City. The Contractor will provide a toll-free customer service number available 24 hours per day/365 day per year.
 - h. Orders shall be packed in clear sealed bags per housing locations. Detention staff will distribute the bagged orders.
 - i. Accommodate multiple commissary menus which may be defined by housing area.
 - j. Monthly invoices for commissary payments and submission of monthly commissions earnings/credits, will be submitted with the payment invoice each month as set forth in Section 3 of this Agreement.
 - k. The Contractor shall review commissary pricing and strategies with Detention staff at least bi-annually. The Contractor shall also provide all necessary training of Detention staff to support the services.
3. Inmate Trust Fund Accounting System. Currently, the Detention Center is utilizing the Inmate Trust Fund Accounting System (“Inmate Accounting System”) Lockdown. The City will consider other Inmate Accounting Systems which include at a minimum:
- a. Banking software and hardware to provide generally accepted privacy principals (GAPP) accounting functions and principals required to maintain inmate trust accounts and bank accounts with functions including:
 - i. Open and reopen inmate accounts;
 - ii. Close and release inmate accounts;
 - iii. Add funds to accounts;
 - iv. Edit inmate accounts;
 - v. Allow for cost recovery of medical and other facility charges;
 - vi. Reports for all transactions, including standard practice general ledger reporting;
 - vii. Receipt for all transactions;
 - viii. Produce checks and/or debit cards for inmate release credit funds;
 - ix. Produce checks for other payments from inmates or facility accounts;
 - x. Void, un-void, and reprint checks;

- xi. Daily balancing and deposit tracking for cash drawers;
 - xii. Automated transfer into inmate and facility accounts for electronic deposits;
 - xiii. Unique user ids and passwords per individual; allow access level distinctions;
 - xiv. Process to transfer funds to/from City bank accounts;
 - xv. Process to reconcile bank accounts with bank statements;
 - xvi. Allow for bonds to be added and checks written to appropriate courts; if account has debit balance, specific bond deposits shall not apply to other debt;
 - xvii. Accept electronic updates of mass data to load current image and bank account history;
 - xviii. Mitigate existing inmate account details and balances into new environments as needed; and
 - xix. Allow friends and family to add funds to inmate accounts.
- b. A kiosk placed in the main lobby of the Detention Facility for family and friends to deposit money to an inmate's account.
- i. This kiosk must be able to accept credit cards, debit cards and cash.
 - ii. This kiosk and all software must also be compliant with the City's digital accessibility requirements as set forth in Section 34 of the Agreement.
 - iii. Kiosk must be able to detect counterfeit bills.
- c. Providing any necessary integration required with the jail management system.
- d. Receiving funds from an inmate during the booking process and the bonding process. Funds are defined as any paper currency, including checks, the inmate has on their person at the time of arrest, which is added to the Inmate trust fund account during the booking process.
- e. Billing inmates both automatically and manually, with the ability to customize billable items and their automation.
- f. The ability to pay a bond without the need to pay debt owed to the Detention Center.
- g. The ability to provide detailed reports and documentation for a variety of internal and external users which may include at a minimum Detention Center Staff, Finance staff, inmates, or inmates friends and family.
- i. Reports may include but are not limited to account balance details with transaction dates, details amounts and running balance, billing and deposit receipts with transaction date, details and amount of bill or

deposit, reconciliation reports, and any other financial documentation that could be requested for an audit.

- h. Allow for customizable user permissions to group staff into the appropriate settings for their based on the staff position.
- i. Ability to integrate with AllPaid, GovPay.Net, for acceptance of debit and credit cards when bonding.
- j. Administrative functions for daily cash drawer consolidations, deposits and monthly bank reconciliations.
- k. The Inmate Accounting System should have the ability to release inmates with any remaining funds onto a pre-loaded debit card, following all applicable laws and regulations at both the State and Federal level.
 - i. Inmates who are released from custody are to be issued a pre-loaded debit card managed by a third-party vendor with any funds remaining on their Inmate trust account, transferring liability of the funds to the third-party vendor from the Detention Center.
 - ii. Any cost for doing business with the third-party vendor is at the expense of the Contractor.
- l. The ability to issue checks with the correct magnetic ink character recognition line (“MICR”) font and customizable template that will print on blank check paper. Customizations to check must include the tracking and automation of the check number, Detention Center name and address, a memo field and the routing and account number.
- m. *Change to Software System or Inmate Accounting System.* If a change in the software or Inmate Accounting System is accepted as part of this Agreement, the Contractor shall provide the following:
 - i. The Contractor and software developer must be available onsite for a one (1) week onboarding, training and implementation of the new system.
 - ii. Any software changes or upgrades must be accompanied with updated training resources and guides to be distributed among current Detention Center staff for the purposes of updated training and to update training for newly hired staff as needed.
 - iii. Provide adequate and detailed training resources and guides for the Detention Center to utilize when training newly hired staff.

- iv. The Contractor's software developer, if not the Contractor, must be available for up to twelve (12) meetings per year, as requested by the Detention Center.
4. Schedule of Work and Transition of Services. The full transition of Services is intended to occur on November 1, 2024, at which time the Contractor shall begin providing all Services. The Contractor is required to provide the following:
- a. A detailed plan describing the transition process, including proposed menus, to be used in the assumption of operations effective no more than thirty (30) days from the contract award date.
 - b. Upon anticipated approval from the City Council, the transition is expected to begin on September 11, 2024 and be completed forty-five (45) days later.
 - c. If the incumbent Contractor is not awarded the new contract, the incumbent Contractor may be required to continue providing products and services, in order to provide the Detention Center with continued operations. The Contractor shall ensure that any incumbent Contractor's operations will be included as part of the transition plan to ensure a smooth transition, and minimal impact to Detention Center operations and inmates.
 - d. The transition plan shall specify all tasks to be accomplished, responsible parties for each task, and time frames of each task's start and end time.
 - i. The transition plan shall include detailed information such as the duties and responsibilities performed of all Contractor staff assigned to complete this phase, and their roles.
 - e. The transition plan shall be accomplished at the Contractor's expense and shall not be reimbursed under this Agreement.
 - f. In the course of the transition plan, the Contractor shall minimize any disruption of Services under the existing operations.
 - g. As part of the transition plan, interfaces to the current systems which include Securus Technologies for inmate phones and Lockdown for inmate accounting to ensure full functionality at the completion of the transition plan.
 - h. The City and the Contractor will coordinate to facilitate the purchase by the City, or the successor food service provider to purchase, all usable supplies and food products at the Contractor's invoice cost.
5. Staffing.

- a. Any staff employed by the Contractor will be required to pass a background check conducted by the Broomfield Police Department Background Investigators seven (7) days prior to their first day working on-site in order to be granted access to the secure areas of the Detention Center. The kitchen is located within the secure perimeter of the Detention Center.
 - i. Food services personnel will also be required to complete periodic health examinations at least as frequently and as stringent as required by law, and to submit satisfactory compliance to the City upon request.
 - ii. Contractor staff may also be subject to polygraph Computer Voice Stress Analyzer (CVSA) testing and clearance by the City. The City reserves the right to disqualify any staff from working at the Detention Center for any reason.
 - b. The Contractor shall assign the number of employees needed per shift to handle all aspects of the food service operation.
 - i. The Contractor must provide all staffing, inmates will not be used for assistance. The City will be responsible, through the use of image workers, for sweeping, mopping, trash removal and washing dishware, pans and trays, utensils are excluded.
 - ii. The Contractor shall be responsible for routine cleaning and housekeeping of food service preparation, service and storage areas; and will on a continuing basis, maintain standards of sanitation required by applicable law. The Contractor shall supply cleaning supplies for the kitchen and food service area which are environmentally friendly.
 - c. The Contractor shall provide an organizational chart and job description for all professional staff included in managing the City's inmate food service. The Contractor shall schedule a quarterly management meeting with the Detention Commander and Detention management staff.
 - d. The Contractor shall have 24 hour access to dietician support.
 - e. All of the Contractor's employees must comply with the City's written policies and procedure relating to security at the Detention Center. Failure to do so, will be grounds for dismissal of individual employees and possible termination of the Agreement by the City.
6. Kitchen Equipment Ownership. For purposes of clarity, the City owns all of the equipment and utensils in the kitchen and will continue to supply the kitchen with replacement equipment as needed on an annual basis, up to \$1,500. The Contractor claims ownership only to the food and ingredients used to make the food. Sporks and

cups are issued to arrestees at booking and retrieved as release. The Contractor will provide all other small wares (e.g. serving spoons, ladles etc.) at its own expense.

- a. At the expiration or termination of the Agreement, the Contractor shall return to the City all equipment furnished by the City in the condition in which it was received, reasonable wear and tear excepted.
- b. If the equipment has been lost or damaged by fire, flood, or unavoidable occurrence, or stolen by persons other than employees of the Contractor without negligence on the part of the Contractor or its employees, and providing that all such damage and losses are reported to the City in a reasonable period of time, for all items covered by this paragraph, the City will pay for the needed repairs or replacement caused by normal wear and tear.

EXHIBIT B
PRICE SCHEDULE

TRINITY SERVICES GROUP Inmate Population Sliding Scale Broomfield Police Department		
FROM:	TO:	PRICE
29	38	\$9.077
39	48	\$7.017
49	58	\$5.798
59	68	\$4.992
69	78	\$4.420
79	88	\$3.993
89	98	\$3.661
99	108	\$3.397
109	118	\$3.191
119	128	\$3.019
129	138	\$2.875
139	148	\$2.750
149	158	\$2.643
159	168	\$2.549
169	178	\$2.466
179	188	\$2.393
189	198	\$2.327
199	AND OVER	\$2.268

Staff Price: \$4.00/meal

The Contractor shall provide 27 % of all commissary sales to the City, and such funds shall be deposited into the Inmate Welfare account to be used to pay costs associated with the educational, recreational, and program supplies for inmates. This was reduced from 28% to 27% after the bid proposal due to CCOB and Trinity agreeing that the Inmate Accounting System Lockdown would continue to be used.

EXHIBIT C
INSURANCE REQUIREMENTS

**CITY and COUNTY of BROOMFIELD INSURANCE REQUIREMENTS - Including
Professional Liability**

8/29/24-Vendor is providing and it will
be attached.

Vendor/Contractor/Subcontractor shall obtain and maintain, at its own expense and for the duration of the contract including any warranty periods under which the Contract are satisfied, the following:



City of Broomfield

City Council Regular Meeting

Proposed Resolution to Replace Existing Police Mobile Radios

Meeting	Agenda Group
Tuesday, September 10, 2024, 6:00 PM	Consent Items Item: 6C
Presented By	
Enea Hempelmann, Chief of Police	
Community Goals	
<input checked="" type="checkbox"/> Thriving, Diverse, Safe and Welcoming Community	

Overview

[View Correspondence](#)

The Broomfield Police Department is seeking Council approval to purchase replacement mobile vehicle radios for police use through Broomfield's Capital Improvement Program (CIP) Asset Replacement. If approved, this request will authorize the replacement of 91 mobile vehicle police radios, ensuring the Police Department's radio equipment remains up to date. Currently, 91 Motorola mobile vehicle radios (Model APX6500-AN) are scheduled to reach their end-of-life on December 31, 2025. These radios are vital tools used daily by police officers to fulfill their duties. After its end-of-life date, the current equipment will no longer be eligible for support, repairs, preventative maintenance, or upgrades.

Attachments

[Council Memo for Motorola Mobile Radios.pdf](#)

[Resolution 2024-110-with Motorola for Replacement of Existing Mobile Radios.pdf](#)

[Motorola Mobile Radio Quote.pdf](#)

Memo for: Replacement of Existing Police Department Mobile Vehicle Radios
 Prepared By: Enea Hempelmann, Chief of Police
 Mark Goodell, Deputy Chief of Police
 Jacinda English, Public Safety Telecommunications Manager

Summary

[View Correspondence](#)

The Broomfield Police Department is seeking Council approval to purchase replacement mobile vehicle radios for police use through Broomfield’s Capital Improvement Program (CIP) Asset Replacement. If approved, this request will authorize the replacement of 91 mobile vehicle police radios, ensuring the Police Department’s radio equipment remains up to date.

Currently, 91 Motorola mobile vehicle radios (Model APX6500-AN) are scheduled to reach their end-of-life on December 31, 2025. These radios are vital tools used daily by police officers to fulfill their duties. After its end-of-life date, the current equipment will no longer be eligible for support, repairs, preventative maintenance, or upgrades. Council has previously approved similar replacement projects. Most recently, a similar process was completed in 2023 by the police department for the portable (handheld) radios, which were replaced due to their end of life as authorized by Resolution 2023-108.

Motorola Solutions, Inc., Broomfield’s current vendor for the radio system, presented a quote (attached) for the replacement of the 91 radios. Motorola will provide the replacement equipment. The quoted price includes hardware, programming, and warranty costs. Installation and programming will be a project managed by Broomfield Fleet Services over the course of several months, starting once the hardware is delivered.

Financial Considerations

As shown in the sources and uses of funds summary below, the project was submitted as a 2024R Mid-Year CIP Budget Submission and can be completed within the proposed 2025 budget, if approved.

Sources and Uses of Funds	Amount
CIP Equipment Replacement for APX6500-AN mobile vehicle radios 20-70111-55600 Project Code 22S0030 (2024R Mid-Year CIP Budget Submission- Oct 24)	\$599,439.75
(91) APX6500-AN Mobile Radios	-\$599,439.75
Projected Balance	\$0.00

Prior Council or Other Entity Actions

[Resolution 2011-26 and Resolution 2011-6](#) Budget Amendment-Authorized Urban Area Security Initiative for Police Radios.

[Resolution 2011-194](#) Authorized the Purchase of Replacement Police Radios Utilizing CIP Funds

[Resolution 2012-155](#) Authorized the Purchase of Replacement Police Radios Utilizing CIP Funds

[Resolution 2013-187](#) Authorized the Purchase of Replacement Police Radios Utilizing CIP Funds

Boards and Commissions Prior Actions and Recommendations

N/A

Proposed Actions / Recommendations

If Council desires to authorize the expenditure with Motorola Solutions, Inc. for the replacement of radios, appropriate motion is...

That Resolution 2024-110 be adopted.

Alternatives

The Police Department would continue to operate with the possibility of severely limited radio communications and increased risk of equipment failure. The current equipment will no longer be eligible for service or maintenance upgrades after December 31, 2025. As the entire public safety radio system and all existing hardware are currently provided and supported by Motorola, seeking alternative options would not only be cost-prohibitive but would cause significant connectivity issues.

RESOLUTION NO. 2024-110

A resolution approving the replacement of existing Police Department mobile vehicle police radios

Section 1.

A purchase from Motorola Solutions, Inc. for the replacement of existing Police Department mobile vehicle police radios is approved as set forth below.

Section 2.

The City and County Manager, or her designee, is authorized to approve a purchase order to Motorola Solutions, Inc. not to exceed the amount of \$599,439.75 for the purchase of replacement existing Police Department mobile radios.

Section 3.

The City and County Manager or a designee is authorized to approve change orders in aggregate amounts up to ten percent of the quoted amount.

Section 4.

This resolution is effective upon its approval by the City Council.

Approved on September 10, 2024.

The City and County of Broomfield, Colorado

Mayor

Attest:

Office of the City and County Clerk

Approved as to form:

NCR

City and County Attorney

Billing Address:
 BROOMFIELD POLICE DEPT,
 CITY OF
 1 DESCOMBES DR
 BROOMFIELD, CO 80020
 US

Shipping Address:
 BEARCOM OPERATING LLC
 3901 W SERVICE RD
 EVANS, CO 80620
 US

Quote Date:05/22/2024
 Expiration Date:07/19/2024
 Quote Created By:
 Wes Chisnall
 Account Manager
 wes.chisnall@bearcom.com
 970-590-3461

End Customer:
 BROOMFIELD POLICE DEPT, CITY OF
 Sven Evelsizer
 sevelsizer@broomfield.org
 303-464-5680

Contract: 19860 - NASPO 00318
 Payment Terms:30 NET

Line #	Item Number	Description	Qty	List Price	Sale Price	Ext. Sale Price
	APX™ 6500 / Enh Series	ENHANCEDAPX6500				
1	M25URS9PW1BN	APX6500 ENHANCED 7/800 MHZ MOBILE	91	\$3,383.12	\$2,469.68	\$224,740.88
1a	GA09008AA	ADD: GROUP SERVICES	91	\$165.00	\$120.45	\$10,960.95
1b	G831AD	ADD: SPKR 15W WATER RESISTANT	91	\$66.00	\$48.18	\$4,384.38
1c	G996AS	ENH: OVER THE AIR PROVISIONING	91	\$110.00	\$80.30	\$7,307.30
1d	GA00580AA	ADD: TDMA OPERATION	91	\$495.00	\$361.35	\$32,882.85
1e	G51AU	ENH: SMARTZONE OPERATION APX6500	91	\$1,320.00	\$963.60	\$87,687.60
1f	G67DT	ADD: REMOTE MOUNT E5 APXM	91	\$327.00	\$238.71	\$21,722.61
1g	G78AT	ENH: 3 YEAR ESSENTIAL SVC	91	\$288.00	\$288.00	\$26,208.00
1h	GA01606AA	ADD: NO BLUETOOTH/ WIFI/GPS ANTENNA NEEDED	91	\$0.00	\$0.00	\$0.00
1i	G843AH	ADD: AES ENCRYPTION AND ADP	91	\$523.00	\$381.79	\$34,742.89



Any sales transaction following Motorola's quote is based on and subject to the terms and conditions of the valid and executed written contract between Customer and Motorola (the "Underlying Agreement") that authorizes Customer to purchase equipment and/or services or license software (collectively "Products"). If no Underlying Agreement exists between Motorola and Customer, then Motorola's Standard Terms of Use and Motorola's Standard Terms and Conditions of Sales and Supply shall govern the purchase of the Products.
 Motorola Solutions, Inc.: 500 West Monroe, United States - 60661 - #: 36-1115800

Line #	Item Number	Description	Qty	List Price	Sale Price	Ext. Sale Price
1j	G444AH	ADD: APX CONTROL HEAD SOFTWARE	91	\$0.00	\$0.00	\$0.00
1k	G806BL	ENH: ASTRO DIGITAL CAI OP APX	91	\$567.00	\$413.91	\$37,665.81
1l	GA01670AA	ADD: APX E5 CONTROL HEAD	91	\$717.00	\$523.41	\$47,630.31
1m	W22BA	ADD: STD PALM MICROPHONE APX	91	\$79.00	\$57.67	\$5,247.97
1n	W969BG	ADD: MULTIKEY OPERATION	91	\$363.00	\$264.99	\$24,114.09
1o	G174AD	ADD: ANT 3DB LOW-PROFILE 762-870	91	\$47.00	\$34.31	\$3,122.21
1p	G361AH	ENH: P25 TRUNKING SOFTWARE APX	91	\$330.00	\$240.90	\$21,921.90
1q	QA09113AB	ADD: BASELINE RELEASE SW	91	\$0.00	\$0.00	\$0.00
2	LSV00Q00202A	DEVICE PROGRAMMING	91	\$100.00	\$100.00	\$9,100.00

Grand Total **\$599,439.75(USD)**

Notes:

- Unless otherwise noted, this quote excludes sales tax or other applicable taxes (such as Goods and Services Tax, sales tax, Value Added Tax and other taxes of a similar nature). Any tax the customer is subject to will be added to invoices.





Proposed Resolution with North Metro for Temporary Fire Station

Meeting	Agenda Group
Tuesday, September 10, 2024, 6:00 PM	Consent Items Item: 6D
Presented By	
Ken Rutt, Director of Public Works	
Community Goals	
<input checked="" type="checkbox"/> Financial Sustainability and Resilience	

Overview

[View Correspondence](#)

The applicant, North Metro Fire Rescue District (NMFRD), has submitted an application to address the District's need to build a Fire Station in the area of 112th and Simms. A temporary location for Fire Station 68 is required during the construction period for the new facility (the Temporary Project Site). The proposed temporary location is the southwest corner of the Water Reclamation Facility located at 12400 W. 112th Avenue, west of Simms street. This agenda memorandum addresses the application for a temporary location.

Attachments

[Memo for North Metro Revocable Permit.pdf](#)

[Resolution No. 2024-95.pdf](#)

[W_COI - Broomfield Agreement - Grant of revocable permit - vendor signed 8-12-24 \(1\).pdf](#)

Summary

[View Correspondence](#)

The North Metro Fire Rescue District (NMFRD) provides fire protection services to the City and County of Broomfield in addition to Northglenn and unincorporated areas of Adams, Boulder, Jefferson, and Weld counties.

NMFRD currently has [5 fire stations](#) located in Broomfield. NMFRD has identified the need to expand their coverage area in the southwest section of Broomfield with the addition of a new Fire Station (Station 68) in the area of 112th and Simms. NMFRD desires to access the City property for the purpose of installing a temporary fire station with suitable access to Simms Street while a new fire station is being constructed.

Staff worked closely with NMFRD to identify temporary locations for the equipment and firefighters during this construction. The proposed site met NMFRD operational needs. The proposed NMFRD temporary site will not interfere with Public Works Operations and Maintenance and will provide added security due to the 24 hour staffed temporary Fire Station 68 at the Great Western Water Reclamation Facility.

During the construction of Station 68, NMFRD has requested a “Grant of a Revocable Permit to Use and Occupy City Owned Property located at 12400 W. 112th Avenue”. The proposed temporary location is the southwest corner of the Great Western Water Reclamation Facility.

The location is approximately one quarter mile away from the nearest residential unit within the Skystone development.

The temporary fire station will consist of a temporary trailer on the north end for housing staff and a durable tent-like enclosure will be located on the south end of the site for the fire apparatus equipment. Primary access would be provided from 112th Avenue on the existing road. The engine structure will be set on the existing pavement, the housing structure, and gravel parking will be placed on the existing turf. The temporary station is similar to the temporary station that operated at the northwest corner of 1st Avenue and Spader Way when Station 61 was rebuilt.

The temporary location is requested for use by NMFRD for up to one year during the construction period for the permanent, new station on 112th Avenue and Simms Street. A revocable permit agreement is proposed to address the temporary use on the site and restoration of the site conditions once the temporary facilities are removed.

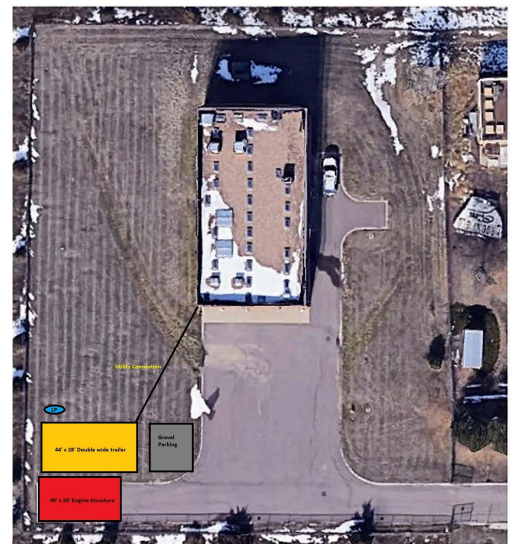
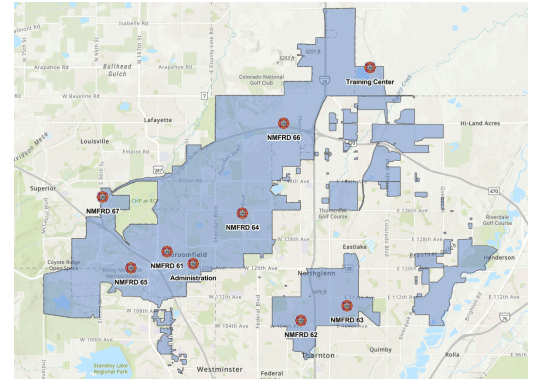

If the revocable permit is approved, NMFR will be required to obtain permits through the Building and Engineering Divisions of Community Development and provide an administrative modification to the approved site development plan for the Water Reclamation Facility site. Staff will share information regarding the temporary station with the Skyestone Homeowners association. The temporary station is not anticipated to have a negative impact on the neighborhood since there is already construction in the area between the station and the neighborhood as part of the Simms Technology Park. Skyestone residents have previously expressed support for a new fire station to improve response times within their neighborhood.

Proposed Resolution No. 2024-95 would approve the revocable permit for the temporary project site at 12400 W 112th Avenue.

Financial Considerations

There is no financial impact to Broomfield.

Prior Council or Other Entity Actions

Prior Council Action: none

Proposed Actions / Recommendations

If Council desires to proceed with the revocable permit, the appropriate motion is...

That Resolution 2024-95 be adopted.

Alternatives

Do not approve the revocable permit. North Metro Fire Rescue District will need to find a new temporary location.

RESOLUTION NO. 2024-95

A resolution approving a Revocable Permit with North Metro Fire Rescue District for a Temporary Fire Station located at the City's Great Western Water Reclamation Facility

Be it resolved by the City Council of the City and County of Broomfield, Colorado:

Section 1.

The Revocable Permit between the City and County of Broomfield and North Metro Fire Rescue District for a temporary fire station at the City's Great Western Water Reclamation Facility located at 12400 W. 112th Avenue, Broomfield, Colorado is approved.

Section 2.

The Mayor or Mayor Pro Tem is authorized to sign and the Office of the City and County Clerk to attest the Revocable Permit, in form approved by the City and County Attorney

Section 3.

This resolution is effective upon its approval by the City Council.

Approved on September 10, 2024

The City and County of Broomfield, Colorado

Mayor

Attest:

Office of the City and County Clerk

Approved as to form:

KKH

City and County Attorney

AN AGREEMENT BY AND BETWEEN THE CITY AND COUNTY OF BROOMFIELD AND NORTH METRO
FIRE RESCUE DISTRICT FOR THE GRANT OF A REVOCABLE PERMIT TO USE AND OCCUPY CITY
OWNED PROPERTY
LOCATED AT
12400 W 112TH AVENUE
BROOMFIELD, CO 80021

1.0 **PARTIES.** The parties to this Agreement for the Grant of a Revocable Permit (this "Agreement") are the City and County of Broomfield, a Colorado municipal corporation and body politic and corporate of the State of Colorado (the "City"), and North Metro Fire Rescue District, a political subdivision of the State of Colorado (the "Fire District"), collectively, the "Parties," or individually, a "Party."

2.0 **RECITALS AND PURPOSE.**

2.1. Whereas the Fire District requires a temporary off-site location for operations associated with building a permanent station in the 112th/Simms area during the construction of the new Fire Station;

2.2. The City owns certain property (the "Property") located at 12400 W 112th Avenue, Broomfield, CO 80021, on which a temporary Fire Station may be located at the southwest corner of the City's Water Reclamation Facility (hereinafter referred to as the "Temporary Use Area"). The Temporary Use Area is approximately 3,000 square feet and is shown in exhibit A.

2.3. The Fire District desires to access the City property for the purpose of installing a temporary fire station with suitable access to Simms Street while a new fire station is being constructed as indicated on **Exhibit B**, attached hereto and incorporated herein (the "Facilities").

2.4. The City desires to grant a revocable permit to the Fire District under the terms and conditions as provided in this Agreement.

3.0 **TERMS AND CONDITIONS.** For and in consideration of the mutual covenants and promises contained herein, the sufficiency of which is acknowledged, the Parties agree as follows:

3.1. **Grant of Permit.** The City hereby grants to the Fire District a revocable permit for right to construct, maintain, operate, repair, inspect, remove and replace the Facilities, as depicted on **Exhibit B** within the Property as described herein until such permit is terminated as provided herein (the "Revocable Permit"). The Fire District acknowledges and agrees that the City currently uses and intends to continue to the use the Property for the operation of the Water Reclamation Facility, and the rights granted to the Fire District for use of the Property are subject to the rights of the City to use the Property for the

operation of the Water Reclamation Facility and for any and all other purposes as may be permitted by law, which the City expressly reserves.

- 3.2. **Construction and Alterations.** The Fire District agrees to construct any structures or improvements placed in the Property at the expense of the Fire District. The Fire District shall not begin any construction or alteration of the Property until the Fire District first provides the City with plans and specifications, and such plans and specifications have been approved by the City. In addition, the Fire District shall obtain any other permits required for the construction, including but not limited to a Public/Private Improvement Permit, as applicable. If the Fire District's construction requires any deviation in any manner from the approved plans and specifications, the Fire District shall notify and obtain prior written approval from the City for any changes in advance of any construction or alteration. Any damage to existing facilities located on the Property as a result of the Fire District's construction or alteration of the Facilities shall be paid for by or repaired at the expense of the Fire District. These provisions shall also apply to any other work involving the maintenance, operation, repair, inspection, removal, replacement, or relocation of the Facilities on the Property. After initial construction of the Facilities and thereafter, in the event of resettling, the Fire District shall restore the surface of the Property by grading and compacting any irregularities, reseeding, and/or revegetation as required to restore original conditions, as applicable.
- 3.3. **Maintenance and Repair.** The Fire District agrees to maintain, and repair any structures or improvements placed in the Property at the expense of the Fire District and in accordance with Section 3.2 above. The Fire District agrees that the City is not and will not assume any liability, responsibility, or costs for any damage or maintenance to any Facilities erected by the Fire District on the Property under this Agreement.
- 3.4. **Prior Rights.** This Revocable Permit is issued subject to any prior permits, easements, leases or other rights granted by the City, or its predecessors, for improvements of other parties. The City reserves the right to permit others to install improvements in, on, under, or along the Property. The Fire District acknowledges that utilities may be located in and under the Property. The Fire District is advised to contact the Utility Notification Center of Colorado (1-800-922-1987) at least two (2) working days prior to the commencement of construction on the Property to arrange for field locating of utility facilities which may affect the Property.
- 3.5. **Termination.** The use and occupancy described in the Revocable Permit shall continue from the date of this Agreement to the time that this Agreement is terminated. The City may terminate this Agreement at any time by giving written notice to the Fire District ten days in advance of the effective date of termination and specifying the date of termination therein. Upon termination of this Agreement by the City pursuant to this section, Fire District shall, at its expense, remove the Facilities from the Property and restore the general

surface of the Property, as nearly as may reasonably be, to the grade and conditions it was immediately prior to the placement of the Facilities on the Property. The Fire District shall obtain any permits required for the removal of the Facilities, including but not limited to a Public/Private Improvement Permit, as applicable.

- 3.6. **Release.** The Fire District agrees that it will never institute any action or suit at law or in equity against the City or any of its officers or employees, nor institute, prosecute, or in any way aid in the institution or prosecution of any claim, demand, or compensation for or on account of any damages, loss, or injury either to person or property, or both, known or unknown, past, present or future, arising from the Revocable Permit granted to Fire District. The Fire District hereby releases and absolves the City, its agents and employees, from any liability for any damage to any of the Facilities on the Property that may be caused by City construction or maintenance operations, or any other reason, including, but not limited to, removal, piling and plowing of snow, and from any liability for any injury or damage incurred by the Fire District in their use of the Facilities on the Property.
- 3.7. **Indemnification.** To the extent permitted by law, the Fire District expressly agrees to indemnify, defend and hold harmless the City and any of its officers or employees from any and all claims, demands, damages, court awards, including any costs and attorney's fees, that are or may be awarded as a result of any loss, injury or damage sustained or claimed to have been sustained by anyone, or any liability whatsoever from or, arising out of, the execution of this Revocable Permit by the Parties, or the presence of any Facilities or improvements by, or the use of the Facilities by the Fire District, its employees or agents.
- 3.8. **Insurance.** To assure the City that the Fire District is always capable of fulfilling specified indemnification obligations, the Fire District shall purchase and maintain insurance of the kind and in the amounts required by the City, from an insurer with an AM Best FSR rating of A- or higher as more particularly set forth on Exhibit C. Current proof of such insurance is attached at Exhibit C, incorporated by this reference. However, proof of insurance attached as Exhibit C shall not be deemed to limit or define obligations of the Fire District as provided elsewhere in this Agreement, and the Fire District should rely on its expertise to obtain additional insurance coverage needed for the City and the Fire District in its performance hereunder.
- 3.9. **Charter Provision.** This Agreement is subject to the provisions of section 17.9 of the Charter for the City of Broomfield.
- 3.10. **Other Conditions.** The Fire District agrees maintain the trees and shrubs (if any) within the Temporary Use Area as follows:
 - 3.10.1. The Fire District shall provide water as needed
 - 3.10.2. The Fire District shall ensure the area around the plantings is kept free of weeds.

- 3.10.3. The Fire District shall remove the trees and plantings if they die.
- 3.10.4. The Fire District shall return the property to its original condition if trees and plantings are removed.

- 4.0 **ASSIGNMENT.** This Agreement shall not be assigned by Fire District without the prior written consent of the City, which may withhold its consent for any reason.
- 5.0 **NOTICES.** Any notice required or permitted by this Agreement shall be in writing and shall be deemed to have been sufficiently given for all purposes if personally served or if sent by certified mail or registered mail, postage and fees prepaid, addressed to the party to whom such notice is to be given at the address set forth below, or at such other addresses as have been previously furnished in writing, to the other party or parties.

City and County of Broomfield

ATTN: City Manager
Address: One DesCombes Drive
City: Broomfield
State: Colorado
Zip: 80020

North Metro Fire Rescue District

ATTN: Fire Chief Dave Ramos
Address: 101 Spader Way
City: Broomfield
State: Colorado
Zip: 80020

Such notice shall be deemed to have been given when deposited in the United States Mail.

- 6.0 **INTEGRATION AND AMENDMENT.** This Agreement represents the entire agreement between the Parties and there are no oral or collateral agreements or understandings. This Agreement may be amended only by an instrument in writing signed by the parties. If any other provision of this Agreement is held invalid or unenforceable, no other provision shall be affected by such holding, and all of the remaining provisions of this Agreement shall continue in full force and effect.
- 7.0 **COMPLIANCE WITH THE LAWS.** The Fire District shall observe and comply with all applicable laws, including but not limited to federal, state and local laws, regulations, rules or ordinances that affect this Permit and those employed or engaged by the Fire District.
- 8.0 **GOVERNING LAW.** This Agreement shall be governed by the laws of the State of Colorado. Venue for any legal action related to this Agreement shall lie in the District Court, Broomfield County, Colorado.
- 9.0 **WAIVER OF BREACH.** A waiver by any party to this Agreement of the breach of any term or provision of this Agreement shall not operate or be constructed as a waiver of any subsequent breach by either party.
- 10.0 **BINDING EFFECT.** This Agreement shall insure to the benefit or, and be binding upon, the parties, their respective legal representatives, successors, heirs, and assigns;

provided, however, that nothing in this paragraph shall be construed to permit the assignment of this Agreement except as otherwise expressly authorized herein.

- 11.0 EXHIBITS. All exhibits referred to in this Agreement are by reference incorporated herein for all purposes.
- 12.0 PARAGRAPH CAPTIONS. The captions of the paragraphs are set forth only for the convenience and reference of the parties and are not intended in any way to define, limit, or describe the scope or intent of this Agreement.
- 13.0 ADDITIONAL DOCUMENTS OR ACTION. The parties agree to execute any additional documents or take any additional action that is necessary to carry out this Agreement.
- 14.0 NO THIRD PARTY BENEFICIARIES. This Agreement is intended to describe the rights and responsibilities only as to the parties hereto. This Agreement is not intended and shall not be deemed to confer any rights on any person or entity not named as a party hereto.
- 15.0 NO PRESUMPTION. The parties to this Agreement and their attorneys have had a full opportunity to review and participate in the drafting of the final form of this Agreement. Accordingly, this Agreement shall be construed without regard to any presumption or other rule of construction against the party causing the Agreement to be drafted.
- 16.0 EXECUTION: ELECTRONIC SIGNATURES. This Agreement may be executed in counterparts, each of which shall be deemed an original and all of which shall constitute but one and the same instrument. This Agreement shall not be binding upon any Party hereto unless and until the Parties have executed this Agreement. The Parties approve the use of electronic signatures for execution of this Agreement.

[The remainder of this page is intentionally left blank.]

DATED: _____

THE CITY AND COUNTY OF BROOMFIELD,
a Colorado municipal corporation & body
politic and corporate of the State of Colorado

Mayor
One DesCombes Drive
Broomfield, CO 80020

ATTEST:

City and County Clerk

APPROVED AS TO FORM:

City and County Attorney's Office

Fire District

NORTH METRO FIRE RESCUE DISTRICT
A Colorado Corporation
101 Spader Way
Broomfield, Colorado 80020

By: 
Name: David Ramos
Its: Fire Chief

Exhibit A

Legal Description of Revocable Permit Area



EXHIBIT B

Facilities



EXHIBIT C
Insurance Requirements

CITY and COUNTY of BROOMFIELD INSURANCE REQUIREMENTS - Including GL/Auto/WC

1. All insurers must be licensed or approved to do business within the State of Colorado.
2. Contractor/Vendor's insurance carriers should have an A.M. Best Company rating of at least A- VII.
3. Additional Insured - City and County of Broomfield, its officers, board members, agents, employees and volunteers acting within the scope of their duties for the City and County of Broomfield shall be named as Additional Insured on all Commercial General Liability and Automobile Liability Insurance policies (construction contracts require Additional Insured coverage for completed operations).
4. Primacy of Coverage - Coverage required of Contractors and Subcontractors shall be primary and non-contributory to any insurance carried by the City and County of Broomfield.
5. All subcontractors must meet the same insurance requirements for the Contract or Purchase Order unless Risk Management has approved a deviation.
6. Subrogation Waiver - All insurance policies required under this Contract maintained by Contractor or its Subcontractors shall waive all rights of recovery against City and County of Broomfield, its officers, board members, agents, employees and volunteers acting within the scope of their duties for the City and County of Broomfield.
7. Cancellation - The above insurance policies shall include provisions preventing cancellation or non-renewal without at least 30 days prior notice to Contractor/Vendor and Contractor/ Vendor shall forward such notice to within seven days of receipt of such notice.
8. Certificates - Contractor and all Subcontractors shall provide certificates showing insurance coverage required hereunder to the City and County of Broomfield within 5 days of:
 - a. the effective date of the Contract
 - b. the expiration date of any coverage
 - c. a request by the City and County of Broomfield
9. City and County of Broomfield in no way warrants that the limits required herein are sufficient to protect the Contractor/Vendor from liabilities that may arise out of the performance of the work under this Contract by the Contractor, its agents, representative, employees or subcontractors. The Contractor is not relieved of any liability or other obligations assumed or pursuant to the Contract by reason of its failure to obtain or maintain insurance in sufficient amounts, duration or type.
10. All parties understand and agree that the City and County of Broomfield is relying on, and does not waive or intend to waive by any provision of this Contract, the monetary limitations, immunities, protections or any other rights provided by the Colorado Governmental Immunity Act.
11. The City and County of Broomfield reserves the right to negotiate additional specific insurance requirements at the time of the Contract.

Vendor/Contractor/Subcontractor shall obtain and maintain, at its own expense and for the duration of the contract including any warranty periods under which the Contract are satisfied, the following:

Insurance Requirements - GL/Auto/WC		
	COVERAGES AND LIMITS OF INSURANCE	Required
1	<p>Commercial General Liability</p> <ul style="list-style-type: none"> Commercial General Liability insurance covering all operations by or on behalf of the contractor/vendor on an occurrence basis against claims for bodily injury, property damage (including loss of use), advertising liability, products and completed operations, and contractual liability. <p>Note: For contracts involving vendor/contractor contact with minors or at risk adults Sexual Abuse and Misconduct Coverage should be included in the coverage requirements.</p>	<p>Minimum Limits:</p> <ul style="list-style-type: none"> \$1,000,000 Each Occurrence \$2,000,000 General Aggregate (Per project aggregate for construction contracts) \$2,000,000 Products/Completed Operations Aggregate (for construction projects, this coverage should be maintained for a minimum of 3 years from the end of the project)
2	<p>Automobile Liability</p> <ul style="list-style-type: none"> Automobile Liability Insurance covering any auto (including owned, hired and non-owned autos). 	<p>Minimum Limit:</p> <ul style="list-style-type: none"> \$1,000,000 each accident combined single limit. If hazardous materials are transported, an MCS 90 form shall be included on the policy.
3	<p>Workers' Compensation</p> <ul style="list-style-type: none"> Workers' Compensation Insurance as required by State statute, covering all Vendors/Contractors employees acting within the course and scope of their employment. Employer's Liability with: <p>Note: This requirement shall not apply when a contractor or subcontractor is exempt under the Colorado Workers' Compensation Act AND when such contractor or subcontractor provides an appropriate sole proprietor letter.</p>	<p>Employer's Liability with Minimum Limits:</p> <ul style="list-style-type: none"> \$100,000 Each Accident \$100,000 Each Employee by Disease \$500,000 Disease Aggregate
<p>Additional Insured - The following shall be named an Additional Insured: The City and County of Broomfield, its officers, board members, agents, employees and volunteers acting within the scope of their duties for the City and County of Broomfield shall be named as Additional Insured on all Commercial General Liability, Umbrella Liability and Automobile Liability Insurance policies (construction contracts require Additional Insured coverage for completed operations). A Waiver of Subrogation is provided in favor of the Additional Insureds as respects to all policies.</p> <p>Certificate Holder is: City and County of Broomfield One DesCombes Drive Broomfield, CO 80020-2495 certificates@broomfield.org</p>		

Any deviations below the standards given above must be approved by the City and County of Broomfield's Risk Management office. Please direct any questions to RiskManagement@broomfield.org

Signature: 
Email: dramos@northmetrofire.org



CERTIFICATE OF COVERAGE

Certificate Number CERT-008236

ADMINISTRATOR Colorado Special Districts Property and Liability Pool c/o McGriff Insurance Services, LLC PO Box 1539 Portland, OR 97207-1539	THIS CERTIFICATE IS ISSUED AS A MATTER OF INFORMATION ONLY AND CONFERS NO RIGHTS UPON THE CERTIFICATE HOLDER. THIS CERTIFICATE DOES NOT AMEND, EXTEND OR ALTER THE COVERAGE AFFORDED BY THE POLICIES BELOW.
NAMED MEMBER North Metro Fire Rescue District 101 Spader Way Broomfield, CO 80020	COMPANIES AFFORDING COVERAGE COMPANY A: Colorado Special Districts Property and Liability Pool COMPANY B: COMPANY C: COMPANY D:

COVERAGES

THIS IS TO CERTIFY THAT COVERAGE DOCUMENTS LISTED HEREIN HAVE BEEN ISSUED TO THE NAMED MEMBER HEREIN FOR THE COVERAGE PERIOD INDICATED. NOTWITHSTANDING ANY REQUIREMENT, TERM OR CONDITION OF ANY CONTRACT OR OTHER DOCUMENT WITH RESPECT TO WHICH THIS CERTIFICATE MAY BE ISSUED OR MAY PERTAIN, THE COVERAGE AFFORDED BY THE COVERAGE DOCUMENTS LISTED HEREIN IS SUBJECT TO ALL THE TERMS, EXCLUSIONS AND CONDITIONS OF SUCH COVERAGE DOCUMENTS.

CO LTR	Type of Coverage	Coverage #	Effective Date	Expiration Date	LIMITS	
A	General Liability	24PL-52004-3224	01/01/24	12/31/24	General Aggregate	Unlimited
	<input checked="" type="checkbox"/> Commercial General Liability <input checked="" type="checkbox"/> Public Officials Liability <input checked="" type="checkbox"/> Employment Practices <input checked="" type="checkbox"/> Occurrence	*Except that for claims, occurrences or suits to which the monetary limits of the Colorado Immunity Act, C.R.S. & 24-10-101, et.seq., as amended, apply, there shall be a further sublimit of (a) \$424,000 for an injury to any one person in any single occurrence; and (b) \$1,195,000 for an injury to two or more persons in any single occurrence; but in the event of an injury to two or more persons in any single occurrence, the sublimit shall not exceed \$424,000 for each injured person.		Each Occurrence*	\$2,000,000	
A	Automobile Liability <input checked="" type="checkbox"/> Scheduled Autos <input checked="" type="checkbox"/> Hired Autos <input checked="" type="checkbox"/> Non-Owned Autos	24PL-52004-3224	01/01/24	12/31/24	Each Occurrence*	\$2,000,000
	Auto Physical Damage <input type="checkbox"/> Scheduled Autos <input type="checkbox"/> Hired Autos					
	Excess Liability <input type="checkbox"/> Other Than Umbrella Form				General Aggregate	
					Each Occurrence*	
	Property <input type="checkbox"/>					

Description:
 The City and County of Broomfield, its officers, board members, agents, employees and volunteers acting within the scope of their duties for the City and County of Broomfield are listed as Additional Covered Members under General Liability and Excess Liability only, which shall apply on a primary non-contributory basis, as required under contract. Only those liabilities covered by the Pool's coverage document for the Member District shall apply, subject to the provisions and limitations contained in the Colorado Governmental Immunity Act C.R.S. 24-10-101, as amended. A Waiver of Subrogation in favor of the City and County of Broomfield shall apply under the General Liability and Excess Liability as required under contract. Should any of the described policies be cancelled before the expiration date thereof, 30 days' notice shall be delivered in accordance with the policy's cancellation provision. The Colorado Special Districts Property and Liability Pool has been assigned a Financial Stability Rating® (FSR) of AAA, Unsurpassed by Demotech, Inc.

CERTIFICATE HOLDER	CANCELLATION
	SHOULD ANY OF THE ABOVE DESCRIBED COVERAGES BE CANCELLED BEFORE THE EXPIRATION DATE THEREOF, NOTICE WILL BE DELIVERED IN ACCORDANCE WITH THE COVERAGE FORM PROVISIONS.

City and County of Broomfield
One DesCombes Drive
Broomfield, CO 80020

AUTHORIZED REPRESENTATIVE:
By: Joseph E. DePaepe

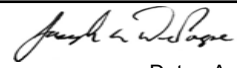

Date: August 12, 2024



City of Broomfield

City Council Regular Meeting

Proposed Resolution for Detention Center Boiler Replacement

Meeting	Agenda Group
Tuesday, September 10, 2024, 6:00 PM	Consent Items Item: 6E
Presented By	
Ken Rutt, Director of Public Works	
Community Goals	
<input checked="" type="checkbox"/> Financial Sustainability and Resilience	

Overview

[View Correspondence](#)

The Facility Services Division of the Public Works Department manages the heating, ventilation, and air conditioning (HVAC) systems for Broomfield facilities and buildings. The replacement of heating and cooling equipment is based on a number of factors including repair costs, years in service, availability of repair parts, overall physical condition, efficiency, and reliability.

The existing boiler at the Detention and Training Center (Detention) is in need of replacement. This unit is over 22 years old, installed when the Detention Center was constructed in 2001. This exceeds the manufacturer's estimated life expectancy of 15 years. Proposed Resolution No. 2024-47 would authorize and approve an agreement with Design Mechanical Inc. in the amount of \$453,233.

Attachments

[Memo for Detention Center Boiler Replacement.pdf](#)

[Resolution No. 2024-47 \(1\).pdf](#)

[Design Mechanical Inc - Construction Agreement - Detention Center Boiler Replacement \(vendor signed\).pdf](#)

MemoSummary

[View Correspondence](#)

The Facility Services Division of the Public Works Department manages the heating, ventilation, and air conditioning (HVAC) systems for Broomfield facilities and buildings. The replacement of heating and cooling equipment is based on a number of factors including repair costs, years in service, availability of repair parts, overall physical condition, efficiency, and reliability.

This project focuses on replacement of the Domestic and Hydronic Hot Water System at the Detention Center. The system currently has three Hydronic Boilers for sensible heating in the building and four Domestic Hot Water Heaters, half supplying the original building and half supplying the building addition (2009). The current boilers were rated at 85% efficiency 22+ years ago, installed when the Detention Center was constructed in 2001. They have exceeded the manufacturer's estimated life expectancy of 15 years and repair parts are limited as the boiler units are nearly obsolete.

The existing system will be replaced with 2 new condensing boilers with dual returns that allow for a customized system that maximizes operation efficiencies and supplies the entire building with added redundancy to better support the facility. The new system enhances boiler efficiency up to an additional 13% which allows lower operating supply temperatures and superior 98% energy efficiency and reliability. The new tankless hot water system works in an "on-demand" theory, meaning less stored water when the system is not in use (in sinks, showers, appliances etc).

This replacement project aligns with the City's Greenhouse Gas reduction targets by reducing the carbon footprint of the building by upwards of 26%.

The new Hydronic and Domestic boiler system will drastically reduce natural gas input from 7.9 MMBtu (Million British Thermal units) to 2.2 MMBtu. Currently Xcel Energy is \$.497 a MMBtu resulting in a charge of \$3.926 per hour. The new equipment and system is anticipated to cost \$1.093 per hour.

In September 2022, staff prepared and published an Invitation for Bid (#22-092222) on the Rocky Mountain E-Purchasing System (BidNet). At that time, no bids were received due to supply chain issues and the vendors inability to hold pricing for the long lead times on equipment.

On May 3, 2024, staff again prepared and published an Invitation for Bid (#24-IFB-PW-007)) on the BidNet. This proposal included the replacement of the existing 2.0 MMBtu natural gas heater water boiler with a high efficiency condensing boiler as well as associated hydronic circulating pumps, and variable frequency drives. Again, no bids were received.

With a recommendation from the Procurement Division, staff reached out to five vendors to obtain documented quotes. The bids ranged from \$453,233 to \$902,464. Design Mechanical Inc. had the lowest price and was highly responsive during the process.

Proposed Resolution No. 2024-47 would authorize and approve an agreement with Design Mechanical Inc. in the amount of \$453,233. The agreement covers labor, materials, and supplies for the installation of a high efficiency boiler at the Detention and Training Center. Proposed Resolution No. 2024-47 would also authorize the City and County Manager to approve change orders not to exceed \$45,324.

Financial Considerations

As shown in the sources and uses of funds summary below, the project can be completed within the budgeted amount.

Sources and Uses of Funds	Amount
Fund 1 20-70011-55200 22R022	\$673,235
Engineering Services	
	-\$21,600
Design Mechanical Inc	
	-\$453,233
Contingency (10%)	
	-\$45,324
Projected Balance	\$153,078

Prior Council or Other Entity Actions

Council adopted [Resolution No. 2023-134](#) approving the budget for fiscal year 2024, which included requested CIP projects.

Boards and Commissions Prior Actions and Recommendations

N/A

Proposed Actions / Recommendations

If Council desires to approve the contract, the appropriate motion is...
That Resolution 2024-47 be adopted.

Alternatives

Do not proceed with the contract at this time.

RESOLUTION NO. 2024-47

A resolution approving an agreement with Design Mechanical Inc. to replace the boiler at the Detention Center.

Be it resolved by the City Council of the City and County of Broomfield, Colorado:

Section 1.

The agreement by and between the City and County of Broomfield and Design Mechanical Inc. attached hereto, in amount not to exceed \$498,557 to replace the boiler at the Detention Center, is approved.

Section 2.

The Mayor or Mayor Pro Tem is authorized to sign and the Office of the City and County Clerk to attest the agreement, in form approved by the City and County Attorney.

Section 3.

The City and County Manager or a designee is authorized to approve change orders annually in aggregate amounts up to ten percent of the then current contract amount.

Section 4.

This resolution is effective upon its approval by the City Council.

Approved on September 10, 2024

The City and County of Broomfield, Colorado

Mayor

Attest:

Office of the City and County Clerk

Approved as to form:

NCR

City and County Attorney

A CONSTRUCTION AGREEMENT BY AND BETWEEN THE CITY AND COUNTY OF BROOMFIELD AND
DESIGN MECHANICAL INCORPORATED FOR THE DETENTION CENTER BOILER REPLACEMENT
PROJECT

1. PARTIES. The parties to this Construction Agreement (this "Agreement") are the City and County of Broomfield, a Colorado municipal corporation and county, (the "City") and Design Mechanical Incorporated, a Colorado corporation (the "Contractor"), collectively, the "Parties," or individually, a "Party."
2. RECITALS. The Recitals to this Agreement are incorporated herein by this reference as though fully set forth within the body of this Agreement.
 - 2.1. The City is seeking construction services for the replacement of the domestic hot water and hydronic boiler system at the Broomfield Detention Center located at 11600 Ridge Pkwy, Broomfield, CO 80021 and completed a competitive selection process by Invitation for Bid # 24-IFB-PW-007 ("IFB").
 - 2.2. The Contractor's response to the above referenced IFB was determined to be of best value, responsible, responsive bidder to the City for the procurement of the services requested.
 - 2.3. The Parties therefore desire to enter into this Agreement for completion of the services further described herein.
3. TERMS AND CONDITIONS. In consideration of the mutual covenants and promises of the Parties contained herein, and other valuable consideration, the receipt and adequacy of which are hereby acknowledged, the Parties agree as follows:
 - 3.1. Work. The Contractor agrees to furnish all necessary labor, materials, equipment, tools, and services necessary to perform in a workmanlike manner the work described in the Project Plans and Specifications and Project Narrative attached hereto as Exhibits A and B and incorporated by this reference (the "Work" which includes the Phase 1 Work and the Phase 2 Work as defined in this paragraph). The Work shall consist of two phases: Phase 1 includes the Preconstruction Services which includes the ordering of materials for the Work and demolition and preparation of the area for the installation of the new system including the phasing of the work as described in Exhibit B to minimize the down time of the domestic hot water supply to the occupied facility (the "Phase 1 Work"). Phase 2 includes the Construction Services to complete the work as described in Exhibit A and Exhibit B (the "Phase 2 Work").
 - 3.2. Contract Documents. The Contract Documents shall consist of the following:
 - 3.2.1. This Agreement; and
 - 3.2.2. The Project Plans and Specifications attached hereto as Exhibit A;

- 3.2.3. The Project Narrative attached hereto as Exhibit B;
- 3.2.4. The Contractor's Cost Proposal dated August 1st, 2024, attached hereto as Exhibit C; and
- 3.2.5. The IFB; and
- 3.2.6. Any change orders and contract amendments, as applicable; and
- 3.2.7. The Insurance Requirements attached hereto as Exhibit D,

all of which are incorporated by reference as though set forth in full herein, whether or not attached hereto and shall form an integral part of this Contract. If there is any conflict between this Agreement and the other Contract Documents, this Agreement shall control.

- 3.3. Access and Inspection. The City and its representatives shall at all times have access to the Work. The Contractor shall provide proper facilities for access to and for inspection of the Work for the purpose of determining compliance with this Agreement and quality of workmanship and material. All materials, equipment and supplies used in the performance of the Work shall be subject to adequate inspection and testing in accordance with generally accepted standards. The City Representative may order that portions of the Work be uncovered, exposed or made available for observation, inspection or testing at no additional cost. The Contractor shall provide all labor, tools, materials, equipment and supplies necessary to comply with the request of the City Representative. If any portion of the Work is determined to be defective, the Contractor shall bear all costs involved to bring the Work into compliance with the Agreement, including without limitation the cost to replace any materials, to re-perform or to reconstruct. The Contractor shall remove from the work site all work or materials rejected by the City for failure to comply with the Contract whether incorporated in the Work or not at no additional cost to the City.
- 3.4. Site Clean-Up. On a daily basis, the Contractor shall maintain the work site free from accumulation of waste materials or rubbish caused by performance of the Work. The Contractor shall remove all rubbish, tools, construction equipment, machinery, and surplus material from the work site. If the Contractor fails to maintain the work site in an appropriate condition, the City may, after notice to the Contractor, perform any necessary clean-up and charge the clean-up costs to the Contractor.
- 3.5. Protection of Property. All existing finishes, structures, utilities, services, roads, trees, shrubbery, etc. located on City property and adjacent property impacted by the Work shall be protected against damage or interrupted services at all times by the Contractor during the term of the Work. The Contractor shall be responsible for repairing or replacing any and all property which is damaged by reason of the Contractor's operation on the property to

the satisfaction of the City within three (3) weeks of the notification of such damage, which may be extended with written approval of the City.

- 3.6. Utilities. The Contractor shall fully comply with the provisions of Article 1.5 of Title 9 of the Colorado Revised Statutes including, but not limited to, providing notices to the notification association. Unless otherwise provided in the Scope of Work, the Contractor shall be responsible for communicating and coordinating with utilities, as necessary. The Contractor shall cooperate with utilities and the City as provided in this Agreement and as required by law. The Contractor shall be responsible for determining the exact location of utilities that may interfere with construction of the Work by exploratory excavation sufficiently in advance of beginning construction in an area so that potential conflicts may be resolved. The Contractor will consider in the Contract Price all of the utility appurtenances within the project; and the Contractor shall not make a claim for delay or additional compensation due to any relocation operations by a utility.
- 3.7. Secure Areas. For Work performed in secured areas as determined by the City, the Contractor shall work with the City to develop a procedure to sign all workers in and out, and inventory all tools and equipment used in the Work. No later than two weeks prior to the start of the Work all workers will be required to provide the City with information required to perform security background checks. The City will approve all workers after a review of the security background checks and criminal histories and will have the right to reject any worker based on the worker's criminal history. Any changes in personnel during the project shall be subject to the security background check review and approval requirements contained herein prior to accessing the facility. Continuous surveillance of the Work may be provided by the City.
- 3.8. Security and On-Site Procedures. At the option of the City, all on-site personnel utilized by the Contractor shall undergo background checks and will be issued Contractor badges. Personnel utilized by the Contractor shall be required to display badges at all times while working on-site. The Contractor shall be required to return to the City project manager all badges issued to the Contractor, its employees and agents, within 10 days of the Outside Completion Date (the "Return Date"). If the Contractor is unable to return all issued badges on or before the Return Date, then the City will charge the Contractor fifty dollars (\$50.00) per missing badge which sum shall be deducted from any sum payable hereunder before final payment to the Contractor. The Contractor agrees to comply with all Contractor Work Schedule requirements set forth in the Agreement, as applicable.
- 3.9. Documents on Site. The Contractor shall maintain at the site for the City one electronic or hard copy of all drawings, specifications, addenda, change orders

and other modifications, in good order and marked currently to record all changes made during construction. At the City's option, the referenced record drawings will be reviewed monthly by the City for acceptability. If, in the judgment of the City, the Contractor fails or refuses to keep these documents current, the Contractor shall not be entitled to progress payments until it makes the necessary changes to the documents to make them current.

3.10. Differing Site Conditions. The Contractor acknowledges that it has satisfied itself as to the character, quality, and quantity of surface and subsurface materials or obstacles to be encountered insofar as this information is reasonably ascertainable from an inspection of the site and review of the Contract Documents.

3.10.1. Contractor shall give immediate written notice to the City Representative if it encounters a "Differing Site Condition," defined as either:

3.10.1.1. Subsurface or latent physical conditions at the site which differ materially from those indicated in the Contract Documents; or

3.10.1.2. Unknown physical conditions at the site, of an unusual nature, which differ materially from those ordinarily encountered and generally recognized as inhering in work of the character provided for in this Contract.

3.10.2. Contractor acknowledges that no request for a change order or modification in Contract Price resulting from a Differing Site Condition shall be allowed unless immediate written notice is provided and the conditions remain undisturbed until the City has the opportunity to investigate.

4. Completion Date. Within ten (10) calendar days of receipt of executed Agreement, the Contractor shall provide the City acceptable bonds and certificates of insurance. A Notice to Proceed for the Phase 1 work will be issued upon City approval of the bonding and insurance. The Contractor shall perform no Work until the City Representative issues a Notice to Proceed for the Phase 1 Work.

The Contractor shall begin the Phase 1 Work on or before the fifth (5th) calendar day after receipt of the notice to proceed for the Phase 1 Work ("Phase 1 Notice to Proceed"). The Phase 1 Notice to Proceed for the Phase 1 Work will stipulate the date on which the contract time count commences for the Phase 1 Work (the "Phase 1 Start Date"). The Contractor shall complete the Phase 1 Work and fulfill all of its other obligations for Phase 1 as quickly as possible, with the understanding that the lead time for ordering the equipment will constitute the majority of the time in Phase 1.

The Contractor shall send written notice to the City Representative that the Phase 1 Work is complete and the Contractor has received the materials to begin the Phase 2 Work (the "Phase 1 Completion Notice").

Within five (5) working days of receipt of the Phase 1 Completion Notice, the City Representative shall issue a notice to proceed for the Phase 2 Work (the "Phase 2 Notice to Proceed"). The Contractor shall perform no Phase 2 Work until the City issues a Phase 2 Notice to Proceed. The Contractor shall begin the Phase 2 Work on or before the fifth (5th) calendar day after receipt of the Phase 2 Notice to Proceed. The Phase 2 Notice to Proceed for the Phase 2 Work will stipulate the date on which the contract time count commences for the Phase 2 Work (the "Phase 2 Start Date"). The Contractor shall complete the Phase 2 Work and fulfill all of its other obligations for Phase 2 within ninety (90) calendar days of the Phase 2 Start Date (the "Phase 2 Completion Date"). The time between the Phase 2 Start Date and the Phase 2 Completion Date shall be known as the Phase 2 Contract Time. The Phase 1 and Phase 2 Contract Time together shall be referred to as the ("Contract Time"), provided that in no event shall the completion time for the Work extend later than December 20, 2024 (the "Outside Completion Date"). All time limits are of the essence in this Agreement.

5. CONTRACTOR'S PROJECT SCHEDULE. The Contractor shall submit a completion schedule for the Work (the "Project Schedule") beginning with receipt of the signed Agreement and concluding with Project Completion prior to the commencement of the Work and shall coordinate on a daily basis with the City's project manager. The Project Schedule shall include all lead time for the order and delivery of equipment for the Work. Schedule updating shall be done on a weekly basis, or more often as necessary (each a "Schedule Update"). The revision shall indicate actual progress to date, changes resulting from change orders, and planned changes as necessary to complete the Work in accordance with the Contract Documents. All costs associated with the development and maintenance of the Project Schedule shall be borne by the Contractor. Acceptance by the City of the Contractor's Project Schedule does not relieve the Contractor of any of its responsibility whatsoever for the accuracy or feasibility of the Project Schedule, or of the Contractor's ability to meet the Contract Time, nor does such acceptance expressly or impliedly warrant, acknowledge or admit the reasonableness of the activities, duration, or cost loading of the Contractor's Project Schedule.
6. PRICE AND PAYMENT. The City shall pay the Contractor for performance of the Work an amount not to exceed \$453,233.00 (the "Contract Price") based upon the unit prices set forth on Contractor's Cost Proposal attached hereto as Exhibit C and in accordance with the following schedule:

- 6.1. If the Contractor is satisfactorily performing the Agreement, the City shall make partial payments at the end of each calendar month or as soon thereafter as practicable of ninety-five percent (95%) of the Contract Price based on the calculated value of the Work completed (the "Partial Payments") and shall retain five percent (5%) of the amount due to the Contractor (the "Retained Amount") until the Work is complete. If applicable, the Contractor shall make payments to its subcontractors in accordance with C.R.S. §24-91-103.
- 6.2. The City shall retain the Retained Amount until Final Acceptance (as defined in Final Acceptance and Final Payment below). If the Contractor has completed the Work in a manner finally acceptable to the City, the City may authorize final payment from the Retained Amount upon written request by invoice of the Contractor (the "Final Payment"). Before the Final Payment is made, the City and the Contractor, as applicable, shall comply with the Final Acceptance and Payment paragraph of this Agreement.
- 6.3. The Contractor shall, as soon as practicable after the end of each calendar month during performance of the Work, submit an itemized invoice for services performed, stating the percentage of the Work that has been completed and the type of services performed. Each invoice will also include an Application and Certificate of Payment form (AIA Document G702) or equivalent form approved by the City. The Contractor shall prepare the invoices at its sole cost and shall include sufficient detail to enable the City to verify the appropriateness of the invoice. Each invoice shall be subject to review and approval by the City Representative. The City shall not be required to pay disputed items until the dispute is resolved. Payment of any invoice shall not act as a waiver of the City's right to recover in full any over-payment revealed by any subsequent audit or inspection. No air travel, car rental, entertainment, education expense, meals or similar or related costs shall be payable without prior written approval of the City. Incorrect payments to the Contractor due to omission, error, fraud, or defalcation may be recovered from the Contractor by deduction from subsequent payments due the Contractor under this Contract or other contracts between City and Contractor.
- 6.4. Change Orders. The Contractor will do nothing to cause the Contract Price to increase without prior execution of a change order by the City. The City will issue no change order requiring additional compensable work to be performed, which work causes the aggregate amount payable under this Agreement to exceed the amount appropriated for this Agreement. Except as provided below and as provided in C.R.S. 24-91-103.6, the City shall have no duty or obligation whatsoever to compensate or to reimburse the Contractor for any additional work not specifically authorized as provided herein. In the event (i) the City requires additional compensable work to be performed by the Contractor prior

to the execution or other finalization of a change order or contract amendment, and (ii) the Contractor has submitted to the City an estimate of the cost for the additional compensable work, then the City shall reimburse the Contractor for the costs associated with such additional work on a periodic basis in accordance with the terms of this Agreement.

7. FINAL INSPECTION AND FINAL PAYMENT.

7.1. Final Inspection. The Contractor shall notify the City when the Work is complete and ready for final inspection by means of a letter of completion (the "Letter of Completion"). Within ten (10) calendar days of the City's receipt of the Letter of Completion, the City Representative shall make a final inspection to determine whether the Work has been completed in accordance with this Agreement and shall submit a written list of any defects to the Contractor (the "Punch List"). The Contractor shall promptly correct all Punch List items without additional cost to the City within ten (10) calendar days after receipt of the Punchlist. If any Punchlist item cannot be corrected within ten (10) calendar days, the Contractor shall submit a letter to the City Representative for approval requesting an extension of time to complete such item (the "Request for Extension"). The Request for Extension must be received by the City Representative within seven (7) calendar days of the Contractor's receipt of the Punchlist and shall include the Contractor's justification for the request and a schedule for completion of the Punchlist item. The Contractor shall also deliver to the City, all statements to support state sales and use tax refunds and any as-built drawings. The Contractor shall provide the City with a letter of approval for contract closure from any surety furnishing bonds for the Work provided on AIA Form G707 (Consent of Surety Letter) or equivalent form.

7.2. Final Payment. Upon satisfactory completion of the Work, the City Representative will provide the Contractor with a written acceptance of the Work (the "Final Acceptance"). Payment shall not be made until the City Representative has approved the payment and a notice of contractor's settlement has been published in accordance with C.R.S. §38-26-107. The City shall condition publication and final settlement upon receipt of any duly executed approvals of the corporate surety or sureties issuing the bonds required hereunder. Such final settlement shall be advertised as provided by statute at least twice, the last publication appearing at least ten (10) days prior to the date of final settlement. On the date of final settlement (or such later date as may be permitted by statute if claims are asserted or litigation is commenced alleging nonpayment of funds due for labor, materials, supplies, etc.), payment and final settlement shall be made in full.

8. CONTRACTOR'S REPRESENTATIONS. In order to induce the City to enter into this Agreement, the Contractor makes the following representations:

8.1. The Contractor has familiarized itself with the nature and extent of the Agreement, Work, the locality, and with all local conditions and federal, state and local laws, ordinances, rules and regulations that in any manner may affect cost, progress or performance of the Work. The Contractor acknowledges an obligation to comply with all applicable laws, including the Broomfield Municipal Code, to respect property rights by working within the defined work limits or designated staging areas, and to work within the prescribed work hours. The Contractor acknowledges that use of air compression brakes ("jake brakes") within City limits is prohibited, unless otherwise posted by the City Traffic Engineer.

8.2. Before submitting a proposal, the Contractor has become fully informed regarding the Work and any materials or equipment required, including the amount or quantity thereof. No adjustment or modification shall be allowed for any misunderstanding of the Work or of equipment or material requirements, or of the provisions contained in this Contract and in the other Contract Documents.

8.3. Contractor has given the City written notice of any conflicts, errors or discrepancies that he has discovered in the Agreement and exhibits incorporated therein and the written resolution thereof by the City is acceptable to the Contractor.

9. NOTICE AND AUTHORIZED REPRESENTATIVES. Any notice required or permitted by this Agreement shall be in writing and shall be sufficiently given for all purposes if sent by email to the authorized representative identified below. Such notice shall be deemed to have been given when the email was sent and received. The City may change its representative at any time by notice to the Contractor. The Contractor shall not replace the Contractor Representative unless: (a) the City requests a replacement, or (b) the Contractor terminates the employment of the Contractor Representative and provides a satisfactory substitute. The City must approve a substitute Contractor Representative, and, if no substitute is acceptable, the City may terminate this Agreement. The Parties each designate an authorized representative as follows:

5.1 The City designates the Facility Division Superintendent as the authorized representative of the City under this Agreement. Email address is jjohnson@broomfield.org

5.2 The Contractor designates Mike Van Allen as the authorized representative of the Contractor under this Agreement. Email address is Mike.vanallen@csusa.us

If the Contractor is alleging that the City is in breach of this Agreement or has violated

any term of this Agreement, Legal Notice shall be made by making the notice above with a copy to citycountyattorney@broomfield.org.

Failure of City's on-site representative to call to the attention of the Contractor any defective work or deviations from the Contract Documents shall not constitute acceptance of such work by the City or relieve the Contractor of its obligation to perform the Work in strict accordance with the Contract Documents.

10. TIME EXTENSIONS AND COMPENSATION FOR DELAY.

- 10.1. Remedy. If the Contractor is delayed or disrupted in the performance of the Work, the Contractor's exclusive remedy with respect to such delay or disruption shall be as stated in this Section.
- 10.2. Time Extensions. Evaluation of all time extension requests shall be based upon the latest updated project schedule submitted to the City by the Contractor.
- 10.3. Definitions. The following words shall have the meaning set forth below:
 - 10.3.1. "Contractor Delay" is defined as delay on a particular date resulting from acts or omissions within the control of the Contractor or its subcontractors, agents or suppliers, including any delay within their joint control.
 - 10.3.2. "No-Fault Delay" is defined as delay on a particular date resulting from events beyond the reasonable control of and without the fault or negligence of either the Contractor or the City or their agents, employees, contractors, subcontractors, sub-subcontractors or suppliers.
 - 10.3.3. "Owner Delay" is defined as delay on a particular date resulting from acts or omissions within the control of the City, its agents, employees or contractors, including the City's Representative.
 - 10.3.4. "Concurrent Delay" is defined as the occurrence on a particular date of one or more instances of Owner Delay and Contractor Delay, Owner Delay and No-Fault Delay or Contractor Delay and No-Fault Delay.
- 10.4. Completion Date Adjustment. An adjustment in any Completion Date for delay on a particular date shall be made under this subparagraph if any delay on such date is classified as either Owner, No-Fault or Concurrent Delay. The adjustment in any Completion Date shall only be in proportion to the amount of the delay, which is attributable to Owner, or No-Fault Delay. No adjustment in any Completion Date shall be allowed for the portion of the delay that is

attributable to Contractor Delay, including but not limited to, that portion of a Concurrent Delay which includes Contractor Delay.

- 10.5. Price Adjustment. An adjustment in the Contract Price for delay on a particular date shall be made under this subparagraph only if such delay is classified as either Owner Delay or Concurrent Delay when such Concurrent Delay includes Owner Delay. The adjustment in the Contract Price shall only be in proportion to the portion of the delay costs, which is directly attributable to Owner Delay. No adjustment in the Contract Price shall be made for the portion of the delay costs, which is attributable to Contractor Delay, or No-Fault Delay, or that portion of a Concurrent Delay which includes Contractor Delay or No-Fault Delay or both.
- 10.6. Mitigation. An adjustment in Contract Price shall be made under this subparagraph only to the extent to which the Contractor can demonstrate that its time-related costs to complete the Work will be increased. The Contractor expressly acknowledges its obligation to minimize the cost impact of compensable delays. The Contractor shall, to the best of its ability, re-assign labor and equipment, commence unaffected portions of the Work, and otherwise minimize delay costs. In no event shall the City be liable for payment of delay costs, which could have been avoided or mitigated by any means reasonably available to the Contractor or for consequential damages.
- 10.7. Notification of Delay and Recovery. The Contractor shall notify the City as soon as practicable regarding the nature and starting date of a delay, and the activities affected, but in no case later than seven (7) calendar days after the event giving rise to the delay. In the case of a continuing delay, only one notification shall be necessary. Any claim for an extension of time for delay shall be made in writing to the City not more than ten (10) calendar days after the end of the delay; otherwise, such claim shall be waived. Recovery of delay costs shall be waived unless a request for a change order for delay costs is submitted within ten (10) calendar days after the end of the delay period. The Contractor must also provide a cost and time impact analysis with any request for a change order for delay costs. The cost impact analysis shall contain all direct and indirect labor costs, all material and equipment expenses, any and all documented impact costs related to, and/or occasioned by the Work described therein, as well as all taxes (if applicable under the provisions of this Contract), insurance and profit. Documentation supporting this cost impact analysis must be submitted at the time of the request for change order for delay costs.
11. DEFAULT AND DAMAGES. If the Contractor fails to comply with any provision of this Agreement, the Contractor shall be liable for any and all damages, including without limitation, the cost of procuring similar supplies and services and all other costs and

expenses incurred by the City because of such failure. If the Contractor fails or refuses to perform the Work on schedule, or to complete the Work in a timely and satisfactory manner, the City may terminate this Contract and the Contractor's right to proceed hereunder. If the City terminates this Contract under this paragraph, the Contractor may, at the option of the City, be required to cease any or all Work provided for under this Contract and shall be liable for any additional cost to the City for services acceptable to the City from another contractor as well as any actual damages associated with such failure to perform. The cost to complete the Work or any portion thereof which remains unperformed at the time of such termination, together with any other damages, shall be deducted from any sum payable hereunder before final payment to the Contractor.

12. LIQUIDATED DAMAGES. Time is of the essence in completing the Work. Alternatively, and in lieu of actual damages for delay, in the event of delay in the completion of the Work as specified beyond the Phase 2 Completion Date or the Outside Completion Date, it would be difficult to determine the exact amount of the loss or damages suffered by the City due to delays in completion of the Work. However, the City has attempted to forecast a reasonable daily amount as compensation for the damages incurred due to late completion caused by the Contractor, based upon considerations which include, but are not limited to, public inconvenience and additional contract administration costs. Therefore, the Contractor will be liable to the City, as liquidated damages (and not as a penalty), in the amount of \$1,500 for each and every calendar day beyond the Phase 2 Completion Date or the Outside Completion Date. The City reserves the right to deduct said liquidated damages from any amount due the Contractor under this Agreement or, at its option, to collect such liquidated damages directly from the Contractor or its surety.
13. PERFORMANCE AND PAYMENT BONDS. In accordance with C.R.S. §38-26-105, if the Contract Price exceeds \$50,000, the Contractor shall furnish at its expense a separate performance bond and labor and materials bond, each for an amount not less than one hundred percent (100%) of the Contract Price. The bonds shall be issued by a qualified corporate surety licensed to transact business in Colorado. If at any time during performance of the Work the surety on the bonds shall be disqualified from doing business in Colorado, or shall become insolvent or otherwise impaired, the Contractor shall furnish bonds from an alternate surety acceptable to the City. The bonds shall remain in effect through Final Acceptance, and continuing in effect through completion of all warranty and guaranty work and shall be delivered to the City prior to the commencement of the Work. The Contractor shall secure an increase in the bonds in an amount equal to the cost of any additional work authorized pursuant to a duly executed change order or contract amendment.
14. COLORADO LABOR. If the Contract Price exceed \$500,000, the Contractor shall employ not less than eighty percent of Colorado labor of each type or class of labor in the

several classifications of skilled and common labor to perform the work under this Agreement in accordance with the provisions of C.R.S. §8-17-101 et seq.

15. **INDEPENDENT CONTRACTOR.** The Contractor is an independent contractor as provided in C.R.S. § 8-40-202(2). The Contractor is not entitled to workers' compensation benefits and the Contractor is obligated to pay federal and state income tax on monies earned pursuant to this Agreement.
16. **INDEMNIFICATION.** The Contractor expressly agrees to indemnify, defend and hold harmless the City, its officers, employees and insurers from and against all claims, damages, losses, expenses and demands, including court costs, attorney's fees and expenses, due to injuries, losses or damages arising out of, resulting from, or in any manner connected with the Contractor, its officers, employees, subcontractors or agents in connection with the performance of the services pursuant to this Agreement. Except for workers' compensation, disability benefits or other similar employee benefit claims, Contractor is not obligated to indemnify the City hereunder for that portion of any claims, damages, losses, demands, and expenses arising out of or resulting from any negligent act or omission of the City, or its agents and employees. This indemnification is intended to comply with and be subject to C.R.S. 13-50.5-102(8), as amended from time to time. In the event that any such suit or action is brought against the City, the City will give timely notice thereof to the other Party.
17. **INSURANCE.** To assure the City that the Contractor is always capable of fulfilling specified indemnification obligations, the Contractor shall purchase and maintain insurance of the kind and in the amounts required by the City, from an insurer with an AM Best FSR rating of A- or higher as more particularly set forth on Exhibit D. Current proof of such insurance is attached at Exhibit D, incorporated by this reference. However, proof of insurance attached as Exhibit D shall not be deemed to limit or define obligations of Contractor as provided elsewhere in this Agreement, and Contractor should rely on its expertise to obtain additional insurance coverage needed for the City and Contractor in its performance hereunder.
18. **APPROVAL OF SUBCONTRACTORS AND CONSULTANTS.** The Contractor shall not employ any subcontractors or consultants without the prior written approval of the City Representative. Prior to commencing any work, each subcontractor or consultant shall provide the appropriate insurance as required for the Contractor under this Agreement. The Contractor shall be responsible for coordination of the work and the acts and omissions of its agents, employees, subcontractors, consultants and suppliers, and shall bind each to the terms of this Agreement so far as are applicable. This Agreement is voidable by the City if subcontracted by the Contractor without the express written consent of the City.
19. **WARRANTY.**

- 19.1. Warranty Period. The Contractor warrants that it will perform the Work in a timely, accurate and complete manner in accordance with the provisions of this Agreement. The Contractor warrants that the materials and/or workmanship will conform to the Contract Documents and that the materials used will be of good quality and new and that the Work shall be free from defects. The Contractor shall guarantee the Work against defects in workmanship and materials for a period of 2 years, commencing on the date of final acceptance of the Work by the City Representative (the “Warranty Period”). The Contractor shall also assign to the City any longer term guarantee of materials used by the Contractor as may be provided by the manufacturer. The Contractor shall promptly replace any materials or re-perform any portion of the Work found to be defective within the Warranty Period in accordance with this Agreement and without expense to the City. The time allowed for such corrective action shall be mutually agreed upon by the City and the Contractor. If the Contractor fails to proceed promptly in accordance with these guarantees, the City reserves the right to place the Contractor in default of its contractual obligations and may have the Work performed at the expense of the Contractor. This provision shall survive the completion of the Work and the termination of this Agreement. The above guarantee does not limit any claims that the City may otherwise have against the Contractor.
- 19.2. Warranty Verification. At least 60 calendar days prior to the expiration of the Warranty Period, the City Representative shall have the option to make an inspection to determine whether the Work has been completed in accordance with this Agreement and may submit a written list of any defects to the Contractor (the “Warranty Work”). In the event the City chooses this option, the Contractor shall promptly correct all Warranty Work without additional cost to the City within the Warranty Period. If any Warranty Work cannot be corrected within the Warranty Period, the Contractor shall submit a letter to the City Representative for approval requesting an extension of time to complete such item (the “Request for Extension of Warranty Work”). The Request for Extension of Warranty Work must be received by the City Representative within seven calendar days of the Contractor’s receipt of the Warranty Work and shall include the Contractor’s justification for the request and a schedule for completion of the Warranty.
20. NO THIRD PARTY BENEFICIARIES. This Agreement is intended to describe the rights and responsibilities only as to the parties hereto. This Agreement is not intended and shall not be deemed to confer any rights on any person or entity not named as a party hereto.
21. FINANCIAL OBLIGATIONS OF THE CITY. All financial obligations of the City under this Agreement are subject to appropriation, budgeting, and availability of funds to discharge such obligations. Nothing in this Agreement shall be deemed to pledge the

City's credit or faith, directly or indirectly, to the Contractor. If funds for this Agreement are not appropriated and budgeted in any year subsequent to the fiscal year of execution of this Agreement as determined by the City, this Agreement may be terminated by the City upon written notice to the Contractor. The City's fiscal year is currently the calendar year.

22. EXHIBITS. All exhibits referred to in this Agreement are by reference incorporated herein for all purposes.
23. INTEGRATION AND AMENDMENT. This Agreement represents the entire agreement between the Parties and there are no oral or collateral agreements or understandings. This Agreement may be amended only by an instrument in writing signed by the Parties. For purposes of clarity, the terms and conditions of any Contractor invoice, Contractor timesheet, or other form, including but not limited to indemnification, limitation of liability, or cancellation fees, shall be void and of no effect against the City notwithstanding any signatures on such form by a City employee. The Contractor's rights and obligations shall be solely governed by the terms and conditions of this Agreement.
24. SEVERABILITY. If any provision of this agreement as applied to either Party or to any circumstance shall be adjudged by a court to be void or unenforceable, the same shall in no way affect any other provision of this Agreement, the application of any such provision in any other circumstances, or the validity or enforceability of the Agreement as a whole.
25. ADDITIONAL DOCUMENTS OR ACTION. The parties agree to execute any additional documents or take any additional action that is necessary to carry out this Agreement.
26. MINOR CHANGES. The Parties executing this Agreement are authorized to make nonsubstantive corrections to this Agreement and attached exhibits, if any, as they consider necessary.
27. DOCUMENTS. All drawings, analyses, plans, tests, maps, surveys, electronic files and written material of any kind generated in the performance of this Agreement or developed specifically for work performed under this Agreement shall remain the sole and exclusive property of the City, and the other Party shall not provide copies of any such material to anyone without the express written consent of the City.
28. RECORDS RETENTION. The Contractor shall maintain complete and accurate records of time spent and materials used for performance of the Work, together with any invoices, time cards, or other supporting data reasonably requested. All records, data and documentation shall be retained by the Contractor for a period of not less than three (3) years after completion of the Work, and shall be subject to review, inspection and copying by the City upon reasonable notice.

29. OFFICIALS NOT TO BENEFIT. No elected or employed member of City government shall directly or indirectly be paid or receive any share or part of this Agreement or any benefit that may arise therefrom. The Contractor warrants that it has not retained any entity or person, other than a bona fide employee working solely for the Contractor, to solicit or secure this Agreement.
30. SALES TAX EXEMPTION. The Contractor and its subcontractors, consultants and suppliers will not be required to pay Colorado state sales and use taxes on property incorporated into the Work. The Contractor shall obtain a sales tax exemption permit from the State of Colorado Department of Revenue, if necessary, to obtain materials for the Work without the payment of Colorado state sales tax.
31. ASSIGNMENT. This Agreement shall not be assigned by either Party without the prior written consent of the other Party.
32. BINDING EFFECT. This Agreement shall inure to the benefit of and be binding upon the parties and their respective legal representatives, successors, heirs, and assigns, provided that nothing in this paragraph shall be construed to permit the assignment of this Agreement except as otherwise expressly authorized herein.
33. DAYS. If the day for any performance or event provided for herein is a Saturday, a Sunday, a day on which national banks are not open for the regular transactions of business, or a legal holiday pursuant to C.R.S. § 24-11-101(1), such day shall be extended until the next day on which such banks and state offices are open for the transaction of business.
34. NO PRESUMPTION. The Parties to this Agreement and their attorneys have had a full opportunity to review and participate in the drafting of the final form of this Agreement. Accordingly, this Agreement shall be construed without regard to any presumption or other rule of construction against the Party causing the Agreement to be drafted.
35. GOOD FAITH OF PARTIES. In the performance of this Agreement or in considering any requested approval, acceptance, or extension of time, the Parties agree that each will act in good faith and will not act unreasonably, arbitrarily, capriciously, or unreasonably withhold, condition, or delay any approval, acceptance, or extension of time required or requested pursuant to this Agreement.
36. WAIVER OF BREACH. This Agreement or any of its provisions may not be waived except in writing by a Party's authorized representative. A waiver by any party to this Agreement of the breach of any term or provision of this Agreement shall not operate or be construed as a waiver of any subsequent breach by either party.

37. GOVERNING LAW. This Agreement shall be governed by the laws of the State of Colorado. Any claims or litigation arising under this Agreement will be brought by the Parties solely in the District Court, Broomfield County, Colorado.
38. LAWS TO BE OBSERVED. The Contractor shall be cognizant of all federal and state laws and local ordinances and regulations that in any manner affect those engaged or employed in the work or which in any manner affect the conduct of the work, and of all such orders and decrees of bodies or tribunals having any jurisdiction or authority over the same, and shall at all times observe and comply with all such existing laws, ordinances, regulations and decrees, and shall protect and indemnify the City against any claim or liability arising from or based on the violations of any such law, ordinance, regulation, order or decree, whether by itself, its subcontractors, agents or employees. The Contractor shall procure all necessary approvals, licenses and permits at its own expense; provided, that, the Contractor will be able to receive no cost permits when such permits are issued by the City directly.
39. TERMINATION. The City reserves the right to terminate this Contract, in whole or in part, with or without cause by written notice to the Contractor. In the event of termination, the Contractor shall incur no additional expenses and shall perform no further Work for the City under this Agreement after the date of receipt of the notice of termination, unless otherwise specified by the City. The City shall pay the Contractor for all work satisfactorily performed prior to receipt of the notice of termination and for other services required by the City to be completed prior to termination and satisfactorily performed.
40. SURVIVAL OF OBLIGATIONS. Notwithstanding anything to the contrary, the Parties understand and agree that all terms and conditions of this Agreement that require continued performance or compliance beyond the termination or expiration of this Agreement, including without limitation the indemnification provision, shall survive such termination or expiration and shall be enforceable against a Party if such Party fails to perform or comply with such term or condition.
41. DIGITAL ACCESSIBILITY STANDARDS. In 2021, the State of Colorado adopted HB21-1110 relating to the digital accessibility standards required to be implemented under the Colorado Anti-Discrimination Act which makes it unlawful to discriminate against individuals with a disability. In order to comply with the law on or before July 1, 2024, the Contractor shall ensure that all digital deliverables and digital technology provided pursuant to the terms of this Agreement shall comply with at least the Web Content Accessibility Guidelines (WCAG) 2.1 Level AA, or such updated standard as the Colorado Governor's Office of Information Technology may adopt from time-to-time.
42. EXECUTION; ELECTRONIC SIGNATURES. This Agreement may be executed in counterparts, each of which shall be deemed an original and all of which shall constitute but one and the same instrument. This Agreement shall not be binding upon

any Party hereto unless and until the Parties have executed this Agreement. The Parties approve the use of electronic signatures for execution of this Agreement. All documents must be properly notarized, if applicable.

This Agreement is executed by the Parties hereto in their respective names as of _____, 20____.

THE CITY AND COUNTY OF BROOMFIELD,
a Colorado municipal corporation and county

Mayor
One DesCombes Drive
Broomfield, CO 80020

APPROVED AS TO FORM:

City and County Attorney

CONTRACTOR:

DESIGN MECHANICAL INCORPORATED,
a Colorado corporation

By:  _____

Ron Pierce, Vice President of Service
312 CTC Blvd.
Louisville, CO 80027

EXHIBIT A
PROJECT PLANS AND SPECIFICATIONS

[See attached.](#)

MECHANICAL/PLUMBING GENERAL NOTES:

1. GENERAL CONSTRUCTION TERMS AND CONDITIONS

- 1.1 ADMINISTRATION**
- A. The author of this document shall be referred to as Consultant in these notes. The project owner or developer shall be Owner. The design professional in direction of Consultants shall be Architect. The person or entity who contracts with the Consultant for the design shall be Client. Contractor(s) shall be responsible for all work within the contract documents.
- B. These documents have been generated at the request of the Client without the benefit of full design specifications defining all systems and components in order to provide the Client/Contractor relationship and construction contract maximum flexibility. The Contractor is fully responsible for providing construction services in accordance with all industry best practices and material and equipment fabricated and assembled in accordance with United States of America industry standards and guidelines.
- C. It is the Contractors responsibility to bid and build from the most recently released contract document drawing set.
- D. The sheets listed in the drawing index on the mech/plbg title sheet shall constitute the contract document drawing set.
- E. Construction Documents (CD) as identified in the title block shall be suitable for bidding purposes and submitted to the local Authority Having Jurisdiction (AHJ) for review and comment. Bids shall be subject to scope of work changes based on AHJ comments.
- F. Drawing Revisions (Rev#) as identified in the title block are considered Changed Conditions.
- G. Upon completion of the work, the Consultant shall, with the written request of Additional Services from the Owner or Client, compile a reproducible set of Record Documents based on the marked-up record drawings, addenda, change orders and other data furnished by the Contractor or other third parties. These Record Documents will show significant changes made during construction. Because these Record Documents are based on unverified information provided by other parties, which the Consultant is entitled to assume will be reliable, the Consultant cannot and does not warrant their accuracy.
- H. RECORD DOCUMENT WARNING: Record Documents are prepared based on information provided by others. The Consultant is under no obligation or duty to verify the accuracy and/or completeness of this information and has not done so. The Consultant shall not be responsible for any errors or omissions that may be incorporated as a result of erroneous information provided by others.
- I. The Contractor shall maintain a marked-up set of drawings, which indicate variations in the actual installation from the original design. Deliver the drawings to the Owner upon completion.

1.2 ACCESSIBILITY

- A. The Owner, Architect, Contractor and Subcontractor shall notify the Consultant of any conditions of the project that they believe do not comply with the current state of the Americans Disability Act (ADA) and/or Fair Housing Act (FHA) before commencement of construction or product procurement.

1.3 CODES AND STANDARDS

- A. Install all air distribution Work in accordance with the most recent addition of SMACNA duct construction standards, guidelines, and specifications and NFPA 90a, 90b, and 91. Install and test all work in compliance with the 2018 (Local State Enforced Code) International Building Codes and the local Authority Having Jurisdiction and code amendments in place.
- B. It is the mechanical / plumbing contractor's responsibility to review and coordinate all line-items on the Project's ComCheck Post Construction Compliance Statement and Inspection Checklist with the Project Architect and Owner. The Contractor shall execute the submittal process, installation of the Projects systems/Equipment, and Project commissioning in a way which satisfies all mechanical, plumbing, and energy code ComCheck line-items assigned to the Contractors scope of work.
- C. Install all equipment and materials in accordance with manufacturer's recommendations unless specifically indicated otherwise by signed agreements between the Consultant, Client/Contractor or where local codes or regulations apply.
- D. The Contractor shall maintain manufacturers recommended service clearance around all equipment unless approved in writing by the Owner or Consultant.
- E. The Consultant put forth reasonable professional efforts to comply with applicable laws, codes, and regulations in effect as of the date of this document. Newly enacted laws, codes and regulations after this date shall entitle the Consultant to a reasonable adjustment in the schedule and additional compensation in accordance with the Additional Services provisions of the Consultants Agreement with the Client.
- F. If the installing Contractor recognizes or is made aware of any conflicts between the contract documents and local installation codes, they shall inform the Consultant of the conflict before work is installed for corrective action.

1.4 COORDINATION

- A. Review the architectural drawings for exact dimensions and locations prior to any mechanical rough in of plumbing fixtures or mechanical equipment.
- B. DO NOT SCALE the mechanical plans. Refer to Architectural plans for wall and fixture locations.
- C. It is the Contractors responsibility to field coordinate the routing of all mechanical and plumbing systems with the other trades and architectural ceiling plans in order to avoid conflicts with ducts, pipes, lights, ceilings, etc.
- D. Coordinate the procurement and installation of equipment requiring attention by more than one trade with the affected trades. Division of Work shall be identified in the full project specifications and contract documents.
- E. The Contractor shall verify the electrical service provided by the electrical contractor and required by the control contractor before ordering any mechanical equipment or equipment controls requiring electrical connections.
- F. In general, the mechanical Contractor supplying motor driven or electrically controlled equipment shall be expected to provide all motor contractors, starters, drives, control transformers, valve motors, damper motors, and related materials necessary for equipment operation. Devices supplied by the mechanical contractor shall be installed by the mechanical contractor and wired by the electrical or temperature control contractor. The electrical Contractor shall provide and wire all necessary fused and non-fused disconnects or equipment switches.
- G. The equipment scheduled and noted on this contract document is for consultant coordination, contractor coordination, and budget estimation purposes only. The Contractor shall obtain submittal documents for all equipment and systems and submit them to the Consultant for review. No equipment shall be ordered until the Consultant has completed a submittal review. The Consultant shall be allowed a minimum of 10 working days for initial submittal review and 5 working days for any re-submittals.
- H. Field verify location and elevation of all existing utilities. Any discrepancies shall be relayed to the Consultant for comment and corrective action as needed.

1.5 DEMOLITION

- A. The demolition contractor shall remove all items indicated on the drawings as to be removed or as defined in their contract and not wanted by the property Owner. Where removal or relocation of existing fixtures or equipment occurs, all waste, vent, gas and water piping branch lines not required for new locations of fixtures or equipment shall be removed back to the main and capped or abandoned in place as indicated on the drawings. All demolished material shall be hauled away from the project site by the demolition contractor.

- A. Where piping has been removed from floor or wall penetrations, the prime contractor shall patch the opening to match existing conditions.
- B. Verify all existing utilities locations (x-ray floors and walls) and obtain building management approval before making any floor or wall penetrations.
- C. All required excavating and backfilling for installation of new plumbing piping shall be performed by the plumbing contractor. Concrete floor sawcutting and patching shall be performed by the prime contractor.
- D. If pipe, insulation, or equipment is to remain and is damaged in appearance or is unserviceable, remove damaged or unserviceable portions and replace with new products of equal capacity and quality.

1.6 NEW EQUIPMENT, FIXTURES AND SYSTEM COMPONENTS

- A. Material, equipment, and fixtures shall be new and free from defects.
- B. All equipment required capacities are scheduled at the jobsite altitude.
- C. All equipment and piping supports suspended from roof joists shall be suspended from the top chord of the joint unless otherwise approved in writing by the Structural Engineer or as indicated on architectural or structural building contractor documents.
- D. All assemblies and components of equipment, pipe, and/or duct hangers, anchors, and support systems including prefabricated and field assembled systems shall be confirmed and documented by the Contractor to have adequate load bearing capacity for the applied support duty. This Consultant assumes no liability for building or equipment support structural or strength analysis.
- E. Seismic rated support or anchorage systems for equipment, piping, and ductwork are not anticipated on this project.
- F. All curbs, roof jacks, roof penetrations, etc. shall be compatible with the specified roofing system. Any work performed shall not limit or affect the roofing material contractor or manufacturer warranty.
- G. All mechanical penetrations of the related walls, ceilings, and floors shall have the annular space around penetrations sealed with a fire barrier sealant meeting the requirements of UL standard 1479 and ASTM-E 814. Install sealant in full compliance with manufacturer's standard installation instructions.
- H. The mechanical or plumbing contractor shall furnish all hole drilling for pipe hangers, floor penetrations and wall penetrations.
- I. Sleeves shall be installed at all piping penetrations through concrete floor or concrete wall construction.
- J. Install all piping and ductwork true and plumb, parallel, or perpendicular to building construction.
- K. Locate all temperature, pressure and flow measuring devices in accessible locations with straight sections of pipe or duct upstream and downstream as recommended by the manufacturer for best accuracy.
- L. If any air moving equipment is to be operated during construction, install temporary dust filters over any air openings of the return air ductwork. If any water moving equipment is to be operated during construction or at system start-up, construction screens shall be placed in all main pipe strainers and pump suction diffusers in the system.

1.7 SUBMITTALS

- A. Dimensioned shop drawings with clearly marked manufacturer and model information, capacities and performance curves at contract document defined altitude and fluid type (temperature, pressure, humidity, and concentration) or necessary performance derates of catalog data as applicable of all scheduled equipment shall be submitted to the Consultant by the Architect, Client or Contractor for review in a formal submittal review process before procurement by the Contractor. Submittals shall also contain clearly marked factory installed or provided options, equipment accessories, fixtures, fixture accessories or trim, necessary plumbing and electrical hook-up capacities and requirements, weight, service clearance requirements, and equipment mounting details as necessary for the contract document application(s).
- REQUIRED SUBMITTALS: It is the Contractor's responsibility and obligation to assemble a submittal package for Consultant review and comment for the minimum following materials and components before procurement
- All components and related accessories logged and scheduled on any equipment or fixture schedules contained on the construction documents.
 - All sheet metal specialties (turning vans, balance dampers, fire/smoke dampers, access panels, duct sealants, condensate neutralization kits, UL listed pre-engineered systems, structural supports)
 - Air Duct Insulation: liner, wrap, vapor barrier, weather jacket.
 - All HVAC piping specialties (valves: isolation, balance (with flow charts/tables), control (with flow and ΔP schedule)), strainers, gauges, ports, coil hook-up kits, condensate neutralization kits, pipe material and fittings, fittings, gaskets and methods, expansion joints, UL listed pre-engineered systems, structural supports, pipe attachment/supports, fluid system flush/clean/kill chemicals).
 - Piping and Tank Insulation: Wrap, vapor barrier, weather jacket, heat trace
 - All plumbing specialties (valves, unions, gauges, pipe material and fittings, fitting joining materials and methods, med. gas outlets, UL listed pre-engineered systems, structural supports, pipe attachment/supports fluid system flush/clean/kill chemicals).
 - All control specialties (sensors, relays, controllers, front-end, conductors, wiring diagrams, sequence of operation).
 - All operation and maintenance records: Project close out documentation, including record documents, O&M manuals, TAB reports, system fluid chemistry reports, applicable ComCheck compliance forms and calculations, as well as training of building operations personnel is required for all mechanical and plumbing components, equipment, and systems operation.

1.8 EQUIPMENT ACCESSORIES AND REMARKS:

- A. Equipment, fixture and component schedules contained in the contract documents shall have listed Accessories and Remarks as necessary. It shall be the Contractors responsibility to budget, submit on, and procure all Accessories or Fixture Trim from the equipment manufacturer or compatible supplier. All components or trim listed under the Remarks are necessary for the installation of the equipment or fixtures and shall be provided by the Contractor.
- B. SUBMITTAL REVIEW: The Consultant shall review and approve or take other appropriate action on the Contractor submittals, such as shop drawings, product data, samples and other data, which the Contractor is required to submit, but only for the limited purpose of checking for conformance with the design concept and the information shown in the Construction Documents. This review shall not include review of the accuracy or completeness of details, such as quantities, dimensions, weights or gauges, fabrication processes, construction means or methods, coordination of the work with other trades or construction safety precautions; all of which are the sole responsibility of the Contractor. The Consultants review shall be conducted with reasonable promptness while allowing sufficient time in the Consultants judgment to permit adequate review. A minimum of 10 working days will be required by the Consultant for a review package containing 50 separate components and materials or less. The Contractor is responsible for building submittal review time into their projects schedule of delivery. Review of a specific item shall not indicate that the Consultant has reviewed the entire assembly of which the item is a component. The Consultant shall not be responsible for any deviations from the Construction Documents not brought to the attention of the Consultant in writing by the Contractor. The Consultant shall not be required to review partial submissions or those for which submissions of correlated items have not been received.
- C. SUBSTITUTIONS: Certain materials and equipment are specified by manufacturer and model or catalog number. Such specified items are the basis of design and establish a degree of quality, performance, and physical configuration. Alternative manufacturers may be used as long as the products retain a similar degree of quality, performance, and physical configuration. Alternate manufacturers and models shall have prior approval from the engineer of record through a formal submittal process before equipment procurement. If alternate equipment, fixtures, or materials require the Consultant to modify and coordinate the construction documents prepared by the Consultant for installation purposes or coordinate with those of the Consultants subconsultants and the Owners or Architects consultants, the Consultant shall be compensated by the Contractor or Client for these services as Additional Services and entitled to adjustment(s) in schedule caused by this additional effort.

1.7 HAZARDOUS MATERIALS—SUSPENSION OF SERVICES

- A. Owner, Architect, and Contractor acknowledge that the Consultants scope of services does not include any services related to the presence of any hazardous or toxic materials in the event the Consultant or any other person or entity involved in the project encounters any hazardous or toxic materials, or should it become known to the Consultant that such materials may be present on or about the jobsite or any adjacent areas that may affect the performance of the Consultants services, the Consultant may, at its sole option and without liability for consequential or any other damages, suspend performance of its services until the Client retains appropriate qualified consultants and/or contractors to identify and abate or remove the hazardous or toxic materials and warrants that the jobsite is in full compliance with all applicable laws and regulations.
- B. The term hazardous materials shall mean any substances, including without limitation asbestos, toxic or hazardous waste, PCBs, combustible gases and materials, petroleum, or radioactive materials (as each of these is defined in applicable federal statutes) and any other substances under any conditions and in such quantities as would pose a substantial danger to persons or property exposed to such substances at or near the Project site.
- 1.8 JOBSITE SAFETY
- A. Neither the professional activities of the Consultant, nor the presence of the Consultant or its employees and subconsultants at a construction/project site, shall impose any duty on the Consultant, nor release the General Contractor and Sub-Contractors of their obligations, duties and responsibilities including, but not limited to, construction means, methods, sequence, techniques or procedures necessary for performing, superintending and coordinating the Work in accordance with the Contract Documents and any health or safety precautions required by any regulatory agencies. The Consultant and its personnel have no authority to exercise any control over any construction contractor or its employees in connection with their work or any health or safety programs or procedures. The General Contractor shall also be responsible for jobsite and worker safety and warrants that this intent shall be carried out in the Contractors contract with the Owner. The General Contractor shall also notify the Consultant and the Consultants subconsultants as additional insureds under the General Contractors policies of general liability insurance.

1.9 DISCOVERY OF MOLD

- A. Owner, Architect and Contractor acknowledge that the Consultants Scope of Services does not include any services related to the presence of mold or other like materials. In the event the Consultant or any other party encounters any mold or other like materials on or about the Project site, or should it become known to the Consultant that such materials may be present on or about the Project site or any adjacent areas that may affect the performance of the Consultants services, the Consultant may, at its option and without liability for consequential or any other damages, suspend performance of its services until the Owner retains appropriate consultants or contractors to identify and abate or remove the mold or other like materials. The Consultant shall not bear any costs, losses, and expenses, including the cost of the Consultants Additional Services, arising out of or in any way connected with the discovery of mold or other like materials.
- B. The Consultant, its officers, directors, employees and subconsultants (collectively, Consultant), to the fullest extent permitted by law, is indemnified and held harmless the against all damages, liabilities, and costs, including reasonable attorney's fees and defense costs, arising out of or in any way connected with the discovery, removal or abatement of any mold or other like materials on or about the Project site.

1.10 MAINTENANCE / WEAR AND TEAR

- A. All structures, mechanical equipment and mechanical systems are subject to wear and tear and environmental and man-made exposures. As a result, all structures, friction surfaces of mechanical equipment and fluids conveyed within pipe and duct systems require regular and frequent monitoring and maintenance to prevent damage and deterioration. Such monitoring and maintenance is the sole responsibility of the Owner. The Consultant shall have no responsibility for such issues or resulting damages. If routine inspections and maintenance of the project are not properly performed, damage (which may include but not be limited to mold) to the structures or excessive wear or mineral deposits on the inside of fluid conveying systems) may occur, for which the Consultant cannot be held responsible.

1.11 CONSTRUCTION, RENOVATION, AND EXISTING CONDITIONS

- A. The drawings are diagramsmatic in nature and are not intended to show all transitions, offsets, etc. necessary for complete system installation. The drawings are based on the best information available to the Consultant including as-built drawings (when provided to the Consultant) and/or field observations. Duct and pipe sizes noted as existing on the drawings must be verified as the size indicated or larger; notify Consultant when verified size is smaller than those listed in the Contract Documents prior to continuation work.
- B. The Contractor shall pre-plan and coordinate with all other contractors, field verify existing conditions and provide all necessary fittings to complete the intent of the drawings. Installer may locate mechanical equipment differently than shown on drawings due to conflicts, if function and/or appearance is not affected and required service clearances are maintained. Ductwork and equipment shall be installed as indicated in the CODES AND STANDARDS section.
- C. When mechanical or plumbing services must be interrupted, the work shall be performed in the evening after the building system has been shut down, or temporary services for the affected areas shall be provided. Notify the property manager and/or Owner 48 hours prior to performing this work.
- D. All existing equipment may not be shown. Remove, relocate, and rework any mechanical equipment indicated (whether indicated on drawings or not) by the removal or reworking of existing piping or ceiling.
- E. Clean and check operation and condition of all existing mechanical equipment and plumbing fixtures/equipment within the confines of the space. Prepare a written list of any deficiencies in equipment operation or condition and submit the list to the Owner prior to completion of the project.

1.12 REQUESTS FOR CLARIFICATION OR INTERPRETATION (RFI)

- A. It is the Contractors responsibility to establish a clear scope of work and verify all equipment dimensions and service clearance requirements in relationship to the workspace prior to ordering and installing equipment. The contractor shall generate an RFI to resolve any perceived conflicts before installing any equipment or systems.
- B. The Contractor may, after exercising due diligence to locate required information, request from the Consultant clarification or interpretation of the requirements of the Contract Documents. The Consultant shall, with reasonable promptness (usually within ten (10) working days), respond to such Contractors requests for clarification or interpretation. However, if the information requested by the Contractor is not contained in the Contract Documents or is reasonably inferable from them, the Contractor shall be responsible to the Owner or Client for all reasonable costs charged by the Consultant to the Owner or Client for the Additional Services required to provide such information.
- C. RFI shall be submitted by the Contractor in writing to the Consultant through the Owner, Architect or Client holding the Consultants contract.

1.13 UNAUTHORIZED CHANGES

- A. In the event the Owner, Architect, Contractor, or anyone for who they are legally liable makes or permits to be made any changes to any reports, plans, specifications, or other construction documents prepared by the Consultant without obtaining the Consultants prior written consent, they shall assume full responsibility for the results of such changes. The author and director of the Unauthorized Changes agree to waive any claim against the Consultant and to release the Consultant from any liability arising directly or indirectly from such changes.
- B. In addition, to the fullest extent permitted by law, the author and director of Unauthorized Changes agree to indemnify and hold harmless the Consultant from any damages, liabilities or costs, including all attorneys' fees and costs of defense, arising from such changes.

1.14 VALUE ENGINEERING

- A. If the Owner, Architect Contractor retains the services of a Value Engineer (VE) to review these plans prepared by the Consultant, these services shall be at their sole expense and shall be performed in a timely manner so as not to delay the orderly progress of the Consultants services. The Consultant shall be notified in writing of the identity of the VE and the VE scope of services. All recommendations of the VE shall be given to the Consultant for review, and adequate time will be provided for the Consultant to respond to these recommendations.
- B. If the Consultant objects to any recommendations made by the VE, it shall so state in writing, along with the reasons for objecting. If, in spite of the Consultants objections, changes in the Construction Documents are ordered by the Owner, Architect or Client, they agree, to the fullest extent permitted by law, to waive all claims against the Consultant and to indemnify and hold harmless the Consultant from any damages, liabilities or costs, including all attorneys' fees and costs of defense, which arise in connection with or as a result of the incorporation of such design changes ordered.
- C. In addition, the Consultant shall be compensated for services necessary to incorporate recommended value engineering changes into reports, drawings, specifications, bidding, or other documents. The Consultant shall be compensated as Additional Service for all time spent to prepare for, review and respond to the recommendations of the VE. The Consultants time for performance of its services shall be equitably adjusted.

1.15 TEST AND BALANCE (TAB)

- A. All scheduled volume flow equipment, flow (air or water) modulating equipment accessories (i.e. motorized valves and dampers), and main distribution system balancing dampers or valves necessary for successful system balancing shall be tested, adjusted, and balanced to +/- 10 percent of scheduled capacities.
- B. A competent and reputable test and balance contractor shall provide test and balance services. Current national certification with NEBB or TABB is required.
- C. Test and balance services shall include: 1) A preliminary TAB plan submitted to the Consultant before substantial completion of project and before site TAB work begins. 2) Cooperation with mechanical and control contractor on site to obtain design flow. 3) A complete TAB report detailing results of TAB work for review by Consultant.

2. AIR DISTRIBUTION

2.1 GENERAL

- A. Air duct and fittings shall be constructed, reinforced and sealed in compliance with applicable drawing details contained in the construction documents and the most recent edition of SMACNA HVAC Duct Construction Standards.
- B. Air Duct Classification Definitions:
- Ductwork Pressure Class (+/- 0.5, 1, 2, 3, 4, 6, 10 in.WC.): Duct construction (gauge, reinforcement, fittings, connections, etc) shall be fabricated for its appropriate pressure class.
 - Ductwork Leakage Class (3,6,12,48 cfm/100sf at 1.0 in.WC.): Duct construction (gauge, reinforcement, fittings, connections, etc.) shall be fabricated with methods appropriate to meet the Leakage Class as tested in accordance with the SMACNA Duct Leakage Test Guidelines when specified below or sheet noted on construction documents.
 - Ductwork Seal Class A: Duct transverse joints, longitudinal seams, connections, and duct wall penetrations shall be sealed with gaskets, sealant tape, sealant mastic or combination thereof to meet SMACNA Duct Leakage Test Guidelines.
 - Ductwork Seal Class B: Duct transverse joints, longitudinal seams, and connections shall be sealed with gaskets, sealant tape, sealant mastic or combination thereof to meet SMACNA Duct Leakage Test Guidelines.
 - Ductwork Seal Class C: Duct transverse joints and connections shall be sealed with gaskets, sealant tape, sealant mastic or combination thereof to meet SMACNA Duct Leakage Test Guidelines.
 - Unsealed Ductwork: All residential ductwork. All commercial ductwork operating between 0.5 and 2.0 in.WC. return air plenums shall not be required to be sealed.

2.2 DEFINITIONS:

- Exterior is defined as outside the building rain/snow enclosure.
- Interior is defined as inside the building rain/snow enclosure.
- Unconditioned space is defined as outside the building thermal envelope
- Exposed is defined as in plain view in a conditioned space.
- Air duct sizes shown on drawings are the actual duct sheet metal dimensions.
- All takeoffs, runouts, and flexible ductwork to diffusers shall be the same size as the diffuser inlet unless otherwise noted.
- All air moving equipment equal to or above 1.0 bhp or all indoor unitary vapor compression refrigeration cycle equipment shall be installed with an appropriate vibration isolation system to reduce sound and vibration transmission into the building structure and connected distribution systems. Duct connections, excluding grease duct and laboratory or dust collection duct, shall be made with flexible reinforced vinyl. Pipe shall be attached with an engineered vibration isolation device. Interior, hung, equipment shall be supported with engineered spring vibration isolators.

2.2 DUCT SEALING

- A. Factory engineered gaskets or fusion welds for polypropylene venting systems.

2.3 AIR DUCT MATERIAL

- A. Combustion air duct shall be galvanized steel, unsealed, Pressure Class 0.5 in.WC. or polypropylene.
- B. Combustion Gas Venting: All venting utilized must be listed as acceptable venting material or systems with-in the appliance manufacturers installation instructions.
- Single and double-wall vent for Category 4 gas appliances shall be factory built and UL listed for condensing flue gas and positive pressure (60 in.WC.) continuous operation. Inner wall hyperferic stainless steel (AL29-4C), outer wall aluminum steel or stainless steel. Fittings, flashing, caps, and connectors shall be gasketed and of a single manufacturer to assure compatibility. Use manufacturer's joining system with silicone sealant or seals rated to flue gas temperatures. Install and drain in accordance with manufacturer's installation instructions.
 - Single-wall vent for Category 4 gas appliances shall be factory built and UL listed for condensing flue gas and positive pressure (20in.WC.) continuous operation. Vent and fitting material shall be polypropylene. Fittings, flashing, caps, and connectors shall be gasketed and of a single manufacturer to assure compatibility. Use manufacturer's joining system with silicone sealant or seals rated to flue gas temperatures. Install and drain in accordance with manufacturers installation instructions.
- 2.4 AIR DUCT INSULATION
- A. When insulation is required, insulation thermal resistance values (R-value) shall be in compliance with the 2018 International Energy Conservation Code. If insulation of a system is indicated below but not required in the ICC, the minimum insulation liner thickness shall be one-half inch with minimum R-value of 2.2 and the minimum insulation wrap lapped thickness shall be one and one-half inch with a minimum installed R-value of 4.0.
- B. Duct wrap shall be glass fiber blanket in thermoset resin. It shall have a maximum flame/smoke index of 25/50, contain no formaldehyde, and be bonded to a metallic foil or polymer semi-impermeable vapor retarder. Wrap shall be manufactured and installed per manufacturer's SMACNA and NAMA guidelines.
- C. In general, the following duct systems shall be uninsulated: combustion gas (exhaust) vent.
- D. In general, the following duct systems shall be wrapped: metal combustion air.

2.5 AIR DUCT FITTINGS AND SPECIALTIES

- A. General: Provide miscellaneous materials and products of types and sizes indicated and, where not otherwise indicated, provide type and size required to comply with ductwork system requirements including proper connection of ductwork and equipment.
- B. Inside hammerlock connections shall not be used in unlined ductwork.
3. HVAC PIPING SYSTEMS

3.1 GENERAL

- A. Provide shut-off duty valves and unions or flanges on all lines to equipment for isolation and removal.
- B. Isolate all pressurized water and gas piping branches for each riser, branch item of equipment, and area served with shut-off duty valves.
- C. Pipe shown on plans is for general routing purposes and plan clarity. The Contractor shall be responsible for pipe routing on site and pipe support coordination; proper pipe sleeving when passing through a wall, ceiling, or floor; and pipe anchoring, guiding, and expansion loops/devices on straight pipe runs where the potential fitting deflection places detrimental stress on the system fittings or building components/expansion loops/devices shall be installed in accordance with the practices detailed in the ASHRAE Systems and Equipment Handbook.
- D. Provide flanges or bronze waterway nipples/couplings at connections between dissimilar metals, e.g., iron valves and copper tubing or black steel and copper tubing.
- E. Pitch drain lines not less than 1/4 inch per foot.
- F. Route all piping on warm side of building insulation. Pipe insulation is not considered freeze protection.
- G. Provide an air vent at the high point of each drop in the heating water, chilled water, condensing water, and other closed water piping systems. All piping shall slope to low points for service drainage. Provide hose end drain valves at the bottom of all risers and low points. Provide valves and fittings necessary for closed loop system fill, flush, air purge, and drain.
- H. All valves (except control valves) shall be piping line size before piping is reduced in size to connect to equipment and controls.
- I. Provide flexible connections in all piping systems connected to pumps, chillers, cooling towers, and other equipment that contain or require vibration isolation on the structural equipment mounts to reduce vibration transmission into the building structure. Install flexible connections as close to equipment as possible or as shown on contract documents.
- J. All water moving equipment equal to or above 3.0 bhp with rotating components shall be installed with an appropriate vibration isolation system to reduce sound and vibration transmission into the building structure and connected distribution systems. Vertical in-line type water pumps are exempted from vibration isolation requirements unless indicated on pipe details. Pipe shall be attached to equipment with an engineered vibration isolation device. Equipment shall be supported with engineered spring vibration isolators or engineered inertia bases.
- K. Test all piping installations per local code requirements. Minimum one- and one-half working pressure, hydrostatically tested using water. Compressed air or gas shall not be used on PVC or CPVC systems more than 5 psi.
- L. All piping and fittings shall be constructed and joined as recognized by ASTM or ASME standards applicable to the material and application.
- M. Construct all heating water (boiler) systems in accordance with the State of Colorado Revised Statutes. Unless variance is documented in writing by the Owner or Client, it is the Contractors responsibility to install all safety, relief valves, and equipment required for approval by the State boiler inspector whether indicated on the drawings or not.
- N. Prior to final fill fluid, hydraulic systems shall be flushed with tap water at a minimum velocity of 4 fps, cleaned with a circulated detergent solution manufactured for cleaning piping systems, and completely drained. Systems utilizing fluxed soldering joining methods shall be flushed within 24 hours of soldering. Final system fluid is specified below. Tap water may be used for final system fluid or to dilute final glycol solutions if the water quality is acceptable as recommended by the glycol and/or corrosion inhibitor manufacturer. Otherwise, demineralized water shall be used. Final system pH shall be between 7.5 and 8.5 and total dissolved solids concentration between 10-30 ppm based on the corrosion inhibitor and glycol manufacturer's recommendations. Purge and bleed all air from the entire system on final solution install. Contractor shall submit a final solution water chemistry analysis report, generated by a 3rd party test lab, to the engineer of record for substantial completion approval.

1. Heating Water System Fluid: 30 percent propylene glycol with inhibitor package.

3.2 PIPING SYSTEM ABBREVIATIONS

- A. HWS/R: Heating Water Supply/Return.
- B. FILL: Fill Line.
- C. D: Drain.

3.3 PIPING AND FITTING MATERIALS

- All piping, gaskets, and fittings shall be constructed, certified, and labeled where applicable, and joined as recognized by ASTM, NSF, or ASME standards applicable to the material and application.
- A. Black steel, schedule 40, plain ends, and welded fittings. All systems above grade. Piping system may use compatible Victaulic grooved pipe and fittings in accordance with Victaulic installation standards. All systems 2.5" and larger.
1. HWS/R.
- B. Type L hard drawn copper tubing with soldered joints, 95 percent tin / 5 percent antimony lead free solder and wrought-copper fittings. All systems 3 inch or smaller in nominal size. Press joints are allowed.
1. HWS/R.
2. FILL.
3. D.
- C. Type M or Type DWV copper tubing with wrought copper fittings and 95 percent tin / 5 percent antimony lead free solder. Copper tubing may not be used with acidic condensate from condensing gas fired appliances.
1. D.
- D. PVC, schedule 40 with socket-type with solvent welded joints and fittings. PVC is not allowed in return air plenums.
1. D.

3.4 PIPING/VALVE INSULATION

- A. Insulation thickness and thermal conductivity shall meet minimum IECC values. The thickness of insulation for piping installed exposed to the exterior environment shall be increased by 1/2" above the minimum thickness required by the IECC.
1. HWS/R Piping (1 1/2 in. and less): 1 1/2 in.
2. HWS/R Piping (1 1/2 in. and greater): 2.0 in.
- B. Allowable insulation types on above ground piping with design fluid temperatures between 100 F and 220 F: Fiberglass, Cellular Glass, Closed-Cell Elastomeric Foam, Polyurethane, Polysocyanurate.
- C. Allowable insulation types on above ground piping with design fluid temperatures below 60 F: Fiberglass, Cellular Glass, Closed-Cell Elastomeric Foam, Polyurethane, Polysocyanurate.
- D. A semi-impermeable vapor retarding layer shall be installed or integrated into the outer insulation jacket on all piping with design fluid temperatures below 60 F. g/rn aluminum weather jacket shall not be considered a vapor retarder. Vapor retarding layers shall be installed with taped and sealed joints, penetrations, and ends to maintain a continuous vapor retarding layer. Vapor retarding layers are allowed on all piping systems.
- E. Insulation installed in return air plenums shall have jackets meeting 25/50 flame spread/smoke development ratings.
- F. Isolation valves, throttling valves, check valves, flow measurement components, unions, drains, and air vents on all piping systems except chilled water shall be uninsulated.

3.5 PIPING FITTINGS AND SPECIALTIES

- A. General: Provide miscellaneous materials and products of types and sizes indicated and, where not otherwise indicated, provide type and size required to comply with piping system requirements including proper connection of piping and equipment.
- B. Hangers: Provide pipe hangers of the same material as the piping system or use coated hangers. Metal hangers for plastic piping is permitted. Hanger and riser clamp spacing shall comply with local codes. Hanger systems for piping with fluids below 60 F or above 130 F must incorporate a substantial thermal break between the pipe and hanger to reduce the transfer of heat and accommodate pipe thermal expansion.
- C. Valves: Use ball and butterfly valves for shut-off duty. Use globe, ball, and butterfly valves for throttling duty. All ball valves shall be full port assemblies. Use crutch-setter type calibrated balancing valves with integral seats and equipped with a memory stop to retain set position where indicated on drawings. In general, valves used be compatible with piping systems used, 125 psig working pressure and 250 F maximum operating temperature. Calibrated balancing valves shall be sized within zero and 75 percent of the manufacturers recommended flow range.
- D. All valves and strainers (except control valves and in some instances balancing valves) shall be piping line size before piping is reduced in size to connect to equipment and controls.
- E. All valves shall be adjusted (valve packing, lubrication, etc.) for smooth, low effort operation.
- F. Gauges: Contractor shall install temperature and pressure gauges of appropriate range and duty where indicated on piping schematics and installation details.
- G. Piping Installation: Install drains, consisting of 1/2" ball valve and short threaded nipple with hose end and cap at low points in piping system mains and elsewhere as required for system drainage. Reduce pipe sizes using eccentric reducer fittings, installed with level side up. Install branch connections to mains using tee fittings in main pipe with the takeoff coming out the bottom of the main pipe. For up-flow risers, install the takeoff coming out the top of the main pipe.
- H. Piping-to-be connections on copper piping systems shall be allowed. The connection shall be brazed in place and the branch pipe insertion depth shall be positively set so as not to protrude into the fluid stream.
- I. Weld-on-let branch connections on steel piping systems shall be allowed only for approved system/design modifications and when approved in writing by the Consultant. When used, the entire connection area on the main pipe shall be machined out and the edges made smooth.

3.6 IDENTIFICATION

- A. Identify (label) all piping system contents and flow directions according to ANS/ASME labeling guidelines with pressure sensitive flexible vinyl film, tape, paint, or other approved media suitable for the application.

4. PLUMBING SYSTEMS

4.1 GENERAL

- A. The plumbing Contractor shall be fully responsible for all damage caused by leaks in piping systems which he has built or modified in any way. All damage shall be repaired and replaced to the satisfaction of the property manager.
- B. Provide shut-off duty valves, unions, flanges, or waterway nipples on all lines to equipment for isolation and removal.
- C. Isolate all pressurized water and gas piping branches for each riser, branch item of equipment, and area served with shut-off duty valves.
- D. Provide dielectric unions, flanges, or waterway nipples at connections between dissimilar metals, e.g., stainless steel and copper tubing.
- E. All equipment and piping supports suspended from roof joists shall be suspended from the top chord of the joint.
- F. Pipe shown on plans is for general routing purposes and plan clarity. The Contractor shall be responsible for pipe routing on site and pipe support coordination as well as proper pipe sleeving when passing through a wall, ceiling, or floor and pipe anchoring, guiding, and expansion loops/devices on straight pipe runs where the potential fitting deflection places detrimental stress on the fitting.
- G. Pitch drain lines not less than 1/4 inch per foot.
- H. Pitch waste lines 2 in. and smaller, not less than 1/8" per foot. Pitch waste lines 3 through 6 in. 1/8" per foot. Pitch waste lines 8 in. and larger, not less than 1/16" per foot.
- I. Route all piping on warm side of building insulation. Pipe insulation is not considered freeze protection.
- J. All valves (except control valves) shall be piping line size before piping is reduced in size to connect to equipment and controls.
- K. Provide flexible connections in all piping systems connected to pumps and other equipment that require vibration isolation on the structural equipment mounts. Install structural equipment mounts to reduce vibration transmission into the building structure. Install flexible connections as close to equipment as possible or as shown on contract documents.
- L. Test all piping installations per local code requirements. Working, vent, and storm systems shall be tested at 5 psi or 10 feet of water column. All other plumbing systems shall be tested at a minimum one- and one-half working pressure, hydrostatically tested using water. Compressed air or gas shall not be used on PVC or CPVC systems more than 5 psi.
- M. Cold domestic water distribution is sized for a maximum peak demand of 8 gpm. Domestic water distribution is sized for a maximum velocity of 5 ft. Field changes to distribution sizes must be approved in writing by the Consultant to ensure that velocities are maintained in accordance with project building codes.
- N. Install all piping without forcing or springing. All piping shall clear windows, doors, and access panels.
- O. Construct all hot water (boiler) systems in accordance with the State of Colorado Revised Statutes. Unless variance is documented in writing by the Owner or Client, it is the Contractors responsibility to install all safety, relief valves, and equipment required for approval by the State boiler inspector whether indicated on the drawings or not.
- P. Prior to final system fill, domestic water systems shall be flushed with water at a minimum velocity of 4 fps, sterilized, and completely drained. Systems utilizing fluxed soldering joining methods shall be flushed within 24 hours of soldering. Final system chemistry shall be tested for minimum levels of sterilizing chemicals acceptable by the chemical manufacturer.

(CONTINUES ON SHEET MPI.1)



CITY AND COUNTY OF BROOMFIELD
DETENTION CENTER
HW-DHW PLANT RENOVATION
11600 RIDGE PKWY, BROOMFIELD, CO 80021

ISSUE/REVISION	DATE	NO.
100% CDS	05/09/22	
ASI #1	06/13/22	
ASI #2	03/26/24	

MECH/PLUMB GENERAL NOTES

DRAWN BY	JMB
DESIGN BY	JMB
CHK'D BY	KAM

THIS DOCUMENT, INCLUDING ALL IDEAS AND DESIGNS, IS THE PROPERTY OF 20/20 ENGINEERING, INC. WHO HAS PROVIDED A PROFESSIONAL DESIGN SERVICE AND CANNOT BE REPRODUCED OR DUPLICATED IN WHOLE OR IN PART BY ANY OTHER PARTY FOR PERMIT, BIDDING OR INSTALLATION PURPOSES FOR THIS OR ANY OTHER PROJECT WITHOUT THE WRITTEN AUTHORIZATION OF 20/20 ENGINEERING, INC. SHEET NUMBER:

MPI.1

MECHANICAL/PLUMBING GENERAL NOTES (CONTINUED):

(CONTINUED FROM MP1.1)

4.2 PIPING SYSTEM ABBREVIATIONS

- A. HW: Domestic Hot Water.
 B. HWC: Domestic Hot Water Circulating.
 C. CW: Domestic Cold Water.
 D. G: Natural Gas.
 E. D: Drain.

4.3 PIPING AND FITTING MATERIALS

- A. All piping, gaskets, and fittings shall be constructed, certified, and labeled where applicable, and joined as recognized by ASTM, NSF, or ASME standards applicable to the material and application. Cast iron soldered waste products shall be recognized by CSPI, and installed per CSPI Standards, including CSPI 301-12 or most current edition.
 B. Black steel, schedule 40, plain ends, and welded fittings. All systems above grade. Piping routed through exterior environments shall be painted to protect for corrosion, as approved by local code. (2 1/2 in. diameter and larger)
 I. G.
 C. Black steel, schedule 40, threaded joints, and class 150 malleable-iron threaded fittings. All systems above grade. Piping routed through exterior environments shall be painted to protect for corrosion, as approved by local code. (2" diameter and smaller). Viega Mega-press joints are allowed.
 I. G.
 D. Type K hard drawn copper tubing with soldered joints, 95 percent tin / 5 percent antimony lead free solder and wrought-copper fittings.
 I. HW / HWC / CW
 E. Type L hard drawn copper tubing with soldered joints, 95 percent tin / 5 percent antimony lead free solder and wrought-copper fittings. All systems 2 inch or smaller in nominal size. Press joints are allowed.
 I. HW / HWC / CW
 I. D.
 F. Type M or Type DWV copper tubing with wrought copper fittings and 95 percent tin / 5 percent antimony lead free solder. Copper tubing may not be used with acidic condensate from condensing gas fired appliances.
 I. D.
 G. PVC, schedule 40 with socket-type with solvent welded joints and fittings. PVC is not allowed in return air plenums.
 I. D.

4.4 PIPING/VALVE INSULATION

- A. Insulation thicknesses based on a thermal conductivity (k value) of 0.27 shall meet or exceed the values listed below. Insulations with a k value above 0.27 shall have their thickness increased by 1/2 inch. The thickness of insulation for piping installed exposed to the exterior environment shall be increased by 1 inch above the thickness indicated below. The thickness of insulation for direct buried Polyolefin insulation systems shall be a minimum of 1 inch.
 I. HW / HWC Piping (1 1/4 in. and less): 1 in.
 II. HW / HWC Piping (1 1/2 in. and greater): 1 1/2 in.
 III. CW Piping (1 1/4 in. and less): 1/2 in.
 IV. CW Piping (1 1/2 in. and greater): 1 in.
 B. Allowable insulation types on above ground interior piping: Fiberglass, Cellular Glass, Closed-Cell Elastomeric, Polyurethane, Polysocyanurate.
 C. A semi-impermeable vapor retarding layer shall be installed or integrated into the outer insulation jacket on all piping with normal operating fluid temperatures below 60 F. An aluminum weather jacket shall not be considered a vapor retarder. Vapor retarding layers are allowed on all piping systems.
 D. Vapor retarding layers shall be installed with taped and sealed joints, penetrations, and ends to maintain a continuous vapor retarding layer.
 E. Insulation installed in return air plenums shall have jackets meeting 25/50 flame spread/smoke development ratings.
 F. Isolation valves, throttling valves, check valves, flow measurement components, unions, drains, and air vents on all piping systems except cold water shall be uninsulated.
 G. On cold water systems, isolation valves, throttling valves, and flow measurement components shall be insulated and provided with extended ports and valve stems. Check valves and unions shall be insulated with diamond type removable insulation covers. Drains, air vents, and sight glasses shall be uninsulated.

4.5 PIPING FITTINGS AND SPECIALTIES

- A. General: Provide miscellaneous materials and products of types and sizes indicated and, where not otherwise indicated, provide type and size required to comply with piping system requirements including proper connection of piping and equipment.
 B. Hangers
 I. Provide pipe hangers of the same material as the piping system or use coated hangers. Metal hangers for plastic piping are permitted.
 II. All hanger materials exposed in a natorium environment must be hot dipped galvanized or 300 grade stainless steel.
 III. Hanger and riser clamp spacing shall comply with local codes.
 IV. Hanger systems for piping with fluids below 60 F or above 130 F must incorporate a substantial thermal break between the pipe and hanger to reduce the transfer of heat and accommodate pipe thermal expansion.
 C. Valves:
 I. Use ball valve on 2 in. diameter and smaller and butterfly valves on 2 1/2 in. diameter and larger for shutoff duty.
 II. Use globe, ball, and butterfly valves for throttling duty. All ball valves shall be full port assemblies.
 III. Use circuit-setter type calibrated balancing valves with integral seals and equipped with a memory stop to retain set position where indicated on drawings. Calibrated balancing valves shall be sized within zero and 60 percent of the manufacturers recommended flow range.
 IV. In general, valves shall be compatible with piping systems used, 125 psig working pressure and 250 F maximum operating temperatures
 D. All valves, including but not limited to isolation, check, control, and balancing valves installed in domestic water systems and are in contact with domestic water shall be of lead-free construction and made of de-zincification resistant brass alloy.
 E. All valves and strainers (except control valves and in some instances balancing valves) shall be piping line size before piping is reduced in size to connect to equipment and controls.
 F. All valves shall be adjusted (valve packing, lubrication, etc.) for smooth, low effort operation.
 G. Floor and ground cleanouts (FCO, GCO) shall have a satin nikaloy rim and scoriated floor plate with c.o. cast in the plate and secured with countersunk screws to cast iron adjustable collar and bronze countersunk plug and inside caulk outlet.
 H. Wall cleanouts (WCO) shall have a brass countersunk plug and polished chrome round access cover plate secured to plug by countersunk screw.
 I. Reduced pressure backflow preventers (RPBP) shall have an all brass body and covers, spring loaded check valves, parts serviceable while the body is still in line and ball type isolation valves. The air gap fitting shall be compatible with the RPBP and sized adequately to accommodate discharge flow.
 J. Gauges: Contractor shall install temperature and pressure gauges of appropriate range and duty where indicated on piping schematics and installation details.
 K. Valve actuator, spring, control signal, and power whether scheduled on the plans or not shall be coordinated by the supplying contractor with the temperature control contractor before submittal or procurement.
 L. Piping installations: Install drains, consisting of 1/4" ball valve and short threaded nipple with hose end and cap at low points in piping system mains, and elsewhere as required for system drainage.
 M. Install branch connections to mains using tee fittings in main pipe with the takeoff coming out the bottom of the main pipe. For upflow risers, install the takeoff coming out the top of the main pipe.
 N. Piped tee branch connections on copper piping systems shall be allowed. The connection shall be brazed in place and the branch pipe insertion depth shall be positively set so as not to protrude into the fluid stream.
 O. Transition between metallic and PVC drainage systems shall be done with the use of a mission type coupling with 304 stainless steel clamps and collar certified by NSF.
 4.6 IDENTIFICATION
 A. Identify (label) all piping system contents and flow directions according to ANSI/ASME labeling guidelines with pressure sensitive flexible vinyl film, tape, paint, or other approved media suitable for the application.
 5. CONTROLS
 5.1 GENERAL
 A. TCC shall supply, install, and commission all necessary materials and components to implement the sequence of operation.
 B. 120 VAC and 24 VAC control wiring shall be of sufficient gauge and insulation to comply with all control component manufacturer's installation recommendations and voltage/amp requirements. In general, the electrical contractor is responsible for installing 120 VAC wiring in accordance with NEC and the temperature control contractor is responsible for all control components and 24 VAC (low voltage) wiring. Location of components shall be field coordinated between E.C. and T.C.C. wiring and control components shall allow equipment to cycle, stage, operate, measure and monitor operation in accordance with the control sequence of operations or per manufacturer recommendations for stand-alone components.

WATER HEATER SCHEDULE (INSTANTANEOUS)																		
TAG	MANUFACTURER	MODEL NO.	AREA SERVED	FUEL TYPE	MBH INPUT (SL)	MBH OUTPUT (ALT)	RECOVERY 100' F RISE (GPH)	DIMENSIONS			ELECTRICAL			WEIGHT		ACCESSORIES	REMARKS	
								DEPTH (IN)	HEIGHT (IN)	WIDTH (IN)	VOLTS (V)	PHASE (A)	AMPS (A)	PANEL	SHIPPING (LBS)			OPERATING (LBS)
IWH-1,2,3,4	RINNAI	TRS04CU	DOM HOT WATER	NATURAL	796	764	917	28.6	57.7	47	120	1	16	LB-53	562	365	ALL	ALL
IWH-5,6,7,8	RINNAI	TRS04CU	DOM HOT WATER	NATURAL	796	764	917	28.6	57.7	47	120	1	16	LB-55	562	365	ALL	ALL

GENERAL NOTES:

- JOB SITE ELEVATION = 5420 FT.
- CAPACITIES SCHEDULED AT JOB SITE ELEVATION.
- PROVIDE MANUFACTURER'S RECOMMENDED CLEARANCE AROUND UNIT.

ACCESSORIES:

- 4 UNIT FREE-STANDING FRAME WITH PRE-PIPED HEADERS.
- PRESSURE AND TEMPERATURE RELIEF VALVE RATED FOR APPLIANCE CAPACITY.
- HEAT TRAP DIELECTRIC UNIONS.
- 4" ROUND COMBINED EXHAUST VENT/COMBUSTION AIR DUCT.
- COMBUSTION AIR DUCT AND EXHAUST VENT FITTINGS AND CONNECTORS.
- 0.25-0.5 PSIG NAT. GAS MODULATING BURNER.
- SS HEAT EXCHANGER FOR DOMESTIC WATER AND CONDENSING APPLICATIONS.
- PRE-ENGINEERED, FACTORY POLYPROPYLENE EXHAUST VENT AND COMBUSTION AIR DUCT MANIFOLD SYSTEM.

REMARKS:

- REFER TO PIPING DETAIL FOR COMPONENT PIPING.
- ROUTE P&T DISCHARGE TO FLOOR DRAIN SHOWN ON PLANS.
- INSTALL EXHAUST VENT/COMBUSTION AIR DUCTS AND ACCESSORIES PER MANUFACTURER'S RECOMMENDATIONS.
- DISCONNECT BY E.C.
- COLD WATER/HOT WATER/GAS/CONDENSATE CONNECTIONS BETWEEN WATER HEATERS AND PIPING HEADERS INCLUDED AS PART OF FRAME SYSTEM, FIELD ASSEMBLED.
- ANCHOR WATER HEATER FRAME STAND TO HOUSEKEEPING PAD WITH 3/8" EPOXY ANCHOR BOLTS.
- A SINGLE CONDENSATE NEUTRALIZATION TANK PIPED TO EACH RACK CONNECTION. AXIOM MODEL #NT15.
- EXHAUST VENT ROOF TERMINATION KIT.
- EXHAUST VENT/COMBUSTION AIR DUCT CLEANOUTS AND EXHAUST VENT CONDENSATE DRAIN.
- HIGH LIMIT AND LWCO SAFETIES AS PER STATE REQUIREMENTS.

STORAGE TANK SCHEDULE										
TAG	MANUFACTURER	MODEL NO.	AREA SERVED	STORAGE CAPACITY (GAL)	TANK DIMENSIONS		WEIGHT		ACCESSORIES	REMARKS
					DIA. (IN)	HEIGHT (IN)	SHIPPING (LBS)	OPERATING (LBS)		
ST-1	STATE	UVG42-0500-A125	WHOLE BUILDING	504	42	88	1587	5790	ALL	ALL
ST-2	STATE	UVG42-0500-A125	WHOLE BUILDING	504	42	88	1587	5790	ALL	ALL

GENERAL NOTES:

- JOB SITE ELEVATION = 5300 FT.
- CAPACITIES SCHEDULED AT JOB SITE ELEVATION.
- PROVIDE MANUFACTURER'S RECOMMENDED CLEARANCE AROUND UNIT.

ACCESSORIES:

- UNJACKETED.
- VERTICAL TANK WITH FLOOR STAND/BASE.
- 125 PSI WORKING PRESSURE.
- ASME STEEL TANK CONSTRUCTION CEMENT LINED.
- ANODE.
- 100 PSI, 180F ASME P&T RELIEF.
- MANHOLE INSPECTION PORT.

REMARKS:

- G.C. TO PROVIDE 4" HOUSEKEEPING PAD UNDER UNIT. MINIMUM 4" BEYOND UNIT PLAN DIMENSIONS.
- STORAGE TANKS TO BE PIPED IN REVERSE RETURN, EQUAL FLOW PIPING ARRANGEMENT.
- PROVIDE AQUASTAT WITH ADJ. SETPOINT AND DIFF IN TANK. SEE PIPING SCHEMATIC FOR MORE INFORMATION.
- MC/PC SHALL FIELD INSULATE WITH 2 INCHES OF INSUL JACKET INSULATION WITH ALUMINUM OR POLY SHELL.

PLUMBING FIXTURE SCHEDULE					
TAG	DESCRIPTION	FIXTURE MANUFACTURER/MODEL NO.	SERVICE	PANEL	REMARKS
EMV-1	DIGITAL THERMOSTATIC MIXING VALVE	CALEFFI LEGIOMIX #600096A	2009 ADDITION (RCP-1)	LB-57	2" DIGITAL WATER MIXING CONTROL VALVE SYSTEM. ASSE 1017 CERTIFIED. 150 PSI MAXIMUM WORKING PRESSURE. 2" PRESS FITTING INLETS/OUTLETS. BRASS BODY AND CHROME PLATED BRASS BALL VALVE. MAXIMUM CAPACITY = 83 GPM AT 3 PSI PRESSURE DROP. ALL COMPONENTS SHALL BE LEAD FREE AND NSF 372 COMPLIANT. 120/24VAC PWR SUPPLY AND CONTROLLER 12.5 VA. PROVIDE WITH BACNET MS/TP GATEWAY FOR INTEGRATION WITH BAS.
[R] EMV-2	DIGITAL THERMOSTATIC MIXING VALVE	CALEFFI LEGIOMIX 6000 SERIES	ORIGINAL BLDG (RCP-2)	-	SHOWN FOR REFERENCE ONLY. SUPPLEMENT EXISTING INSTALLATION WITH NEW BACNET GATEWAY OR EXTEND MODBUS NETWORK FROM NEW EMV-1 FOR INTEGRATION WITH BAS.

DOMESTIC HOT WATER PUMP SCHEDULE																	
TAG	MANUFACTURER	MODEL NO.	AREA SERVED	PUMP TYPE	CAPACITY (GPM)	HEAD (FT.WC)	ELECTRICAL				DIMENSIONS			ACCESSORIES	REMARKS	CONTROLS	
							VOLTS	PHASE	WATTS	FLA (AMPS)	PANEL	INLET	L				H
WHP-1	GRUNDFOS	UPS 32-160 SF B	STORAGE TANKS	IN-LINE	20	40	115	1	625	5.8	LB-57	1.5	6.5	7.5	ALL	1,2	I
WHP-2	GRUNDFOS	UPS 32-160 SF B	STORAGE TANKS	IN-LINE	20	40	115	1	625	5.8	LB-57	1.5	6.5	7.5	ALL	1,2	I
[E]RCP-1	BELL AND GOSSETT	NBF-45	2009 EXPANSION (110F / EMV-1)	IN-LINE	5	20	115	1	270	5.8	-	1	-	-	-	2,3	I
[R]RCP-2	BELL AND GOSSETT	60 11/2 A	ORIGINAL BUILDING (110F / EMV-2)	IN-LINE	10	30	115	1	550	0.75	-	1	-	-	-	2,3,4	I
[R]RCP-3	GRUNDFOS	UPS15-58FC	ORIGINAL BUILDING (140F)	IN-LINE	2	20	115	1	87	0.75	-	0.75	-	-	-	2,3,4	I

GENERAL NOTES:

- INSTALL ALL EQUIPMENT WITH MANUFACTURER RECOMMENDED SERVICE CLEARANCES.

ACCESSORIES:

- BRONZE HOUSING.
- STAINLESS STEEL IMPELLER.
- STAINLESS STEEL SHAFT.
- DIRECT COUPLED MOTOR.
- NSF-61 RATING FOR DOMESTIC WATER APPLICATIONS.
- 3 SPEED MOTOR (MANUAL SPEED SELECTION).
- FLANGED CONNECTION.

CONTROLS:

- REFER TO SEQUENCE OF OPERATION.

REMARKS:

- SUPPORT PIPING SEPARATELY FROM PUMP
- PUMP SPEED AND FLOW SET BY TAB.
- EXISTING PUMP SHOWN FOR REFERENCE ONLY.
- RELOCATE EXISTING PUMP.

DOMESTIC HOT WATER EXPANSION TANK SCHEDULE																	
TAG	MANUFACTURER	MODEL	AREA SERVED	MAXIMUM ACCEPTANCE VOLUME (GAL)	TOTAL TANK VOLUME (GAL)	FILL TEMP. (F)	MAX TEMP. (F)	PRECHARGE TANK PRESSURE (PSIG)	SYSTEM FILL PRESSURE (PSIG)	MAXIMUM SYSTEM PRESSURE (PSIG)	DIMENSIONS			SHIP WEIGHT (LBS)	OPER WEIGHT (LBS)	ACCESSORIES	REMARKS
											HEIGHT (IN)	DIAMETER (IN)	TANK CONNECTION (IN)				
ET-1	AMTROL	THERM-X-TROL ST-80VC	HEATING WATER	35	53	50	140	55	60	90	36	22	1 1/4	224	516	ALL	ALL

ACCESSORIES:

- BRASS AIR CHARGE FITTING.
- CORROSION-RESISTANT LINER SUITABLE FOR USE WITH DOMESTIC WATER SYSTEMS.
- BASE TO BE MOUNTED ON EQUIPMENT PAD.
- VERTICAL TANK ORIENTATION.
- ASME CONSTRUCTION.

REMARKS:

- TANK PRE-CHARGE PRESSURE TO MATCH SYSTEM FILL PRESSURE. FIELD VERIFY PRIOR TO SYSTEM START UP

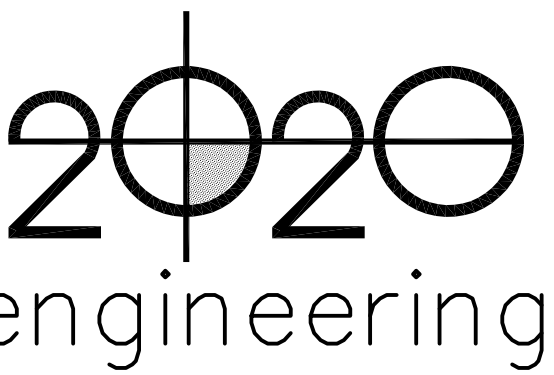

mechanical engineers/consultants
 2051 Dogwood St., Suite 230
 Louisville, CO 80027
 ph. — 303.926.0020, www.2020engineer.com



CITY AND COUNTY OF BROOMFIELD
 DETENTION CENTER
 HW-DHW PLANT RENOVATION
 11600 RIDGE PKWY, BROOMFIELD, CO 80021

ISSUE/REVISION	DATE	NO.
100% CDS	05/09/22	
ASI #1	06/13/22	
ASI #2	03/26/24	

MECH./PLUMB. GENERAL NOTES & PLUMB. SCHEDULES

DRAWN BY	JMB
DESIGN BY	JMB
CHK'D BY	KAM

THIS DOCUMENT, INCLUDING ALL IDEAS AND DESIGNS, IS THE PROPERTY OF 20/20 ENGINEERING, INC. WHO HAS PROVIDED A PROFESSIONAL DESIGN SERVICE AND CANNOT BE USED OR DUPLICATED IN WHOLE OR IN PART BY ANY OTHER PARTY FOR PERMIT, BIDDING OR INSTALLATION PURPOSES FOR THIS OR ANY OTHER PROJECT WITHOUT THE WRITTEN AUTHORIZATION OF 20/20 ENGINEERING, INC. COPYRIGHT 2024.

SHEET NUMBER:

MP1.2

20/20 PROJECT # 22020

BOILER SCHEDULE (GAS)																						
TAG	MANUFACTURER	MODEL NO.	AREA SERVED	HEATING								ELECTRICAL				DIMENSIONS			OPER WEIGHT (LBS)	ACCESSORIES	REMARKS	
				INPUT (MBH)	SL OUTPUT (MBH)	ELEV OUTPUT (MBH)	FUEL TYPE	EWT. (F)	LWT (F)	DESIGN FLOW (GPM)	DESIGN HEAD (FT.WC)	VOLTS (VAC)	PHASE	FLA (AMP)	PANEL	L (IN)	W (IN)	H (IN)				
B-1	AERCO	PLATINUM - BMK1000	ENTIRE BUILDING	1000	960	872	NG	115	140	75	7	115	1	13	LB	25	28	78	819	ALL	ALL	
B-2	AERCO	PLATINUM - BMK1000	ENTIRE BUILDING	1000	960	872	NG	115	140	75	7	115	1	13	LB	25	28	78	819	ALL	ALL	

- GENERAL NOTES:
- JOB SITE ELEVATION = 5420FT.
 - CAPACITIES SCHEDULED AT JOB SITE ELEVATION
 - PROVIDE 36 INCH CLEARANCE IN FRONT OF DISCONNECT PER NEC
 - PROVIDE MANUFACTURER RECOMMENDED CLEARANCE AROUND UNIT
 - LOCATE VENT DISCHARGE A MINIMUM OF 10 FEET FROM ANY BUILDING OPENINGS AND 2 FEET ABOVE ANY PART OF THE BUILDING WITH IN 10 FEET. EXISTING ROOF PENETRATION WILL BE REUSED. FIELD VERIFY IT MEETS REQUIREMENTS
- ACCESSORIES:
- STAINLESS STEEL HEAT EXCHANGER
 - FORCED DRAFT BURNER
 - HOT SURFACE IGNITION
 - 75 (PSIG) ASME RELIEF VALVE, MINIMUM 1000 MBH INPUT
 - ASME CSD-1 COMPLIANT BOILER, GAS TRAIN, AND SAFETY ACCESSORIES FOR CSD-1 COMPLIANT INSTALLATION.
 - CONDENSATE DRAIN TRAP.
 - HIGH AND LOW GAS PRESSURE SWITCHES
 - LOW WATER CUT-OFF AND HIGH LIMIT SAFETIES
 - NATURAL GAS OPERATING PRESSURE: 4-14 PSIG
 - MODULATING HEAT, MINIMUM 20:1 TURNDOWN RATIO
 - DUCTED COMBUSTION AIR WITH CLEANABLE FILTER
 - INSULATED METAL JACKET.
- M. CATEGORY IV MANIFOLDED VENTING ALLOWED WITH POLYPROPYLENE VENT SYSTEMS
- N. FACTORY INSTALLED BOILER CONTROLS FOR PARALLEL BOILER LEAD/LAG, CASCADE FIRE CONTROL, AND SYSTEM PUMP OPERATION
- O. FACTORY INSTALLED COMBUSTION CONTROLS AND MONITORING

- REMARKS:
- GC TO REUSE EXISTING HOUSEKEEPING PAD UNDER UNIT VERIFY IT IS NOT DAMAGED AND MEETS MINIMUM SIZE REQUIREMENTS
 - VENT CONNECTION SIZE IS 6 INCH RND SEE PLANS FOR VENT SIZING AND ROUTING. TERMINATE EXHAUST WITH A VERTICAL VELOCITY CONE IN HIGH WIND AREA.
 - COMBUSTION AIR CONNECTION SIZE IS 6 INCH RND. SEE PLANS FOR VENT SIZING AND ROUTING. TERMINATE COMB. AIR AT EXISTING INLET LOUVER PLENUM BOX.
 - A SINGLE CONDENSATE NEUTRALIZATION TANK PIPED TO EACH BOILER TRAP. AXIOM MODEL #NT15
 - MC RESPONSIBLE FOR HW SYSTEM DRAIN, GLYCOL STORAGE, SYSTEM CLEANING, FLUSH, GLYCOL FILL (30 PCT) AND AIR-PURGE.

HEATING WATER PUMP SCHEDULE																	
TAG	MANUFACTURER	MODEL NO.	AREA SERVED	PUMP TYPE	CAPACITY (GPM)	HEAD (FT.WC)	ELECTRICAL				DIMENSIONS			ACCESSORIES	REMARKS		
							VOLTS	PHASE	WATTS	HP	FLA (AMPS)	PANEL	INLET			L	H
PP-1	GRUNDFOS	UPS 40-80/2 F	B-1	IN-LINE	75	12.0	115	1	480	-	4.5	LB	2.5	13.5	12.4	A,B,C,F,G,H,I,K	1,2,3
PP-2	GRUNDFOS	UPS 40-80/2 F	B-2	IN-LINE	75	12.0	115	1	480	-	4.5	LB	2.5	13.5	12.4	A,B,C,F,G,H,I,K	1,2,3
SP-1	GRUNDFOS	TPE3 40-240 S-A-G-A-BQOE-HCC	SECONDARY HYDRONIC LOOP	IN-LINE, VS. SMART	75	60	460	3		2	2.8	HB	2.5	8.5	18.2	A,B,C,D,E,F,G,H,J	1,2
SP-2	GRUNDFOS	TPE3 40-240 S-A-G-A-BQOE-HCC	SECONDARY HYDRONIC LOOP	IN-LINE, VS. SMART	75	60	460	3		2	2.8	HB	2.5	8.5	18.2	A,B,C,D,E,F,G,H,J	1,2

- GENERAL NOTES:
- 30 PCT PROPYLENE GLYCOL (WITH CORROSION INHIBITORS) IN BUILDING HEATING WATER SYSTEM.
 - INSTALL ALL EQUIPMENT WITH MANUFACTURER RECOMMENDED SERVICE CLEARANCES.
- ACCESSORIES:
- CAST IRON VOLUTE
 - COMPOSITE POLYMER IMPELLER
 - STAINLESS STEEL (304) SHAFT
 - PERMANENT MAGNET MOTOR AND CONTROLLER FOR VARIABLE SPEED CONTROL
 - PUMP TO PUMP COMMUNICATION VIA WIRELESS COMM. CIM COMM MODULE FOR BACNET MS/TP (VERIFY WITH OWNER), CONFIGURABLE ANALOG AND DIGITAL I/O.
 - DIRECT COUPLED MOTOR
 - SINGLE STAGE IMPELLER
 - FLANGED CONNECTION
 - 3-SPEED MOTOR
 - BUILT-IN DIFFERENTIAL-PRESSURE AND TEMPERATURE SENSOR
 - STAINLESS STEEL IMPELLER.
- REMARKS:
- SUPPORT PIPING SEPARATELY FROM PUMP
 - REFERENCE SEQUENCE OF OPERATION FOR PUMP CONTROLS
 - INTERLOCK WITH BOILER MASTER CONTROLLERS

AIR SEPARATOR SCHEDULE														
TAG	MANUFACTURER	MODEL NO.	AREA SERVED	WATER				DIMENSIONS				OPER WEIGHT (LBS)	ACCESSORIES	REMARKS
				FLOW (GPM)	HEAD (FT)	VELOCITY (FPS)	GLYCOL (%)	INLET (IN)	OUTLET (IN)	DIA (IN)	H (IN)			
AS-1	CALEFFI	NA546100AM	BLDG. HEATING	150	0.6	4.0	30	4	4	8.6	34.5	150	ALL	ALL

- REMARKS:
- BOTTOM OF SEPARATOR AT 120 INCH ABOVE FINISHED FLOOR
- ACCESSORIES:
- EPOXY COATED STEEL CONSTRUCTION SS INTERNAL ELEMENT.
 - COALESCING MAGNETIC AIR DIRT SEPARATOR.
 - PROVIDE WITH INTEGRAL STRAINER.
 - BRASS BOTTOM DRAIN VALVE AND AUTO AIR VENT.
 - FLANGED CONNECTION.

HEATING WATER EXPANSION TANK SCHEDULE																		
TAG	MANUFACTURER	MODEL	AREA SERVED	MAXIMUM ACCEPTANCE VOLUME (GAL)	TOTAL TANK VOLUME (GAL)	FILL TEMP. (F)	MAX. TEMP. (F)	PRECHARGE TANK PRESSURE (PSIG)	SYSTEM FILL PRESSURE (PSIG)	MAXIMUM SYSTEM PRESSURE (PSIG)	% GLYCOL (%PG)	DIMENSIONS			SHIP WEIGHT (LBS)	OPER WEIGHT (LBS)	ACCESSORIES	REMARKS
												HIEGHT (IN)	DIAMETER (IN)	TANK CONNECTION (IN)				
ET-2	AMTROL	EXTROL 600-L	HEATING WATER	150	150	50	180	15	18	75	30	64	24	1 1/2	510	1837	ALL	ALL

- ACCESSORIES:
- BRASS AIR CHARGE FITTING.
 - FLOOR STAND.
 - VERTICAL TANK ORIENTATION
 - FULL ACCEPTANCE BLADDER.
 - ASME STEEL SHELL WITH RED OXIDE PRIMER.
 - 150 PSIG MAXIMUM WORKING PRESSURE.
- REMARKS:
- SUPPORT TANK FROM FLOOR SUPPORT STAND. LOCATE ON HOUSEKEEPING PAD
 - TANK PRE-CHARGE PRESSURE TO MATCH SYSTEM FILL PRESSURE, FIELD VERIFY PRIOR TO SYSTEM START UP.



CITY AND COUNTY OF BROOMFIELD
 DETENTION CENTER
 HW-DHW PLANT RENOVATION
 11600 RIDGE PKWY, BROOMFIELD, CO 80021

ISSUE/REVISION	DATE	NO.
100% CDS	05/09/22	
ASI #1	06/13/22	
ASI #2	03/26/24	

MECHANICAL SCHEDULES

DRAWN BY	JMB
DESIGN BY	JMB
CHK'D BY	KAM

THIS DOCUMENT, INCLUDING ALL IDEAS AND DESIGNS, IS THE PRODUCT OF 20/20 ENGINEERING, INC. WHO HAS PROVIDED A PROFESSIONAL DESIGN SERVICE AND CANNOT BE USED OR DUPLICATED IN WHOLE OR IN PART BY ANY OTHER PARTY FOR PERMIT, BIDDING OR INSTALLATION PURPOSES FOR THIS OR ANY OTHER PROJECT WITHOUT THE WRITTEN AUTHORIZATION OF 20/20 ENGINEERING, INC. COPYRIGHT 2024.

SHEET NUMBER:

MP1.3

SEQUENCE OF OPERATION:

BROOMFIELD DETENTION CTR- HW/DHW PLANT RENOVATION

1. GENERAL SYSTEM REQUIREMENTS

- 1.1 The heating plant control and basic I/O control point interlock will be coordinated from two factory installed microprocessor controllers on the new boilers (Aerco or approved equivalent) with preprogrammed settings. BACnet com cards supplied with the boilers and secondary loop heating water pumps will communicate with the building management system (BMS) via BACnet MS/TP for system monitoring/trending and basic I/O setpoint management/scheduling.
- 1.2 The domestic water plant control shall be standalone with a Tekmar pump sequencer, factory network control of boiler staging, and BAS point monitoring of EMV-1 and (E) EMV-2 via a Modbus to BACnet gateway.
- 1.3 The Temperature Control Contractor shall provide control function on drawings to include plans, wiring diagrams, and control component bill of materials to accomplish the control sequence described herein.
- 1.4 It is the intent of this control sequence to describe the performance requirements of the system. Therefore, the sequence describes the operational function of the system with minimal requirements for equipment to accomplish these functions.
- 1.5 It is the Temperature Control Contractors responsibility to provide a complete and working system, fully integrated with the owners BAS and ready for the Owners beneficial usage.
- 1.6 The comfort control sequences shall be overridden by any control required for fire/smoke protection as specified here or as required by applicable codes.
- 1.7 The operator shall be able to adjust all program parameters and time, time intervals, temperature, pressure, pressure differential and all other control variable setpoints.
- 1.8 Activation of any equipment alarm shall stop the respective item of equipment and any related equipment that could be damaged. It shall be possible to re-start the equipment only after the cause of the alarm has been investigated and resolved, and after the alarm has been either manually or automatically reset via the BMS, except as defined herein.
 - A Safety alarms/stops shall include, but are not limited to:
 - B Priority shut down. Initiated by the fire/smoke detector, alarm system, and/or BMS.
 - C Boiler Failure.
 - D Secondary HW loop pump failure.
 - E Domestic water pump failure (prediction via heat call).

2. DESIGN INTENT

- 2.1 The space heating requirements for this project will be served by two condensing natural gas fired boilers. The hydraulic heating (HW) system shall have a primary loop and a secondary loop. The primary loop shall have the following components:
 - A Two (2) modulating natural gas fired condensing boilers.
 - B Two (2) primary constant volume in-line pumps. One (1) serving each boiler.
 - C Pipe temperature sensor on primary supply piping header.
- 2.2 The secondary loop shall have the following components:
 - A Two (2) secondary variable speed in-line pumps. Each sized for 50% system load and piped in parallel.
 - B Pipe temperature sensor on secondary supply piping header.
- 2.3 The domestic water heating (DHW) for this project shall be served by multiple DHW heaters, parallel storage tanks, and two electronic mixing valves. This system shall have the following components:
 - A Eight (8) mod-con water heaters.
 - B Two (2) storage tanks.
 - C Two (2) constant volume in-line DHW pumps.
 - D Two (2) electronic mixing valves.
 - E Three (3) constant volume domestic water recirculation pumps.

3. EQUIPMENT

- 3.1 OWNERS BAS
 - A The BAS will communicate via BACnet MS/TP and provide heating plant enable status to secondary loop HW pump manager controller. The heating plant shall be enabled upon call of heat from any terminal device.
 - B The BAS shall monitor all main control points and alarms of the controllers for B-1,2, SP-1,2, EMV-1,2.
 - C Temperature control contractor shall coordinate with Owner for I/O point display graphics and trending. Include up to 30 points graphic displays and 20 point trends.
- 3.2 HW PLANT (B-1, B-2, PP-1, PP-2, SP-1, SP-2)
 - A The BAS will communicate heating plant enable to the secondary loop pumps SP-1,2 upon a call for heat from any terminal HW device. SP-1,2 status (on, no alarm) shall be hard wired relayed to the manager boiler control input of call of enable heating.
 - B SP-1,2 shall communicate and twin locally and adjust their enable lead/lag status and speed for a combined maximum pump efficiency under their internal proportional control strategy. Pumps shall have local S/R temperature and S/R pressure sensors wired/integrated into the pump controller for differential control options. Pumps shall rotate lead status for equal run-time.
 - C PP-1,2 enable shall be hard wired via isolation relay to their respective boiler controllers and run three minute heat purge delays.
 - D Secondary loop HW supply water temperature setpoint (140-90F) and the outdoor air temperature (0F-50F) reset shall be programmed into the manager boiler controller. OAT wired to manager boiler controller.
 - E Boilers shall stage (cascade) and modulate fire rates at combined maximum thermal efficiency to maintain the secondary loop supply water temperature.
 - F Boilers shall rotate lead staging for equal runtime.
- 3.3 DHW PLANT (WH-1 to 8, WHP-1,2, ST-1,2, EMV-1,2, RCP-1,2,3)
 - A Instantaneous water heaters 1 to 8 operate in parallel and shall enable and modulate automatically based off factory controls to maintain a leaving water temperature of 150F.
 - B The lead storage tank shall be the tank which commonly discharges faster than the lag tank. Each tank shall have an aquastat with adjustable setpoint and differential. Lead tank aquastat setpoint = 140F, diff = 10F. Lag tank aquastat setpoint = 125F, diff = 10F.
 - C A stand-alone, Tekmar M4 132 pump sequencer shall enable WHP-1,2 in lead/lag staging with equal run time rotation. Demand1 call from the lead ST aquastat, Demand2 call from the lag ST aquastat. Flow or diff-P switch shall be interlocked with the pump controller as proof of Demand1 flow.
 - D EMV-1 (2009 BLDG EXP.) shall have supply and recirc temp sensors, modulate to maintain a supply temperature of 110F.
 - E EMV-2 (ORIGINAL BLDG) shall have supply and recirc temp sensors, modulate to maintain a supply temperature of 110F.
 - F RCP-1 (110F, 2009 BLDG EXP.): Pump shall operate continuously.
 - G RCP-2 (110F, ORIGINAL BLDG): Pump shall operate continuously.
 - H RCP-3 (140F, ORIGINAL BLDG): Enable pump from HWC pipe mounted aquastat. 130F setpoint, 10F differential.

END OF SEQUENCE

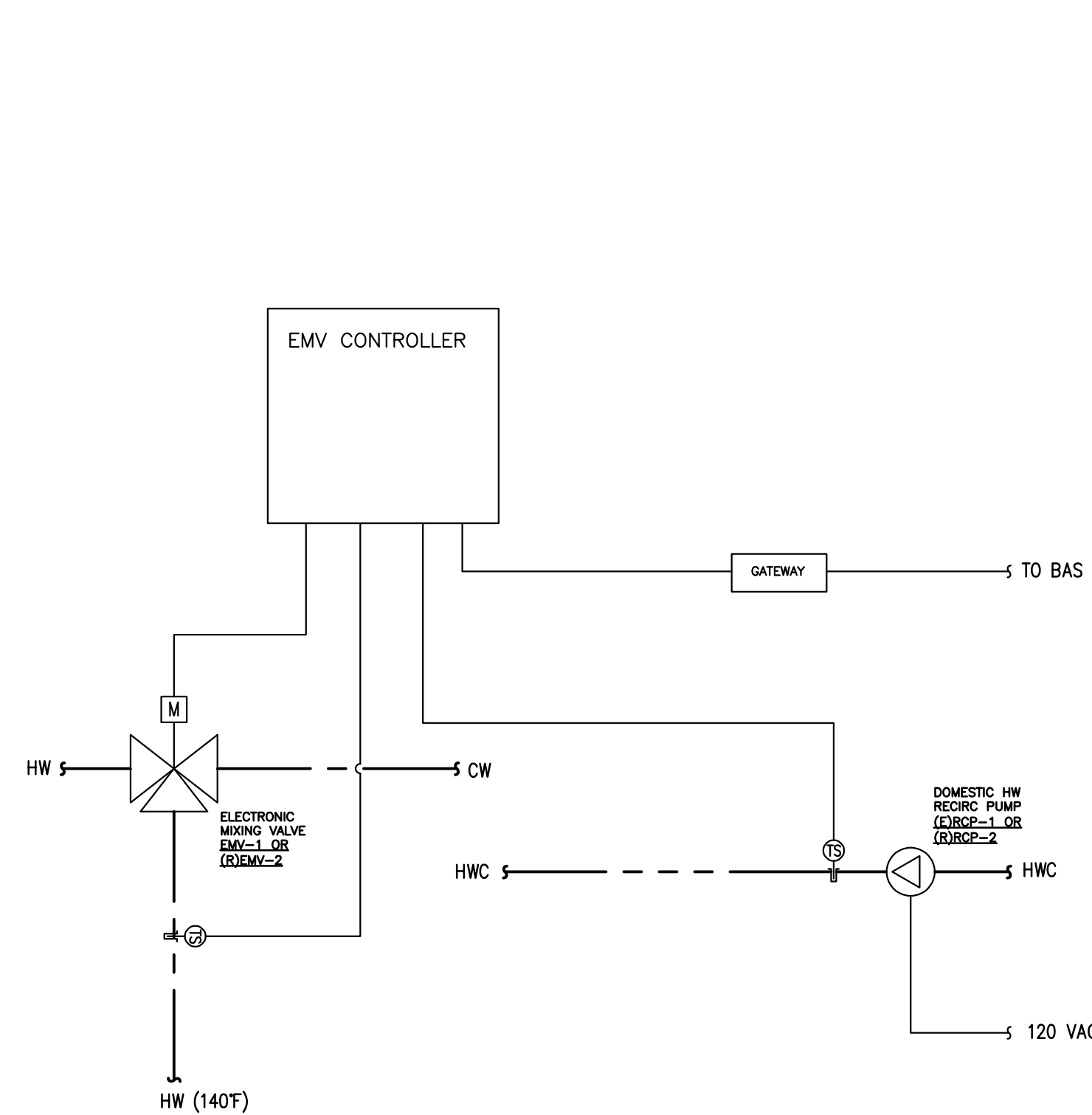

3 EMV CONTROL SCHEMATIC
MP1.4 SCALE: NONE

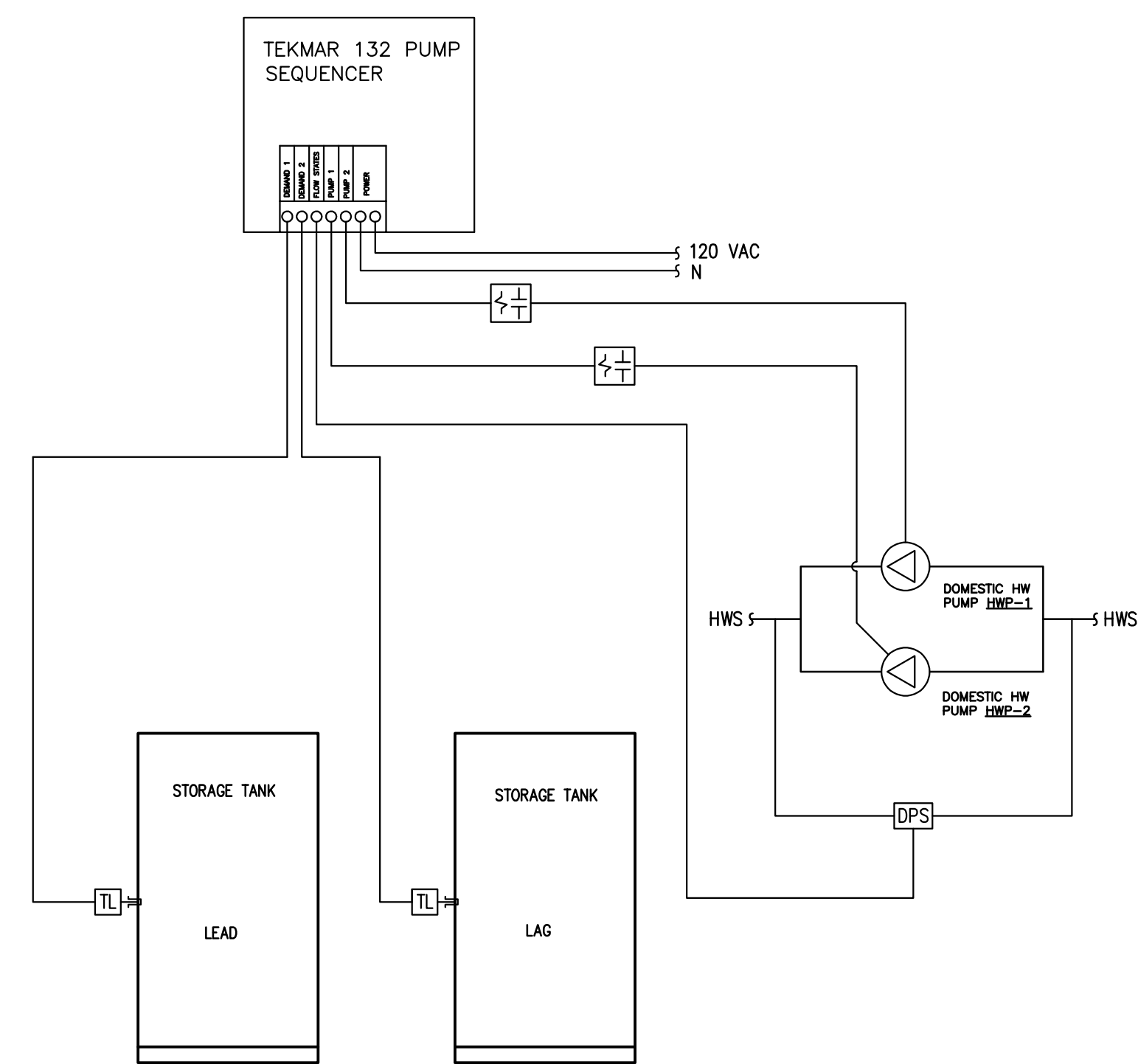

2 DHW PUMP CONTROL SCHEMATIC
MP1.4 SCALE: NONE

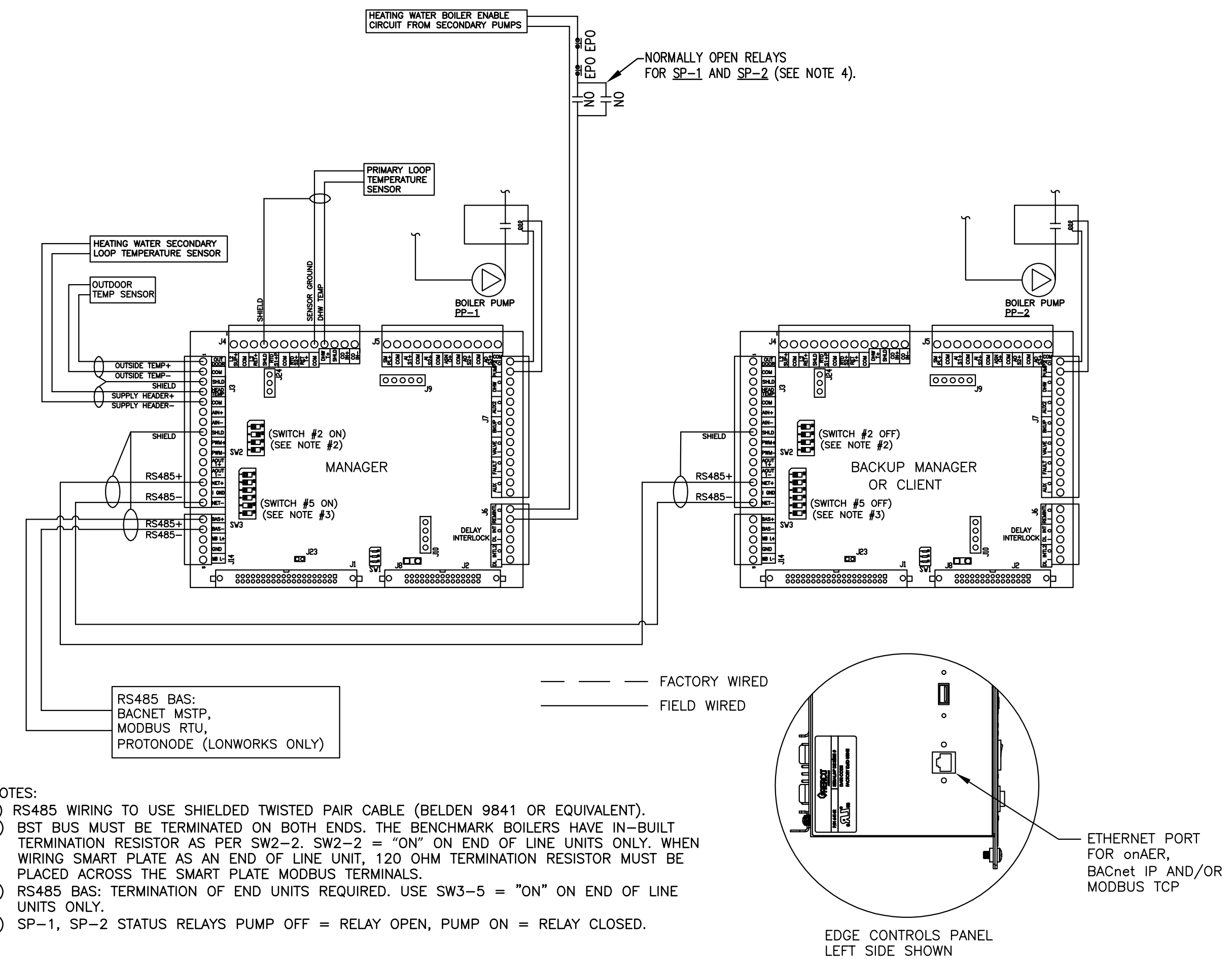

- NOTES:**
- 1) RS485 WIRING TO USE SHIELDED TWISTED PAIR CABLE (BELDEN 9841 OR EQUIVALENT).
 - 2) BST BUS MUST BE TERMINATED ON BOTH ENDS. THE BENCHMARK BOILERS HAVE IN-BUILT TERMINATION RESISTOR AS PER SW2-2. SW2-2 = "ON" ON END OF LINE UNITS ONLY. WHEN WIRING SMART PLATE AS AN END OF LINE UNIT, 120 OHM TERMINATION RESISTOR MUST BE PLACED ACROSS THE SMART PLATE MODBUS TERMINALS.
 - 3) RS485 BAS: TERMINATION OF END UNITS REQUIRED. USE SW3-5 = "ON" ON END OF LINE UNITS ONLY.
 - 4) SP-1, SP-2 STATUS RELAYS PUMP OFF = RELAY OPEN, PUMP ON = RELAY CLOSED.

1 BOILER CONTROL SCHEMATIC
MP1.4 SCALE: NONE



**CITY AND COUNTY OF BROOMFIELD
DETENTION CENTER
HW-DHW PLANT RENOVATION
11600 RIDGE PKWY, BROOMFIELD, CO 80021**

ISSUE/REVISION	DATE	NO.
100% CDS	05/09/22	
ASI #1	06/13/22	
ASI #2	03/26/24	

**MECH./PLUMB.
SEQUENCE OF OP.**

DRAWN BY	JMB
DESIGN BY	JMB
CHK'D BY	KAM

THIS DOCUMENT, INCLUDING ALL IDEAS AND DESIGNS, IS THE PROPERTY OF 20/20 ENGINEERING, INC. WHO HAS PROVIDED A PROFESSIONAL DESIGN SERVICE AND CANNOT BE USED OR REPRODUCED IN WHOLE OR IN PART BY ANY OTHER PARTY FOR PERMIT, BIDDING OR INSTALLATION PURPOSES FOR THIS OR ANY OTHER PROJECT WITHOUT THE WRITTEN AUTHORIZATION OF 20/20 ENGINEERING, INC. COPYRIGHT © 2024.

SHEET NUMBER:

MP1.4

20/20 PROJECT # 22020



CITY AND COUNTY OF BROOMFIELD
DETENTION CENTER
HW-DHW PLANT RENOVATION
11600 RIDGE PKWY, BROOMFIELD, CO 80021

GENERAL NOTES:

- A. CONTRACTOR TO FIELD-VERIFY ALL EXISTING CONDITIONS PRIOR TO COMMENCEMENT OF WORK.
- B. CONTRACTOR TO DEMO ALL EXISTING POWER FROM EXISTING PANELS HPP AND HEM AND USE CORRESPONDING POWER IN NEW PLANS.

SHEET NOTES:

- 1 DEMO EXISTING HEATING WATER EQUIPMENT, ALL CONNECTED HWS/R PIPING, VALVES AND FITTINGS.
- 2 DEMO EXISTING CONTROLS AND POWER WIRING BACK TO PANEL.
- 3 EXISTING BOILER HOUSEKEEPING PAD TO REMAIN. REPAIR ANY DAMAGE AS NEEDED.
- 4 DEMO EXISTING BOILER FLUE. ROOF OPENING TO REMAIN FOR NEW BOILER VENT RISERS.
- 5 DEMO EXISTING BOILER FLUE. GC SHALL PATCH, REPAIR, AND SEAL EXISTING OPENING.
- 6 EXISTING LOUVER AND PLENUM SHALL REMAIN FOR FUTURE BOILER COMBUSTION AIR CONNECTION. SEAL AT EXISTING CONNECTION AS NEEDED.
- 7 DEMO EXISTING BOILER COMBUSTION AIR DUCT AND ASSOCIATED DAMPER.
- 8 EXISTING EXHAUST DUCTS AND ASSOCIATED FANS TO REMAIN.
- 9 EXISTING UNIT HEATER AND ASSOCIATED PIPING TO REMAIN.
- 10 EXISTING GYCOL FEEDER, POT FEEDER, AND SYSTEM TO REMAIN (OR BE RELOCATED, IF NECESSARY).
- 11 EXISTING PIPING TO REMAIN FOR FUTURE CONNECTION.
- 12 DEMO EXISTING EXPANSION TANK AND ALL CONNECTED PIPING, VALVES, AND FITTINGS.
- 13 DEMO EXISTING DOMESTIC HEATING WATER EQUIPMENT, ALL CONNECTED CW/HW/HWC PIPING, VALVES AND FITTINGS.
- 14 DEMO EXISTING CA DUCT AND EA DUCT. GC SHALL PATCH, REPAIR, AND SEAL EXISTING OPENING.
- 15 DEMO EXISTING WATER HEATER FLUE. GC SHALL PATCH, REPAIR, AND SEAL EXISTING OPENING.
- 16 DEMO EXISTING COMBUSTION AIR FAN.
- 17 DEMO EXISTING THERMOSTATIC MIXING VALVE. DEMO BACK CW/HW/HWC PIPING BACK TO LOCATIONS SHOWN.
- 18 ELECTRIC UNIT HEATER TO REMAIN AS-IS.
- 19 PLUMBING FIXTURE TO REMAIN AS-IS.
- 20 DOMESTIC HOT WATER RECIRCULATION PUMPS TO BE RELOCATED. RE: SHEET MP3.0.
- 21 DIGITAL THERMOSTATIC MIXING VALVE TO BE RELOCATED. RE: SHEET MP3.0.
- 22 DEMO CONTROLS/STARTERS FROM ASSOCIATED DEMO'D PUMPS.
- 23 DEMO EXISTING BOILER HOUSEKEEPING PAD. GC SHALL REPAIR FLOOR TO MATCH SURROUNDING FLOOR.
- 24 DEMO HWS/R PIPING BACK TO THIS LOCATION.
- 25 DEMO CW/HW/HWC PIPING BACK TO THIS LOCATION.
- 26 DEMO NATURAL GAS PIPING BACK TO PRV.
- 27 DEMO NATURAL GAS PIPING BACK TO LOCATION SHOWN.

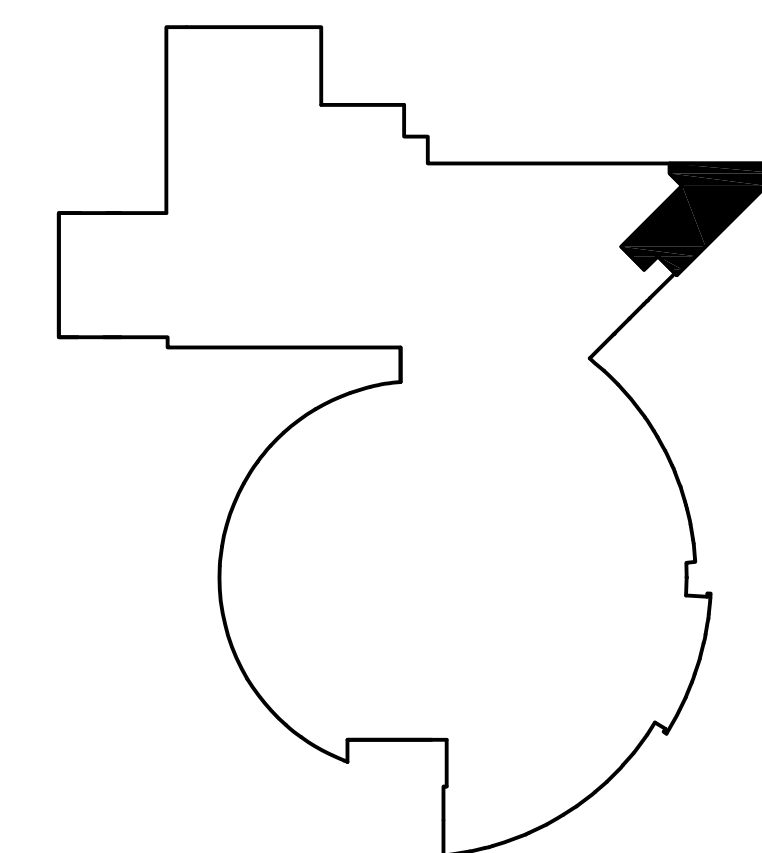
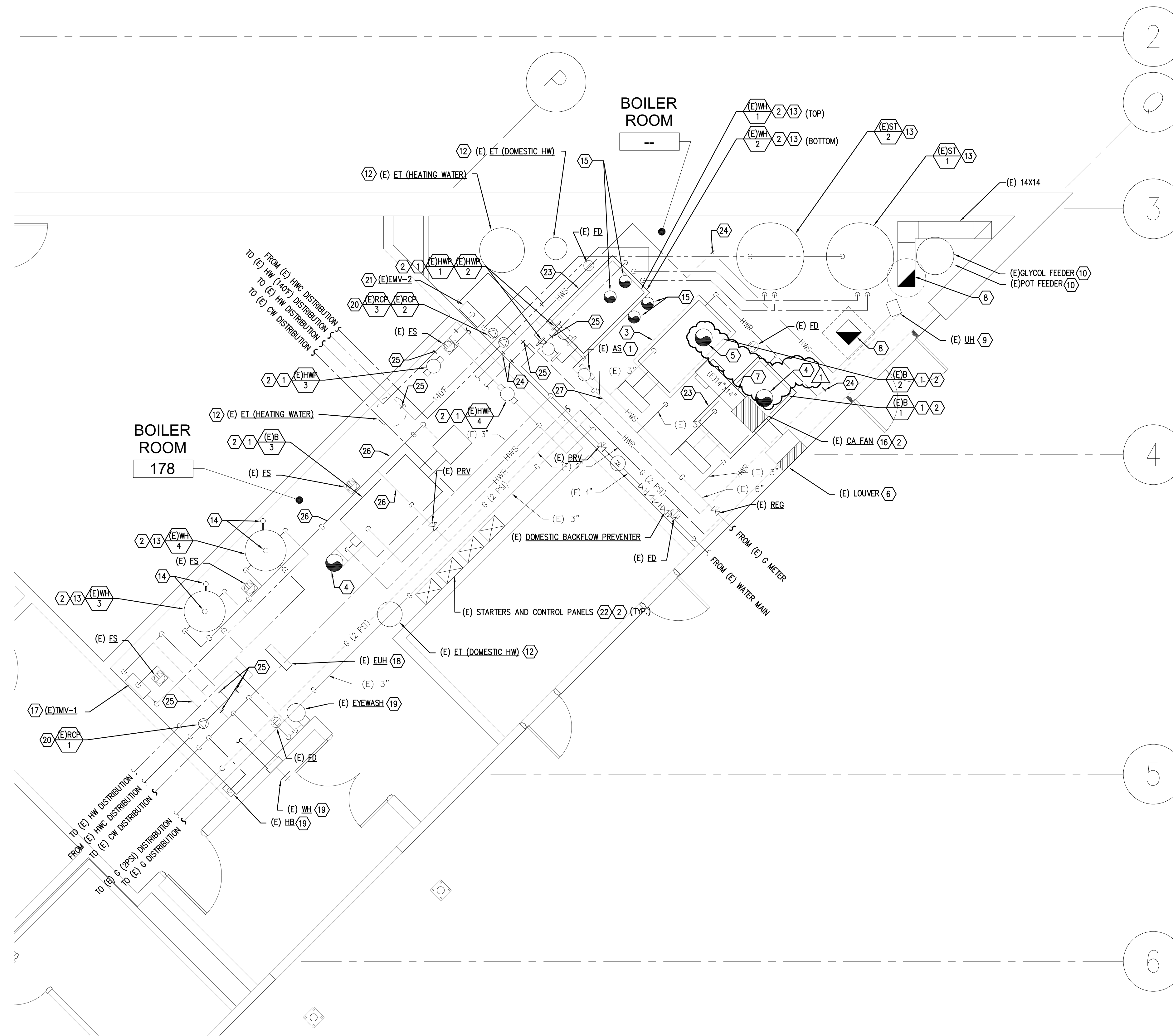

KEY PLAN
SCALE: NONE

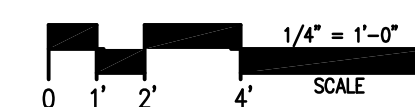

MECHANICAL/PLUMBING DEMOLITION PLAN
MP2.0 SCALE: 1/4" = 1'-0"



ISSUE/REVISION	DATE	NO.
100% CDS	05/09/22	
ASI #1	06/13/22	1
ASI #2	03/26/24	2

**MECH/PLUMB
DEMOLITION PLAN**

DRAWN BY	JMB
DESIGN BY	JMB
CHK'D BY	KAM

THIS DOCUMENT, INCLUDING ALL IDEAS AND DESIGNS, IS THE PROPERTY OF 20/20 ENGINEERING, INC. WHO HAS PROVIDED A PROFESSIONAL DESIGN SERVICE AND CANNOT BE USED OR REPRODUCED IN WHOLE OR IN PART BY ANY OTHER PARTY FOR PERMIT, BIDDING OR INSTALLATION PURPOSES FOR THIS OR ANY OTHER PROJECT WITHOUT THE WRITTEN AUTHORIZATION OF 20/20 ENGINEERING, INC. COPYRIGHT © 2024.

SHEET NUMBER:

MP2.0

20/20 PROJECT # 22020



CITY AND COUNTY OF BROOMFIELD
DETENTION CENTER
HW-DHW PLANT RENOVATION
11600 RIDGE PKWY, BROOMFIELD, CO 80021

GENERAL NOTES:

- A. CONTRACTOR TO FIELD-VERIFY ALL EXISTING CONDITIONS PRIOR TO COMMENCEMENT OF WORK.
- B. ALL COPPER/IRON PIPING TRANSITIONS TO BE BRONZE NIPPLES OR COUPLINGS.
- C. REFER TO PIPING SCHEMATICS FOR ALL COMPONENT SIZES, VALVES, AND FITTINGS.

SHEET NOTES:

- 1 EXISTING FLUE OPENING. ROUTE NEW BOILER VENTS UP THROUGH OPENING. GC SHALL PATCH AND SEAL OPENING AROUND NEW VENTS.
- 2 EXISTING GLYCOL FEEDER AND POT FEEDER SYSTEMS TO REMAIN. CONNECT TO NEW PIPING. RE: HEATING WATER SCHEMATIC
- 3 CONNECT NEW LOUVER PLENUM TO EXISTING LOUVER AND CONNECT NEW BOILER AND WATER HEATER COMBUSTION AIR DUCTS.
- 4 6" CA DUCT DOWN TO BOILER.
- 5 6" EA DUCT DOWN TO BOILER.
- 6 CONNECT (N) HWS/R PIPING TO (E) HWS/R PIPING AT THIS LOCATION. FIELD-VERIFY LOCATION AND DIMENSIONS PRIOR TO INSTALLATION AND NOTIFY ENGINEER OF RECORD OF ANY CONFLICTS.
- 7 CONNECT (N) GAS PIPING TO (E) GAS PIPING AT THIS LOCATION. FIELD-VERIFY LOCATION AND DIMENSIONS PRIOR TO INSTALLATION AND NOTIFY ENGINEER OF RECORD OF ANY CONFLICTS.
- 8 CONNECT (N) CW PIPING TO (E) CW PIPING AT THIS LOCATION. FIELD-VERIFY LOCATION AND DIMENSIONS PRIOR TO INSTALLATION AND NOTIFY ENGINEER OF RECORD OF ANY CONFLICTS.
- 9 CONNECT (N) HW PIPING TO (E) HW PIPING AT THIS LOCATION. FIELD-VERIFY LOCATION AND DIMENSIONS PRIOR TO INSTALLATION AND NOTIFY ENGINEER OF RECORD OF ANY CONFLICTS.
- 10 CONNECT (N) HWC PIPING TO (E) HWC PIPING AT THIS LOCATION. FIELD-VERIFY LOCATION AND DIMENSIONS PRIOR TO INSTALLATION AND NOTIFY ENGINEER OF RECORD OF ANY CONFLICTS.
- 11 CONNECT (N) HW (140F) PIPING TO (E) HW (140F) PIPING AT THIS LOCATION. FIELD-VERIFY LOCATION AND DIMENSIONS PRIOR TO INSTALLATION AND NOTIFY ENGINEER OF RECORD OF ANY CONFLICTS.
- 12 INSTALL NEW EPO SWITCH AND BATTERY OPERATED CARBON MONOXIDE DETECTOR ON WALL.
- 13 MANUFACTURER RECOMMENDED SERVICE CLEARANCE (TYP.).
- 14 8" CA COMBINED MANIFOLD UNDER EA MANIFOLD. TRANSITION FROM STEEL PIPE TO FACTORY SUPPLIED PP COMB. AIR WITH ADAPTOR COUPLING.
- 15 4" EA/CA CONCENTRIC VENT DOWN TO INSTANTANEOUS WATER HEATER.
- 16 8" EA COMBINED MANIFOLD UP THROUGH ROOF. TERMINATE PER MANUFACTURER'S RECOMMENDATIONS.
- 17 CONDENSATE NEUTRALIZER.
- 18 CW FILL LINE OVER TO GLYCOL FEEDER.
- 19 INSTALL AIR SEPARATOR HIGH AND CLOSE TO THE WALL.
- 20 MOUNT PUMPS ON FLOOR PUMP STAND.

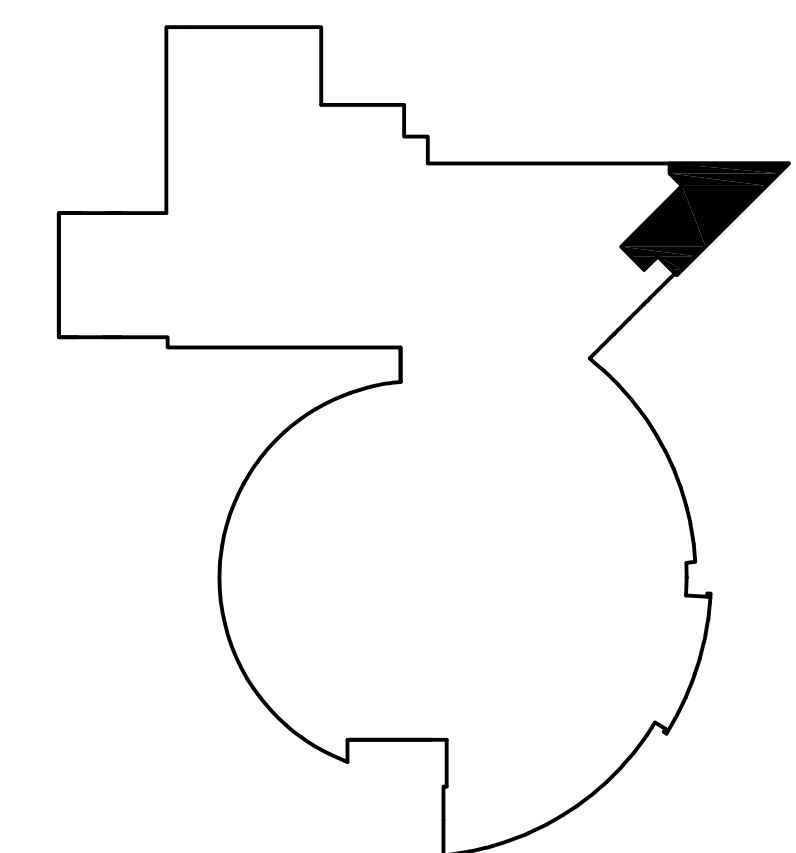
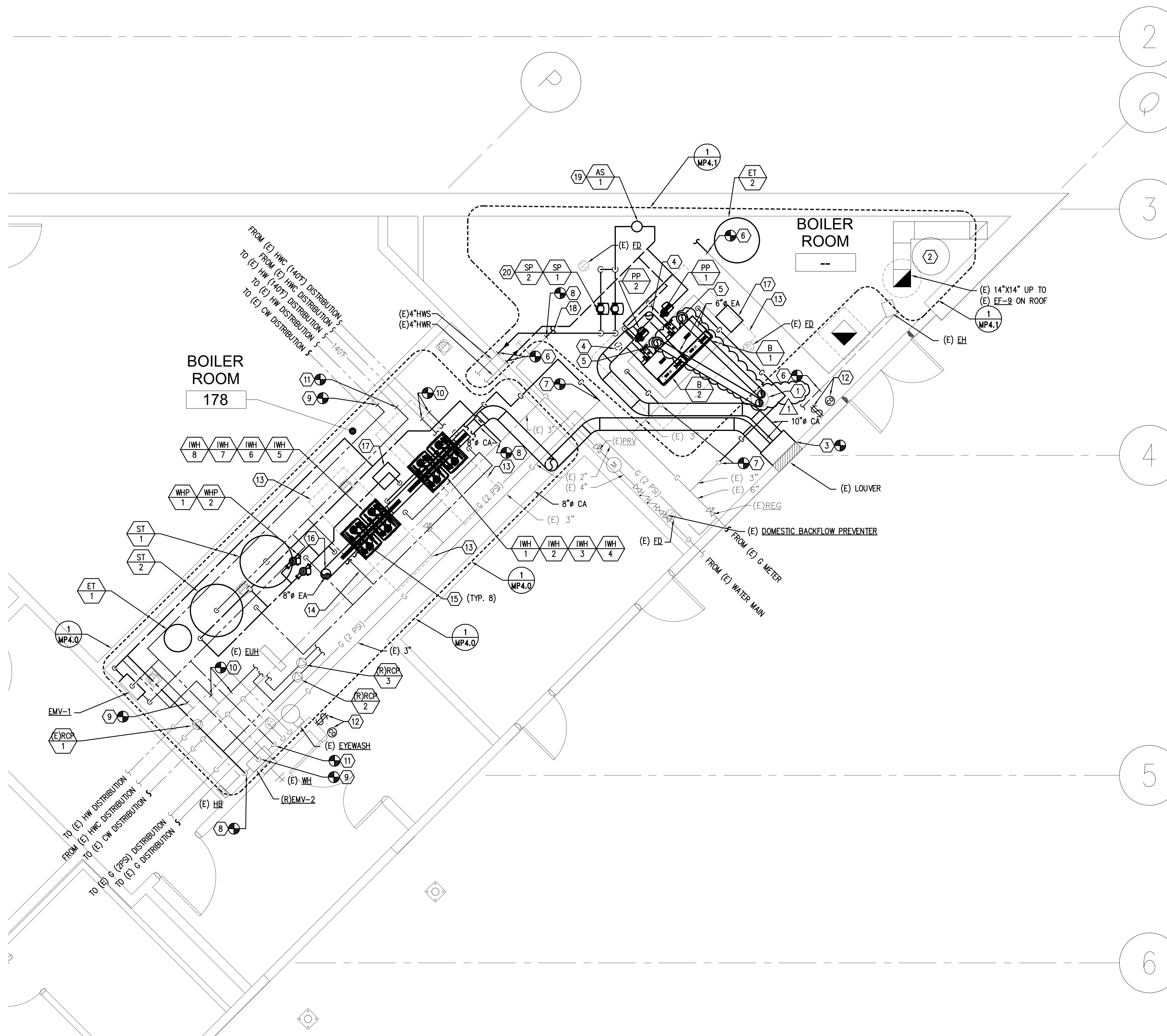

KEY PLAN
SCALE: NONE

MECHANICAL/PLUMBING PLAN
SCALE: 1/4" = 1'-0"

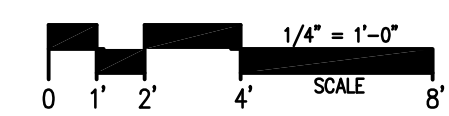
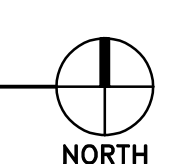

ISSUE/REVISION	DATE	NO.
100% CDS	05/09/22	
ASI #1	06/13/22	1
ASI #2	03/26/24	2

MECH/PLUMB
PLAN

DRAWN BY	JMB
DESIGN BY	JMB
CHK'D BY	KAM

THIS DOCUMENT, INCLUDING ALL IDEAS AND DESIGNS, IS THE PROPERTY OF 20/20 ENGINEERING, INC. WHO HAS PROVIDED A PROFESSIONAL DESIGN SERVICE AND CANNOT BE USED OR REPRODUCED IN WHOLE OR IN PART BY ANY OTHER PARTY FOR PERMIT, BIDDING OR INSTALLATION PURPOSES FOR THIS OR ANY OTHER PROJECT WITHOUT THE WRITTEN AUTHORIZATION OF 20/20 ENGINEERING, INC. COPYRIGHT © 2024.

SHEET NUMBER:
MP3.0
20/20 PROJECT # 22020

GENERAL NOTE:
CONNECTION SIZE FOR GAS, CW,
HW, HWC, AND CONDENSATE PER
MANUFACTURER SPECIFICATIONS

CONTROLS:
REFER TO SHEET MP1.4
FOR CONTROL SCHEMATIC AND
SEQUENCE OF OPERATION

SCHMATIC NOTES:

- ① ANCHOR EXPANSION TANK TO HOUSEKEEPING PAD.
- ② 2" CW OR 2" HW HEADER.
- ③ 1 1/4" GAS HEADER.
- ④ 3/4" CONDENSATE HEADER.
- ⑤ TEKMAR MODEL #132 LEAD-LAG PUMP SEQUENCER.
- ⑥ BALANCE/ISO VALVE, B&G MODEL #CB-2S LF.
- ⑦ LOW LIMIT AQUASTAT TIED TO PUMP.

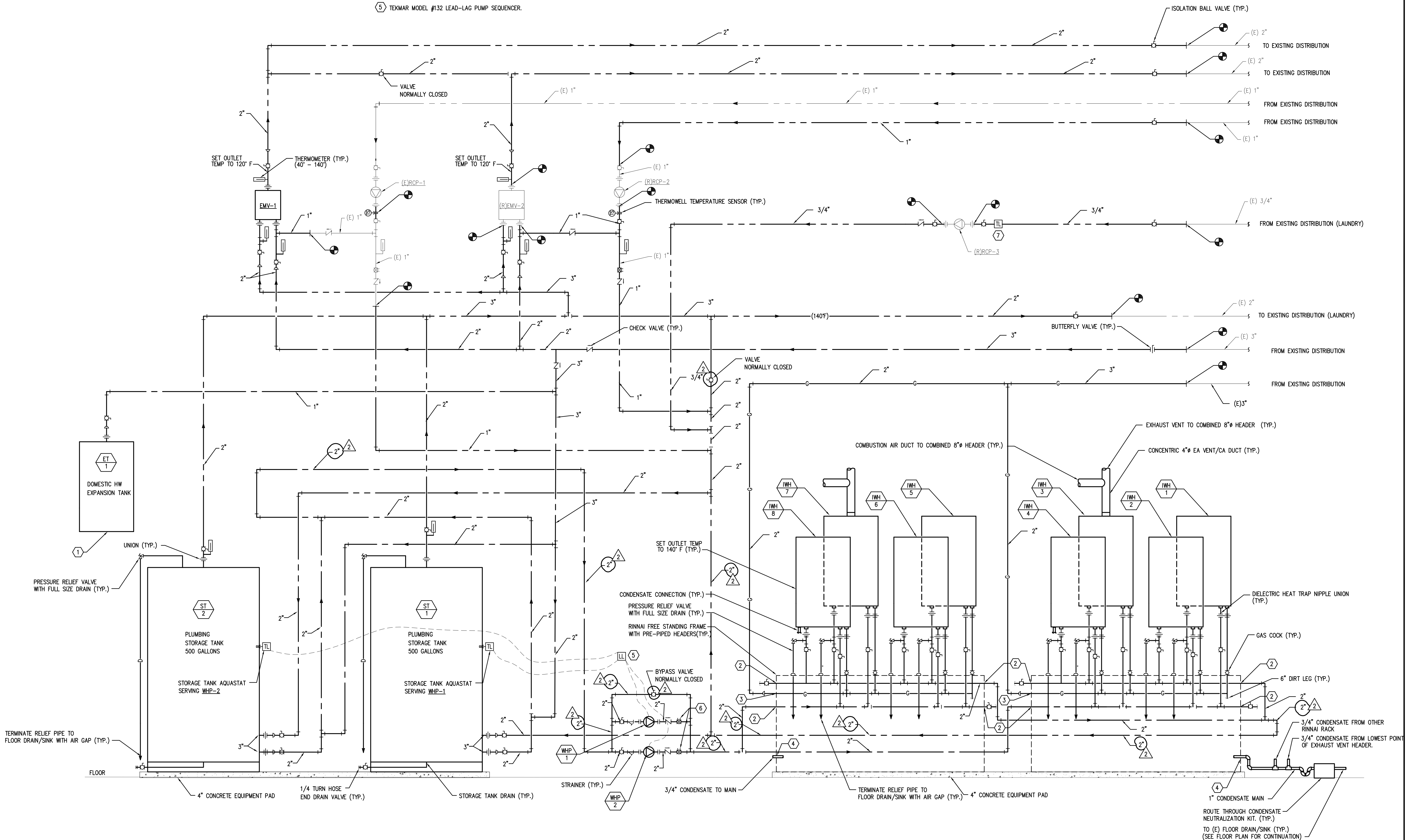

1 DOMESTIC WATER HEATING SCHEMATIC
MP4.0 SCALE: NONE



CITY AND COUNTY OF BROOMFIELD
DETENTION CENTER
HW-DHW PLANT RENOVATION
11600 RIDGE PKWY, BROOMFIELD, CO 80021

ISSUE/REVISION	DATE	NO.
100% CDS	05/09/22	
ASI #1	06/13/22	
ASI #2	03/26/24	

MECHANICAL
DETAILS

DRAWN BY	JMB
DESIGN BY	JMB
CHK'D BY	KAM

THIS DOCUMENT, INCLUDING ALL IDEAS AND DESIGNS, IS THE PROPERTY OF 20/20 ENGINEERING, INC. WHO HAS PROVIDED A PROFESSIONAL DESIGN SERVICE AND CANNOT BE USED OR REPRODUCED IN WHOLE OR IN PART BY ANY OTHER PARTY FOR PERMIT, BIDDING OR INSTALLATION PURPOSES FOR THIS OR ANY OTHER PROJECT WITHOUT THE WRITTEN AUTHORIZATION OF 20/20 ENGINEERING, INC. COPYRIGHT 2024.



CITY AND COUNTY OF BROOMFIELD
DETENTION CENTER
HW-DHW PLANT RENOVATION
11600 RIDGE PKWY, BROOMFIELD, CO 80021

ISSUE/REVISION	DATE	NO.
100% CDS	05/09/22	
ASI #1	06/13/22	
ASI #2	03/26/24	

MECHANICAL
DETAILS

DRAWN BY	JMB
DESIGN BY	JMB
CHK'D BY	KAM

THIS DOCUMENT, INCLUDING ALL IDEAS AND DESIGNS, IS THE PROPERTY OF 20/20 ENGINEERING, INC. WHO HAS PROVIDED A PROFESSIONAL DESIGN SERVICE AND CANNOT BE USED OR REPRODUCED IN WHOLE OR IN PART BY ANY OTHER PARTY FOR PERMIT, BIDDING OR INSTALLATION PURPOSES FOR THIS OR ANY OTHER PROJECT WITHOUT THE WRITTEN AUTHORIZATION OF 20/20 ENGINEERING, INC. COPYRIGHT © 2024.

SHEET NUMBER:

MP4.1

20/20 PROJECT # 22020

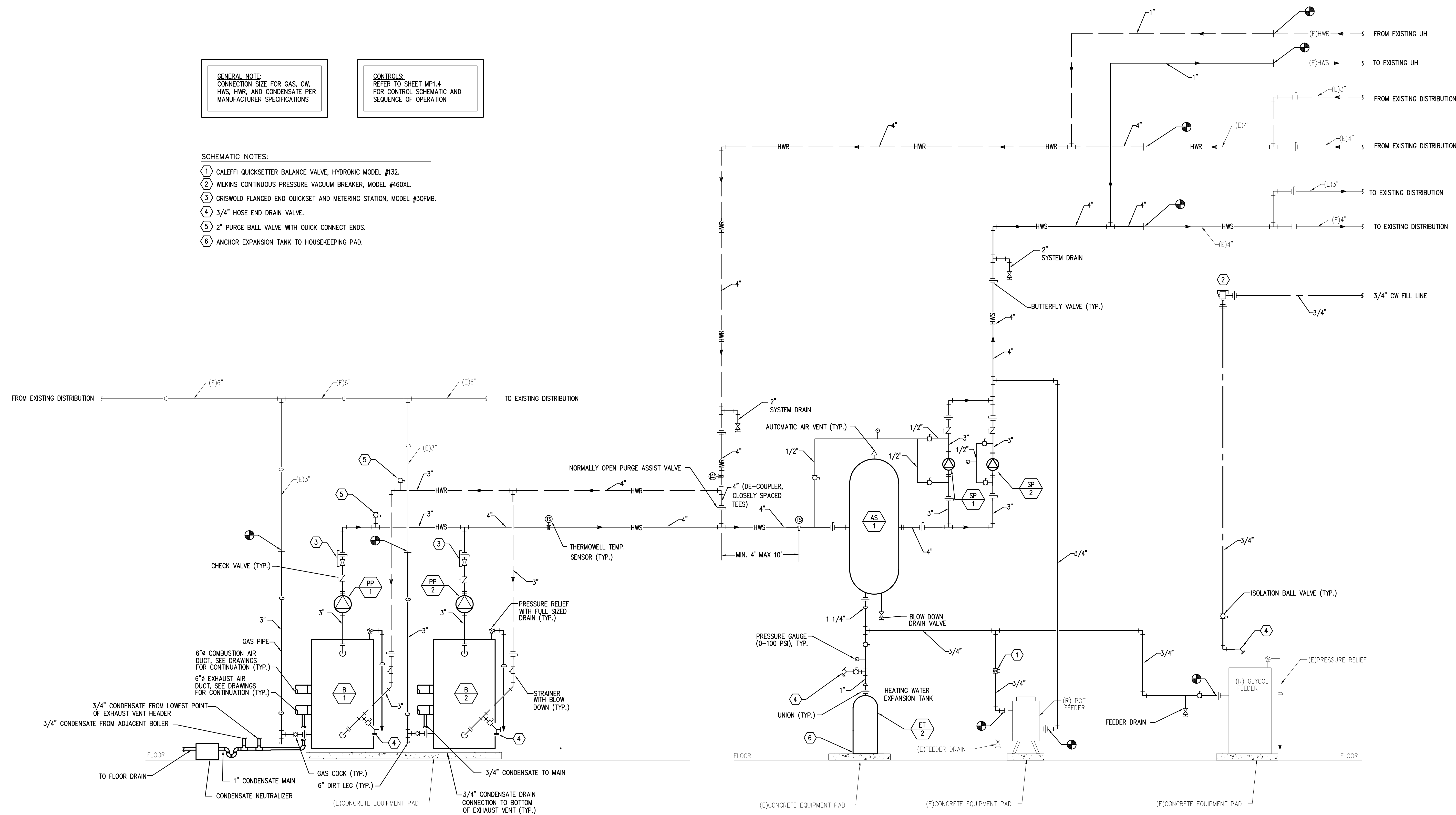

GENERAL NOTE:
CONNECTION SIZE FOR GAS, CW, HWS, HWR, AND CONDENSATE PER MANUFACTURER SPECIFICATIONS

CONTROLS:
REFER TO SHEET MP1.4 FOR CONTROL SCHEMATIC AND SEQUENCE OF OPERATION

- SCHEMATIC NOTES:**
- 1 CALEFFI QUICKSETTER BALANCE VALVE, HYDRONIC MODEL #132.
 - 2 WILKINS CONTINUOUS PRESSURE VACUUM BREAKER, MODEL #460XL.
 - 3 GRISWOLD FLANGED END QUICKSET AND METERING STATION, MODEL #30FMB.
 - 4 3/4" HOSE END DRAIN VALVE.
 - 5 2" PURGE BALL VALVE WITH QUICK CONNECT ENDS.
 - 6 ANCHOR EXPANSION TANK TO HOUSEKEEPING PAD.

1 HEATING WATER SYSTEM SCHEMATIC
SCALE: NONE



CITY AND COUNTY OF BROOMFIELD
DETENTION CENTER
HW-DHW PLANT RENOVATION
11600 RIDGE PKWY, BROOMFIELD, CO 80021

ISSUE/REVISION	DATE	NO.
100% CDS	05/09/22	
ASI #1	06/13/22	
ASI #2	03/26/24	

NATURAL
GAS SCHEMATIC

DRAWN BY	JMB
DESIGN BY	JMB
CHK'D BY	KAM

THIS DOCUMENT, INCLUDING ALL IDEAS AND DESIGNS, IS THE PRODUCT OF 20/20 ENGINEERING, INC. WHO HAS PROVIDED A PROFESSIONAL DESIGN SERVICE AND CANNOT BE USED OR DUPLICATED IN WHOLE OR IN PART BY ANY OTHER PARTY FOR PERMIT, BIDDING OR INSTALLATION PURPOSES FOR THIS OR ANY OTHER PROJECT WITHOUT THE WRITTEN AUTHORIZATION OF 20/20 ENGINEERING, INC. COPYRIGHT © 2024.

SHEET NUMBER:

MP4.2

20/20 PROJECT # 22020

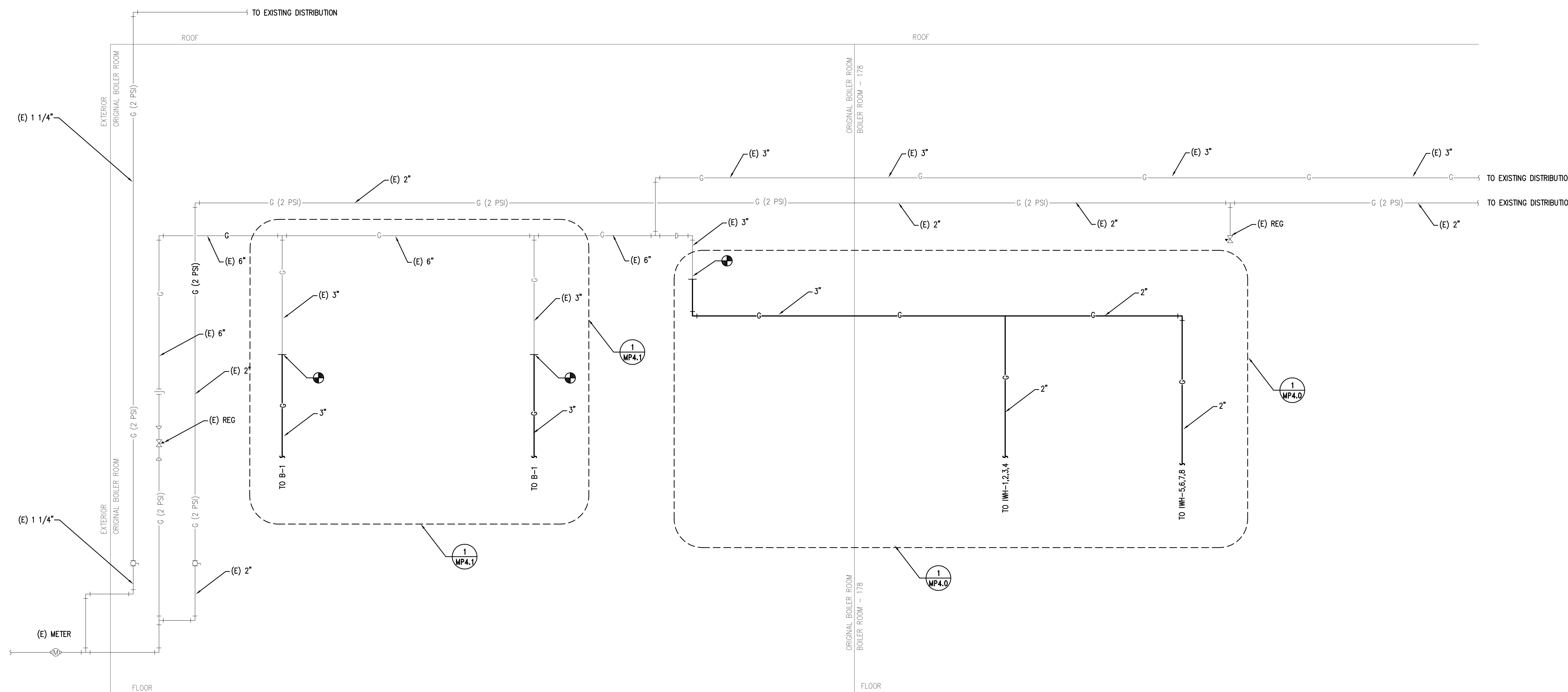

1 NATURAL GAS PIPING SCHEMATIC
SCALE: NONE

TEMPORARY PIPING GENERAL NOTES:

1. TEMPORARY PIPING MATERIAL SPECIFICATION

1.1 PIPING SYSTEM ABBREVIATIONS

A. TEMP: Temporary Domestic Water Piping

1.2 PIPING AND FITTING MATERIALS

A. All piping, gaskets, and fittings shall be constructed, certified and labeled where applicable, and joined as recognized by ASTM, NSF, or ASME standards applicable to the material and application.

B. Type K hard drawn copper tubing with soldered joints, 95 percent tin / 5 percent antimony lead-free solder and wrought-copper fittings OR copper press-connect pressure fittings compliant with ASME B16.51-2018 / IAPMO PS117-2017.

I. TEMP.

C. Type L hard drawn copper tubing with soldered joints, 95 percent tin / 5 percent antimony lead-free solder and wrought-copper fittings OR copper press-connect pressure fittings compliant with ASME B16.51-2018 / IAPMO PS117-2017.

I. TEMP.

D. Type M copper tubing with wrought copper fittings and 95 percent tin / 5 percent antimony lead-free solder. TEMPORARY TYPE M COPPER PIPING SHALL NOT BE RE-USED FOR ORIGINAL SCOPE OF WORK. RE: GENERAL NOTES ON SHEET M1.1 AND M1.2 FOR PERMANENT DOMESTIC WATER PIPING.

I. TEMP.

E. Cross-linked polyethylene (pe-x) tubing with oxygen barrier, crimp or expansion type fittings, fittings to be made of dezincification resistant material, Pex systems shall be Uponor AquaPEX. TEMPORARY PEX PIPING SHALL NOT BE RE-USED FOR ORIGINAL SCOPE OF WORK. RE: GENERAL NOTES ON SHEET M1.1 AND M1.2 FOR PERMANENT DOMESTIC WATER PIPING.

I. TEMP.

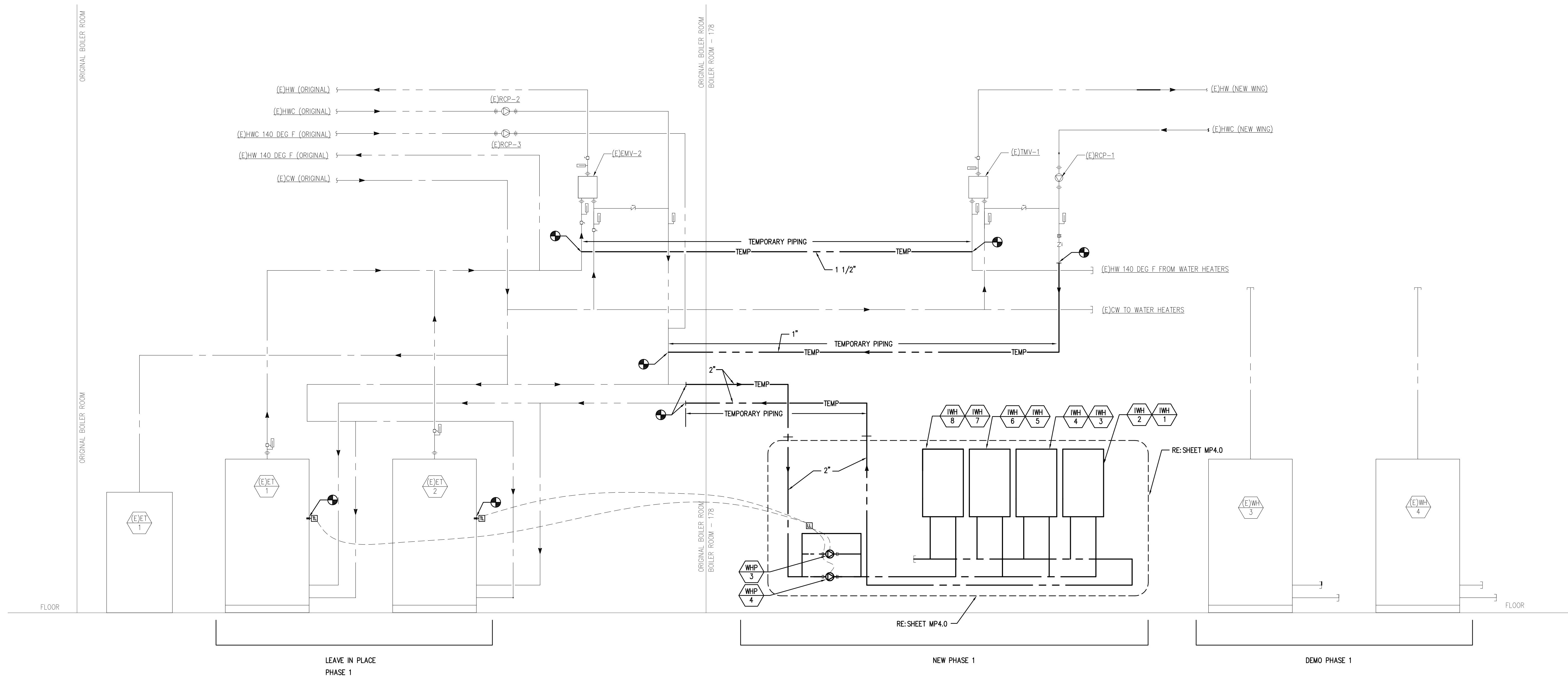

CITY AND COUNTY OF BROOMFIELD
DETENTION CENTER
HW-DHW PLANT RENOVATION
11600 RIDGE PKWY, BROOMFIELD, CO 80021

ISSUE/REVISION	DATE	NO.
100% CDS	05/09/22	
ASI #1	06/13/22	
ASI #2	03/26/24	

DOMESTIC WATER PHASING SCHEMATIC

DRAWN BY	JMB
DESIGN BY	JMB
CHK'D BY	KAM

THIS DOCUMENT, INCLUDING ALL IDEAS AND DESIGNS, IS THE PROPERTY OF 20/20 ENGINEERING, INC. WHO HAS PROVIDED A PROFESSIONAL DESIGN SERVICE AND CANNOT BE USED OR REPRODUCED IN WHOLE OR IN PART BY ANY OTHER PARTY FOR PERMIT, BIDDING OR INSTALLATION PURPOSES FOR THIS OR ANY OTHER PROJECT WITHOUT THE WRITTEN AUTHORIZATION OF 20/20 ENGINEERING, INC. COPYRIGHT 2024



GENERAL NOTES:

- A. CONTRACTOR TO FIELD-VERIFY ALL EXISTING CONDITIONS PRIOR TO COMMENCEMENT OF WORK.
- B. REFER TO CONTROL SEQUENCE OF OPERATION FOR REQUIRED EQUIPMENT INTERLOCKS.
- C. ALL CONDUCTORS MUST BE SOLID CORE, RUN IN METAL CONDUIT AND SIZED PER NEC STANDARDS.
- D. ALL NEW EQUIPMENT SHALL BE PROVIDED WITH DISCONNECTS.
- E. ELECTRICAL CONTRACTOR SHALL BE RESPONSIBLE FOR 120/1 VAC BOILER AND WATER HEATER SAFETY CIRCUITS.

SHEET NOTES:

- ① CONTRACTOR TO VERIFY PANEL WITH OWNER.
- ② BOILER EMERGENCY POWER OFF SWITCH.
- ③ WATER HEATER EMERGENCY POWER OFF SWITCH.
- ④ WALL MOUNTED CARBON MONOXIDE DETECTOR.
- ⑤ EQUIPMENT TO BE ON EMERGENCY POWER, 120 V PANEL. CONTRACTOR TO VERIFY PANEL WITH OWNER.

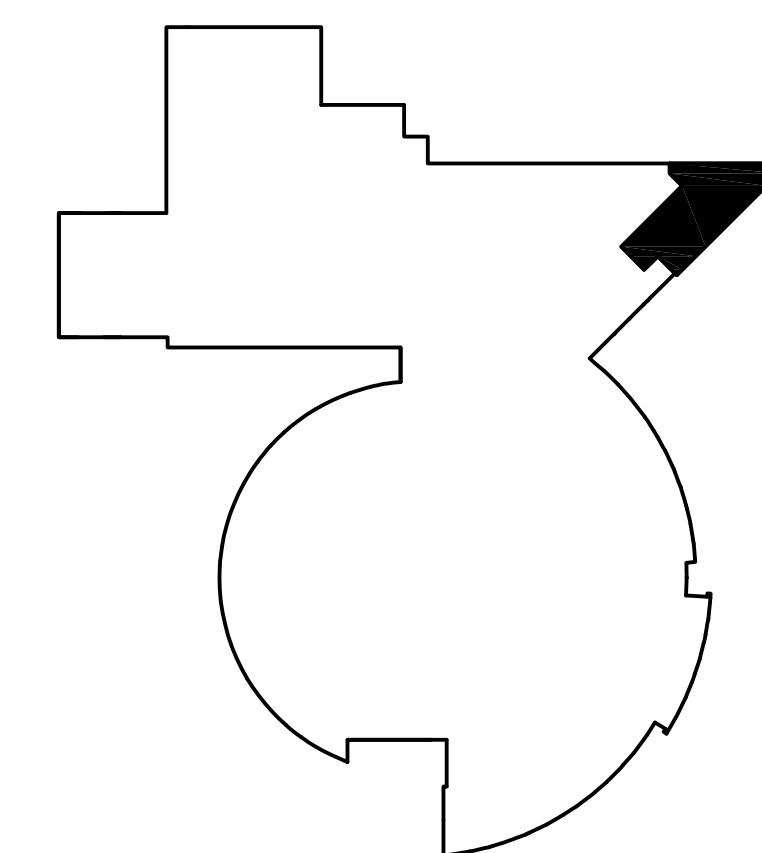
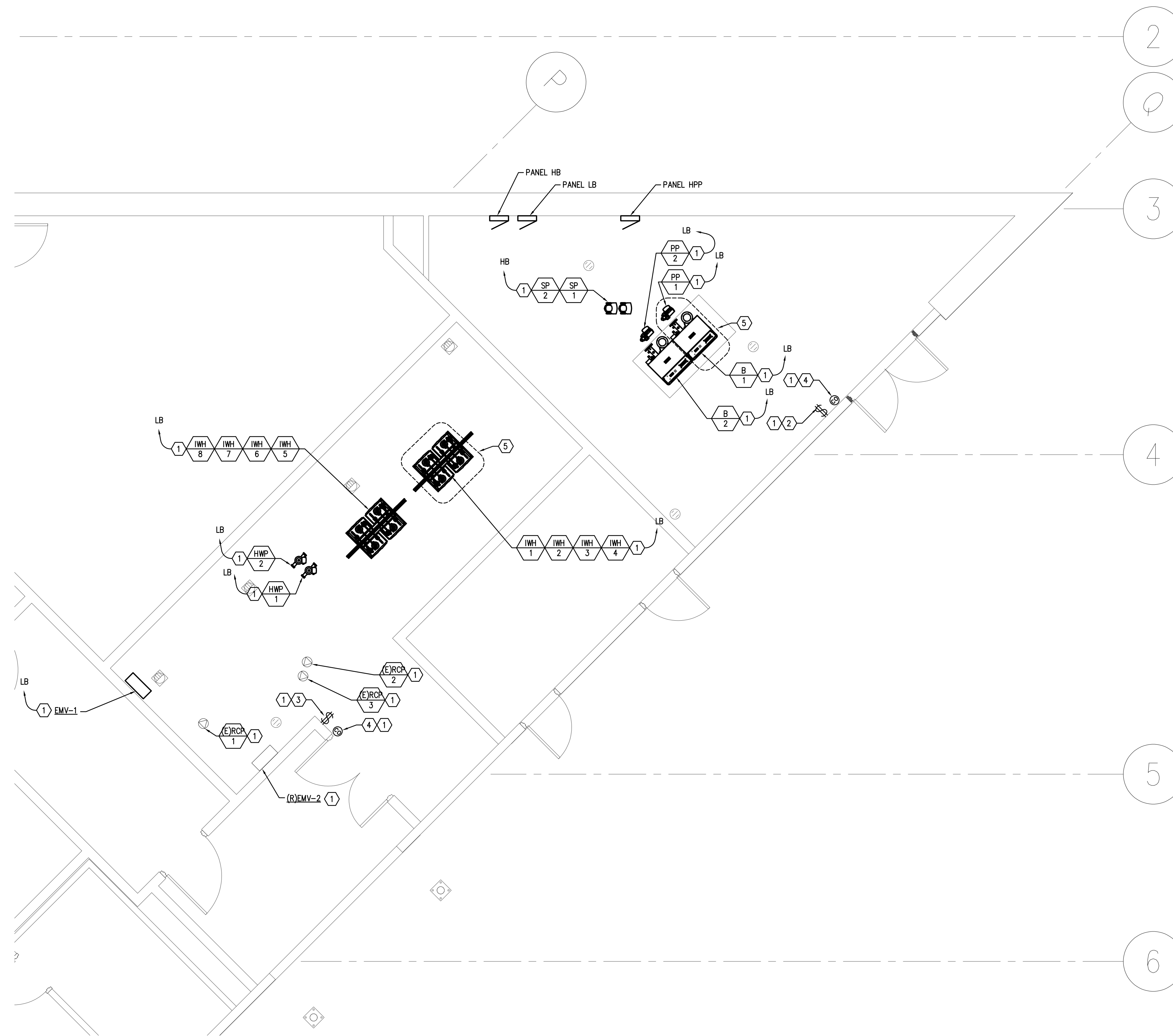

KEY PLAN
SCALE: NONE

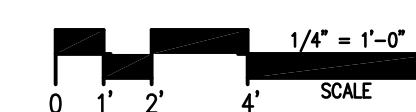

1 BOILER PLAN - ELECTRICAL
ME1.0 SCALE: 1/4" = 1'-0"



CITY AND COUNTY OF BROOMFIELD
DETENTION CENTER
HW-DHW PLANT RENOVATION
11600 RIDGE PKWY, BROOMFIELD, CO 80021

ISSUE/REVISION	DATE	NO.
100% CDS	05/09/22	
ASI #1	06/13/22	①
ASI #2	03/26/24	②

BOILER PLAN - ELECTRICAL

DRAWN BY	JMB
DESIGN BY	JMB
CHK'D BY	KAM

THIS DOCUMENT, INCLUDING ALL IDEAS AND DESIGNS, IS THE PROPERTY OF 20/20 ENGINEERING, INC. WHO HAS PROVIDED A PROFESSIONAL DESIGN SERVICE AND CANNOT BE USED OR REPRODUCED IN WHOLE OR IN PART BY ANY OTHER PARTY FOR PERMIT, BIDDING OR INSTALLATION PURPOSES FOR THIS OR ANY OTHER PROJECT WITHOUT THE WRITTEN AUTHORIZATION OF 20/20 ENGINEERING, INC. COPYRIGHT 2024.

EXHIBIT B
PROJECT NARRATIVE

[See attached.](#)

CITY OF BROOMFIELD DETENTION CENTER HW- DHW PLANT REPLACEMENT

Broomfield, Colorado

March 20, 2024
Revision 1

MECHANICAL/PLUMBING NARRATIVE:

Demolition:

- Demolish Existing Equipment
 - Two (2) 1.8 MMBtu natural gas HW boiler and comb air and exhaust flues.
 - One (1) 2.3 MMBtu natural gas HW boiler and comb air and exhaust flues.
 - Two (2) 1.0 MMBtu natural gas DHW heaters and comb air and exhaust flues.
 - Two (2) 400 MBtu natural gas DHW storage tank heaters.
 - Two (2) 752 gallon DHW storage tanks.
 - Combustion air fan.
 - Four (4) HW primary and secondary pumps and motor drives.
 - HW air separator.
 - Two (2) HW expansion tanks.
 - Two (2) DHW expansion tanks.
 - High/Low Thermostatic Mixing Valve.
- Demolish Equipment Ancillaries and Utilities
 - Piping back to main tee or fitting or iso valve.
 - Power wiring back to panel.
 - Control wiring back to panel.
- Demolish Building Wall/Floor/Roof Req Openings
 - Old vent terminations through roof.
 - Equipment housekeeping pads.
 - New vent path assembly penetrations.

Relocate:

- Relocate Existing Equipment
 - Electronic Mixing Valve.
 - DHW recirculation Pump.
 - DHW (140) deg F recirculation Pump.

New Work:

- Phasing
 - Contractor shall plan to install, start-up and temporarily commission new DHW boilers and re-feed existing storage tanks and all TMV and EMV mixing stations during majority demo work in order to minimize down time of DHW supply to the occupied facility.
- New Equipment (provide all major equipment and accessories as scheduled)
 - Two (2), 1.0 MMBH natural gas HW mod. con. boilers. Combined combustion air to existing louver. PP vent roof.



- Eight (8) 200 MBH instantaneous natural gas DHW con. boilers (Two (2) sets of Four (4) pre-piped racks). Combined combustion air to existing louver. Combined PP vent roof.
- Two (2) HW CV primary pumps and Two (2) variable speed secondary pumps.
- Two (2) DHW CV circulating pumps.
- Two (2) 500 gallon DHW storage tanks, cement lined.
- Magnetic HW air separator.
- HW expansion tank.
- DHW expansion tank.
- Electronic mixing valve.
- Two (2) condensate neutralizers.
- Equipment Ancillaries and Utilities
 - Piping utilities and specialties as detailed.
 - Reuse existing glycol feeder, pot-feeder, and DHW recirc pump.
 - Power wiring/conduit back to panel.
 - Control wiring for complete functional system per sequence of operation. Basis of Design:
 - Stand-alone boiler factory controls interlocked with all HW pump control and existing BAS BACnet/IP tie-in for scheduling, OAT, and HW plant point monitoring/trending.
 - Stand-alone pump sequencer and controls interlocked with all DHW circulating pumps.
 - Stand-alone electronic mixing valve controls with existing BAS BACnet/IP tie-in for scheduling, HW temp monitoring/trending.
- Weather Tight and Repaired Building Wall/Floor/Roof Req Openings
 - Equipment housekeeping pads.
 - New vent path assembly penetration repair.
- Additional Prime Contractor Responsibilities
 - Building HW drain, flush, new pipe clean and passivation, and final fill/air purge with demineralized fluid in compliance with boiler manufacture hardness/pH requirements.
 - Electrical power in compliance with current NEC.
 - Roof penetration repair via contractor holding Owner's roof warranty.
 - New interior gas pipe painted safety yellow.
 - New pipe system and flow direction labels.
 - Submittals for EOR approval for all scheduled equipment, specialty fittings, materials, vent assembly, control wiring diagram, control parts list, control sequence of operation.
 - Equipment start-up and start-up reports, test and balance reports, domestic sterilization documentation, and final HW fluid chemistry lab reports for EOR and Owner review.
 - On-site, 3 hr Owner training.



Exhibit C
Contractor's Cost Proposal

[See attached.](#)

PROPOSAL – P04598 R2

Date: 8-1-24



Customer: City and County of Broomfield

Rev. Date: 8-1-24: removed electrical scope

Attention: Samuel Lewis

Job Name: Detention Center- HW-DHW
Plant Renovation

Customer Address: One DesCombes Drive
Broomfield, CO 80020

Job Address: 11600 Ridge Pkwy
Broomfield, CO 80021

Phone:

Fax:

INTRODUCTION:

Design Mechanical, Inc., the premier provider of HVAC building solutions and energy services, is pleased to provide you with the following Proposal.

The undersigned customer (“Customer”) authorizes Design Mechanical, Inc. (“Company”) to furnish labor, material, and related services as described below.

DESCRIPTION:

Perform mechanical work for the City and County of Broomfield Detention Center for the HW-DHW Plant Renovation per drawings dated 5-9-22 with latest ASI#2 dated 3-26-24.

Includes:

- (2) Aerco Boilers
- (4) Heating water pumps
- Expansion tank and air separator
- Copper heating water piping for 2” and smaller
- Heating water pipe 2 ½” and larger to be black steel with welded or grooved fittings
- Glycol
- Permit fees will be waived by the City and County -assumed
- Housekeeping pad modifications if necessary
- Polypropylene flue for heating boilers
- Galvanized combustion air for boilers
- Engineered venting for Rinnai water heaters
- Necessary pipe insulation
- CO2 detectors
- Controls by owner
- Electrical by owner
- Water balance
- Roofing
- Necessary domestic water piping
- (2) domestic water heat racks with (4) heaters per rack
- (2) domestic hot water pumps
- Relocation of (2) recirculation pumps
- Condensate piping run in M copper
- (1) thermostatic mixing valve
- Demolition
- Regular and some afterhours labor for cut overs

- Start up and check out

EXCLUSIONS:

Anything not listed above.

- Asbestos abatement
- Permit fees- assumes they are covered by the city and county
- Controls- by owner
- Electrical, mechanical, or structural engineering or drafting (e.g. as-builts, etc.)
- Fire protection system work
- Line voltage electrical and new disconnects
- Overtime or after hours work
- Structural modifications to accommodate installation of equipment
- Building utility upgrades
- Test and balance of air distribution system

PRICING:

TOTAL, NOT INCLUDING TAXES: \$ 453,233.00

Hydronic Boiler System Equipment	\$ 102,228.00
Domestic Boiler System Equipment	\$ 75,275.00
Installation and materials hydronic	\$ 115,905.00
Installation Hot Water	\$ 142,163.00
Electrical - by owner	\$ -
Controls By owner sub	\$ -
Hydronic demo	\$ 9,078.00
Domestic Demo	\$ 8,584.00
	\$ 453,233.00

Performance and Payment bond Cost: \$ 1,812.00

Price good for 30 days from date of this Proposal.

TERMS AND CONDITIONS:

The parties' contract consists of this Proposal (after it has been fully signed) and the attached Terms and Conditions.

PROPOSAL PROVIDED BY:

Name: Mike Van Allen Cell 303-210-9750
 Title: Service Sales Email: mike.vanallen@comfortsystemsusa.com

ACCEPTANCE OF PROPOSAL:

The terms of this Proposal are accepted by Customer. This Proposal becomes a Contract only if it is also signed below by an officer of Company. Company is authorized to do the work specified and payments will be made as outlined above.

Agreed to and accepted this _____ day of _____, 2024.

Customer: _____ Design Mechanical, Inc.

By: _____ By: _____

Title: _____ Title: _____

Signature: _____ Signature: _____

Date: _____ Date: _____

This Proposal was prepared exclusively for the review and evaluation by Customer. The material supplied within this document contains proprietary information pertaining to Company and our development of the solution for your facility, and this Proposal remains the property of the Company.

This Proposal and any enclosures are not to be copied or disclosed to other individuals, vendors, or companies. Should you elect for whatever reason not to accept Company’s Proposal, Company’s sales representative will pick up this Proposal at a mutually convenient time.

We appreciate this opportunity to consult you in these matters and thank you for your understanding regarding the proprietary nature of this Proposal.

TERMS AND CONDITIONS

1. **PAYMENT.** Design Mechanical, Inc. ("Company") reserves the right to invoice Customer as the work progresses, including for all materials delivered to the jobsite or to an off-site facility and for all work performed on-site and off-site. Engineering, drafting, and other mobilization costs shall be included in Company's initial invoice and be equal to fifteen percent (15%) of the total Contract price. Payment is to be received by Company within fifteen days of the invoice. If Customer fails to pay timely, Company shall be entitled to terminate this Contract, shall be entitled to interest at eighteen percent (18%) per annum, and shall also be entitled to avail itself of all other remedies. If Customer cancels this Contract, Customer shall pay Company for all costs Company has incurred and all profit that Company would have earned on the Contract but for the cancellation.

2. **TITLE.** Customer acknowledges that title to all goods provided by the Company is held in the name of the Company, and that title shall transfer to the Customer after it has complied with all of its obligations. Customer's failure to pay any amounts when due will give Company the right to possession and removal of all goods and material at any time. The taking of such possession by Company will be without prejudice to any other remedies Company may have. All goods shall be F.O.B. the Company's place of business.

3. **WARRANTY.** Company warrants that the equipment provided and services furnished by it are free from defects in material and workmanship under normal use and service for one year. MAKES NO OTHER WARRANTIES OF ANY KIND, EITHER EXPRESS OR IMPLIED, WITH RESPECT TO THE PRODUCTS AND COMPANY EXPRESSLY DISCLAIMS ANY IMPLIED WARRANTIES OF MERCHANTABILITY AND FITNESS FOR A PARTICULAR PURPOSE OR USE.

4. **CUSTOMER'S REMEDIES.** Any defects in equipment and workmanship will be repaired or replaced, at the Company's option, if written notice of the defect is received by the Company within ninety (90) days following installation, provided the equipment has been operated in accordance with all instructions and the defect is not due to abuse or misuse. All returns are subject to Company's review and, if accepted, (a) non-warranty returns will be subject to Company's restocking and refurbishing charges and (b) non-warranty repairs will be subject to Company's then-current charges. Customer shall have no remedy for damages incurred as a result of an Act of God, vandalism, act of terrorism, or any other acts outside the control of Company. In no event shall Company's liability be greater than the lower of the annual or total price of this Contract. THE COMPANY WILL NOT IN ANY EVENT BE LIABLE FOR INCIDENTAL, CONSEQUENTIAL, OR SPECIAL DAMAGES OF ANY KIND, INCLUDING LIABILITY FOR LOSS OF USE, LOSS OF WORK IN PROGRESS, DELAY DAMAGES, LOSS OF REVENUE OR PROFITS, OR ANY LIABILITY OF CUSTOMER TO A THIRD PARTY, INCLUDING LIABILITY FOR BODILY INJURY OR PROPERTY DAMAGE.

5. **COMPANY'S REMEDIES.** If Customer fails to make a payment in accordance with the terms of this Contract, Company, in addition to its other remedies, may defer further work for Customer and may terminate this Contract, and Customer will have no cause of action and will not be entitled to any setoff, counterclaim, or recoupment against Company. Customer agrees that Company may at any time obtain credit and financial information regarding Customer. Refusal by Customer to provide any information requested by Company permits Company to terminate this Contract. Customer agrees to pay all costs, including attorney fees and costs of dispute resolution, which may be incurred by the Company in its enforcement of this Contract.

6. **PRICING.** All work covered by this Contract shall be performed between 8:00 a.m. and 4:30 p.m., Monday through Friday, except holidays. If it is necessary that work be performed at other times, Customer agrees to pay the difference between Company's regular and overtime charges.

7. **TAXES AND OTHER CHARGES.** Customer shall be responsible for all taxes, surcharges, duties, and related costs imposed by any authority, unless Company has expressly assumed responsibility for such taxes and other charges.

8. **DISPUTE RESOLUTION.** If Customer believes that Company has not complied with any of its obligations arising under, related to, or incidental to this Contract, Customer shall give Company written notification of the claimed breach. Upon receipt of the notification, Company shall within twenty days review the dispute and give Customer a written decision regarding the dispute. Company's decision shall be binding upon the parties unless Customer gives written notice within twenty days of its intent to proceed further with dispute resolution. If Customer gives notice of intent to proceed or if Company believes that Customer has not complied with its obligations arising under, related to, or incidental to this Contract, Company shall within twenty days designate the forum for dispute resolution from one of the following: (1) binding arbitration before a single arbitrator with the Judicial Arbitrator Group or any other comparable, private dispute resolution association selected by Company or (2) trial to the District Court, Boulder County, Colorado (the Customer having agreed to waive any right it might have to a jury trial). The Company's designation of the forum for dispute resolution is binding on the parties.

9. **ADDITIONAL PROVISIONS.**

(a) The Company will not be responsible for any delay or failure to perform or deliver resulting from any act of God, labor dispute, fire, flood, strike, work stoppage, accident, casualty, international or domestic conflict, difficulty in obtaining materials or labor, energy shortage, delay in shipment by the Company's suppliers, or any other cause beyond the Company's reasonable control.

(b) Time is of the essence.

(c) This Contract will be governed and construed by and enforced under the internal laws of the State of Colorado.

(d) Customer agrees that it will not hire as its employee any Company employee or Company subcontractor during the term of this Proposal and for twelve (12) months following termination of this Proposal.

(e) If any provision of this Contract, or the application thereof, becomes or is declared by a court of competent jurisdiction to be illegal, void, or unenforceable, the remainder of this Contract will continue in full force and effect and the application of such provision to other persons or circumstances will be interpreted so as reasonably to effect the intent of the parties hereto.

(f) Customer agrees to indemnify and hold harmless Company from all suits, claims, and damages of any kind, including attorney fees, arising out of, in connection with, or incidental to this Contract.

(g) This Contract is intended by the parties to be the final expression and the complete and exclusive statement of all terms of their agreement. Captions appear in this Contract only for convenient reference and they do not affect the meaning. This Contract can not be modified or amended except in a writing signed by the parties.

(h) The failure to require strict compliance or performance of any one or more terms of this Contract on one or more occasions will not be deemed a waiver of that or any other term on that or any other occasion. Any waiver of a right or remedy under this Contract must be contained in a writing signed by the waiving party.

Exhibit D
INSURANCE REQUIREMENTS

[See Attached](#)

CITY and COUNTY of BROOMFIELD INSURANCE REQUIREMENTS - Including Professional Liability

1. All insurers must be licensed or approved to do business within the State of Colorado.
2. Contractor/Vendor's insurance carriers should have an A.M. Best Company rating of at least A- VII.
3. Additional Insured - City and County of Broomfield, its officers, board members, agents, employees and volunteers acting within the scope of their duties for the City and County of Broomfield shall be named as Additional Insured on all Commercial General Liability, and Automobile Liability Insurance policies (construction contracts require Additional Insured coverage for completed operations).
4. Primacy of Coverage – Coverage required of Contractors and Subcontractors shall be primary and non-contributory to any insurance carried by the City and County of Broomfield
5. All subcontractors must meet the same insurance requirements for the Contract or Purchase Order unless Risk Management has approved a deviation.
6. Subrogation Waiver – All insurance policies required under this Contract maintained by Contractor or its Subcontractors shall waive all rights of recovery against City and County of Broomfield, its officers, board members, agents, employees and volunteers acting within the scope of their duties for the City and County of Broomfield.
7. Cancellation, Change in Coverage or Limits – The above insurance policies shall include provisions preventing cancellation, non-renewal, or reduction in coverage or limits of any insurance, without at least 30 days prior notice to Contractor/Vendor and Contractor/ Vendor shall forward such notice to within seven days of receipt of such notice.
8. Certificates – Contractor and all Subcontractors shall provide certificates showing insurance coverage required hereunder to the City and County of Broomfield within 5 days of:
 - a. the effective date of the Contract
 - b. the expiration date of any coverage
 - c. a request by the City and County of Broomfield
9. Separation of Insureds. All insurance policies shall include coverage for cross liability and contain a "Separation of Insureds" provision in the general liability policy.
10. City and County of Broomfield in no way warrants that the limits required herein are sufficient to protect the Contractor/Vendor from liabilities that may arise out of the performance of the work under this Contract by the Contractor, its agents, representative, employees or subcontractors. The Contractor is not relieved of any liability or other obligations assumed or pursuant to the Contract by reason of its failure to obtain or maintain insurance in sufficient amounts, duration or type.
11. All parties understand and agree that the City and County of Broomfield is relying on, and does not waive or intend to waive by any provision of this Contract, the monetary limitations, immunities, protections or any other rights provided by the Colorado Governmental Immunity Act.
12. The City and County of Broomfield reserves the right to negotiate additional specific insurance requirements at the time of the Contract.
13. The City and County of Broomfield and Contractor shall cooperate with each other in the collection of any insurance proceeds which may be payable in the event of any loss, including the execution and delivery of any proof of loss or other actions required to effect recovery.

Vendor/Contractor/Subcontractor shall obtain and maintain, at its own expense and for the duration of the contract including any warranty periods under which the Contract are satisfied, the following:

Insurance Requirements - Including Professional Liability		
	COVERAGES AND LIMITS OF INSURANCE	Required
1.	<p>Commercial General Liability Commercial General Liability insurance covering all operations by or on behalf of the contractor/vendor on an occurrence basis against claims for bodily injury, property damage (including loss of use), advertising liability, products and completed operations, and contractual liability.</p> <p>Note: For contracts involving vendor/contractor contact with minors or at-risk adults, Sexual Abuse and Misconduct Coverage should be included in the coverage requirements.</p>	<ul style="list-style-type: none"> • \$1,000,000 Each occurrence • \$2,000,000 General Aggregate (Per Project) • \$2,000,000 Products/Completed Operations Aggregate (for construction projects, this coverage should be maintained for a minimum of 3 years from the end of the project)
2.	<p>Automobile Liability Automobile Liability Insurance covering any auto (including owned, hired and non-owned autos).</p>	<ul style="list-style-type: none"> • \$1,000,000 combined single limit • If hazardous materials are transported, an MCS 90 form shall be included on the policy
3.	<p>Workers' Compensation Workers' Compensation Insurance as required by State statute, covering all Vendors/Contractors employees acting within the course and scope of their employment.</p> <p>This requirement shall not apply if exempt under Colorado Workers' Compensation Act, AND when providing the sole proprietor waiver form.</p>	<p>Employer's Liability with Minimum Limits:</p> <ul style="list-style-type: none"> • \$100,000 Each Accident • \$100,000 Each Employee by Disease • \$500,000 Disease Aggregate
4.	<p>Professional Liability Contractor will purchase and maintain professional liability insurance covering any damages caused by an error, omission or negligent professional act to include the following: Coverages:</p> <ul style="list-style-type: none"> • If coverage is Claims Made, a retroactive date prior to the inception of the work • If coverage is Claims Made, similar coverage must be maintained for three years following the completion of the work or an extended reporting period of 36 months must be purchased 	<p>Minimum Limit:</p> <ul style="list-style-type: none"> • \$1,000,000 Per Claim • \$2,000,000 General Aggregate
<p>Additional Insured - The following shall be named an Additional Insured: The City and County of Broomfield, its officers, board members, agents, employees and volunteers acting within the scope of their duties for the City and County of Broomfield shall be named as Additional Insured on all Commercial General Liability, Umbrella Liability and Automobile Liability Insurance policies (construction contracts require Additional Insured coverage for completed operations). A Waiver of Subrogation is provided in favor of the Additional Insureds as respects to all policies.</p> <p>Certificate Holder is: City and County of Broomfield One DesCombes Drive Broomfield, CO 80020-2495 certificates@broomfield.org</p>		

Any deviations below the standards given above must be approved by the City and County of Broomfield's Risk Management office. Please direct any questions to RiskManagement@broomfield.org



Proposed Resolutions for Aggregate Spend Increase for Water Technology and Browns Hill

Meeting	Agenda Group
Tuesday, September 10, 2024, 6:00 PM	Consent Items Item: 6F
Presented By	
Ken Rutt, Director of Public Works	
Community Goals	
<input checked="" type="checkbox"/> Financial Sustainability and Resilience	

Overview

[View Correspondence](#)

Broomfield Municipal Code, [Section 3-20-040\(B\)](#), requires Council approval when the aggregate of multiple purchase agreements in any calendar year with a single vendor for the same or similar supplies or services exceeds \$200,000.

To date in 2024, Water Technology Group has been used to purchase industrial equipment, supplies, and provide services on industrial equipment at the Water Treatment Facility, Water Recovery Facility, various booster and lift stations throughout Broomfield, and equipment purchases for the Facilities Division. Resolution No. 2024-115 authorizes and approves an increase in the aggregate spend with Water Technology Group not to exceed \$465,000 in 2024.

To date in 2024, Browns Hill Engineering and Controls, LLC has been used to purchase instrument and controls equipment, controls programming assistance and other engineering services for the Water Treatment Facility, Water Recovery Facility, and various booster and lift stations throughout Broomfield. Resolution No. 2024-116 authorizes and approves an increase in the aggregate spend with Browns Hill Engineering and Controls, LLC in an amount not to exceed \$275,000 in 2024.

Attachments

[Memo Request for Aggregate Spend Increase for Water Technology Group and Browns Hill.pdf](#)

[Resolution No. 2024-115.pdf](#)

[Resolution No. 2024-116.pdf](#)

Summary

[View Correspondence](#)

Public Works' Utilities, Instrumentation & Controls, Water Treatment, and Water Recovery/Wastewater Divisions are responsible for maintaining and operating Broomfield water infrastructure facilities. Various departments and divisions require industrial equipment and supplies for projects, facilities and stations throughout the year, or when there is an emergency replacement of equipment. The divisions work to standardize equipment, as much as possible, for compatibility, maintenance, and uniformity throughout City facilities.

Broomfield Municipal Code, [Section 3-20-040\(B\)](#) requires Council approval when the aggregate of multiple purchase agreements in any calendar year, with a single vendor for the same or similar supplies or services, exceeds \$200,000. This memo provides justification for aggregate spending requests above \$200,000 for two vendors that are integral to Broomfield's water infrastructure needs - Water Technology Group and Browns Hill Engineering and Controls, LLC. The proposed costs include planned maintenance and repairs as well as emergency repairs to date and budget for potential emergency repairs in the remainder of 2024. The aggregate spending limits requested fall within the planned 2024 budget.

In May 2021 the City and County of Broomfield pre-qualified 5 vendors through a competitive Invitation For Bid to provide scheduled pump maintenance and emergency maintenance and repairs as needed at City owned and operated water utility facilities. Specified pump maintenance includes pulling, inspecting and repairing vertical turbine high service pumps and vertical turbine backwash pumps. The pre-qualification process allows the City to contract these vendors directly as needed without undergoing additional solicitation processes - an important administrative strategy to ensure timely response when repairs are needed on an urgent or emergency basis or when maintenance requires working with a short list of manufacturer-approved distributors.

Water Technology Group, one of the five pre-qualified vendors, is the municipal distributor for leading manufacturers of much of Broomfield's water and wastewater pump and process equipment. Maintenance and repair of this equipment usually requires support and/or equipment from Water Technology Group. To date in 2024, Water Technology Group has been used to purchase industrial equipment, supplies and provide services on industrial equipment at the Water Treatment Facility, Water Recovery Facility, water booster and lift stations throughout Broomfield, and equipment purchases for the Facilities Division.

The proposed expenditures with Water Technology Group for 2024 are expected to be \$425,000.

Browns Hill Engineering and Controls, LLC (Browns Hill) is an electrical engineering consulting firm and controls system integrator specializing in the integration and controls equipment for water and wastewater systems as well as support services to their municipal clients.

In 2018, Browns Hill was awarded, through the RFP #17-043 public bidding process, the contract to modernize the Supervisory Control and Data Acquisition (SCADA) system for the City and County of Broomfield. The SCADA system remotely controls and monitors the 26 million gallon-per-day (MGD) water treatment facility for potable water, the 12 MGD treatment facility for wastewater and reclaimed water, the 6 MGD facility for the non-potable water system, and numerous pumps and other components key to the systems operation. This project was completed in 2021.

To date in 2024, Browns Hill Engineering and Controls, LLC has been used to purchase instrument and controls equipment, controls programming assistance and other engineering services for the Water Treatment Facility, Water Recovery Facility, and various booster and lift stations throughout Broomfield.

Staff from Public Works and IT continually evaluate and perform routine SCADA hardware and software updates. It is critical to the overall operations to optimize the SCADA system performance and efficiency, by identifying and resolving issues, upgrading software and hardware, tuning and calibrating parameters and settings. The industry standard for SCADA server replacement is every 5 years due to technology advancements and reliability. One of the tasks assigned to Brown Hill is to re-evaluate the SCADA system and identify enhancements to ensure the system's resilience going forward. This will ensure the availability and functionality of the SCADA system, which is critical for the operation and safety of the processes and equipment it control as well as enhance security functions from the rising threats of cyber attacks. The proposed expenditures with Browns Hill for 2024 are expected not to exceed \$275,000.

Resolution No. 2024-115 authorizes and approves an increase in the aggregate spend with Water Technology Group not to exceed \$465,000 in 2024.

Resolution No. 2024-116 authorizes and approves an increase in the aggregate spend with Browns Hill Engineering and Controls, LLC in an amount not to exceed \$275,000 in 2024.

Financial Considerations

As shown in the sources and uses of funds summary below, the project can be completed within the budgeted amount.

Water Technology Group

Sources and Uses of Funds	Amount
Fund 1 40-70111-55600	\$197,710
Fund 2 47-39100-52790	\$4,150
Fund 3 40-35300-52790, XUT0005	\$33,720
Fund 4 20-70011-55600-OAZ0075	\$22,000
Fund 5 52790 XWW0030, 45-37100-52190 XWW0030	\$182,600
Fund 6 40-70531-55600, OAZ0451	\$50,000
Fund 7 45-70621st-55200, OAZ0450	\$100,000
Total Funds Budgeted	\$590,180
Project Expenses	
Water Treatment: High Service Pump #6	-\$55,164
Water Treatment: High Service Pump #3	-\$57,250

Sources and Uses of Funds	Amount
Water Treatment: Repair and Maintenance of Backwash Waste Pump #1	-\$25,847
Facilities: Repairs to HVAC and HVAC pumps at HHS and Detention and Pool Pump Replacement	-\$11,999
Facilities: Future 2024 HVAC Repairs As Needed	-\$10,000
Water Recovery: Pump Repairs, Repair parts	-\$56,791
Water Recovery: Quotes for parts, i.e. stators, rotors, mechanical seals, drive shaft couplings and pump volutes, for repair to existing pumps	-\$127,600
Utilities: Repair and Maintenance of pumps Airport Boost 75hp	-\$3,878
Utilities: Raw Water Pump Station Turbine Repair	-\$59,449
Utilities: Raw Water Pump Station rebuild pump #1	-\$9,853
Total Expenses	\$417,831
Projected Balance	\$172,349

Browns Hill Engineering and Controls

Sources and Uses of Funds	Amount
Fund 1 47-39200-53630	\$1,000
Fund 2 47-39200-53690	\$8,400
Fund 3 45-37100-53630	\$36,200
Fund 4 45-37100-53690	\$69,600
Fund 5 40-35200-53690	\$45,000
Fund 6 40-36100-52790	\$40,000
Fund 7 40-36100-53630	\$10,000
Fund 8 40-36100-53690	\$2,000
Fund 9 45-36100-52790	\$50,000
Fund 10 45-36100-53630	\$28,000
Fund 11 45-36100-53690	\$10,000
Fund 12 45-37300-52790, XUT0035	\$1,033

Sources and Uses of Funds	Amount
Total Funds Budgeted	300,200
Project Expenses	
Current Services Invoiced/Paid	-\$35,515
Airport Booster Pump Station Emergency Repair	-\$33,604
Northland Lift Station Pump Variable Frequency Drive	-\$46,485
Anthem Lift Station Pump 2 replacement of damaged electrical gear	-\$9,801
SCADA (Supervisory Control and Data Acquisition) Assessment & Development to re-architecture SCADA system hardware, software, and communication requirements for additional cybersecurity resilience.	-\$75,000
Anticipated Emergency Services Expected to the end of 2024	-\$74,000
Total Expenses	-\$274,405
Projected Balance	\$25,828

Prior Council or Other Entity Actions

None

Boards and Commissions Prior Actions and Recommendations

N/A

Proposed Actions / Recommendations

If Council desires to approve the resolutions, the appropriate motion is...
That Resolution 2024-115 (Water Technology Group) be approved.
That Resolution 2024-116 (Browns Hill Engineering) be approved.

Alternatives

Council could choose not to approve the resolutions, postponing maintenance and repair work until 2025.

RESOLUTION NO. 2024-115

A resolution authorizing and approving an increase in the aggregate spend with Water Technology Group

Be it resolved by the City Council of the City and County of Broomfield, Colorado:

Section 1.

The City and County Manager or a designee thereof is authorized to approve agreements and purchase orders from Water Technology Group, with aggregate total payments not to exceed \$465,000 for 2024 expenditures.

Section 2.

This resolution is effective upon its approval by the City Council.

Approved on September 10, 2024.

The City and County of Broomfield, Colorado

Mayor

Attest:

Office of the City and County Clerk

Approved as to form:

NCR

City and County Attorney

RESOLUTION NO. 2024-116

A resolution authorizing and approving an increase in the aggregate spend with Browns Hill Engineering and Controls, LLC

Be it resolved by the City Council of the City and County of Broomfield, Colorado:

Section 1.

The City and County Manager or a designee thereof is authorized to approve agreements and purchase orders from Browns Hill Engineering and Controls, LLC, with aggregate total payments not to exceed \$250,000 for 2024 expenditures.

Section 2.

This resolution is effective upon its approval by the City Council.

Approved on September 10, 2024.

The City and County of Broomfield, Colorado

Mayor

Attest:

Office of the City and County Clerk

Approved as to form:

NCR

City and County Attorney

Summary

[View Correspondence](#) and Broomfieldvoice.com

Introduction

The owner of the property at 1257 Clubhouse Drive has submitted an application for a revocable permit in order to install private landscaping in a portion of the city-owned Outlot A of Broomfield Country Club Filing No. 4. The applicant has submitted a [letter regarding this request](#). The property at 1257 Clubhouse Drive is located adjacent to both Outlot A, and the Eagle Trace Golf Course. This is part of a larger project the applicant is currently undertaking to improve the accessibility of the property. The revocable permit would allow installation of a gate and path from the rear of the residence to the street so that the applicant's son, who is confined to a wheelchair, would have an alternative exit to use in a power outage.

Tract A is owned by the City and County of Broomfield. The tract includes an existing concrete walk and a fence. The fence was installed many years ago and is not located on the property line, but rather is located approximately 9 feet west of the property line shared with the applicant. Historically the property owners at 1257 Clubhouse Drive have maintained the turf area between their property and the existing fence and continue to do so. The issue regarding ownership of the portion of Tract A located east of the fence arose when the property owners requested to place a gate in the existing fence to connect to the proposed emergency ADA access route.

The applicant's property location is outlined in orange and the revocable permit project boundary is shown in blue in the aerial photograph. The southwest corner of the applicant's home abuts the property line.

A revocable permit is required since the applicant is proposing private improvements on public property. A detailed plan for the improvements are available [in this document](#). The improvements shown on Tract A include a crusher fines path running parallel to the fence as well as a portion of a turnaround area where the trail turns to connect to the driveway. This crusher fines path connects a ramp to the raised deck of the home and the driveway accessing Clubhouse Drive. The applicant is also proposing to install a gate in the fence to allow for private ADA access between the existing pedestrian pathway and the rear yard of the home.



Other than the addition of a gate, there are no changes proposed to the existing fence within Tract A.

Revocable Permit - 1257 Clubhouse Drive
Prepared by: Ted Harberg

Finally, the applicant is proposing to replace non-functional turf with buffalo grass for the area within Tract A east of the fence since this area will need to be restored after construction of the crusher fines path. The buffalo grass is drought tolerant and has low watering requirements. Irrigation for this area will be provided by the applicant.

The revocable permit agreement outlines responsibility for the improvements, including that the applicant is solely responsible for the cost of the improvements, the applicant is responsible for maintaining the improvements, and Broomfield has the right to require the improvements to be removed upon notice. If the improvements are removed, the applicant is responsible for restoring the property to its original condition.

In addition to a revocable permit, Broomfield (CCOB) will require a Public Private Improvement Permit to approve the landscaping changes on Broomfield property, and an Access Permit to approve a new private gate used to access the Broomfield sidewalk.

The owner of 1257 Clubhouse Drive also has an existing easement to install landscaping on a defined area of the Eagle Trace Golf Course, located to the south of the rear yard. This area is not a part of the requested revocable permit.

Financial Considerations

The applicant will be required to pay permit fees and any associated maintenance costs. In the event Broomfield needs to revoke the permit in the future, the permit agreement requires the applicant to remove their improvements and restore the property to its original condition at their expense.

Prior Council or Other Entity Actions

N/A

Proposed Actions/Recommendations

If Council desires to proceed with the permit, the appropriate motion is...

That Resolution No. 2023-121 be adopted.

Alternatives

Do not approve the revocable permit.

RESOLUTION NO. 2024-121

A resolution approving a Revocable Permit with Andreea I. Arvinte and Cristian Arvinte for Private Landscaping and Improvements on Outlot A of Broomfield Country Club Filing No. 4

Be it resolved by the City Council of the City and County of Broomfield, Colorado:

Section 1.

Andreea I. Arvinte and Cristian Arvinte, the owners of the adjacent property located at 1257 Clubhouse Drive, have submitted an application for a revocable permit on Outlot A of Broomfield Country Club Filing No. 4 to allow the installation of private landscaping, a gravel path and a gate for private ADA access.

Section 2.

Pursuant to the provisions of Section 17.9 of the Broomfield Charter, the Revocable Permit by and between the City and County of Broomfield and Andreea I. Arvinte and Cristian Arvinte for private landscaping and improvements on Outlot A of Broomfield Country Club Filing No. 4 is hereby approved.

Section 3.

This resolution is effective upon its approval by the City Council.

Approved on September 10, 2024.

The City and County of Broomfield,
Colorado

Mayor

Attest:

Office of the City and County Clerk

Approved as to form::

KKH

City and County Attorney

AN AGREEMENT BY AND BETWEEN THE CITY AND COUNTY OF BROOMFIELD
AND THE ARVINTES FOR THE GRANT OF A REVOCABLE PERMIT TO USE AND
OCCUPY CITY OWNED PROPERTY
LOCATED AT OUTLOT A OF THE BROOMFIELD COUNTRY CLUB FILING NO. 4
SUBDIVISION

- 1.0 PARTIES. The parties to this Agreement for the Grant of a Revocable Permit (this "Agreement") are the City and County of Broomfield, a Colorado municipal corporation and body politic and corporate of the State of Colorado (the "City"), and Andreea I. Arvinte and Cristian Arvinte, as joint tenants (the "Permittee"), collectively, the "Parties," or individually, a "Party."
- 2.0 RECITALS AND PURPOSE.
- 2.1. The City owns that certain property legally described as Outlot A of Broomfield Country Club Fourth Filing, City and County of Broomfield, State of Colorado (the "Property").
- 2.2. The Permittee, the owner of the property located at 1257 Clubhouse Drive also known as Lot 41 of Broomfield Country Club Fourth Filing, desires to access the City property for the purpose of installing private landscaping including shrubs, a gravel path, and a gate for private ADA emergency access only in the existing fence as indicated on **Exhibit A**, attached hereto and incorporated herein (the "Facilities").
- 2.3. The City desires to grant a revocable permit to the Permittee under the terms and conditions as provided in this Agreement.
- 3.0 TERMS AND CONDITIONS. For and in consideration of the mutual covenants and promises contained herein, the sufficiency of which is acknowledged, the Parties agree as follows:
- 3.1. Grant of Permit. The City hereby grants to the Permittee a revocable permit for right to construct, maintain, operate, repair, inspect, remove and replace the Facilities, as depicted on **Exhibit A** within the Property as described herein until such permit is terminated as provided herein (the "Revocable Permit"). The Permittee acknowledges and agrees that the City currently uses and intends to continue to the use the Property for utility and pedestrian purposes, and the rights granted to the Licensee for use of the Property are subject to the rights of the City to use the Property for utilities and pedestrian access or other purposes as permitted by law which the County expressly reserves.
- 3.2. Construction and Alterations. The Permittee agrees to construct any structures or improvements placed in the Property at the expense of the

Permittee. The Permittee shall not begin any construction or alteration of the Property until the Permittee first provides the City with plans and specifications, and such plans and specifications have been approved by the City. In addition, the Permittee shall obtain any other permits required for the construction, including but not limited to a Public/Private Improvement Permit, as applicable. If the Permittee's construction requires any deviation in any manner from the approved plans and specifications, the Permittee shall notify and obtain prior written approval from the City for any changes in advance of any construction or alteration. Any damage to existing facilities located on the Property as a result of the Permittee's construction or alteration of the Facilities shall be paid for by or repaired at the expense of the Permittee. These provisions shall also apply to any other work involving the maintenance, operation, repair, inspection, removal, replacement, or relocation of the Facilities on the Property. After initial construction of the Facilities and thereafter, in the event of resettling, the Permittee shall restore the surface of the Property by grading and compacting any irregularities, reseeding, and/or revegetation as required to restore original conditions, as applicable.

- 3.3. Maintenance and Repair. The Permittee agrees to maintain, and repair any structures or improvements placed in the Property at the expense of the Permittee and in accordance with Section 3.2 above. The Permittee agrees that the City is not and will not assume any liability, responsibility, or costs for any damage or maintenance to any Facilities erected by the Permittee on the Property under this Agreement.
- 3.4. Prior Rights. This Revocable Permit is issued subject to any prior permits, easements, leases or other rights granted by the City, or its predecessors, for improvements of other parties. The City reserves the right to permit others to install improvements in, on, under, or along the Property. The Permittee acknowledges that utilities may be located in and under the Property. The Permittee is advised to contact the Utility Notification Center of Colorado (1-800-922-1987) at least two (2) working days prior to the commencement of construction on the Property to arrange for field locating of utility facilities which may affect the Property.
- 3.5. Termination. The use and occupancy described in the Revocable Permit shall continue from the date of this Agreement to the time that this Agreement is terminated. The City may terminate this Agreement at any time by giving written notice to the Permittee ten days in advance of the effective date of termination and specifying the date of termination therein. Upon termination of this Agreement by the City pursuant to this section, Permittee shall, at its expense, remove the Facilities from the Property and restore the general surface of the Property, as nearly as may reasonably be, to the grade and conditions it was immediately prior to the

placement of the Facilities on the Property. The Permittee shall obtain any permits required for the removal of the Facilities, including but not limited to a Public/Private Improvement Permit, as applicable.

- 3.6. Release. The Permittee agrees that it will never institute any action or suit at law or in equity against the City or any of its officers or employees, nor institute, prosecute, or in any way aid in the institution or prosecution of any claim, demand, or compensation for or on account of any damages, loss, or injury either to person or property, or both, known or unknown, past, present or future, arising from the Revocable Permit granted to Permittee. The Permittee hereby releases and absolves the City, its agents and employees, from any liability for any damage to any of the Facilities on the Property that may be caused by City construction or maintenance operations, or any other reason, including, but not limited to, removal, piling and plowing of snow, and from any liability for any injury or damage incurred by the Permittee in their use of the Facilities on the Property.
- 3.7. Indemnification. The Permittee expressly agrees to indemnify, defend and hold harmless the City and any of its officers or employees from any and all claims, demands, damages, court awards, including any costs and attorney's fees, that are or may be awarded as a result of any loss, injury or damage sustained or claimed to have been sustained by anyone, or any liability whatsoever from or, arising out of, the execution of this Revocable Permit by the Parties, or the presence of any Facilities or improvements by, or the use of the Facilities by the Permittee, its employees or agents.
- 3.8. Insurance. To assure the City that the Permittee is always capable of fulfilling specified indemnification obligations, the Contractor shall purchase and maintain insurance of the kind and in the amounts required by the City, from an insurer with an AM Best FSR rating of A- or higher as more particularly set forth on **Exhibit B**. Current proof of such insurance is attached at **Exhibit B**, incorporated by this reference. However, proof of insurance attached as **Exhibit B** shall not be deemed to limit or define obligations of Contractor as provided elsewhere in this Agreement, and Contractor should rely on its expertise to obtain additional insurance coverage needed for the City and Contractor in its performance hereunder.
- 3.9. Charter Provision. This Agreement is subject to the provisions of section 17.9 of the Charter for the City of Broomfield.
- 3.10. Other Conditions. The Permittee agrees to:

3.10.1. Maintain the private landscaping as follows:

- 3.10.1.1. The Permittee shall provide water as needed by way of an underground irrigation system.
- 3.10.1.2. The Permittee shall ensure the area around the plantings is kept free of weeds and maintained.
- 3.10.1.3. The Permittee shall ensure the crusher fines trail is kept free of weeds and maintained.
- 3.10.1.4. The Permittee shall ensure the turf area is mowed and maintained.
- 3.10.1.5. The Permittee shall remove the trees and plantings if they die. The Permittee is responsible for replacing plant material per the approved plan.
- 3.10.1.6. The Permittee shall ensure the emergency ADA access gate is in working condition and closed at all times unless in use.
- 3.10.1.7. The Permittee shall return the Property to its original condition if access is no longer required.

4.0 ASSIGNMENT. This Agreement shall not be assigned by Permittee without the prior written consent of the City, which may withhold its consent for any reason.

5.0 NOTICES. Any notice required or permitted by this Agreement shall be in writing and shall be deemed to have been sufficiently given for all purposes if personally served or if sent by certified mail or registered mail, postage and fees prepaid, addressed to the party to whom such notice is to be given at the address set forth below, or at such other addresses as have been previously furnished in writing, to the other party or parties.

City and County of Broomfield
ATTN: City Manager
Address: One DesCombes Drive
City: Broomfield
State: Colorado
Zip: 80020

Andreea Arvinte
Address: 1257 Clubhouse Drive
City: Broomfield
State: Colorado
Zip: 80020

Such notice shall be deemed to have been given when deposited in the United States Mail.

6.0 INTEGRATION AND AMENDMENT. This Agreement represents the entire agreement between the Parties and there are no oral or collateral agreements or understandings. This Agreement may be amended only by an instrument in writing signed by the parties. If any other provision of this Agreement is held invalid or unenforceable, no other provision shall be affected by such holding, and all of the remaining provisions of this Agreement shall continue in full force and effect.

- 7.0 COMPLIANCE WITH THE LAWS. The Permittee shall observe and comply with all applicable laws, including but not limited to federal, state and local laws, regulations, rules or ordinances that affect this Permit and those employed or engaged by the Permittee.
- 8.0 GOVERNING LAW. This Agreement shall be governed by the laws of the State of Colorado. Venue for any legal action related to this Agreement shall lie in the District Court, Broomfield County, Colorado.
- 9.0 WAIVER OF BREACH. A waiver by any party to this Agreement of the breach of any term or provision of this Agreement shall not operate or be construed as a waiver of any subsequent breach by either party.
- 10.0 BINDING EFFECT. This Agreement shall insure to the benefit or, and be binding upon, the parties, their respective legal representatives, successors, heirs, and assigns; provided, however, that nothing in this paragraph shall be construed to permit the assignment of this Agreement except as otherwise expressly authorized herein.
- 11.0 EXHIBITS. All exhibits referred to in this Agreement are by reference incorporated herein for all purposes.
- 12.0 PARAGRAPH CAPTIONS. The captions of the paragraphs are set forth only for the convenience and reference of the parties and are not intended in any way to define, limit, or describe the scope or intent of this Agreement.
- 13.0 ADDITIONAL DOCUMENTS OR ACTION. The parties agree to execute any additional documents or take any additional action that is necessary to carry out this Agreement.
- 14.0 NO THIRD PARTY BENEFICIARIES. This Agreement is intended to describe the rights and responsibilities only as to the parties hereto. This Agreement is not intended and shall not be deemed to confer any rights on any person or entity not named as a party hereto.
- 15.0 NO PRESUMPTION. The parties to this Agreement and their attorneys have had a full opportunity to review and participate in the drafting of the final form of this Agreement. Accordingly, this Agreement shall be construed without regard to any presumption or other rule of construction against the party causing the Agreement to be drafted.
- 16.0 EXECUTION; ELECTRONIC SIGNATURES. This Agreement may be executed in counterparts, each of which shall be deemed an original and all of which shall constitute but one and the same instrument. This Agreement shall not be binding

upon any Party hereto unless and until the Parties have executed this Agreement. The Parties approve the use of electronic signatures for execution of this Agreement.

[The remainder of this page is intentionally left blank.]

DATED: _____, 2024

THE CITY AND COUNTY OF BROOMFIELD,
a Colorado municipal corporation & body politic
and corporate of the State of Colorado

Mayor
One DesCombes Drive
Broomfield, CO 80020

ATTEST:

City and County Clerk

APPROVED AS TO FORM:

City and County Attorney's Office

Exhibit A

Facilities

[See attached.]

Legal Description (07-09-2024)

PARCEL A:

LOT 41, BLOCK 2 BROOMFIELD COUNTRY CLUB FOURTH FILING, CITY AND COUNTY OF BROOMFIELD, STATE OF COLORADO.

DEED RECORDED ON 02/17/2022 AT REC. NO. 2022001987

STATE PARCEL NUMBER: 157525306042

ADDRESS: 1257 Clubhouse Drive

LEGAL DESCRIPTION: Broomfield Country Club Filing No 4 Lot 41 Block 2

OWNER: Cristian Arvinte

ACREAGE: 0.19

COMPREHENSIVE PLAN DESIGNATION: Residential

APPLICABLE URBAN RENEWAL AREA/SUBAREA PLANS: N/A

ZONING: R-PUD - Broomfield Country Club PUD

(Attached Improvement Location Certificate for reference)

OUTLOT A:

Subd: BROOMFIELD COUNTRY CLUB FILING NO 4 TRACT/OUTLOT A

STATE PARCEL NUMBER: 157525306043

OWNER: City and County of Broomfield

EXHIBIT B
Insurance Requirements

**CITY and COUNTY of BROOMFIELD INSURANCE REQUIREMENTS - Including
GL/Auto/WC**

1. All insurers must be licensed or approved to do business within the State of Colorado.
2. Contractor/Vendor's insurance carriers should have an A.M. Best Company rating of at least A- VII.
3. Additional Insured - City and County of Broomfield, its officers, board members, agents, employees and volunteers acting within the scope of their duties for the City and County of Broomfield shall be named as Additional Insured on all Commercial General Liability and Automobile Liability Insurance policies (construction contracts require Additional Insured coverage for completed operations).
4. Primacy of Coverage – Coverage required of Contractors and Subcontractors shall be primary and non-contributory to any insurance carried by the City and County of Broomfield.
5. All subcontractors must meet the same insurance requirements for the Contract or Purchase Order unless Risk Management has approved a deviation.
6. Subrogation Waiver – All insurance policies required under this Contract maintained by Contractor or its Subcontractors shall waive all rights of recovery against City and County of Broomfield, its officers, board members, agents, employees and volunteers acting within the scope of their duties for the City and County of Broomfield.
7. Cancellation, Change in Coverage or Limits– The above insurance policies shall include provisions preventing cancellation, non-renewal, or reduction in coverage or limits of any insurance, without at least 30 days prior notice to Contractor/Vendor and Contractor/ Vendor shall forward such notice to within seven days of receipt of such notice.
8. Certificates – Contractor and all Subcontractors shall provide certificates showing insurance coverage required hereunder to the City and County of Broomfield within 5 days of:
 - a. the effective date of the Contract
 - b. the expiration date of any coverage
 - c. a request by the City and County of Broomfield
9. Separation of Insureds. All insurance policies shall include coverage for cross liability and contain a "Separation of Insureds" provision in the general liability policy.
10. City and County of Broomfield in no way warrants that the limits required herein are sufficient to protect the Contractor/Vendor from liabilities that may arise out of the performance of the work under this Contract by the Contractor, its agents, representative, employees or subcontractors. The Contractor is not relieved of any liability or other obligations assumed or pursuant to the Contract by reason of its failure to obtain or maintain insurance in sufficient amounts, duration or type.
11. All parties understand and agree that the City and County of Broomfield is relying on, and does not waive or intend to waive by any provision of this Contract, the monetary limitations, immunities, protections or any other rights provided by the Colorado Governmental Immunity Act.
12. The City and County of Broomfield reserves the right to negotiate additional specific insurance requirements at the time of the Contract.
13. The City and County of Broomfield and Contractor shall cooperate with each other in the collection of any insurance proceeds which may be payable in the event of any loss, including the execution and delivery of any proof of loss or other actions required to effect recovery.

Vendor/Contractor/Subcontractor shall obtain and maintain, at its own expense and for the duration of the contract including any warranty periods under which the Contract are satisfied, the following:

Insurance Requirements - GL/Auto/WC		
	COVERAGES AND LIMITS OF INSURANCE	Required
1.	<p>Commercial General Liability</p> <ul style="list-style-type: none"> Commercial General Liability insurance covering all operations by or on behalf of the contractor/vendor on an occurrence basis against claims for bodily injury, property damage (including loss of use), advertising liability, products and completed operations, and contractual liability. <p>Note: For contracts involving vendor/contractor contact with minors or at risk adults Sexual Abuse and Misconduct Coverage should be included in the coverage requirements.</p>	<p>Minimum Limits:</p> <ul style="list-style-type: none"> \$1,000,000 Each Occurrence \$2,000,000 General Aggregate (Per project aggregate for construction contracts) \$2,000,000 Products/Completed Operations Aggregate (for construction projects, this coverage should be maintained for a minimum of 3 years from the end of the project)
2.	<p>Automobile Liability</p> <ul style="list-style-type: none"> Automobile Liability Insurance covering any auto (including owned, hired and non-owned autos). 	<p>Minimum Limit:</p> <ul style="list-style-type: none"> \$1,000,000 each accident combined single limit. If hazardous materials are transported, an MCS 90 form shall be included on the policy.
3.	<p>Workers' Compensation</p> <ul style="list-style-type: none"> Workers' Compensation Insurance as required by State statute, covering all Vendors/Contractors employees acting within the course and scope of their employment. <p>Employer's Liability with:</p> <p>Note: This requirement shall not apply when a contractor or subcontractor is exempt under the Colorado Workers' Compensation Act AND when such contractor or subcontractor provides an appropriate sole proprietor letter.</p>	<p>Employer's Liability with Minimum Limits:</p> <ul style="list-style-type: none"> \$100,000 Each Accident \$100,000 Each Employee by Disease \$500,000 Disease Aggregate
<p>Additional Insured - The following shall be named an Additional Insured: The City and County of Broomfield, its officers, board members, agents, employees and volunteers acting within the scope of their duties for the City and County of Broomfield shall be named as Additional Insured on all Commercial General Liability, Umbrella Liability and Automobile Liability Insurance policies (construction contracts require Additional Insured coverage for completed operations). A Waiver of Subrogation is provided in favor of the Additional Insureds as respects to all policies.</p> <p>Certificate Holder is: City and County of Broomfield One DesCombes Drive Broomfield, CO 80020-2495 certificates@broomfield.org</p>		

Any deviations below the standards given above must be approved by the City and County of Broomfield's Risk Management office. Please direct any questions to RiskManagement@broomfield.org



Proposed Resolution Authorizing the Assignment of Broomfield Private Activity Bond (PAB) Allocation

Meeting	Agenda Group
Tuesday, September 10, 2024, 6:00 PM	Consent Items Item: 6H
Presented By	
Rachel King, Deputy Director, Economic Vitality & Development	
Community Goals	
<input checked="" type="checkbox"/> Thriving, Diverse, Safe and Welcoming Community	

Overview

[View Correspondence](#)

A resolution authorizing the assignment of the City and County of Broomfield's private activity bonds allocation for 2024 to the Colorado Housing and Finance Authority to support the proposed Harvest Hill 152 unit residential development, a 100% income-aligned rental housing project.

Attachments

[Memo.pdf](#)

[RESOLUTION 2024-128.pdf](#)

[2024-Assignment-of-Allocation-City.pdf](#)

[CERTIFICATE PAB Allocation_2024.pdf](#)

Summary

[View Correspondence](#)

Private Activity Bonds (PABs) are tax-exempt bonds that can be issued for specific purposes, including industrial development bonds, rental housing development, single-family mortgage revenue bonds, and exempt facilities. The federal government grants annual allocations of the bonding authority to states under the Tax Reform Act of 1986.

The Colorado PAB program allocates a portion of its PAB authority to cities and counties. The total state PAB available for direct allocations is \$734,701,250. Of that amount, \$4,791,378 is allocated to Broomfield based on population.

Broomfield has no pending use for its 2024 PAB allocation. Without action, Broomfield's allocation will automatically go to the statewide PAB pool and be allocated to other projects statewide unless the allocation is assigned to a specific project.

Income aligned housing developer, Ulysses Development Group has requested use of Broomfield's PAB allocation for 100% restricted rental multifamily development: Harvest Hill (152 units). This is allowed activity under the PAB program.

The Colorado Housing and Finance Authority (CHFA) has requested that Broomfield's PAB allocation be assigned to CHFA to issue bonds for the Harvest Hill development if they are successful in their funding requests with CHFA.

As a result of using the bonds and other public sources, a successful applicant/owner will be required to maintain the subject property for use as income-aligned housing for an additional 40 years.

If Ulysses is not successful in obtaining the requisite financing to commence the project, CHFA could use the volume cap to either support first-time homebuyer investment in Broomfield or other housing rental projects across the state.

Broomfield has assigned previous allocations to CHFA and the Metro Mortgage Assistance Program to be used in the first-time homebuyer programs.

Assigning the PAB allocation to CHFA also reduces the administrative burden of issuing the bonds and Broomfield will incur no liability.

Financial Considerations

The Program has no direct financial impact on the City and County of Broomfield as Broomfield does not receive the funds. Broomfield is provided access to issue bonds up to the allocated amount within CHFA.

Prior Council or Other Entity Actions

[Resolution No 2023-102](#)- Authorizing the Assignment of Broomfield's 2023 PAB Allocation

[Resolution 2022-122](#)- Authorizing the Assignment of the Broomfield's 2022 PAB Allocation

Boards and Commissions Prior Actions and Recommendations

N/A

Proposed Actions / Recommendations

If Council desires to approve the allocation, the appropriate motion is...

That Resolution 2024-128 be adopted.

Alternatives

Do not approve the assignment, in which case Broomfield's PAB allocation will go to the State of Colorado pool which is allocated within the state based on individual applications for qualifying projects.

RESOLUTION NO.2024-128

A Resolution Authorizing the Assignment of Broomfield’s 2024 Private Activity Bond Allocation to the Colorado Housing and Finance Authority

Recitals.

Whereas, pursuant to the Private Activity Bond Ceiling Act, constituting Title 24, Article 32, Part 17, Colorado Revised Statutes (the "Allocation Act"), the City and County of Broomfield, Colorado (the "City") has received a direct allocation of the State of Colorado’s Private Activity Bond Ceiling (the "2024 Allocation") in the amount of \$4,791,378; and

Whereas, the Colorado Housing and Finance Authority has requested that the City assign all of the 2024 Allocation in the amount of \$4,791,378 (the "Assigned Allocation") to the Colorado Housing and Finance Authority pursuant to Section 24-32-1706 of the Allocation Act, to be used to issue bonds to finance a 100% affordable rental multi-family development, the Harvest Hill project, located near US Hwy 36 and State Highway 128; and

Whereas, the City desires to assign the Assigned Allocation to the Colorado Housing and Finance Authority; and

Whereas, there has been presented to the City Council the form of an assignment of allocation (the "Assignment").

Now, therefore, be it resolved by the City Council of the City and County of Broomfield, Colorado:

Section 1.

- A. The City hereby authorizes the Assignment of the Assigned Allocation to the Colorado Housing and Finance Authority for use as described above.
- B. The form, terms, and provisions of the Assignment are approved and the Mayor and the Office of the City and County Clerk of the City are authorized and directed to execute and deliver the Assignment, with such technical variations, additions, or deletions therein as the City and County Attorney may deem necessary or appropriate and not inconsistent with the approval thereof by this resolution. The execution of the Assignment shall be conclusive evidence of the approval by the City of such document in accordance with the terms hereof.
- C. The officers of the City shall take such other steps or actions necessary or reasonably required to carry out the terms and intent of this resolution and the Assignment.
- D. If any section, paragraph, clause, or provision of this resolution shall for any reason be held to be invalid or unenforceable, the invalidity or unenforceability of such section, paragraph, clause, or provision shall not affect any of the remaining provisions of this resolution.
- E. All actions not inconsistent with the provisions of this resolution heretofore taken by the Council and the officers of the City directed toward the assignment of the Assigned Allocation and the authorization of the Assignment hereby are ratified, approved, and confirmed.

Section 2.

This resolution shall be in full force and effect upon its passage and approval by the Council.

Approved on September 10, 2024.

The City and County of Broomfield, Colorado

Mayor

Attest:

Office of the City and County Clerk

Approved As To Form:

City and County Attorney

KKH



assignment of allocation - city

Multifamily Housing Facility Bonds/Single Family Mortgage Revenue Bonds

This Assignment of Allocation (the "Assignment"), dated this 10th day of September, 2024, is between the City of Broomfield, Colorado (the "Assignor" or the "Jurisdiction") and Colorado Housing and Finance Authority (the "Assignee").

WITNESSETH:

WHEREAS, the Assignor and the Assignee are authorized and empowered under the laws of the State of Colorado (the "State") to issue revenue bonds for the purpose of providing single-family mortgage loans to low- and moderate-income persons and families; and

WHEREAS, the Internal Revenue Code of 1986, as amended (the "Code"), restricts the amount of tax-exempt bonds ("Private Activity Bonds") which may be issued in the State to finance such projects and for certain other purposes (the "State Ceiling"); and

WHEREAS, pursuant to the Code, the Colorado legislature adopted the Colorado Private Activity Bond Ceiling Allocation Act, Part 17 of Article 32 of Title 24, Colorado Revised Statutes (the "Allocation Act"), providing for the allocation of the State Ceiling among the Assignee and other governmental units in the State, and further providing for the assignment of allocations from such other governmental units to the Assignee; and

WHEREAS, pursuant to an allocation under Section 24-32-1706 of the Allocation Act, the Assignor has an allocation of the 2024 State Ceiling for the issuance of a specified principal amount of Private Activity Bonds prior to September 15, 2024, (the "2024 Allocation"); and

WHEREAS, the Assignor has determined that, in order to increase the availability of adequate affordable rental housing for low- and moderate-income persons and families within the Jurisdiction, Colorado and elsewhere in the State, it is necessary or desirable to provide for the utilization of all or a portion of the 2024 Allocation; and

WHEREAS, the Assignor has determined that the 2024 Allocation, or a portion thereof, can be utilized most efficiently by assigning it to the Assignee to issue Private Activity Bonds for the purpose of financing one or more multifamily rental housing projects for low- and moderate-income persons and families or to issue Private Activity Bonds for the purpose of providing single-family mortgage loans to low- and moderate-income persons and families ("Revenue Bonds"), and the Assignee has expressed its willingness to attempt to issue Revenue Bonds with respect to the 2024 Allocation assigned herein; and

WHEREAS, the City Council of the Assignor has determined to assign to the Assignee all or a portion of its 2024 Allocation, and the Assignee has agreed to accept such assignment, which is to be evidenced by this Assignment.

NOW, THEREFORE, in consideration of the premises and the mutual promises hereinafter set forth, the parties hereto agree as follows:

1. The Assignor hereby assigns to the Assignee \$^{4,791,378}_____ of its 2024 Allocation (the "Assigned Allocation"), subject to the terms and conditions contained herein. The Assignor represents that it has received no monetary consideration for said assignment.
2. The Assignee hereby accepts the assignment to it by the Assignor of the Assigned Allocation, subject to the terms and conditions contained herein. The Assignee agrees to use its best efforts to issue and sell Revenue Bonds in an aggregate principal amount equal to or greater than the Assigned Allocation, in one or more series, and to make proceeds of such Revenue Bonds available from time to time for a period of one (1) year from the date of this Assignment to finance multi-family rental housing projects located in the Jurisdiction, or to issue Revenue Bonds for the purpose of providing single-family mortgage loans to low- and moderate income persons and families in the Jurisdiction.
3. The Assignor hereby consents to the election by the Assignee, if the Assignee in its discretion so decides, to treat all or any portion of the Assigned Allocation as an allocation for a project with a carryforward purpose or to make a mortgage credit certificate election, in lieu of issuing Revenue Bonds.
4. The Assignor and Assignee each agree that it will take such further action and adopt such further proceedings as may be required to implement the terms of this Assignment.
5. Nothing contained in this Assignment shall obligate the Assignee to finance any particular multi-family rental housing project located in the Jurisdiction or elsewhere or to finance single-family mortgage loans in any particular amount or at any particular interest rate or to use any particular percentage of the proceeds of its Revenue Bonds to provide mortgage loans or mortgage credit certificates to finance single-family housing facilities in the Jurisdiction, provided that any Revenue Bond proceeds attributable to the Assigned Allocation shall be subject to paragraph 2 above.
6. This Assignment is effective upon execution and is irrevocable.
7. Counterparts. This Assignment may be executed in one or more counterparts, each of which will be deemed an original, but all of which together will constitute one and the same instrument. Delivery of an executed counterpart of a signature page of this Assignment by electronic image scan transmission will be effective as delivery of a manually executed counterpart of the Assignment.

IN WITNESS WHEREOF, the parties hereto have duly executed this Assignment on the date first written above.

City of _____, Colorado

By: _____

Name: _____

Title: _____

COLORADO HOUSING AND FINANCE
AUTHORITY

By: _____

Name: _____

Title: _____

CERTIFICATE OF THE CITY OF BROOMFIELD, COLORADO
CONCERNING ASSIGNMENT OF
PRIVATE ACTIVITY BOND VOLUME CAP ALLOCATION

I, the undersigned, hereby certify that I am a duly chosen, qualified and City Attorney of the City of Broomfield, Colorado (the "City"), and that:

1. The City is a public body politic and corporate, duly organized and existing under the constitution and laws of the State of Colorado.

2. The City has been previously notified that, pursuant to Section 24-32-1706 of the Colorado Private Activity Bond Ceiling Allocation Act, Part 17 of Article 32 of Title 24, Colorado Revised Statutes (the "Allocation Act"), it has an allocation of the State ceiling (as defined in the Allocation Act) for 2024 in the amount of \$4,791,378 (the "2024 Allocation").

3. Attached hereto as Exhibit A is a true and correct copy of a resolution and the related minutes thereto (the "Resolution") authorizing the assignment to the Colorado Housing and Finance Authority (the "Authority") of all or a portion of the 2024 Allocation in an amount equal to \$4,791,378 (the "Assigned Allocation"), and authorizing the execution and delivery of an Assignment of Allocation dated as of September 10, 2024 (the "Assignment of Allocation") between the City and the Authority in connection therewith, which Resolution was duly adopted by the City Council of the City (the "City Council") at a meeting thereof held on September 10, 2024, at which meeting a quorum was present and acting throughout and which Resolution has not been revoked, rescinded, repealed, amended or modified and is in full force and effect on the date hereof.

4. The meeting of the City Council at which action has been taken with respect to the Assignment of Allocation was a regular meeting properly called and open to the public at all times.

5. With respect to the Assigned Allocation, the City has not heretofore: (a) issued private activity bonds; (b) assigned the Assigned Allocation to another "issuing authority," as defined in the Allocation Act; (c) made a mortgage credit certificate election; or (d) treated the Assigned Allocation as an allocation for a project with a carryforward purpose, as defined in the Allocation Act.

6. The Assignment of Allocation, attached hereto as Exhibit B, is in the form presented to and approved by the City Council at the meeting thereof held on September 10, 2024.

7. On or before the date hereof, counterparts of the Assignment of Allocation were officially executed by the Mayor and the City Clerk of the City. On the date of such signing, such persons were the duly sworn, qualified and acting officers of the City authorized to execute the Assignment of Allocation and holding the offices of the Mayor and City Clerk, respectively.

8. The City has authorized the execution, delivery and due performance of the Assignment of Allocation, and the execution and delivery of the Assignment of Allocation and the compliance by the City with the provisions thereof, will not, to the best of my knowledge, conflict with or constitute on the part of the City a breach of or a default under any existing Colorado law, City resolution, court or administrative regulation, decree or order or any agreement or other instrument to which the City is subject or by which it is bound.

9. To the best of my knowledge, there does not exist any action, suit, proceeding or investigation pending, or threatened against the City, contesting (a) the corporate existence of the City, (b) the title of its present officers or any of them to their respective offices, including, without limitation, the members of the City Council, (c) the validity of the Assignment of Allocation or (d) the power of the City to execute, deliver or perform the Assignment of Allocation.

10. No referendum petition has been filed concerning the Resolution; and to the best of my knowledge none is being circulated or planned for circulation.

WITNESS my hand and the seal of the City this Broomfield 2024.

City Attorney

(SEAL)



Proposed Resolution No. 2024-138 in Support of the Regional Transportation District's (RTD) 2024 Ballot Initiative Continuing RTD's Exemption from TABOR Cap Limitations

Meeting	Agenda Group
Tuesday, September 10, 2024, 6:00 PM	Consent Items Item: 6I
Presented By	
Danee Brouillard	
Community Goals	

Overview

[View Correspondence](#)

The [Regional Transportation District](#) (RTD) provides public transportation in eight counties including all of Boulder, Denver, and Jefferson counties, most of Broomfield and parts of Adams, Arapahoe, and Douglas Counties, and a small portion of Weld County. Overall,

In 1999, district voters exempted RTD from TABOR's revenue and spending limitations through the period required to pay bond debt but not past 2026. The bond debt will be fully repaid in November 2024. To continue the 1999 voter authorization and extend the exemption past 2026, RTD has proposed a ballot initiative for the November 2024 ballot to continue to collect, retain, and spend all revenues without regard to TABOR limitations. Proposed Resolution 2024- 138, if approve, would formalize Council's support of this ballot initiative.

Attachments

[Memo_ Resolution 2024-138 in Support of the Regional Transportation District's \(RTD\) 2024 Ballot Initiative Continuing RTD's Exemption from TABOR Cap Limitations.pdf](#)

[Resolution No. 2024-138 in Support of the Regional Transportation District's \(RTD\) 2024 Ballot Initiative Continuing RTD's Exemption from TABOR Cap Limitations.pdf](#)

Summary

[View Correspondence](#)

The Northwest Mayors & Commissioners Coalition requested Broomfield consider endorsing the ballot initiative the [Regional Transportation District](#) (RTD) Board has proposed for the November 2024 ballot to continue to collect, retain, and spend all revenues without regard to TABOR limitations. If Council does desire to endorse this ballot issue then, Proposed Resolution 2024- 138 would formalize the Council's support of this ballot initiative.

RTD provides public transportation in eight counties including all of Boulder, Denver, and Jefferson counties, most of Broomfield and parts of Adams, Arapahoe, and Douglas Counties, and a small portion of Weld County. Overall, RTD serves over 3.08 million people located within 2,342 square miles and services include bus, rail, shuttles, ADA paratransit services, demand responsive services like FlexRide, etc.

In 1999, district voters exempted RTD from TABOR's revenue and spending limitations through the period required to pay bond debt but not past 2026. The bond debt will be fully repaid in November 2024, which will subject all of RTD's TABOR-applicable revenue to TABOR's growth limitations beginning in 2025. To continue the 1999 voter authorization and extend the exemption past 2026, RTD has proposed a ballot initiative for the November 2024 ballot to continue to collect, retain, and spend all revenues without regard to TABOR limitations.

Background: TABOR is a 1992 voter-approved amendment to the Colorado Constitution that generally limits the amount of revenue Colorado governments can retain and spend and requires voter approval to increase taxes or retain excess revenues above certain limits that TABOR sets, as well as to issue certain new multi-year financial obligations such as bond debt.

For RTD, the TABOR annual revenue growth limit is determined by the sum of the change in the Denver-Aurora-Lakewood Consumer Price Index (CPI) plus the net change in new property construction. Revenues collected in a fiscal year that exceed these limits must be returned to taxpayers.

In 1995, district voters exempted RTD from TABOR's revenue and spending limitations through 2005. In 1999, district voters approved another exemption of RTD from TABOR's revenue and spending limitations through the period required to pay bond debt but not past 2026. This voter-approved structure includes the 0.6% RTD sales and use tax, and is referred to as the Base System. The Base System bond debt will be fully repaid in November 2024, which will subject all of RTD's TABOR-applicable revenue, except the 0.4% sales and tax levied for RTD's FasTracks Project, to TABOR's growth limitations beginning in 2025.

These revenue growth limitations will likely adversely impact RTD's future funding availability. RTD's 2024 budget revenues are \$1,352.1 million of which \$668.5 million or 49.4% is subject to TABOR. If RTD's TABOR exemption sunsets, it is likely the RTD will need to reduce services, potentially impacting transit services available in Broomfield and services that connect Broomfield to the region.

In June 2024, the RTD Board of Directors adopted a resolution to submit a ballot question to eligible voters that would allow RTD to remain exempt TABOR. Pursuant to Council rules, approval of proposed Resolution 2024-138 requires two-thirds vote of the majority of Council.

RTD's Ballot question*:

BALLOT ISSUE NO. [___] WITHOUT IMPOSING ANY NEW TAX OR INCREASING ANY TAX RATE, SHALL THE REGIONAL TRANSPORTATION DISTRICT'S ("RTD") AUTHORIZATION TO COLLECT, RETAIN AND SPEND ALL REVENUES IT RECEIVES FROM ALL SOURCES, INCLUDING ITS SALES TAX REVENUES, GRANT FUNDS AND OTHER MONEYS LAWFULLY RECEIVED BY RTD FROM THE STATE OF COLORADO OR ANY OTHER SOURCE, ORIGINALLY APPROVED BY THE VOTERS IN 1999, BE CONTINUED TO PERMIT RTD TO RETAIN REVENUE NECESSARY TO PROVIDE VITAL RTD SERVICES, INCLUDING BUT NOT LIMITED TO: • PROVIDING TRANSPORTATION CHOICES TO LOCAL RESIDENTS BY MAINTAINING AND GROWING CURRENT LEVELS OF BUS, AND RAIL SERVICES; • REPAIRING AND IMPROVING RAIL LINES, BUSES, BUS STOPS AND STATIONS AND OTHER INFRASTRUCTURE TO PRESERVE THE PUBLIC'S INVESTMENT IN TRANSIT; • MAINTAINING THE AVAILABILITY OF SERVICES FOR PEOPLE WITH DISABILITIES; • CONTINUING TO PROVIDE CLEANER, MORE EFFICIENT METHODS OF TRANSPORTATION OTHER THAN DRIVING ON ROADS AND HIGHWAYS; AND • PROVIDING TRANSPORTATION SERVICES FOR YOUTH 19 YEARS OF AGE OR YOUNGER AT REDUCED OR NO FARES; WITH ALL FUNDS SUBJECT TO INDEPENDENT AUDIT AND OVERSEEN BY THE ELECTED RTD BOARD; AS A VOTER APPROVED REVENUE CHANGE AND EXEMPTION FROM ANY REVENUE AND SPENDING LIMITATIONS UNDER ARTICLE X, SECTION 20 OF THE COLORADO CONSTITUTION?

*The issue number has not been assigned at this time.

Financial Considerations

Minimal. There may be some costs associated with communication and marketing in addition to the staff time preparing the documents.

Prior Council or Other Entity Actions

In the past, Council has taken positions on ballot initiatives/questions and legislation consistent with Council's Rules of Procedures.

Boards and Commissions Prior Actions and Recommendations

N/A

Proposed Actions / Recommendations

If Council desires to support the ballot initiative as outlined above, the appropriate motion is...
That Resolution 2024-138 be adopted.

Alternatives

Council may take no action or amend this resolution to oppose this legislation.

RESOLUTION NO. 2024 - 138

A Resolution in Support of the Regional Transportation District's (RTD) 2024 Ballot Initiative
Continuing RTD's Exemption from TABOR Cap Limitations

Whereas, the Regional Transportation District (RTD) provides public transportation in eight counties including all of Boulder, Denver, and Jefferson counties, most of Broomfield and parts of Adams, Arapahoe, and Douglas Counties, and a small portion of Weld County.

Whereas, RTD serves over 3.08 million people located within 2,342 square miles, and services include bus, rail, shuttles, ADA paratransit services, demand-responsive services like FlexRide, etc.

Whereas, in 1999, district voters exempted RTD from TABOR's revenue and spending limitations through the period required to pay bond debt issued to finance the construction of certain light rail lines but not past 2026.

Whereas, the bond debt will be paid in November 2024 therefore sunsetting the 1999 district voter approval of the TABOR exemption.

Whereas, if RTD's TABOR exemption sunsets, it is likely the RTD will need to reduce services.

Whereas, to continue the 1999 voter authorization, RTD has proposed a ballot initiative to continue to collect, retain, and spend revenues without regard to TABOR limitations.

Now, therefore, be it resolved by the City Council of the City and County of Broomfield:

The Broomfield City Council supports the Regional Transportation District's November 2024 ballot initiative continuing RTD's exemption from the TABOR cap limitations.

This resolution is effective upon its approval by the City Council.

Approved on September 10, 2024.

The City and County of Broomfield, Colorado

Mayor

Attest:

Office of the City and County Clerk

Approved as to form:

NCR

City and County Attorney



Request for Executive Session Regarding JPPHA

The City and County Attorney is requesting an executive session to discuss the Jefferson Parkway Public Highway Authority to receive legal advice and obtain instructions to negotiators permitted under C.R.S. § 24-6-402(4)(b) and (e).

Meeting	Agenda Group
Tuesday, September 10, 2024, 6:00 PM	Consent Items Item: 6J
Presented By	
Nancy Rodgers, City and County Attorney	
Community Goals	

Overview

[View Correspondence](#)

The executive session regarding Jefferson Parkway Public Highway is proposed for September 17, 2024 to take place immediately following the study session. In the event the executive session is not needed, it will be canceled. An executive session is permitted under C.R.S. § 24-6-402(4)(b) and (e).

Attachments

[Memo - Request for Executive Session for JPPHA 9-10-2024](#)

Summary

[View Correspondence](#)

The City and County Attorney requests scheduling an executive session for the purpose of obtaining instruction to negotiators and providing legal advice regarding the Jefferson Parkway Public Highway Authority (JPPHA). The executive session is proposed for September 17, 2024 to take place immediately following the study session. In the event the executive session is not needed, it will be canceled.

An executive session is permitted under C.R.S. § 24-6-402(4)(b) and (e) and requires an affirmative vote of 2/3rds of the quorum present.

The open meetings provision of the Colorado Sunshine Act of 1972 (Act) requires that any local public body announce in public the topic for discussion for the executive session. In addition, the local public body must include the specific citation in the Act that authorizes the local public body to meet in executive session. The local public body must also identify the particular matter to be discussed in as much detail as possible without compromising the purpose for which the executive session is authorized. C.R.S. § 24-6-402(4).

Executive sessions are electronically recorded. The record of an executive session must also state the specific citation in the Act authorizing the executive session. Portions of an executive session that are purely for purposes of obtaining legal advice do not need to be recorded.

Financial Considerations

N/A

Prior Council or Other Entity Actions

N/A

Boards and Commissions Prior Actions and Recommendations

N/A

Proposed Actions / Recommendations

Based on the above, it is recommended that Council approve, by 2/3rds vote, the following motion ...

That the City Council schedule an executive session to be held on September 17, 2024 immediately after Council's study session, for the purpose of obtaining instruction to negotiators and providing legal advice and regarding the Jefferson Parkway Public Highway Authority as permitted by C.R.S. § 24-6-402(4)(b) and (e).

Alternatives

Deny motion and not schedule the executive session.



Request to Reschedule Executive Session Regarding the City and County Manager's Annual Performance Review

Request for Executive Session per C.R.S. § 24-6-402(4)(f)(I)

Meeting	Agenda Group
Tuesday, September 10, 2024, 6:00 PM	Consent Items Item: 6K
Presented By	
Niki Macklin, HR Director	
Community Goals	

Overview

[View Correspondence](#)

Council had previously approved an executive session to be held on August 27, 2024, as part of Council's annual review and evaluation of the City and County Manager. Due to illness, that executive session was canceled and Council wishes to reset it. Rescheduling the executive session must be done with a new motion under state law. Therefore, the executive session has been proposed to be rescheduled and held on September 12, 2024, immediately following Council's Special Study Session.

Attachments

[Memo - Request to Reschedule Executive Session Regarding the City and County Manager's Annual Performance Review.pdf](#)

Summary

[View Correspondence](#)

Council had previously approved an executive session to be held on August 27, 2024, as part of Council's annual review and evaluation of the City and County Manager. Due to illness, that executive session was canceled and Council wishes to reset it. Rescheduling the executive session must be done with a new motion under state law. Therefore, the executive session has been proposed to be rescheduled and held on September 12, 2024, immediately following Council's Special Study Session. This executive session is permitted under C.R.S. § 24-6-402 (4)(f)(I) - Personnel Matters. An executive session requires an affirmative vote of two-thirds of the quorum present.

The open meetings provision of the Colorado Sunshine Act of 1972 (Act) requires that any local public body announce in public the topic for discussion for the executive session. In addition, the local public body must include the specific citation in the Act that authorizes the local public body to meet in executive session. The local public body must also identify the particular matter to be discussed in as much detail as possible without compromising the purpose for which the executive session is authorized. C.R.S. § 24-6-402(4).

The executive session will be electronically recorded. The record of an executive session must also state the specific citation in the Act authorizing the executive session. Portions of an executive session that are purely for purposes of obtaining legal advice do not need to be recorded.

Financial Considerations

N/A

Prior Council or Other Entity Actions

Prior executive sessions in the last twelve months regarding personnel matters involving the City and County Manager's Annual Performance review have been held on [September 12, 2023](#) and [September 19, 2023](#), [January 9, 2024](#), and [August 13, 2024](#).

Boards and Commissions Prior Actions and Recommendations

N/A

Proposed Actions / Recommendations

Based on the above, it is recommended...

That an Executive Session be held on September 12, 2024, immediately following Council's Special Study Session, for the purpose of discussing personnel matters related to the City and County Manager's annual review, as permitted by CRS § 24-6-402(4)(f)(I).

Alternatives

Deny the motion and not schedule the executive session.



City of Broomfield

City Council Regular Meeting

Public Hearing - Ordinance to Implement Contracted Waste Hauling Services - Second Reading and Proposed Resolution Approving an Agreement with Waste Connections for Contracted Waste Hauling

Meeting	Agenda Group	
Tuesday, September 10, 2024, 6:00 PM	Action Items	Item: 7A
Presented By		
Ken Rutt		
Community Goals		
<input checked="" type="checkbox"/> Growing Greener		

Overview

[View Correspondence](#) and visit BroomfieldVoice.com (link to project page OR remove if not applicable)

The first item for Council's consideration is Ordinance No. 2242, which amends the Broomfield Municipal Code to allow the City to contract with a licensed hauler to provide residential waste collection services. The second item for Council's consideration is Resolution No. 2024-120 which, if approved, would authorize a contract with Waste Connections of Colorado, Inc. to provide the residential waste collection services.

Attachments

[Memo for Consideration of a Contracted Waste Hauling Ordinance and a Resolution Approving an Agreement with Waste Connections for Contracted Waste Hauling.pdf](#)

[Ordinance No. 2242.pdf](#)

[Resolution 2024-120.pdf](#)

[Agreement for City-Contracted Residential Waste Services - Waste Connections of Colorado, Inc. - CCOB Final For Signature 8.14.2024 - No HOAs - Executed by Waste Connections.pdf](#)

Summary

[View Correspondence](#)

This matter involves two separate but related items on city-contracted waste hauling services. The [Contracted Residential Waste Services program](#) (formerly Universal Waste Collection), if adopted as presented, would allow for the City and County of Broomfield to contract with a single trash hauler to provide residential waste services to residents.

The first item for Council's consideration is Ordinance No. 2242, which amends the Broomfield Municipal Code to allow the City to contract with a licensed hauler to provide residential waste collection services. The second item for Council's consideration is Resolution No. 2024-120 which, if approved, would authorize a contract with Waste Connections of Colorado, Inc. to provide the residential waste collection services.

The Contracted Residential Waste Services program is designed to increase waste diversion. This program is aligned with the community's "growing greener" goal by reducing Broomfield's environmental footprint by diverting materials from landfills. The community's goal is 50% waste diversion by 2025. Broomfield's waste diversion rate has remained between 21% and 25% since 2020. Implementing the Contracted Residential Waste Services program with non-homeowners association (non-HOA) residents is expected to increase waste diversion in Broomfield by 2% to 4%. In addition to waste diversion benefits, the Contracted Residential Waste Services program will reduce the number of heavy trucks on Broomfield streets and thereby reduce associated air and noise pollution, potential safety concerns, and excess wear on pavement. This program will extend the benefit of bulk pricing to residents who do not live in an HOA.

Ordinance No. 2242 - Amendments to the Code

Ordinance No. 2242 changes the Broomfield Municipal Code to allow the City to contract with a licensed hauler to provide residential waste collection services. Ordinance No. 2242 includes the following updates:

1. Allows the City to contract residential waste hauling services for residents of single-family homes and multi-family dwellings with seven or fewer units;
2. Allows the City to charge residents a minimum service or opt-out fee if they do not wish to participate in the program;
3. Requires non-exempted residents to separate recyclable materials from trash;
4. Exempts HOAs that contract for trash and recycling services without requiring them to pay a minimum service or opt-out fee.

Ordinance No. 2242 does not require haulers to use volume-based pricing (or "pay-as-you-throw") to obtain a license to operate in Broomfield.

Ordinance No. 2242 takes effect only if Council approves a residential waste services contract with a hauler.

If Ordinance No. 2242 is not approved, that will discontinue exploration of city-contracted residential waste collection services pending further direction from Council and Resolution No. 2024-120 will not be considered.

Resolution No. 2024-120 - Waste Hauler Contract Overview

At the October 10, 2023, City Council meeting, Council approved [Resolution No. 2023-123](#) directing staff to issue a “request for proposals” for City-Contracted Residential Waste Hauling Services. After a competitive proposal review and vendor selection process, staff has negotiated a proposed contract with Waste Connections of Colorado to provide trash and recycling services to eligible Broomfield residents.

HOAs that contract for trash and recycling services may join the city contract if they choose but will not be required to do so. Approximately 60% of Broomfield parcels eligible for services under this contract reside within HOAs.

Fees. The proposed contract is designed with volume-based pricing to improve waste diversion. Residents will pay a monthly fee based on the size of the trash cart they select. The monthly fee for Medium trash cart service is 1.85 times the monthly fee for Small trash cart service and Large trash cart service is 2.85 times the monthly fee for Small trash carts (see table below for fees). A Large (96-gal) recycling cart is included at no additional cost and emptied every other week. Seniors (age 65+) and veterans get a 10% discount on prices listed below.

Summary of Fees for Weekly Trash and Every Other Week Recycling Services (All service levels include a large recycling cart)	
<u>Trash Cart Size</u>	<u>Service Fee</u>
32-gallon (Small Cart)	\$10.50 per month
64-gallon (Medium Cart)	\$19.43 per month
96-gallon (Large Cart)	\$29.93 per month
<u>Other Fees</u>	
Minimum Service Fee (to opt-out)	\$10.50 per month
Extra Bags (Trash)	\$3.50 per bag
Extra Recycling cart	\$4.00 per month
Bulky Item Pickup Fee	\$25.00 per item

Minimum Service Fee: Residents who do not want to participate may opt-out and pay a monthly minimum service fee of \$10.50. HOAs that contract for trash and recycling services may choose to join the city contract or maintain their own contract without paying minimum service fees. Based on surrounding community participation in similar waste collection programs, the projected participation rate of 95-97%, and the monthly Small cart service fee of \$10.50 under the proposed contract, staff estimates that approximately 430 households will be billed the minimum service fee per month, with estimated total annual offsetting revenue of \$32,700 to \$54,440. The goal of the minimum service fee is to create a high participation rate so that the City can obtain the best pricing from the hauler. Any revenue from the fees will be used to support waste diversion efforts in the City.

Comparison to current rates: Results of the 2023 Broomfield Voice Universal Waste Collection Survey (900 respondents) showed that 59% of respondents living outside HOAs pay \$30 a month or more for trash and

recycling services. With the proposed fees, many non-HOA residents will pay fees equivalent or lower for Large trash cart service to what they pay now. Many non-HOA residents will have the opportunity to lower their monthly costs by selecting a Small or Medium trash cart service level and by recycling more. Some will pay higher fees to keep the same Large trash cart service, which will particularly impact large families if they currently pay less than \$30 per month for a Large cart.

More detail about the proposed contract can be found starting on page 6 of this memo ([click here to go to page 6](#)).

If approved, the Contracted Residential Waste Services program is expected to start in the second quarter of 2025. If not approved, that will discontinue exploration of city-contracted residential waste collection services and Ordinance No. 2242 will not go into effect at this time. Staff would need additional direction if the Council desires staff to continue to pursue a city-contracted residential waste collection services contract anytime before July 31, 2025, as allowed by Ordinance No. 2242.

Financial Considerations - Ordinance No. 2242

No funds are requested to implement this ordinance. It is only effective if/when a city contract is approved. On its own, the ordinance has limited financial impact on the City and any revenue received would be used to support waste diversion efforts in the City.

Financial Considerations - Resolution No. 2024-120

Two new FTEs are required to start the program. After finalizing the proposed contract, Public Works and Finance staff evaluated projected staffing workloads and options available to implement this new service level. The FTE needs presented in the [August 13, 2024 memo](#) have been revised downward to two (2) FTE Limited Term Appointments that would be added to the budget through a 2025 Budget Revision. Subsequent review and analysis will determine future requests related to these positions:

- **Revenue Technician** - The workload required for manually billing the minimum service fee for an estimated 430 households per month is more than the billing team can absorb and requires additional FTE. Approximately 50% of the new Revenue Technician's time would go to minimum service fee billing for the proposed contract, and the remainder would go to answering questions related to new utility rates.
- **Recycling Technician II** - Staff impacts of the proposed contract other than minimum service fee billing include ongoing and ad hoc coordination with the contracted hauler (to address contamination issues and for events, street closures, and weather events), reviewing data and reports, assessing performance, responding to questions and concerns from residents (high volume expected), and other contract management tasks.

Existing staff does not have capacity to absorb the expected workload at service levels expected by Broomfield residents and also continue to fulfill other waste diversion responsibilities such as staffing the recycling center; running spring clean-up; household hazardous waste disposal, and paper shredding events; planning and implementing outreach and education; work with Broomfield schools; increasing waste diversion in Broomfield municipal operations; and implementing additional strategies from the Zero Waste plan (e.g. policy and programs to increase access to recycling in multifamily units & businesses; increase options for hard to recycle materials). Staff estimate that 60-70% of this Recycling Technician's time will go to answering questions and troubleshooting with residents. The remaining time will be spent assisting with events and staffing the Recycling Center.

As shown in the sources and uses of funds summary below, the education and outreach costs associated with the project can be completed within the 2025 budgeted amount. The cost related to the two limited term appointments would not be covered by the revenue generated by the program.

Sources and Uses of Funds - Budgeted	Amount
Fund 02-55200-53xxx (2025 budget)	\$158,208
Outreach and education (advertising, printing, postage, events)	
	-\$25,000
Projected Balance	\$133,208

Sources and Uses of Funds - Unbudgeted	Amount
Minimum anticipated revenue from Minimum Service Fee (Opt-Out Fee)	\$32,700
Estimated cost	
Revenue Technician (1 FTE) 12-month Limited term appointment	-\$69,481
Recycling Technician II (1 FTE) 12-month Limited term appointment	-\$88,270
Estimated 12-month FTE cost	\$157,751
Projected Balance	-\$125,051

Prior Council or Other Entity Actions

February 11, 2020: Council approved [Resolution No. 2020-65](#), adopting Zero Waste Goals.

September 22, 2020: Council approved [Resolution No. 2020-169](#), adopting Greenhouse Gas Reduction as a Guiding Principle and Supporting the Creation of a Greenhouse Gas Reduction Plan.

October 9, 2020: Broomfield received an award ([letter](#)) of \$90,000 from CDPHE’s “FWRD” grant program to hire a consultant to draft a zero-waste plan.

January 12, 2021: Council approved [Resolution No. 2021-5](#) approving a consulting agreement with Abbe & Associates, LLC (AKA Zero Waste Associates) in the amount of \$85,300 for professional services in regard to increasing recycling, composting, and waste diversion in Broomfield.

January 18, 2022: Staff was directed to prepare a ballot question to authorize the City & County to adopt a community recycling and composting ordinance and to contract with one or more private waste haulers for waste removal services, commonly known as Universal Collection.

July 26, 2022: Council rejected [Proposed Resolution No. 2022-94](#) adding a ballot question to the November 2022 election concerning Universal Collection in Broomfield, and directed staff to facilitate more robust

community engagement and to prepare a study session to address the concerns and questions of Council and the public.

April 18, 2023: Council directed staff to pursue a Contracted Residential Waste Services (Universal Waste Collection) program including trash collection with volume-based/PAYT pricing and recycling services bundled at no additional cost, and a Residential Recycling and Composting Ordinance focused on hauler licensing requirements. Council further directed staff on key elements of the program, including requirement of an opt-out fee for households, exploration of multiple options for organics collection, and that HOAs should participate in the program. [View the Study Session memo here.](#)

October 10, 2023: Council approved [Resolution No. 2023-123](#) directing staff to issue a “request for proposals” for City-Contracted Residential Waste Hauling Services.

April 16, 2024, and May 7, 2024, Executive Session for Legal Advice and Direction to Negotiators.

August 13, 2024: Council approved, on first reading, [Ordinance No. 2242](#).

Boards and Commissions Prior Actions and Recommendations

August 12, 2024: Staff presented Ordinance No. 2242 for the Advisory Committee for Environmental Sustainability’s (ACES) review. ACES recommended that Council approve Ordinance No. 2242 to establish the legal and policy framework for city-contracted residential waste collection services.

September 9, 2024: The contract with Waste Connections will be discussed with ACES. The recommendation will be included with staff’s presentation of this memo.

Proposed Actions / Recommendations

If Council desires to amend the Broomfield Municipal Code to allow the City to contract with a licensed hauler to provide residential waste collection services, the appropriate motion is:

That Ordinance No. 2242 be approved on second reading.

If Council desires to approve an agreement with Waste Connections of Colorado, Inc. to implement Broomfield’s City-contracted residential waste collection service program as contemplated with Ordinance No. 2242 that is effective if/when Council, the appropriate motion is:

That Resolution No. 2024-120 be adopted.

Alternatives

Ordinance No. 2422

Do not approve Ordinance No. 2242, delaying the consideration of contracted residential waste services at this time; or make changes to the Broomfield Municipal Code as directed by City Council. If Ordinance No. 2242 is not approved, that will discontinue exploration of city-contracted residential waste collection services pending further direction from Council and Resolution No. 2024-120 will not be considered.

Resolution No. 2024-120

Do not approve Resolution No. 2024-120 and deny the contract as presented. This will discontinue exploration of city-contracted residential waste collection services with volume-based pricing until further

direction is provided by Council; or Table the consideration of Resolution No. 2024-120 and direct staff to renegotiate with Waste Connections of Colorado. Denial of the contract will delay the effective date of Ordinance No. 2242. The ordinance only becomes effective if/when a contract is approved by Council which must happen no later than July 31, 2025.

Additional Detail on the Waste Connections Contract, Resolution No. 2024-120

Carts

Trash and recycling carts will be owned, deployed and maintained by Waste Connections of Colorado. They will collect resident-owned carts and their cart vendor will make commercially reasonable efforts to reuse or recycle the carts. Trash cart size can be changed once during program rollout at no cost; after that, trash carts can be downsized for free at any time, and requests to increase trash cart size will be subject to a \$25 change fee.

Customer service requirements

Waste Connections of Colorado has a reputation for excellent customer service, and staff has appreciated their collaborative approach during contract negotiations. Their original proposal and the proposed contract include provisions to facilitate customer service including designating a single point of contact for CCOB staff and having leadership on the ground during rollout; coordinating routes with CCOB; local customer service call center staffed by Colorado residents, including Spanish-speaking staff; monthly, quarterly and annual reporting on missed collections and customer complaints and resolution; and penalties (“liquidated damages”) for service violations such as failure to resolve verified missed collections in a timely way, failure to resolve spills or leakage, and failure to respond to customer calls or email inquiries within one business day.

Composting

Broomfield will not be contracting for composting services at this time. The contract includes a provision to negotiate curbside composting services at any time during the contract. Options for Broomfield residents who wish to compost currently include DIY composting at home, contracting a compost hauler to collect organic materials, or taking organic materials to a compost drop-off through compost clubs. Staff is evaluating opportunities and costs associated with options for residents who want to divert organic material from their trash.

Billing

Waste Connections of Colorado will bill residents directly. Residents who choose to opt out will be billed the minimum service fee by the City and County of Broomfield on a monthly basis. Note: the minimum service fee is designed to maximize participation in the program, not to generate revenue. See Financial Considerations for revenue estimates.

Colorado's Producer Responsibility Program

Colorado's Producer Responsibility Program to fund access to recycling, is expected to begin in 2026. Details of the state's program are still being finalized. The proposed contract includes a provision ensuring that any reimbursement the hauler receives through the state program will directly reduce the fees paid by residents on a dollar-for-dollar basis.

Waste Diversion Impact

The proposed contract with Waste Connections of Colorado is expected to increase Broomfield's waste diversion rate by at least 2% to 4%, based on 2021 data, with an additional 1-2% increase anticipated due to outreach and education. These estimated impacts were calculated using a Broomfield-specific model developed by Abbe and Associates, a leading zero-waste consulting firm contracted by cities nationwide.

Bold type indicates new material to be added to the Broomfield Municipal Code
~~Strikethrough type~~ indicates deletions from the Broomfield Municipal Code

Ordinance No. 2242

An ordinance amending certain sections of Title 8 Chapter 4 of the Broomfield Municipal Code to implement City contracted waste collection services

Section 1. Recitals

Whereas, the City and County of Broomfield (“Broomfield”) is committed to protecting the environment;

Whereas, Broomfield desires to encourage waste reduction to further the City’s waste diversion goals;

Whereas, the intent of this Ordinance is to: (1) reduce the volume of waste entering the waste stream and landfills, (2) encourage the recycling of certain discarded materials; (3) provide predictable collection service rates for residential community members, and (4) to protect the health, safety and welfare of the public.

Now, therefore, be it ordained by the City Council of the City and County of Broomfield, Colorado:

Section 2.

Chapter 8-04, Garbage, of the Broomfield Municipal Code is hereby amended to read as follows:

8-04-010 - Definitions.

For the purposes of this chapter, the following words shall have the following meanings:

(A) *Garbage* means and includes any and all rejected or waste household food, offal, swill, kitchen refuse, and every accumulation of refuse, animal, fish, fowl, fruit, or vegetable matter, liquid or otherwise.

(B) *Hauler* means person or company that collects, transports or disposes residential refuse, rubbish, garbage, recyclable materials, trash and other discarded materials for another that is not merely incidental to the provision of other services for the customer, for a fee or for no fee, that is licensed by the city.

(C) *Homeowners’ association* means any residential covenant-controlled community which includes a lawfully constituted and operational board or

other similar entity which is empowered to enforce the community's recorded covenants and which has the power to impose assessments for its services which, if unpaid, may be made a lien on the property.

~~(B)~~ (D) *Person* means and includes all natural persons, associations of natural persons, partnerships, firms, or corporations acting in their own behalf or in a fiduciary or representative capacity.

(E) *Recyclable Materials* means those materials, goods and items deemed as single-stream recyclables by the city and county manager in the city contracted residential waste collection services agreement.

(F) *Residential Refuse* means any form of discarded material, junk, garbage, rubbish, trash, foreign substance, or debris intended for landfill disposal and recyclable materials taken by the city contracted residential refuse collection services hauler.

(G) *Residential refuse collection services* means the collection and transportation of residential refuse by the city contracted residential refuse collection services hauler from sources not otherwise exempt as provided in B.M.C. 8-04-026(C).

~~(C)~~ (H) *Rubbish* means and includes debris of all kinds, all accumulations of waste, refuse, and rejected animal, mineral, or vegetable matter, except garbage and manure.

~~(D)~~ (I) *Trash* means and includes ashes, waste paper, cans, bottles, broken glass and china, sawdust, leaves, weed and grass cuttings, shrubbery and tree trimmings, shavings, and packing material not including garbage, manure, or debris.

8-04-020 - Trash or garbage; deposit prohibited; receptacle required.

(A) It is unlawful to deposit or cause to be deposited in any street, public or private alley, vacant lot, or upon any premises within the city, any trash, rubbish, garbage, debris, manure, or any filthy, nauseous, or offensive matter of any kind.

(B) It is unlawful to deposit or cause to be deposited any **residential refuse**, trash, rubbish, garbage, or other material in a private, business, or commercial trash or garbage receptacle or container without the consent of the owner.

(C) The owner, occupant, tenant, or person in possession of each building or structure shall provide for a **residential refuse (as applicable)**, trash, rubbish, or garbage container or receptacle, and shall cause all trash, rubbish, **residential refuse (as applicable)** and garbage to be deposited and contained in such container or receptacle.

8-04-025 - City residential refuse collection services.

- A.** The city's contracted residential refuse collection service hauler shall furnish residential refuse collection services as provided in this section and pursuant to the terms of the city's agreement with the licensed hauler to all residents within the city except those sources specifically excluded pursuant to B.M.C. 8-04-026. Single-stream recycling containers, for those persons subject to the city's contracted residential refuse collection services program, shall be provided by the city contracted hauler. Such containers shall be used only for collection of materials deemed recyclable materials.
- B.** Residents using the city's contracted residential collection services hauler shall separate their recyclable materials from other discarded materials as directed by the city contracted hauler in the provided containers. Containers shall be placed in the street in front of the residence or alley adjacent to each residence on a schedule established by the city and communicated by the city contracted hauler.
- C.** Bulk refuse material not collected as part of the city's collection services, as designated by the city, shall be removed by arrangement with the city's residential refuse collection services hauler, another city licensed hauler, or the resident in accordance with B.M.C. 8-04-027. Neither the city, nor its contractors or licensed haulers shall have any obligation to collect or transport any refuse not in a proper container or any containers not properly placed for collection.

8-04-026 - Premises excluded from residential refuse collection services.

Except as otherwise provided in this chapter, the city shall not provide residential refuse collection services to the following sources:

- A.** All commercial or industrial establishments;
- B.** Multi-unit residences containing eight (8) or more units; and
- C.** Residents within homeowners' associations that provide curbside trash, garbage, debris, discarded material and recyclable materials collection services through a group account. Homeowners' associations must maintain an active waste contract and proof of an active contract must be provided to the city if requested, including a list of addresses covered by the group account. If the homeowners' association terminates such waste collection services to its residents, the homeowners' association shall provide written notice of termination to the city within 30 days.

8-04-027 - Refuse, recycling and compostable materials hauling.

Nothing in this chapter shall prohibit any person from contracting for or hauling their own refuse, recyclable and compostable materials provided such refuse and materials are collected and disposed of in conformity with all applicable city rules and regulations.

8-04-028 - Residential refuse collection services fees.

A. City council shall enter into a contract for residential refuse collection services with a licensed hauler which agreement shall establish the fees to be imposed for such services. If a residential refuse collection services customer elects to not use the services provided by the city's contracted waste hauler and is not otherwise exempt, such customer shall pay to the city the minimum level of solid waste service which fee shall be set and shall increase as otherwise provided for by the city's residential refuse collection services contract. The fees may be combined into one fee and shall be imposed on all city residents except those excluded from this chapter pursuant to B.M.C. 8-4-026. The fees shall be billed either by the city contracted hauler directly or in conjunction with the charge for city water and sewer services of the minimum service fee for those parties opting out of the city contracted residential refuse hauler's services and not excluded pursuant to B.M.C. 8-4-026.

B. The fees for waste services and the charge for city utility services are hereby declared to be parts of one debt to the city insofar as the same relate to any one resident, and the refusal or failure to pay any part of such debt for any period of service shall be sufficient cause for the city to avail itself of any or all remedies as set forth and in accordance with the provisions of Chapter 13-12 of the Broomfield Municipal Code; except that water service shall not be disconnected for non-payment of the residential refuse collection minimum service fees.

8-04-030 - License; required; application.

(A) No person shall engage in the business of collecting trash, rubbish, or garbage within the city without first making application to the city clerk for a license. Each application shall contain the following information:

- (1) Name, address, and phone number;
- (2) Doing business as;
- ~~(3) Public Utility Commission permit number;~~
- ~~(4)~~ (3) Number and description (weight, model, type, capacity, etc.) of vehicles used;
- ~~(5)~~ (4) Number of employees;

~~(6)~~ (5) References and Experience;

~~(7)~~ (6) Site of disposal of trash and waste material; and

~~(8)~~ (7) Applicant shall submit rate schedule with application and shall advise the city of any change in rates within thirty days after making such changes.

~~(B) Before there are any negotiations for a garbage collection license, the applicant must first obtain authority from the public utilities commission to operate such business within the corporate limits of the city.~~

8-04-040 - License; fee.

Upon approval of a garbage collection application, the city clerk shall issue the license upon the payment of a fee in the sum of \$150.00 per year, ~~and \$1.00 per sticker. The clerk shall issue a receipt together with stickers to be placed on the vehicles in a clearly legible location. Stickers shall not be transferable.~~ The licensees operating under this chapter shall pay the tax separately to the city clerk on or before August 1st of each year. All licenses issued pursuant to this chapter shall expire on the thirty-first of July of each year succeeding issuance, unless sooner revoked by the city council.

Section 3.

This ordinance is only effective if city council approves a contracted residential waste collection agreement with a licensed hauler on or before July 31, 2025. The ordinance will only be published after the contracted residential waste collection agreement is approved by City Council. The effective date of the ordinance will be seven days after publication of final passage. If a contracted residential waste collection agreement with a licensed hauler is not approved on or before July 31, 2025, then this ordinance shall fail, will not be published in full, and will be of no force or effect.

Introduced and approved after first reading on August 13, 2024, and ordered published in full.

Introduced a second time and approved on September 10, 2024, and ordered published upon approval of a contracted residential waste collection agreement with a licensed hauler on or before July 31, 2025.

The City and County of Broomfield, Colorado

Mayor

Attest:

Office of the City and County Clerk

Approved as to form:

PWG

City and County Attorney

RESOLUTION NO. 2024-120

A resolution approving an Agreement with Waste Connections of Colorado, Inc. for Broomfield's City-Contracted Residential Waste Collection Services Program

Recitals.

Whereas, the City and County of Broomfield ("Broomfield") is committed to protecting the environment and desires to encourage waste reduction to further the City's waste diversion goals;

Whereas, City Council approved Ordinance No. 2242 on second reading September 10, 2024, with the condition that the ordinance would only be effective if City Council approves a contracted residential waste collection agreement with a licensed hauler on or before July 31, 2025; and

Whereas, City Council desires to approve an agreement with Waste Connections of Colorado, Inc. to implement Broomfield's City-contracted residential waste collection service program as contemplated with Ordinance 2242.

Now, therefore, be it ordained by the City Council of the City and County of Broomfield, Colorado:

Section 1.

The Agreement between Broomfield and Waste Connections of Colorado, Inc. for City-contracted residential waste collection service program is hereby approved.

Section 2.

The Mayor or Mayor Pro Tem is authorized to sign and the Office of the City and County Clerk to attest the Agreement in form approved by the City and County Attorney.

Section 3.

The City and County Clerk is directed to publish Ordinance 2242 by title as the condition of approval has been met with the approval of this Agreement and the adoption of this resolution.

Section 3.

This resolution is effective upon its approval by the City Council.

Approved on September 10, 2024.

The City and County of Broomfield, Colorado

Mayor

Attest:

Office of the City and County Clerk

Approved as to form:

KKH

City and County Attorney

AN AGREEMENT BY AND BETWEEN THE CITY AND COUNTY OF BROOMFIELD
AND WASTE CONNECTIONS OF COLORADO, INC. FOR CITY-CONTRACTED RESIDENTIAL WASTE
COLLECTION SERVICES

1. PARTIES. The parties to this Agreement for City-Contracted Residential Waste Collection Services (this “Agreement”) are the City and County of Broomfield, a Colorado municipal corporation and county, (the “City”) and Waste Connections of Colorado, Inc., a Delaware corporation (the “Contractor”), collectively, the “Parties,” or individually, a “Party.”

2. RECITALS. The Recitals to this Agreement are incorporated herein by this reference as though fully set forth within the body of this Agreement.
 - 2.1. The City is seeking a contractor to provide weekly trash collection with pricing based on the size of the cart and bundled single-stream recyclables collection to Broomfield single-family and small multi-family (7 or fewer units) residents as described in the competitive selection process by Request for Proposal #23-013 issued on or about November 1, 2023.

 - 2.2. The Contractor’s response to the above referenced RFP was determined to be of best value to the City for the procurement of the waste and recycling services requested. At this time, composting services will not be included in the services provided; however, the City may desire to add compost services at a later date upon mutual agreement of the Parties.

 - 2.3. All terms not specifically defined herein shall have the meaning as set forth in Exhibit A.

 - 2.4. The Parties therefore desire to enter into an Agreement for completion of the services further described herein.

3. TERMS AND CONDITIONS. In consideration of the mutual covenants and promises of the Parties contained herein, and other valuable consideration, the receipt and adequacy of which are hereby acknowledged, the Parties agree as follows:
 - 3.1. Term. The Term of this Agreement shall commence September 10, 2024 and extend and be effective through March 31, 2030. The Contractor acknowledges and agrees that residential waste collection services pursuant to this Agreement shall commence on or before April 30, 2025, but no earlier than March 15, 2025 (the “Services Commencement Date”), the additional contract time is to allow the Contractor time to procure equipment and hire the additional staff necessary to provide the services described herein.

- 3.2. Scope. The Contractor shall furnish the labor, equipment, materials and supervision necessary for or incidental to the complete and timely performance of everything described or reasonably implied from this Agreement and the Scope of Work attached hereto as Exhibit A and incorporated by this reference (the “Services”) in accordance with generally accepted practices and to the level of competency presently maintained by others in the field and in accordance with the City’s authority pursuant to C.R.S. §30-15-401. For purposes of clarity and in order to meet the City’s sustainability goals, the Contractor shall ensure that all collections at a particular address occur on the same regularly scheduled day of the week for Customers.
- 3.2.1. Residential Households. Any residential household may choose to negotiate with any other solid waste collection service provider licensed to do business in the City or may choose to remove their own waste in accordance with applicable laws and regulations subject to the payment of the Minimum Service Fee (or Opt-Out Fee) set forth in Exhibit A.
- 3.2.2. Homeowners Associations. The City adopted Ordinance No. 2242 which details requirements for residential waste collection services for single-family and small multi-family (7 or fewer units) residents. Homeowners associations are exempt from the requirements if they are providing trash and recycling collection services to their residents. Homeowners associations may elect to participate in the City’s residential waste collection services agreement, subject to all rates, requirements, terms and conditions of this Agreement, by notifying the Contractor of such intent no less than 60 calendar days prior to the expiration of the existing contract with its current vendor that they desire to be incorporated into this Agreement. For purposes of clarity, homeowners associations are also permitted to contract separately with the Contractor through a group account in accordance with the Broomfield Municipal Code and in such event shall not be subject to the terms of this Agreement as such homeowners association would be considered exempt.
- 3.2.3. Municipal Waste Hauling. For purposes of clarity, this Agreement is limited to residential waste collection services. The City previously entered into an Agreement for trash and recycling services at municipal facilities throughout the City. The Contractor is not asked to provide any emergency services or disaster recovery services for the City, this Agreement is limited to single-family and small multi-family (7 or fewer units) residential services and any homeowners associations that elect to opt-in to this Agreement.

- 3.2.4. Composting/Organics Collection Services Option. At this time, the City has elected not to include composting or organic collection services within the scope of work. In the future, the City may desire to add organics collection services to this Agreement, and in such event the City shall provide a right of first opportunity to the Contractor to provide such services to increase waste diversion at acceptable costs and the Parties shall negotiate in good faith to add such services to the Agreement. Upon mutual agreement of terms, the Parties shall execute an amendment to this Agreement reflecting the terms for the organics collection services. In the event the Parties are unable to come to an Agreement after good faith negotiations, the City expressly reserves the right to contract separately for organics collections services as well, nothing in this Agreement requires the City to use the Contractor for organics collection services.
- 3.3. City's Role. The Contractor shall provide all services as described in this Agreement with no direct support from City staff, except facilitating the payment of the Minimum Service Fee (or Opt-Out Fee) as more particularly described in Exhibit A. Although City staff may collaborate with the Contractor on certain initiatives such as customer education and communication, such support is solely at the City's discretion. Notwithstanding the foregoing, the City intends to monitor and evaluate the progress and performance of the Contractor to ensure the terms of this Agreement are being met in accordance with the City's evaluating criteria and standards. The Contractor shall fully cooperate with the City relating to such monitoring and evaluation.
- 3.4. Carts. The Contractor shall be responsible for management of all carts and shall retain ownership of the carts during the term of this Agreement. The Contractor shall supply the initial carts requested by the Customer at no additional cost to the Customer as more particularly described in Exhibit A, such costs shall be incorporated in the base pricing of the Contractor's Services. The Contractor shall use commercially reasonable efforts to recycle any carts received by the Contractor that are no longer usable for whatever reason, including carts received from residents during the initial transition to the Contractor's services.
- 3.5. Invoicing and Payment. The Contractor is required to provide a high level of customer service, timely and accurate billing on behalf of the City, and professionalism in the performance of Services under this Agreement. The Contractor shall invoice the residents directly for the costs and expenses relating to this Agreement in accordance with the amount or amounts shown in the Pricing Schedules attached as Exhibit B and incorporated by this reference on a monthly basis. Customers shall have thirty (30) days from receipt of

invoices to pay the Contractor. Any payments not received within thirty (30) days shall be deemed Late Payments as set forth in Section 3.5.4 below. The invoicing that is sent to residents by the Contractor shall be consistent with the terms of this Agreement and may contain the City and County of Broomfield logo. The form of invoice shall be reviewed and approved by the City prior to invoicing to residents.

- 3.5.1. *Minimum Service Fee.* The Contractor shall be responsible for communicating all Customers who opt-out of collection services and shall promptly provide such information to the City as provided in Exhibit A. The City will *only* be responsible for collecting the Minimum Service Fee (or Opt-Out Fee) payable by residents which shall be collected via those residents' utility bills as more particularly described in Exhibit A. The Minimum Service Fee (or Opt-Out Fee) shall be the then current rate for the small cart as set forth on Exhibit B. The Minimum Service Fee (or Opt-Out Fee) shall be collected and retained in whole by the City.
- 3.5.2. *Annual CPI Modification of Rates.* Beginning one year after the Services Commencement Date, the pricing for the Contractor's Service contained in Exhibit B, may be increased no more than once per calendar year by one hundred percent (100%) of the annual percentage change in the All Urban Consumer Price Index (CPI-U) for Denver/Aurora/Lakewood using the standard reference base for the CPI-U all items index, currently 1982 to 1984 plus any change in law as described below. Adjustments shall be based on the twelve (12) month period ending on June 30 of the previous year that the request for increase is made. For example, an adjustment to the Contractor's collection service rates effective January 1, 2024 will be based on the CPI for the twelve (12) month period ending June 30, 2023. If the CPI is no longer published, rates shall be adjusted in accordance with a comparable index as determined by the U.S. Department of Labor. In no event shall the fees set forth on Exhibit B be reduced due to adjustments in the CPI-U. The Contractor shall provide the City with at least 90 days prior written notice of a proposed rate increase and the City shall verify the rate increase is in accordance with this provision of the Agreement. Rate increases shall be automatic upon the City's concurrence of the rate calculations as set forth in this paragraph. The Contractor shall provide notification to all Customers of the rate increase at least 60 days prior to such increase, limited to once a calendar year as indicated above.
- 3.5.3. *Change in Law.* Beginning one year after the Services Commencement Date, the Contractor may increase the rates for Services as a result of

increases in costs incurred by Contractor due to either of the following: (a) changes in local, state, or federal rules, ordinances, laws, or regulations occurring after July 1, 2023, or (b) increases in taxes, fees or other governmental charges as a result of legislation or voter action occurring after July 1, 2023 (other than income or real property taxes) - as either change may specifically relate to waste disposal or collection. Addition of residential units or subdivisions shall not constitute "changes in law" justifying an increase in rate structure. The Contractor shall use commercially reasonable efforts to notify the City of any proposed increases promptly. Notice of proposed increases due to changes in law must be accompanied by adequate supporting documentation justifying the increase. The Contractor shall provide the City with prior written notice of a rate increase due to a change in laws and the City shall verify the rate increase is in accordance with this provision of the Agreement. Rate increases shall be automatic upon the City's concurrence of the new rates as set forth in this paragraph, and if and as applicable may be applied retroactively upon City's concurrence to the effective date of such change in law. The Contractor shall provide notification to all Customers of the rate increase prior to such increase.

3.5.4. *Late Payments.* If a Customer fails to pay an invoice, the Contractor shall follow its normal late payment procedures provided that late payment fees may not exceed the greater of \$5 or up to 10% of the applicable charges or as otherwise permitted by applicable law.

3.6. Grant Funding. The City may actively seek grant funding from various sources to offset the costs of the residential waste collection program described herein. In the event the City is successful in obtaining grant funding, the Contractor and the City will work cooperatively and negotiate in good faith to revise the terms of the Pricing Schedules set forth on Exhibit B to reduce the cost of Services based on the funding obtained. Upon approval of the rate adjustment, the Contractor shall provide notification to all Customers of the rate changes as set forth in Section 3.5.2 of the Scope of Work.

3.7. Producer Responsibility Program. On June 3rd, 2022, the Producer Responsibility Program for Statewide Recycling Act, House Bill 22-1355 was signed into law. The law sets up a Producer Responsibility program that requires companies that sell products in packaging, paper products to fund a statewide recycling system to recycle those materials. These companies will form an independent non-profit organization, called a Producer Responsibility Organization (PRO), to coordinate, fund, and manage this statewide recycling system. The State of Colorado is still working to finalize the details of the program and potential benefits the City and Contractor may be able to access

under the program. The Parties will negotiate in good faith to revise the terms and scope of this Agreement if necessary to access funding from Producer Responsibility Organizations. The Contractor will assist the City in providing information needed for the Producer Responsibility Program including, but not limited to, providing the City with a net cost estimate for the provision of recycling services. The Contractor also acknowledges and agrees that any reimbursement obtained by the Contractor through the Producer Responsibility Program will offset, dollar for dollar, the fees paid by residents as set forth herein.

- 3.8. Waste Audit. The City, in its sole discretion, has the option to elect to complete one (1) waste audit during each calendar year of this Agreement, including contract extensions. If the City elects to conduct a waste audit, the Contractor shall support and provide assistance in order to complete the waste audit.

4. NOTICE AND AUTHORIZED REPRESENTATIVES. Any notice required or permitted by this Agreement shall be in writing and shall be sufficiently given for all purposes if sent by email to the authorized representative identified below. Such notice shall be deemed to have been given when the email was sent and received. The City may change its representative at any time by notice to the Contractor. The Contractor shall not replace the Contractor Representative unless: (a) the City requests a replacement, or (b) the Contractor terminates the employment of the Contractor Representative or the Contractor Representative changes roles within the company and the Contractor provides a satisfactory substitute. The City must approve a substitute Contractor Representative, and, if no substitute is acceptable, the City may terminate this Agreement. The Parties each designate an authorized representative as follows:
 - 4.1. The City designates the Community Sustainability Manager as the authorized representative of the City under this Agreement. Email address is gmcDaniel@broomfield.org.
 - 4.2. The Contractor designates Jacqueline Satterwhite as the authorized representative of the Contractor under this Agreement. Email address is jacquelines@wcnx.org.

If the Contractor is alleging that the City is in breach of this Agreement or has violated any term of this Agreement, Legal Notice shall be made by making the notice above with a copy to citycountyattorney@broomfield.org.

5. INDEPENDENT CONTRACTOR. The Contractor is an independent contractor as provided in C.R.S. § 8-40-202(2). The Contractor is not entitled to workers' compensation benefits and the Contractor is obligated to pay federal and state income tax on monies earned pursuant to this Agreement.

6. WARRANTY. The Contractor represents and warrants that:
- 6.1. *Performance of Services*. It is fully qualified to perform the Services described herein and has the financial capacity, operational capacity and equipment to assume the duties and responsibilities necessary to effectively render the Services and will perform the services in a timely, accurate, and competent manner in accordance with the professional standards of the industry; provided that, this warranty shall not abrogate any independent duty of care owed by the Contractor to the County.
 - 6.2. *Good Standing*. If it is an entity, it is duly organized, validly existing, and in good standing under the laws of the State of Colorado and has all of the professional licenses and permits required to complete the Services as required by law.
 - 6.3. *Entity Performance*. The execution, delivery and performance of this Contract by the Contractor does not and will not: (1) require the consent of any undisclosed person or entity, (2) violate any legal requirement or (3) conflict with, or constitute a breach or violation of (a) its entity's organizational documents, if any, or (b) the terms or provisions of any other agreement, instrument or understanding by which the Contractor is bound or affected.
 - 6.4. *Accuracy of Information*. None of the representations or warranties in this Agreement, and none of the documents, statements, reports, certificates, or schedules furnished or to be furnished by the Contractor pursuant to this Agreement or in connection with the performance of the obligations contemplated under this Agreement, at any time contain or will contain untrue statements of a material fact or omissions of material facts.
 - 6.5. *Independent Examination*. In accepting these responsibilities, the Contractor represents and affirms that it has made its own examination of all conditions affecting the performance of this Agreement, now or in the future, and of the quantity, quality, and expense of labor, equipment, vehicles, facilities, properties, materials needed, and of applicable taxes, permits, and applicable laws. The Contractor represents and warrants that it is capable of providing the Services to and provision of carts to any future Customers within the City.
 - 6.6. The Contractor makes no representation regarding the ultimate recycling of Recyclable Materials by any third-party facilities.

7. TERMINATION. Notwithstanding the time periods contained herein, this Agreement shall terminate:
 - 7.1. If the City fails to appropriate funds pursuant to Section 15 of this Agreement at the time as such then-existing appropriations are to be depleted; or
 - 7.2. In the event of a termination by default in accordance with Section 12; or
 - 7.3. Terminated by the mutual agreement of the Parties.

Upon termination of this Agreement, the Contractor shall provide to the City a .CSV or other mutually agreed upon file type with Customer name, service address, billing address, phone number, Customer email, and cart sizes per service type. In addition, the Contractor shall coordinate with the City to remove all carts upon termination of this Agreement.

8. INDEMNIFICATION. The Contractor expressly agrees to indemnify, defend and hold harmless the City or any of its officers or employees, agents, or officials from any and all claims, damages, liability, or court awards, including costs and reasonable attorney's fees, that are or may be awarded as a result of any loss, injury, or damage sustained or claimed to have been sustained by anyone, including but not limited to, any person, firm, partnership, or corporation, in connection with or arising out of any (i) willful misconduct, (ii) negligent act or omission, (iii) any violation of law, or (iv) any breach of any obligation, representation or warranty, undertaken by Contractor or any of its employees or agents in performing work pursuant to this Agreement. In the event that any such suit or action is brought against the City, the City will give timely notice thereof to the other Party. The Contractor shall not be liable for any claims resulting solely from gross negligence or willful misconduct of the City.
9. INSURANCE. To assure the City that the Contractor is always capable of fulfilling specified indemnification obligations, the Contractor shall purchase and maintain insurance of the kind and in the amounts required by the City, from an insurer with an AM Best FSR rating of A- or higher as more particularly set forth on Exhibit C. Current proof of such insurance is attached at Exhibit C, incorporated by this reference. However, proof of insurance attached as Exhibit C shall not be deemed to limit or define obligations of Contractor as provided elsewhere in this Agreement, and Contractor should rely on its expertise to obtain additional insurance coverage needed for the City and Contractor in its performance hereunder.
10. APPROVAL OF SUBCONTRACTORS AND CONSULTANTS. The Contractor shall not employ any subcontractors or consultants without the prior written approval of the City Representative. Prior to commencing any work, each subcontractor or consultant shall provide the appropriate insurance as required for the Contractor under this Agreement. The Contractor shall be responsible for coordination of the work and the acts and omissions of its agents, employees, subcontractors, consultants and suppliers, and shall bind each to the terms of this Agreement so far as are applicable. This

Agreement is voidable by the City if subcontracted by the Contractor without the express written consent of the City.

11. **PROTECTION OF PROPERTY.** All public and private property, including but not limited to, existing structures, utilities, services, roads, trees, shrubbery, walls and the like shall be protected against damage or interrupted services at all times by the Contractor while performing services pursuant to this Agreement. The Contractor shall be held responsible for repairing or replacing any and all property that is damaged by reason of the Contractor's work to the satisfaction of the City within three (3) weeks of the notification of such damage, which may be extended with written approval of the City. The Contractor shall not be liable for damage to pavement, curbing or other driving surfaces owned or under the control of the City, due to the weight of the Contractor's vehicles or the provision of collection Services under this Agreement unless due to the Contractor's negligence.

12. **DEFAULT.** The City reserves the right to make periodic, unscheduled inspection visits to collections sites to determine the Contractor's compliance with the terms of this Agreement.
 - 12.1. Acts of default hereunder shall include, but shall not be limited to, the following:
 - 12.1.1. The Contractor fails to commence the collection of rubbish, recycling, or fails to provide a substantial portion of the Services as provided herein for a period of more than five (5) days.
 - 12.1.2. The Contractor fails to obtain and maintain any permit required by any regulatory body that is required to enable and allow the Contractor to perform its duties under this Agreement.
 - 12.1.3. Any direct act or omission of the Contractor which creates a hazard to the health, safety or general welfare of the public in violation of law.
 - 12.1.4. The Contractor's continued or repeated failure, after receipt of notice from the City, to act or refrain from acting in a manner which subjects the Contractor to liquidated damages.
 - 12.1.5. Any failure or refusal to act in a manner authorized or directed by this Agreement which is committed or withheld by either party; and
 - 12.1.6. Any violation, either through action or inaction, of any provision of this Agreement.

 - 12.2. In the event of default, the non-defaulting Party shall provide the defaulting Party with ten (10) days prior written notice of its intent to exercise its rights hereunder, stating the reasons for such action and citing specifically the alleged default of the other Party. If the defaulting Party cures the default as alleged within the ten (10) day period, the non-breaching Party shall cease any

efforts to terminate this Agreement. However, if the breach is not within the reasonable control of the defaulting Party and cannot be substantially cured within ten (10) days, such cure period may be extended to an agreed period of time pursuant to a mutually agreed upon corrective action plan to cure the default so long as the remedial efforts continue in good faith. If, on the other hand, the defaulting Party fails to cure its default within the ten (10) day period, the non-breaching Party may exercise may elect to:

- 12.2.1. terminate this Agreement and seek damages;
- 12.2.2. treat the Agreement as continuing and require specific performance; or
- 12.2.3. avail themselves of any other remedy at law or equity.

13. **LIQUIDATED DAMAGES.**

13.1. *Amount.* Time is of the essence in completing the Work. Alternatively, and in lieu of actual damages for delay, in the event of delay in the completion of the Work as specified beyond the Completion Date, it would be difficult to determine the exact amount of the loss or damages suffered by the City due to delays in completion of the Work. However, the City has attempted to forecast a reasonable daily amount as compensation for the damages caused by the Contractor, based upon considerations which include, but are not limited to, public inconvenience and additional contract administration costs. Therefore, the Contractor will be liable to the City, as liquidated damages (and not as a penalty), as set forth in the chart below.

Action or Omission	Penalties/Liquidated Damages
Failure to deliver all Solid Waste, Recyclable Materials, and Bulky Items to a mutually agreed upon permitted landfill, a licensed materials recovery facility (MRF), or other approved facility. (Note: Delivery of Recyclable Materials to a landfill is not permitted and subject to liquidated damages.)	\$3,000 per load
Contractor utilizing a driver to provide Services that does not have a valid Class B CDL with air brakes endorsement and Colorado Drivers' License and/or is not current with DOT required training or other DOT requirements.	\$1,000 per day per driver
Commencement of residential collection prior to 7:00 am or continuance after 7:00 pm except as expressly permitted by the City in writing.	\$200 per verified incident (each truck on each route is a separate incident)

Failure to collect within a reasonable period of time, any Waste or Recyclable Materials that have been spilled by Contractor in the performance of the Services that the Contractor has knowledge of or has been notified of.	Twice the cost of cleanup to the City plus \$1,000 each incident to the extent the spill was caused by the Contractor's, or its employees, actions.
Failure to clean up and report to the City any leakage from Contractor vehicles or vehicle contents, including but not limited to trash, hydraulic leaks, oil, gas and similar leakages. (Note: The Contractor will still be liable for any separately assessed stormwater violations and penalties as allowed by law.)	\$1,000 each vehicle, each incident
Failure to collect verified missed collections reported by 4 pm within one (1) business day or those reported after 4 pm within two (2) business days (excludes late setouts & blocked carts which shall be collected within one (1) calendar week) (excludes severe weather delays, which shall be serviced in accordance with Exhibit A)	\$150 per Customer per day plus one month credit to the missed Customer if the same Customer is missed twice in the same month
Collection from residential premises on other than the day specified excluding severe weather, holiday schedule, Force Majeure as set forth in Section 28 below, or as otherwise approved by the City due to an unforeseen event or circumstance.	\$150 per route
Failure to provide required reports on a timely basis, and such failure is not cured within ten (10) days of written notice to Contractor of such failure.	\$1,000 per incident
Intentional or material misrepresentation by the Contractor in records or reporting.	\$1,500 per incident
Failure to respond to customer calls or email inquiries within one business day.	\$250 per incident
Failure to report any known noncompliance on behalf of the Contractor or Contractor's staff, including but not limited to spills, missed pickups, or any of the acts in this section.	\$250 per incident.
Failure to maintain clean and sanitary vehicles in accordance with <u>Exhibit A</u> , Section 4(l).	\$250 per vehicle, per occurrence
Failure to appropriately bill Customers according to the Agreement OR billing Customers for fees not approved by City and such failure is not promptly cured after Contractor's discovery of such failure, or receipt of notice of such failure OR failure to	\$100 per incorrect bill

provide text in Spanish on invoices with directions for accessing a Spanish speaking customer service representative.	
---	--

- 13.2. *Liquidated Damages Resolution Process.* The Contractor may dispute the occurrence or omission of the events listed in Section 13.1 above through a review process. The City and County Manager or their designee shall review all relevant documentation provided by the Contractor and the Customer or staff member who reported the act or omission of non-performance. All documents may be reviewed electronically. The City and County Manager or their designee shall issue a written findings and decision within 30 days of the Contractor’s request for a review. All reviews of liquidated damages shall occur within 30 days of the imposition of the damages.
14. MARKS. Subject to a Party’s express written approval, the other Party may use the Party’s name, logo, symbol, trademark or service mark (together “Marks”) in electronic, printed, stamped or inscribed materials to support and promote the relationship between the Parties during the term of this Agreement. Each Party’s right to use the Marks is royalty-free, non-exclusive, non-transferrable, and non-assignable.
15. FINANCIAL OBLIGATIONS OF THE CITY. All financial obligations of the City under this Agreement are subject to appropriation, budgeting, and availability of funds to discharge such obligations. Nothing in this Agreement shall be deemed to pledge the City’s credit or faith, directly or indirectly, to the Contractor. If funds for this Agreement are not appropriated and budgeted in any year subsequent to the fiscal year of execution of this Agreement as determined by the City, this Agreement may be terminated by the City upon written notice to the Contractor. The City’s fiscal year is currently the calendar year.
16. EXHIBITS. All exhibits referred to in this Agreement are by reference incorporated herein for all purposes.
17. CONFLICTS WITHIN THE CONTRACT DOCUMENTS. In the event that conflicts exist within the terms and conditions of this Agreement and the attached or referenced exhibits the former shall supersede.
18. INTEGRATION AND AMENDMENT. This Agreement represents the entire agreement between the Parties and there are no oral or collateral agreements or understandings. This Agreement may be amended only by an instrument in writing signed by the Parties. For purposes of clarity, the terms and conditions of any Contractor invoice, Contractor timesheet, or other form, including but not limited to indemnification, limitation of liability, or cancellation fees, shall be void and of no effect against the City notwithstanding any signatures on such form by a City employee. The Contractor’s

rights and obligations shall be solely governed by the terms and conditions of this Agreement. Upon the mutual agreement of the Contractor after good faith negotiations, the City and County Manager has the authority to amend this Agreement at any time during the term.

19. SEVERABILITY. If any provision of this Agreement as applied to either Party or to any circumstance shall be adjudged by a court to be void or unenforceable, the same shall in no way affect any other provision of this Agreement, the application of any such provision in any other circumstances, or the validity or enforceability of the Agreement as a whole.
20. ADDITIONAL DOCUMENTS OR ACTION. The parties agree to execute any additional documents or take any additional action that is necessary to carry out this Agreement.
21. MINOR CHANGES. The Parties executing this Agreement are authorized to make nonsubstantive corrections to this Agreement and attached exhibits, if any, as they consider necessary.
22. GOVERNMENTAL IMMUNITY. No term or condition of this Agreement shall be construed or interpreted as a waiver, express or implied, by the City of any of the notices, requirements, immunities, rights, benefits, protections, limitations of liability, and other provisions of the Colorado Governmental Immunity Act, C.R.S. § 24-10-101 et seq. and under any other applicable law.
23. RECORDS RETENTION. The Contractor shall maintain complete and accurate records of time spent and materials used for performance of the Work, Customer invoices, together with any invoices, time cards, or other supporting data reasonably requested. All records, data and documentation shall be retained by the Contractor for a period of not less than three (3) years after completion of the Work, and shall be subject to review, inspection and copying by the City upon reasonable notice. The City shall have the right to audit the records upon request after five (5) days' prior written notice to the Contractor during ordinary business hours. The audit will be conducted in a manner that is not disruptive to the Contractor's operations. The Contractor shall also maintain records of the tip fees paid by the Contractor for the Services, which shall be available to the City upon request.
24. OFFICIALS NOT TO BENEFIT. No elected or employed member of City government shall directly or indirectly be paid or receive any share or part of this Agreement or any benefit that may arise therefrom. The Contractor warrants that it has not retained any entity or person, other than a bona fide employee working solely for the Contractor, to solicit or secure this Agreement.

25. ASSIGNMENT. This Agreement shall not be assigned by either Party without the prior written consent of the other Party.
26. BINDING EFFECT. This Agreement shall inure to the benefit of and be binding upon the parties and their respective legal representatives, successors, heirs, and assigns, provided that nothing in this paragraph shall be construed to permit the assignment of this Agreement except as otherwise expressly authorized herein.
27. DAYS. If the day for any performance or event provided for herein is a Saturday, a Sunday, a day on which national banks are not open for the regular transactions of business, or a legal holiday pursuant to C.R.S. § 24-11-101(1), such day shall be extended until the next day on which such banks and state offices are open for the transaction of business.
28. DELAYS/FORCE MAJEURE. Any delays in or failure of performance by any Party of its obligations under this Agreement shall be excused if such delays or failure is beyond the reasonable control of the Party and is not the result of a fault or the negligence of the affected Party and such Party is unable to overcome such delay or failure through the exercise of due diligence. Such delays or failures may include, but are not limited to, a result of acts of God, fires, floods, earthquake, war, riot, and restraints or injunctions, not resulting from a Party's breach of any terms of this Agreement or other contractual commitment. Force majeure delays or failures do not include: economic or financial events that impact the Contractor's ability to access or use financial resources, labor disputes or strikes. To the extent that the performance is actually prevented, the Contractor must provide written notice to the City of such condition within three (3) days from the onset of such condition. Weather that causes suspensions or delays in Services, as referenced in the Severe Weather Protocol in Exhibit A, is not a force majeure act or event.
29. NO PRESUMPTION. The Parties to this Agreement and their attorneys have had a full opportunity to review and participate in the drafting of the final form of this Agreement. Accordingly, this Agreement shall be construed without regard to any presumption or other rule of construction against the Party causing the Agreement to be drafted.
30. GOOD FAITH OF PARTIES. In the performance of this Agreement or in considering any requested approval, acceptance, or extension of time, the Parties agree that each will act in good faith and will not act unreasonably, arbitrarily, capriciously, or unreasonably withhold, condition, or delay any approval, acceptance, or extension of time required or requested pursuant to this Agreement.
31. WAIVER OF BREACH. This Agreement or any of its provisions may not be waived except in writing by a Party's authorized representative. A waiver by any party to this

Agreement of the breach of any term or provision of this Agreement shall not operate or be construed as a waiver of any subsequent breach by either party.

32. GOVERNING LAW. This Agreement shall be governed by the laws of the State of Colorado. Venue for any legal action related to this Agreement shall lie in the District Court, Broomfield County, Colorado.
33. LAWS TO BE OBSERVED. The Contractor shall be cognizant of all federal and state laws and local ordinances and regulations that in any manner affect those engaged or employed in the work or which in any manner affect the conduct of the work, and of all such orders and decrees of bodies or tribunals having any jurisdiction or authority over the same, and shall at all times observe and comply with all such existing laws, ordinances, regulations and decrees, and shall protect and indemnify the City against any claim or liability arising from or based on the violations of any such law, ordinance, regulation, order or decree, whether by itself, its subcontractors, agents or employees. The Contractor shall procure all necessary approvals, licenses and permits at its own expense; provided, that, the Contractor will be able to receive no cost permits when such permits are issued by the City directly.
34. SURVIVAL OF OBLIGATIONS. The obligations contained in this Agreement that are not fully performed as of termination shall survive termination and shall continue to bind the Parties until fully performed.
35. DIGITAL ACCESSIBILITY STANDARDS. In 2021, the State of Colorado adopted HB21-1110 relating to the digital accessibility standards required to be implemented under the Colorado Anti-Discrimination Act (C.R.S. §24-85-101, et seq.) which makes it unlawful to discriminate against individuals with a disability. In order to comply with the law, the Contractor shall use commercially reasonable efforts to ensure that all digital deliverables and digital technology provided pursuant to the terms of this Agreement shall comply with at least the Web Content Accessibility Guidelines (WCAG) 2.1 Level AA, or such updated standard as the Colorado Governor's Office of Information Technology may adopt from time-to-time, and the Contractor shall work cooperatively with the City, at no additional cost, to meet any reasonable accommodation or modifications provisions unless otherwise exempt under the law.
36. EXECUTION; ELECTRONIC SIGNATURES. This Agreement may be executed in counterparts, each of which shall be deemed an original and all of which shall constitute but one and the same instrument. This Agreement shall not be binding upon any Party hereto unless and until the Parties have executed this Agreement. The Parties approve the use of electronic signatures for execution of this Agreement. All documents must be properly notarized, if applicable.

[The remainder of this page is intentionally left blank.]

This Agreement is executed by the Parties hereto in their respective names as of September 10, 2024.

THE CITY AND COUNTY OF BROOMFIELD,
a Colorado municipal corporation and county

Mayor
One DesCombes Drive
Broomfield, CO 80020

APPROVED AS TO FORM:

City and County Attorney's Office

CONTRACTOR:

WASTE CONNECTIONS OF COLORADO, INC.,
a Delaware corporation

By: 
Mark Ceresa, Division Vice President
Address: 5500 Franklin Street, Denver, CO 80216

EXHIBIT A SCOPE OF WORK

Background

The City and County of Broomfield is transitioning from an open market residential waste hauling system with licensing to a City-contracted residential services model. The City desires to meet the following goals with this Agreement including, but are not limited to:

- Increase diversion of Recyclable Materials and encourage reuse of Bulky Items as much as possible.
- Reduce the number of trucks on residential streets and achieve street maintenance savings as well as increase safety in residential neighborhoods.
- Reduce greenhouse gas emissions.
- Provide equitable pricing throughout the community.
- Provide cost-effective pricing for collection Services.
- Provide a high level of customer service.

Overview of Services

The Contractor shall provide weekly trash collection with pricing based on the size of the cart and bundled single-stream recyclables collection every-other-week. Eligible households that choose not to participate in the program will be charged a Minimum Service Fee (or an Opt-Out Fee) by the City.

Additional services included:

Bulky/Large Item Collection

1. DEFINITIONS.

- a. "Acceptable Waste" means Bulky Items, Recyclable Materials and Solid Waste but does not include Excluded Waste.
- b. "Bulky Item" means waste items that are too large or too voluminous to be placed in a closed residential waste container, which include, but are not limited to, furniture, appliances and small equipment, such as lawnmowers.
- c. Cart Terminology:
 - i. "Small Cart" shall mean a cart with a capacity of 30-39 gallons.
 - ii. "Medium Cart" shall mean a cart with a capacity of 60-69 gallons.
 - iii. "Large Cart" shall mean a cart with a capacity of 90-99 gallons.
- d. "Customer" means an owner or occupant of a Residential Unit that receives waste collection services from the Contractor under the terms of this Agreement.
- e. "Door-to-Door Service" means service in which the Contractor brings carts from the Customer's location to the curb or alley for servicing and returns the cart to the Customer's location.

- f. "Excluded Waste" means (i) Hazardous Waste, (ii) radioactive, volatile, corrosive, highly flammable, explosive, biomedical, infectious, biohazardous, or toxic waste as defined by applicable law, or (iii) any other waste prohibited from a disposal or processing facility.
- g. "Hazardous Waste" means waste defined as, or of a character or in a sufficient quantity to be defined as, a "Hazardous Waste" by the Resource Conservation and Recovery Act, as amended, or any state or local laws or regulations with respect thereto, or a "toxic substance" as defined in the Toxic Substance Control Act, as amended, or any regulations with respect thereto, or any reportable quantity of a "hazardous substance" as defined by the Comprehensive Environmental Response, Compensation and Liability Act of 1980, as amended, or any regulations with respect thereto. The term "Hazardous Waste" also includes any waste whose storage, treatment, incineration or disposal requires a special license or permit from any federal, state or local government entity, body or agency and any substance that, after the effective date of this Agreement, is determined to be hazardous or toxic by any judicial or governmental entity, body or agency having jurisdiction to make that determination.
- h. "Recyclable Materials" means the materials listed in Table 1 of Exhibit A and any other materials identified by the Contractor as Recyclable Materials, provided those materials have been separated from Solid Waste and can be recovered as useful materials and are properly prepared for the purpose of recycling.
- i. "Solid Waste" means all refuse, putrescible and non-putrescible waste, excluding electronics, discarded or abandoned vehicles or parts thereof, sewage, sludge, septic tank and cesspool pumpings or other sludge, discarded home or industrial appliances, materials used as fertilizers or for other productive purposes and Recyclable Materials which have been source separated for collection and does not include Excluded Waste.

2. CUSTOMERS.

- a. *Single-Family Residences and Multi-Family fewer than 7 units.* The Contractor shall provide the weekly curbside collection of Acceptable Waste and every-other-week for Recyclable Materials from single-family residences and multi-family residences containing seven or fewer units in accordance with C.R.S. §30-15-401 within the City and County of Broomfield as more particularly provided herein. Curbside means the property, within five (5) feet of the public street, alleyway, or private road adjacent to a Customer's residence (or on the sidewalk without completely obstructing the sidewalk, if there is no such property within five (5) feet of the public street or private road) without blocking driveways or on-street parking.
- b. *Homeowner Associations.* The City recognizes that a number of Customers within the City are within existing homeowner associations which already provide curbside trash and/or recycling services to Customers and often the homeowner association

is able to obtain better pricing due to the number of customers, as such those homeowner associations are specifically exempt from the ordinance regarding waste collection services. However, some homeowners associations may still desire to have the Contractor provide services to their community consistent with the terms of this Agreement. The Contractor will use commercially reasonable efforts to ensure a smooth transition of new homeowner association customers to the Contractor's Services and shall charge the then current rate City-contracted rate for all such Services to the homeowners association residents in accordance with Section 3.2.2 of this Agreement.

- c. *Non-Exclusive.* This Agreement shall not be considered an exclusive franchise for services to the residents of the City and any resident may choose to negotiate with any other trash removal service licensed to do business within the City or may choose to remove their own waste materials in accordance with applicable laws. If a resident decides not to use the service and is not part of a homeowner association that provides residents trash and curbside recycling, the resident will be billed the Minimum Service Fee (or Opt-Out Fee) as described below.
- d. *Minimum Service Fee (or Opt-Out Fee).* Customers may elect to opt-out of collection Services at any time by contacting the Contractor. While the Contractor shall not provide collection Services to the Customer opting-out, the Contractor shall still assist the City with billing the Customer the Minimum Service Fee (or Opt-Out) Fee as described on Exhibit B by providing the City with the list of residents who have elected to opt-out of receiving the residential waste hauling services as described in (i) below.
 - i. *Minimum Service Fee (or Opt-Out Fee).* The Contractor will assist the City with tracking those residents that opt-out of the Services under this Agreement and who are not within a homeowners association. The Contractor shall provide a list of residents, via a .CSV file or other format acceptable to the City on the 1st of the month, who have opted out of the Services and need to be charged a Minimum Service Fee (or an Opt-Out Fee). This file will be used to facilitate the City including such fee on the resident's utility bill. The Contractor .CSV file shall list of the name, address, and account number of all parties that should be charged a Minimum Service Fee (or an Opt-Out Fee), so that the City can properly charge the residents the Minimum Service Fee (or Opt-Out Fee). The file shall be delivered to breyes@broomfield.org no later than the 1st of each month so that the charges may be processed.
 - ii. *Opt-In Process.* At such time as a Customer desires to receive Collection Services again, or for the first time, the Contractor shall coordinate with the Customer to determine a mutually agreeable date to deliver carts and start Collection Services.
- e. *Accommodations.* The Contractor shall provide accommodations for Customers where no member of the household has the ability to place carts at the curb and in such case the Contractor shall provide such Customers with Door-to-Door Service

upon request for no additional charge. Customers may contact the Contractor directly and request the Door-to-Door service.

f. *Carts.*

- i. *Access.* Customers shall provide safe, unobstructed access to the carts on the scheduled collection day. The Contractor may charge an additional fee for any additional collection service required by the failure to provide access.
- ii. *Personal Containers.* Customers must use Contractor-provided carts for their collection Services. In the event the Customer uses a personal container for additional Services, the Contractor shall handle the Customer-owned container in such a way as to prevent undue damage. The Contractor shall be responsible for unnecessary or unreasonable damage to Customer-owned containers. The Contractor may refuse to collect materials left in personal containers at its discretion, with a communication to the resident of how to properly dispose of items.
- iii. *Cart Selection.* Customers shall be provided the opportunity to select the size of trash cart they desire for trash collection. Customers shall receive a large, 95 gallon, cart for recycling collection; provided, however, that the Contractor may provide a medium sized recycling cart upon a Customer's special request to accommodate special or extenuating circumstances. The initial selection of a trash cart size shall be initiated at least 60 days prior to commencement of services, and longer if deemed necessary by the Contractor and the City as part of the logistics and communication plan described below. On-going cart services shall be as indicated in Section 6 below.

- g. *Alleys.* Where alleys are the primary service option, the Contractor shall provide Collection Services in alleys. In areas where alley service is provided, the Contractor shall not be required to additionally provide curbside service except in such circumstances where homes are isolated from alleys. In the event that alley collection is not feasible due to unsafe conditions for the Contractor's vehicles, the Contractor will contact the residents affected and determine a mutually agreed upon alternate option for the collection services. The Contractor will report to the City any alternative collection arrangements and the residents affected.

3. OWNERSHIP OF WASTE. Contractor shall take ownership of Acceptable Waste when it is loaded into Contractor's vehicle. Ownership of and liability for any Excluded Waste shall remain with the generator and shall at no time pass to Contractor.

- a. *Right of Refusal for Excluded Waste.* If any Excluded Waste is discovered before it is collected by the Contractor, the Contractor may refuse to collect the entire pick-up that contains those Excluded Waste items. If the Contractor refuses to collect a pick-up due to contamination or Excluded Waste, the Contractor shall leave a notice with the Customer regarding the deficiency and reason for no pick-up. In the event such Excluded Waste items are present but not discovered

until after it has been collected by the Contractor, the Contractor may, in its sole discretion, remove, transport, and dispose of such items at a facility authorized to accept those items, in accordance with applicable law and charge the depositor or generator for all reasonable direct costs incurred due to the removal, remediation, handling, transportation, delivery and disposal of those items. Contaminants included with Recyclable Materials that exceeds thresholds for that collection stream set by the approved processing facility may not be collected, and may be left in the Customer's Cart with a prominently displayed written notification tag explaining the reason for rejection as more specifically detailed below.

- b. Recyclable Materials shall be collected and transported to a licensed materials recovery facility (MRF).

4. SCOPE OF WORK.

- a. The Contractor will provide weekly collection of trash and Solid Waste and every-other-week collection of Recyclable Materials on the same regularly scheduled day of the week for Customers.
- b. The Contractor will supply all residences served with:
 - i. Two-wheeled carts for collection of trash in Small Cart, Medium Cart, or Large Cart, depending upon the level of service selected by the Customer. The cost for trash collection shall be as set forth in Exhibit B.
 - ii. Two-wheeled carts for collection of recyclables in a Large Cart size. This cart will be labeled as containing recyclables. The Contractor shall have full responsibility for delivery, exchange, maintenance, removal, and replacement of recycling carts. Recyclables will be collected every other week. The cost for recyclables collections shall be as set forth in Exhibit B.
- c. If Solid Waste is set out inappropriately, improperly prepared, or contaminated with unacceptable materials, the Contractor shall notify the Customer of the reason(s) for rejecting the pickup of materials for collection. Failure to provide proper notification to Customers of the reason for rejecting materials for collection shall be considered a missed collection and/or subject to penalties due to lack of proper customer notification (See Section 13 of the Agreement).
 - i. Customers shall use the equipment (i.e carts) only for its proper and intended purpose. Customers shall not overload (by weight or volume), move, alter or install any devices on the equipment, and shall not manually or mechanically compact any materials inside the equipment, except inside compactor receiver boxes specially designed for such purpose, and shall not allow any third party to take any such actions. Customers may pay additional charges each time that a container is overloaded (by weight or volume) as set forth on Exhibit B.

- d. *Extra Waste.* The Contractor shall pick up additional bagged waste left outside of a regular trash cart for the fee listed on Exhibit B. The Customer shall bag the waste and place it alongside their cart on collection day. The Contractor will also pick up tree limbs and yard waste that is bundled for easy pick up for the same charge as if such waste was bagged. The Contractor shall document the extra waste that is picked up by capturing an image of the extra waste and shall include the additional applicable fees on the Customer’s next invoice.

- e. *Bulky/Large Item Collection.* Customers may submit a request for Bulky item pick up from the Contractor. This request can be made through the Contractor’s website, mobile application, customer service phone line or via electronic mail. Customers will be provided with a scheduled service day and instructions for setting out the large items. The Customer will be charged the rates set forth on Exhibit B for Bulky Items.

- f. *Recyclable Material Services.* The Recyclable Materials shall be collected every other week on the same day as solid waste collection, and shall be collected in one stream. The Contractor shall deliver materials to a licensed Materials Recovery Facility (MRF). If at any time during the term of the Agreement, the MRFs in the geographic area cease operation or processing of a specific commodity due to the material not being economically viable and the Contractor has no reasonable alternative for delivery of recyclable materials to a licensed MRF, the City and Contractor agree to negotiate, in good faith, a reasonable alternative agreed upon by both Parties. If a commodity listed under acceptable recyclable materials is not economically viable and will not be accepted by a licensed MRF, the City and Contractor agree to negotiate, in good faith, the removal of this commodity from the accepted recyclable materials list. In addition, the Contractor will communicate any changes to the Recyclable Materials to the Customers on a timely basis after such change, and such communication shall be reviewed and approved by the City prior to distribution.
 - i. Recyclable Materials shall not be landfilled unless the load is rejected from the recycling center due to contamination. If that occurs, the Contractor shall notify the City Representative within three (3) business day with details of the incident/cause of the contamination. The Contractor shall also include details and cause of the contamination incident in the regular report to the City Representative.

 - ii. The Contractor shall at a minimum collect the following Recyclable Materials:

Table 1 - Recyclable Materials	
Recyclable Cardboard	Plastic bottles, tubs, jugs and jars (#1,2 and 5)

Office paper (white and colored)	Aluminum cans, clean foil & pie plates
Magazines	Steel / tin cans & empty aerosol cans
Paperboard	Glass bottles and jars
Kraft paper	Aseptic containers

g. *Hours and Days of Operation.* The Contractor will limit regular collections between the hours of 7:00 am and 7:00 pm, Monday through Friday. Pick up may occur on Saturday or Sunday after previously designated and approved holidays. The Contractor will present its collection plan to the City for approval, and shall obtain the City Representatives approval prior to commencement of services. Any material modifications of the agreed upon collection plan shall be subject to prior approval by the City Representative.

h. *Service Routes.*

- i. *Initial Route Approval.* At least 60 days prior to the Services Commencement Date, the Contractor shall provide the City with a map indicating the day of the week collection Services will be provided to each Customer. The City shall review and approve the proposed map or work with the Contractor to revise the map, so that all Customers may be notified of their new collection date at least 30 days prior to the Services Commencement Date.
- ii. *Route Changes.* The Contractor may change the day of collection by giving notice at least 30 days prior to the effective date of the proposed change to and obtaining written approval from the City. Upon the City's approval, the Contractor shall provide affected Customers with at least 14 days written, telephone, and/or e-mail notice of pending changes of collection day. The Contractor shall obtain the prior written approval from the City of the notice prior to sending it to Customers.
- iii. *Disruptions Due to Construction.* The City may construct any improvement or permit any such construction in any public street in such manner as the City may direct, which may have the effect for a time of preventing the Contractor from traveling the accustomed route or routes for collection. The Contractor and the City shall develop a reasonable workaround to enable the Contractor to continue its collection Services. This shall be done at no extra expense to the City or the Customers.

i. *Holiday Schedule.* The Contractor will observe New Year's Day, Memorial Day, Independence Day, Labor Day, Thanksgiving Day and Christmas Day. If one of the

observed holidays falls on a scheduled collection day, collection will be on the next succeeding business day, which shall include Saturdays. The Contractor will supply an annual calendar, at no charge, to the participating Customers showing what trash and recycling materials are to be set out each week and the collection days during holiday weeks.

j. *Severe Weather Protocol.*

- i. On days when the City closes or declares a late start due to severe weather or other emergency, the Contractor may suspend or delay service without prior approval of the City; however, the Contractor may, in its sole and absolute discretion, continue with collection Services on a day when the City closes or declares a late start. The City will post such notification on the City's website by 5 am local time. In situations where the Contractor seeks to suspend or delay service, but the City has not closed its facilities or declared a delayed start, the Contractor must notify the City Representative in writing by 7 am local time of the basis for the service suspension for that day. The Contractor shall use commercially reasonable efforts to avoid any service suspension or delay.
- ii. The Contractor shall collect any missed collections due to suspended service within one business day of the resumption of service (as determined by Contractor) unless otherwise approved by the City Representative. The resumed service may cause a similar delay to other service days throughout that service week. (For example, if service is suspended on a Tuesday and resumes on Wednesday, the Tuesday Customers would be serviced on Wednesday and so on, including Friday collections taking place on Saturday.) The Contractor is authorized to perform collection Services after 7:00 pm during, or immediately after, disruptions due to inclement weather in order to finish the collection routes.
- iii. If severe weather requires a service suspension of two or more days in length, the Contractor may delay service of the necessary service days until the following regularly scheduled service day (for instance, if service must be suspended on Monday and Tuesday, Monday Customers' service may be delayed until the following service day so that Tuesday Customers would be serviced on Wednesday and so on, including Friday collections taking place on Saturday.)
- iv. If multi-day service suspensions take place over the course of multiple weeks, the Contractor shall adjust which day of service is delayed for one week. Any one service day shall not be delayed for more than one week (i.e. if storms take place on two Wednesdays in a row, Wednesday customers may have service delayed to the following week, but in the second week Thursday customers would be delayed so that no one set of

customers is without service for any longer than two weeks). The Contractor shall collect additional accumulated volumes of materials equal to what would have been collected on the missed collection day(s) from Customers at no extra charge.

k. *Missed Collections.* The failure of the Contractor to provide collection Services to a Customer that has been set out by the Customer in the proper manner on the appropriate day shall be considered a missed collection, and the Contractor shall collect the materials from the Customer within one business day of the Contractor's receipt of notification of the missed pick-up if notified prior to 4 pm. If the Contractor is notified of a missed pick-up by 9:00 am the following business day, the missed pick-up shall be collected that same day. The Contractor shall maintain an electronic record of all calls related to missed collections and the response provided by the Contractor. Such records shall be made available for inspection upon request by the City, and the information shall be included in monthly reports. (See Reporting requirements set forth in Section 9 of the Scope of Work below).

i. *Missed Collection due to Customer - Return Trips.* In the event the Customer fails to place their carts out for collection Services by 7 am on the day of collection and misses the collection, the Customer may contact the Contractor and request that the Contractor complete the collection Services at an alternate time subject to payment of the Return Trip Fee set forth on Exhibit B. The Contractor will use commercially reasonable efforts to remind the Customer of the extra charge for the additional pick up at the time of the request.

l. *Contractor's Personnel.*

- i. The Contractor's employees or subcontractors shall be courteous, refrain from loud or obscene language, exercise due care, perform their work without delay, minimize noise and avoid damage to public or private property. If on private property, the Contractor's personnel shall follow regular pedestrian walkways and paths, returning to the street after replacing empty containers. The Contractor's personnel shall not trespass, loiter, cross flower beds, hedges or property adjoining premises, or otherwise disturb any private property. While performing work under this Agreement, the Contractor's personnel shall wear an approved uniform with identifying badge or emblem visible to the average customer.
- ii. Each driver of a collection vehicle shall, at all times, carry a valid operator's license for the type of vehicle being driven.
- iii. If any of the Contractor's personnel performing collection services is, in the opinion of the City, incompetent, disorderly or otherwise unsatisfactory, the City shall document the incompetent, disorderly or unsatisfactory conduct in writing and transmit the documentation to the

Contractor with a request that such conduct be corrected. The Contractor shall investigate any written complaint from the City regarding any unsatisfactory performance by any of its workers. If the offending conduct is repeated, the City may require that the person be removed from all performance of services under the Agreement. Any such request shall be made in writing and the Contractor shall comply with the request within 3 business days.

m. *Vehicles.*

- i. Vehicles shall be maintained in a clean and sanitary manner, and shall be thoroughly washed at least once every two (2) weeks. All collection equipment shall have appropriate safety markings, including all highway lighting, flashing and warning lights, clearance lights, and warning flags, all in accordance with current statutes, rules, and regulations. Equipment shall be maintained in good condition at all times. Vehicles shall be repaired and/or have damaged areas repainted upon showing rust on the body or chassis or at the request of the City. All parts and systems of the collection vehicles shall operate properly and be maintained in a condition compliant with all federal, state, and local safety requirements and be in a condition satisfactory to the City. All vehicles shall be equipped with variable tone or proximity activated reverse movement back-up alarms.
- ii. The Contractor shall maintain collection vehicles to ensure that no liquid wastes (e.g., leachate) or oils (e.g., lubricating, hydraulic, or fuel) are discharged upon the Customer premises or the public streets and private roads. All collection and route supervisor vehicles used by the Contractor shall be equipped with a minimum 10 gallon capacity spill kit. Any equipment not meeting these standards shall not be used within the City until repairs are made. Clean-up of any discharge of liquid wastes or oils that occur from the Contractor's vehicles prior to them being removed from service shall be initiated by the Contractor within four (4) hours of being noticed/notified by route staff, Customers, or the City, and shall be remediated by the Contractor at its sole expense. Such clean-up or removal shall be documented and notice of such cleanup or removal shall be provided to the City in writing. The Contractor must notify the City within four (4) hours of when the Contractor should reasonably have known of the spill. Failure by the Contractor to notify, clean-up, or remove the discharge in a timely fashion to the satisfaction of the City shall be cause for performance fees, as described in Section 13 of the Agreement.

n. *Spillage.*

- i. All loads collected by the Contractor shall be completely contained in collection vehicles at all times, except when material is actually being

loaded. Hoppers on all collection vehicles shall be cleared frequently to prevent the occurrence of unnecessary blowing, leakage, or spillage.

- ii. Any leakage or spillage of materials upon the road surface that occurs during collection or any associated spillage or leakage entering the City's municipal storm system shall in accordance with Chapter 13-40 of the Broomfield Municipal Code be immediately controlled and cleaned up at the Contractor's sole expense and shall notify the Director of Public Health at (720) 887-2220 of the incident. The Contractor shall be responsible for all City's costs in the event that City staff or contractors are required for spill containment or cleaning due to the Contractor's action. The Contractor shall document the fluid leakage, including taking pictures before and after clean-up or removal, and shall provide the documentation to the City's Representative. Leakage or spillage not cleaned up or removed by the Contractor within the required time frame shall be cause for performance fees, as described in Section 13 of the Agreement. Should a leakage or spillage occur during collection, the Contractor shall notify the City's Representative. The Contractor expressly acknowledges it is solely responsible for any local, state, or federal violations, which may result from said leakage or spillage. Any leakage or spillage of materials that occurs during collection that is reported by Customers or the City shall be immediately cleaned up or removed by the Contractor at its sole expense. The Contractor shall document the reported leak or spillage, who reported the incident, and measures made to correct the incident and report this information via e-mail to the City's Representative within twenty-four (24) hours. Failure of the Contractor to comply shall be cause for performance fees, as described in Section 13 of the Agreement.

5. Suspending Customer Collection. The City and Contractor acknowledge that, in rare cases, some Customers may cause disruptions or conflicts that make continued service to that Customer unreasonable. Those disruptions or conflicts may include, but not be limited to, repeated damage to Contractor-provided Carts, repeated failure to timely set-out Carts followed by demands for return collection at no charge, repeated unsubstantiated claims of Contractor damage to a Customer's property, repeated contamination of Recyclables, and repeated failure to pay invoices when due. The Contractor shall make every reasonable effort to provide Services to such Customers. However, the Contractor may deny or discontinue service to such Customers no earlier than the Customer being 60 days past due for payments, or after the Contractor uses commercially reasonable efforts to educate the Customer on their failures with an opportunity for the Customer to cure their failures. Once Services are discontinued, the Contractor shall communicate the cancellation to the Customer. Once the Contractor discontinues service, the Contractor will remove all Customer Carts. The Customer can request to restart Services with the Contractor one (1) month after the discontinuation of Services, but can be subject to future discontinuation of service if problems persist. The Contractor shall notify the City of Customers whose service is

discontinued through reporting of the opt-out parties as set forth in Section 2(d) above and the monthly reporting in Section 9(c) below.

6. CARTS.

- a. The Contractor shall purchase, assemble, and deliver all Solid Waste and Recyclable Materials carts to the Customers. Cart ownership will be retained by the Contractor throughout the term of this Agreement. The cost of the carts shall be included in the monthly rates as stated in the Pricing Sheet, Exhibit B. The Customer's bill shall not include a separate itemized line-item price for carts.
- b. The carts shall be new or lightly used, wheeled units and shall meet the following specifications:
 - i. The cart lid shall be distinct for Solid Waste and Recyclable Materials carts.
 - ii. Cart sizes available must be consistent with service levels above.
 - iii. Carts must be compatible with industry standard collection equipment.
 - iv. Carts shall be manufactured with a minimum of ten percent (10%) residential post-consumer recycled plastic content based on the weight of the entire mass of the body, lid and wheels.
- c. *Damaged Carts.* Collection crews shall note damaged hinges, holes, poorly functioning wheels, and other similar repair needs for all Contractor-provided carts, and forward written or electronic repair notices that same day to the Contractor's service personnel. Repairs shall then be made no later than one (1) month after the notice is documented. Any cart that is damaged or missing on account of an accident, collection truck mechanical error, act of nature or the elements, fire, or theft or vandalism by a third party shall be replaced not later than three (3) business days after notice from the Customer or the City. In the event that a Cart is inadvertently lost into a collection vehicle during collection service due to mechanical or operator error, Customers shall be notified on the same day via an outbound call by customer service and a replacement cart shall be provided within three (3) business days of the loss. The Customer may also report damaged carts directly to the Contractor.
- d. *Replacement Carts.* Spare carts will be stored and managed by the Contractor. The Contractor must provide cart repair at no extra charge for labor (broken lids and wheels) and delivery of the replacement carts. Replacement carts and repair parts will be provided at the Contractor's expense and upon request by the Customer.
 - i. In the event that a Customer repeatedly (three (3) or more instances within a year) damages a Cart or requests more than one replacement cart during the term of the Agreement due to negligence or intentional misuse, the Contractor may charge the Customer a City-approved cart replacement fee.

- e. *Inventory.* Cart inventory must be maintained by the Contractor to satisfy Customer requests and any new residential developments and for the transition of HOA services from time to time.
- f. *Initial Start-Up Services.*
 - i. The Contractor shall affix information to carts at the time of delivery, which shall include the following:
 - 1. The information shall include but is not limited to guidelines and a service calendar.
 - 2. The information shall be designed collaboratively by the City and the Contractor with final written approval by the City Representative.
 - ii. The Contractor shall pay all printing and any other costs (such as cost for attaching to carts at delivery etc.) for the information.
 - iii. Upon receipt of a Customer complaint that Contractor delivered the incorrect size or type of cart, Contractor shall deliver correct carts and remove incorrect carts by the next scheduled service day for such waste stream.
- g. *On-Going Services - Exchange of Carts.* Customers may request to increase or decrease the size of their Trash Cart and/or Recycling Carts at any time by submitting a request to the Contractor. There will be no additional fees for requests to decrease the Cart size, and requests for an increase in Cart size shall be billed to the Customer at the fee set forth in Exhibit B (Note: Small carts are *not* available for Recycling Materials). Notwithstanding the foregoing, Customers will have a one-time right per household during the initial three (3) months of start of services to increase or decrease the size of their trash and/or recycling carts at no additional charge. Solid Waste cart exchanges will occur during the last week of the month to avoid prorations on the billing cycle. At the time the request is made, a customer service agent will advise the Customer what day the change will occur.
- h. *Cart Removal.* The Contractor shall remove all carts upon service cancellation within seven (7) days of the cancellation. The contents of removed carts shall be managed as if they were collected on a regular route. The disposal or recycling of materials accumulating in the Contractor's cart at the former Customer's location after the final Customer-paid collection shall be at the Contractor's, not Customer's cost.

7. COMMUNICATIONS.

- a. *Agreement Implementation.* The Contractor will use its expertise and knowledge to assist City staff in the transition to the Contractor's services being provided under this Agreement. The Contractor will develop a list of questions and issues and answers concerning the design, planning and implementation of the single-hauler trash and recycling collection program.

- b. *Program Commencement.* The Contractor will work with the City to provide service-oriented information to Customers and for developing and executing public education to encourage waste reduction and diversion. At least 3 months prior to the commencement of services within the City, the Contractor shall provide to the City Representative a comprehensive logistics and communications plan for the start of the collections Services, which plan shall be approved by the City, such approval not to be unreasonably withheld. The Contractor shall use commercially reasonable efforts to incorporate any feedback the City provides on improvements and enhancements to the logistics and communication plan.
 - i. Specifically, the plan shall include at least 30 days prior to the commencement of Service, the Contractor shall provide an 8-1/2" x 11" full-color leaflet to be distributed to each potential Customer. This insert will inform Customers of the specifics of the trash and recyclables collection program, including a collection schedule and calendar of Services as a visual guide, a listing of what materials can go into each waste stream, instructions on the proper handling of the collection carts, instructions on what Customers are to do with trash that does not fit into the collection carts, and other relevant information. At the same time, the Contractor shall provide a complete list of fees and services offered to each Customer. The contents of the insert shall be subject to approval by the City, and the Contractor will provide hardcopies for distribution.
 - c. *Additional Education.* In addition to providing the above educational information, the Contractor shall work with City staff to develop, provide and share educational information that will further improve the efficiency and waste diversion performance of the collection program. Such information shall include but not be limited to a dedicated City and County of Broomfield landing page website and integration of the Contractor's website as applicable. All educational communications to Customers must be approved by the City prior to publication.
 - d. *Public Informational Meetings.* At no cost to the City, the Contractor's management staff shall participate with City staff in all meetings necessary to introduce Contractor's services to participating residents. The Contractor will develop informational materials to hand out at these meetings, with the assistance of City staff.
- 8. CUSTOMER SERVICE STANDARDS.** The Contractor shall be responsible for providing all customer service functions including informing residents of current services, handling resident special service requests, and resolving customer complaints. The Contractor shall provide customer service through an employee dedicated to the City's Agreement ("Dedicated Employee") and located at an office within the Greater Denver Metro Area for all service calls between 8:00 a.m. through 5:00 p.m. local time, Monday through Friday. The Contractor may utilize additional locally based employees as needed to accommodate routine Dedicated Employee absences. For calls outside of regular business hours, the Contractor may utilize a national customer service line.

9. REPORTING REQUIREMENTS.

- a. *General Requirements.* All reports shall be submitted electronically in a format and with a level of detail that is acceptable to the City Representative. Each report shall include information since the last report (monthly / quarterly / annual). Monthly reports shall be submitted within 15 days of the end of the month. Quarterly and annual reports shall be submitted within 30 days of the end of the month/quarter/year as applicable. Information within each topic area shall be sorted by Customer address unless otherwise specified below. For the purpose of this section, service type shall mean Solid Waste, Recyclable Materials and Bulky Items. All reporting periods shall be based on a calendar year. The City reserves the right to request additional information mutually agreed upon by the City Representative and the Contractor.
- b. *Immediate Reporting.*
 - i. The Contractor shall notify the City Representative via email within twenty-four (24) hours in the following circumstances:
 1. The event of a serious accident involving injury or death.
 2. The Contractor shall notify the City Representative via email as well as immediately notifying the Director of Public Health at (720) 887-2220 in the event of any spill that enters a storm drain inlet or any significant spill.
 - ii. The Contractor shall send a report to the City Representative within three (3) business days if/when any of the following occur:
 1. Contaminated loads of Recyclable Materials that are rejected from processing facilities. The report shall include the date, service type, contamination type, situation that caused contamination, and any other relevant details.
- c. *Monthly Report.* The Contractor shall provide a monthly report on the following items:
 - i. *Materials Collected.* Scale-based weight data for Solid Waste, Recyclable Materials and Bulky Items collections, including facilities where they were delivered for reuse, recycling, composting, disposal or other management.
 1. The weight of City materials in any mixed loads that also includes non-City Solid Waste can be estimated using a methodology acceptable to the City.
 2. If materials were delivered to more than one (1) facility, include the scale-based weight data for each facility.
 3. Contaminated Loads. This report shall also include information on contaminated loads of Recyclable Materials rejected from a processing facility and delivered to landfill facilities including the date, service type, contamination type, situation that caused the contamination and any other relevant details.
 - ii. *Customer Complaints.* For purposes of this report, a complaint is any customer contact other than a service change or information request. The Contractor and the City Representative will develop a list of complaint types that are mutually agreeable, which may include missed

collection, unsafe driving, spills, operating outside permitted hours, or other customer service issues.

1. The Customer Complaint report shall include the date of complaint, service address, complaint type, resolution, and date resolved.
 - iii. *Missed Collection*. This report shall include the date of missed collection, date of resolution, service type missed, service address, and whether missed collection was due to Contractor or Customer (i.e. late set out, blocked cart etc.).
 - iv. *Accidents or Infractions*. Provide a summary of any incident report and investigation for any accident or infraction as well as any follow up actions taken to resolve the situation or prevent the situation in the future.
- d. *Quarterly Reports*. The Contractor shall provide a monthly report on the following items:
- i. *Customers*. This report shall contain the number of Customers receiving Services through the City contract and number of Customers opting out of the Services (i.e. charged the Minimum Service Fee or Opt-Out Fee).
 - ii. *Financials*. The report shall include the following:
 1. Any known performance violations and associated liquidated damages to be remitted to the City.
 2. Fees charged for the quarter sorted by fee type.
 3. Number of accounts over 90 days delinquent.
 - iii. *Customer Service*. This report shall include the following
 1. Number of customer communications including the date and type of customer service (complaint, service change, or information request) and summary of responses or resolutions.
 - iv. *Cart Activity*. This report shall include the type of cart, type of action (delivery, repair, replacement, removal, exchange), request date, completion date, and service address. If the Customer is changing cart size, include the initial and new cart size.
 - v. *New Opportunities*. The Contractor shall identify any new opportunities to decrease materials landfilled, increase reuse, recycling or composting of materials.
- e. *Annual Report*.
- i. *Customers*. Annual average of the number of Customers receiving Collection Services through the City contract and number of Customers opting out of the Services (i.e. charged the Minimum Service Fee or Opt-Out Fee).
 - ii. *Materials Collected*. Summary and monthly scale-based weight data for Solid Waste, Recyclable Materials and Bulky Items collections, including facilities where they were delivered for reuse, recycling, composting, disposal or other management for each month of the year.
 - iii. *Annual Summary*. The report shall include an annual summary of the following:

1. Missed collections by Contractor expressed as a raw number and as a percentage of the Customers receiving Services through the City contract.
 2. Missed collections due to Customer (late set-out, blocked cart etc.) expressed as a raw number and as a percentage of the Customers receiving Services through the City contract.
 3. Number of contaminated loads of Recyclable Materials rejected by processor with brief notes of the cause.
 4. Carts delivered, repaired, replaced, removed or exchanged, sorted by activity type as a number and as a percentage of carts serviced by Contractor's collection Services.
 5. Annual Financial summary including:
 - a. Amount of liquidated damages remitted to the City.
 - b. Amount of fees charged, sorted by fee type.
 - c. Service rates charged to Customers.
 6. Summary of Bulky Item material collection by item type.
- iv. *New Opportunities.* The Contractor shall identify any new opportunities to decrease materials landfilled, increase reuse, recycling or composting of materials.
- f. *Available Upon Request.*
- i. The Contractor shall provide to the City copies of Customer invoices and tipping fees paid by the Contractor upon request.
 - ii. The Contractor shall provide the net cost for recycling service delivery per household upon request.

**EXHIBIT B
PRICE SCHEDULE**

Weekly Trash and Every Other Week Recycling Services (All service levels include a large recycling cart)		
Trash Cart Size	Service Fee	Extra Cart Fees (Recycling)
32-gallon (Small Cart)	\$10.50	\$4.00 per month
64-gallon (Medium Cart)	\$19.43	\$4.00 per month
96-gallon (Large Cart)	\$29.93	\$4.00 per month
Extra Bags (Trash)	\$3.50 per bag	
Bulky Item Fee	\$25.00 per item	
Return Trip Fee	\$65.00 per trip	

The Minimum Service Fee (or Opt-Out Fee) equals the Small Cart Fee as adjusted from time-to-time.

Seniors (age 65 and over) and veterans will receive a 10% discount on the above referenced fees. Customers must request the discount to be eligible for the discount.

Cart Exchange Fees: Customers may request to increase or decrease the size of their Trash Cart and/or Recycling Carts at any time. There will be no additional fees for requests to decrease Cart sizes; Requests to increase Cart size will be subject to a \$25.00 change fee. (Note: Small carts will be available for Trash only.)

EXHIBIT C
INSURANCE REQUIREMENTS

**CITY and COUNTY of BROOMFIELD INSURANCE REQUIREMENTS - Including
Pollution Liability**

1. All insurers must be licensed or approved to do business within the State of Colorado.
2. Contractor/Vendor's insurance carriers should have an A.M. Best Company rating of at least A-VII.
3. Additional Insured - City and County of Broomfield, its officers, board members, agents, employees and volunteers acting within the scope of their duties for the City and County of Broomfield shall be named as Additional Insured on all Commercial General Liability, Pollution Liability, and Automobile Liability Insurance policies (construction contracts require Additional Insured coverage for completed operations).
4. Primacy of Coverage – Coverage required of Contractors and Subcontractors shall be primary and non-contributory to any insurance carried by the City and County of Broomfield
5. All subcontractors must meet the same insurance requirements for the Contract or Purchase Order unless Risk Management has approved a deviation.
6. Subrogation Waiver – All insurance policies required under this Contract maintained by Contractor or its Subcontractors shall waive all rights of recovery against City and County of Broomfield, its officers, board members, agents, employees and volunteers acting within the scope of their duties for the City and County of Broomfield.
7. Cancellation, Change in Coverage or Limits– The above insurance policies shall include provisions preventing cancellation, non-renewal, or reduction in coverage or limits of any insurance, without at least 30 days prior notice to Contractor/Vendor and Contractor/ Vendor shall forward such notice to within seven days of receipt of such notice.
8. Certificates – Contractor and all Subcontractors shall provide certificates showing insurance coverage required hereunder to the City and County of Broomfield within 5 days of:
 - a. the effective date of the Contract
 - b. the expiration date of any coverage
 - c. a request by the City and County of Broomfield
9. Separation of Insureds. All insurance policies shall include coverage for cross liability and contain a "Separation of Insureds" provision in the general liability policy.
10. City and County of Broomfield in no way warrants that the limits required herein are sufficient to protect the Contractor/Vendor from liabilities that may arise out of the performance of the work under this Contract by the Contractor, its agents, representative, employees or subcontractors. The Contractor is not relieved of any liability or other obligations assumed or pursuant to the Contract by reason of its failure to obtain or maintain insurance in sufficient amounts, duration or type.
11. All parties understand and agree that the City and County of Broomfield is relying on, and does not waive or intend to waive by any provision of this Contract, the monetary limitations, immunities, protections or any other rights provided by the Colorado Governmental Immunity Act.
12. The City and County of Broomfield reserves the right to negotiate additional specific insurance requirements at the time of the Contract.
13. The City and County of Broomfield and Contractor shall cooperate with each other in the collection of any insurance proceeds which may be payable in the event of any loss, including the execution and delivery of any proof of loss or other actions required to effect recovery.

Vendor/Contractor/Subcontractor shall obtain and maintain, at its own expense and for the duration of the contract including any warranty periods under which the Contract are satisfied, the following:

Insurance Requirements - Including Pollution Liability		
	COVERAGES AND LIMITS OF INSURANCE	Required
1.	<p>Commercial General Liability</p> <ul style="list-style-type: none"> Commercial General Liability insurance covering all operations by or on behalf of the contractor/vendor on an occurrence basis against claims for bodily injury, property damage (including loss of use), advertising liability, products and completed operations, and contractual liability. <p>Note: For contracts involving vendor/contractor contact with minors or at risk adults Sexual Abuse and Misconduct Coverage should be included in the coverage requirements.</p>	<p>Minimum Limits:</p> <ul style="list-style-type: none"> \$1,000,000 Each Occurrence \$2,000,000 General Aggregate (Per project aggregate for construction contracts) \$2,000,000 Products/Completed Operations Aggregate (for construction projects, this coverage should be maintained for a minimum of 3 years from the end of the project)
2.	<p>Automobile Liability</p> <ul style="list-style-type: none"> Automobile Liability Insurance covering any auto (including owned, hired and non-owned autos). 	<p>Minimum Limit:</p> <ul style="list-style-type: none"> \$1,000,000 each accident combined single limit. If hazardous materials are transported, an MCS 90 form shall be included on the policy.
3.	<p>Workers' Compensation</p> <ul style="list-style-type: none"> Workers' Compensation Insurance as required by State statute, covering all Vendors/Contractors employees acting within the course and scope of their employment. <p>Note: This requirement shall not apply when a contractor or subcontractor is exempt under the Colorado Workers' Compensation Act AND when such contractor or subcontractor provides an appropriate sole proprietor letter.</p>	<p>Employer's Liability with Minimum Limits:</p> <ul style="list-style-type: none"> \$100,000 Each Accident \$100,000 Each Employee by Disease \$500,000 Disease Aggregate
4.	<p>Environmental Liability Insurance</p> <ul style="list-style-type: none"> Contractor/Vendor will purchase an environmental liability policy covering bodily injury and property damage claims, including cleanup costs, as a result of pollution conditions arising from contractor/vendors operations and completed operations. 	<p>Minimum Limit:</p> <ul style="list-style-type: none"> \$1,000,000 Each Occurrence/Aggregate
<p>Additional Insured - The following shall be named an Additional Insured: The City and County of Broomfield, its officers, board members, agents, employees and volunteers acting within the scope of their duties for the City and County of Broomfield shall be named as Additional Insured on all Commercial General Liability, Pollution Liability, Umbrella Liability and Automobile Liability Insurance policies (construction contracts require Additional Insured coverage for completed operations). A Waiver of Subrogation is provided in favor of the Additional Insureds as respects to all policies.</p> <p>Certificate Holder is: City and County of Broomfield One DesCombes Drive Broomfield, CO 80020-2495 certificates@broomfield.org</p>		

Any deviations below the standards given above must be approved by the City and County of Broomfield's Risk Management office. Please direct any questions to RiskManagement@broomfield.org