



BRADLEY SCOTT WINDOWS LTD
SUPPLY & INSTALLATION OF UPVC WINDOWS, DOORS & CONSERVATORIES



MAINTENANCE HANDBOOK



BRADLEY SCOTT WINDOWS LTD
CHANGING THE FACE OF BRITAIN'S HOMES

INTRODUCTION

DEAR CUSTOMER

Congratulations on your new installation. We trust you will enjoy trouble-free use for many years to come.

As with any equipment, to obtain complete satisfaction it is advisable to carry out basic, regular maintenance.

This booklet contains useful tips and information to help you get the best from your investment.

As our policy is one of continuous improvement in products, methods and materials, changes in specification may be made from time-to-time without prior notice.





INDEX

MAINTENANCE	4
CONDENSATION	7
SECURITY	9
GLAZING	10
WINDOW STYLES	
- Open-out Window	12
- Tilt-Turn Window	14
- Fully Reversible Window	16
WINDOW HARDWARE	18
DOOR STYLES	
- Residential Door	20
- Tilt & Slide Door	22
- In-Line Sliding Patio Door	24
- Bi-fold Door	26
- Composite Door	27
RECOMMENDED PRODUCTS	28

MAINTENANCE

GLASS CLEANING

- Glass used in most double-glazed units is easily scratched and it is, therefore, recommended that hand jewellery is removed prior to cleaning.
- Any proprietary household cleaner may be used with a soft cloth and it is recommended that heavy external grime be initially removed with a solution of soap and water.
- Laminated glass, or glass containing Georgian bars, is cleaned in exactly the same manner.

SCRATCHED GLASS

- If scratches occur, most can be removed with jewellers' rouge, or an equivalent rubbing compound.

(See pages 10 & 11 for further information on glazing).

LEADED GLASS CLEANING

- In this type of double- glazing, lead strips are bonded to the outside and inside of the external pane of glass.
- Take care when cleaning leaded lights as excessive pressure might dislodge the lead from the glass surface.
- The use of warm soapy water and a soft cloth, moderately applied will prove an adequate cleaning method.

- During the initial stages of oxidation the lead can display many and varied colours. The colours that you will see are partly determined by the angle of view but can include white, copper and even green along with powdery deposits. This happens as the lead comes into contact with moisture and is basic lead carbonate.
- Customers should be aware that the changing appearance of the lead will settle down and that any action to remove the patina will result in the process starting over again. There is however, no way of saying how long oxidation will take. This basic lead carbonate can run off onto the glass under some circumstances and should be cleaned to avoid the likelihood of any staining.

Please note - Oxidation will always occur with all options of our Lead Strip. Some lead options are coated leads so there will be less oxidation but they may still oxidise around the edges.

Oxidation is a natural process which affects the appearance of lead, when exposed to the different environmental conditions. These conditions – rain, snow, condensation or any weather cycles will determine the degree of severity of the oxidation of the lead and the time scale over which it will occur. Oxidation is far more likely to occur during winter conditions, with the weather attacking the shiny new surface of the lead strip. The natural colour of lead is a matt grey, so it is normal and inevitable that discolouration will occur to the lead over time.

CONSERVATORY & PORCH ROOF CLEANING

(Avoid all solvent-based or abrasive cleaners).

- Roofing, rafters and PVC-U components fitted to these structures must be cleaned in a similar manner to PVC-U frames.
- It is important that all gutters and their respective outlets are regularly cleaned to help reduce moss/dirt build up. This build up will mean less water flows down the guttering and possibly cause them to overflow which can give the illusion that the gutter is leaking. Also check downpipes are not blocked up with debris e.g. leaves, moss etc.
- Wash roof panels with soap and water solution periodically to remove grime and atmospheric deposits.

Please note - self cleaning glass must be cleaned with water only as soap can destroy the protective layer of the self - cleaning glass

Do not walk on conservatory roofs.

WEATHERSEALS

- During cleaning and general maintenance ensure that any hand-inserted weatherseals fitted to your products do not become dislodged from their grooves. Should this occur, slide back into position immediately to avoid damage when the product is closed.
- If the weatherseals are broken or damaged and draughts are felt around the product, ensure prompt replacement by contacting your installer.

DRAINAGE

- Your double-glazed products are designed with an in-built drainage system, comprising slots within the thresholds that allow any water ingress to flow to the outside. To ensure an efficient system these slots must remain unblocked.
- Periodically, remove dirt, clear the drain slots (situated in the frame rebates) and check drainage operation by flushing through with water.

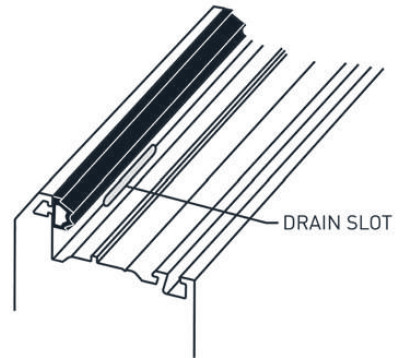

PVC-U FRAME CLEANING

(Avoid all solvent-based or abrasive cleaners).

- Wash frames with a soap and water solution periodically to remove any grime and atmospheric deposits.
- If required, clean with non-abrasive proprietary cleaner to remove any stubborn blemishes.
- Take care not to disturb sealants.

MAINTENANCE

LUBRICATION

To attain optimum performance, it is essential that all hardware is lubricated every 3 - 6 months depending on location and usage. Please note - doors or windows that are not regularly used still need to be maintained to make sure the mechanisms, moving parts etc. do not dry up and cause faults as lack on maintenance is not covered by the guarantee.

For lubrication of hardware etc, use light machine oil (e.g. 3-in-1 lubricant) for moving parts and petroleum jelly where indicated in the product specific lubrication instruction.

SILICONE SEAL

Please note that some discolouration of the Silicone seal is a natural occurrence and cannot be avoided.

CLEANING WINDOW AND DOOR HANDLES AND HINGES

Gently clean using a non-abrasive sponge or cloth with warm water and dry any excess water. You must remove any excess water so that they do not pit or rust.

LUBRICATING WINDOW AND DOOR HINGES

Lightly spray light machine oil (e.g. 3-in1 lubricant) on all moving parts every 3 months.

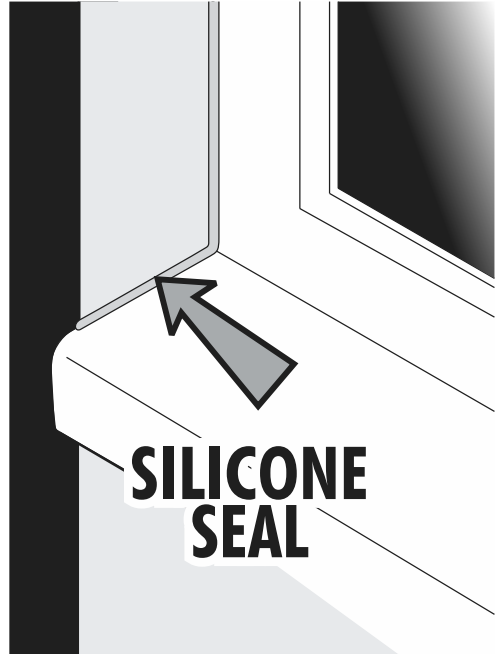

CONDENSATION

In general climatic conditions water vapour is continually present in the atmosphere. In the home this natural water content is increased by normal living activities that create steam, such as cooking, bathing, washing, boiling a kettle etc, plus the basic activity of breathing.

The water vapour remains undetectable while floating in warm air; but upon contact with cold surfaces, windows, mirrors, tiles etc, condensation occurs and the vapour turns to water droplets.

Fitting double-glazing does not necessarily solve underlying condensation problems.

Traditional house construction allowed the escape of this water vapour through natural ventilation - open flues of coal fires, air bricks and ill-fitting windows and doors.

The drive to conserve energy and reduce heating costs has led to the sealing of homes, resulting in trapped water vapour and increased problems of condensation.

The advent of more energy-efficient double-glazed units can, in certain circumstances, lead to condensation being evident on the OUTSIDE of the window.

VENTILATION

Provide natural ventilation whenever possible by:

- Opening a window
- Fitting a ventilator/extraction unit in the kitchen and bathroom.
- Fitting wall vents to provide air flow.

NB: Security should be borne in mind when leaving a window open

CONDENSATION

HEATING

- Maintain some permanent heat in the house during cold weather. Marginally increase the temperature in areas where condensation is a particular problem.
- If possible, fit radiators under windows to maintain the temperature of the inside pane of your double-glazing



CIRCULATION

Water vapour will easily drift on convection currents far from where originated.

- Keep internal doors to kitchen and bathroom areas closed and draught-sealed, where possible, to prevent the excessively moist air in these rooms being transferred to other areas of the house.
- Bedroom windows should have a night ventilation facility to provide air movement. Ideally, if bedroom doors are closed, a ventilation grille should be installed in or above the door also.
- To ensure air flow in the vicinity of windows, curtains should be a minimum of 150mm (6") away from the window, with suitable gaps, top and bottom, to allow circulation.



PREVENTION IS BETTER THAN CURE

Your double-glazed windows and doors have been specifically designed to include a variety of security features to protect your home and family against intrusion.

We recommend a number of sensible precautions which should be taken to gain full advantage of the security features available with your double glazing:

- Never leave a window open when your home is unattended.
- For added protection, lock all windows in the closed position and remove the keys.
- To provide adequate means of escape in the event of any emergency, we recommend that keys to all windows are located adjacent to the window, but out of external view.
- When leaving the house unattended or at night, ensure door handles are fully lifted and that the keys are turned to throw and lock all deadbolts/hookbolts for full security.
- Protect your door from natural thermal distortion. To stop this make sure the top and bottom locking points are engaged by pulling the handle up every time you shut the door.



GLAZING

All double-glazed units are susceptible to a degree of surface damage during the glass manufacturing process. Certain imperfections in the glass cannot be avoided, even in the most carefully controlled production environment.

Blemishes and imperfections are inherent in all double-glazing, and are acceptable within the highest standards of the industry.

We wish to draw your attention to the following extract from an industry accepted standard, relating to glass generally.

1. Transparent Glass, used in the manufacture of double-glazed units is identical to that used in traditional single-glazing and will therefore have a similar level of quality.
2. Both panes of the double-glazed unit shall be viewed from the room side, standing at a distance of two metres (6'6" approx) in natural daylight and not in direct sunlight. The area to be viewed is the normal vision area, with the exception of a 50mm (2") wide band around the perimeter of the unit.

NB: The appearance of modern low 'E' glass units, in certain sunlight, may present a "smokey hue". This appearance is perfectly normal. It is due to the metallic layer on the inner surface of the outer pane of glass.



3. Flat Transparent Glass shall be deemed acceptable if the following phenomena are neither obtrusive or bunched:
 - a. Totally enclosed seeds.
 - b. Bubbles or blisters.
 - c. Hairlines or blobs.
 - d. Fine scratches, not more than 25mm (1") long.
 - e. Minute embedded particles.

4. Obtrusiveness of blemishes shall be judged by looking through the glass and not at it, under normal lighting conditions as described in point 2.

Extracted from the Glass & Glazing Federation Standards.



GLASS DEFECTS

Your installer uses only the highest quality float glass available, whether laminated, toughened or annealed, which conforms to the requirements of Bs6262.

PATTERNED GLASS

This glass originates in very large sheets and due to spacing repetition, centralisation of any design in a specific window, cannot be guaranteed



WINDOW STYLES

OPEN-OUT WINDOW

This window may be opened outwards with its friction hinges holding it in a desired position. Locking is achieved by the mushroom cams and/or the shootbolt pins of the locking mechanism, fitted to the opening edge of the window, engaging into the keeps fitted to the outer frame.

These keeps usually have secondary slots incorporated within them, which when engaged provide a 'Night Vent' position. This allows the window to be slightly open, providing trickle ventilation.

- Accessible windows should not be left in the night vent position when the house is unoccupied.

OPERATING INSTRUCTIONS

- If fitted, turn key or depress button to unlock the locking handle. Handles with different key/button operating sequences may be fitted. Check with your installer for instructions.
- Rotate the handle through 90° to disengage locking mechanism and open by pushing outwards.

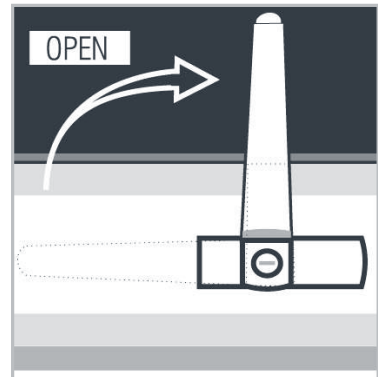
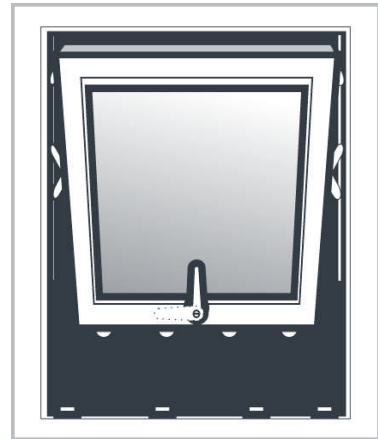
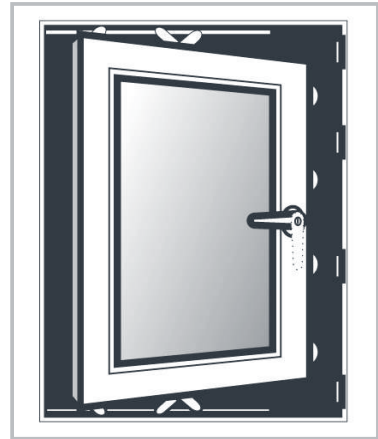

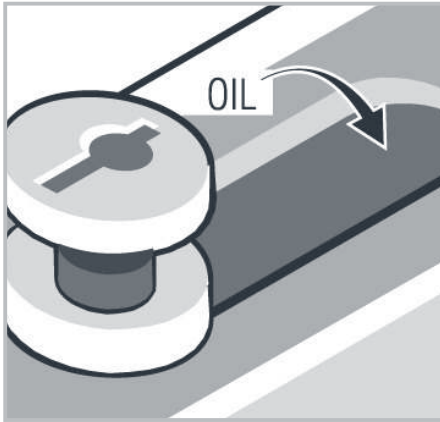

LUBRICATION - AS REQUIRED EVERY 3 MONTHS

Oil all pivot points (one drop per pivot is sufficient) and wipe away excess.

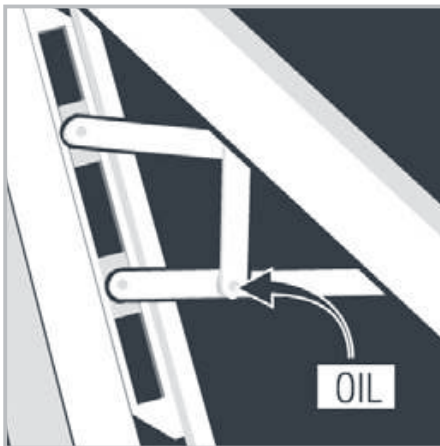

FRICTION HINGES

To attain optimum performance, the scissor mechanism of the friction hinges will require periodic lubrication. The pivots, sliding shoe and track should be kept free of dirt and debris.

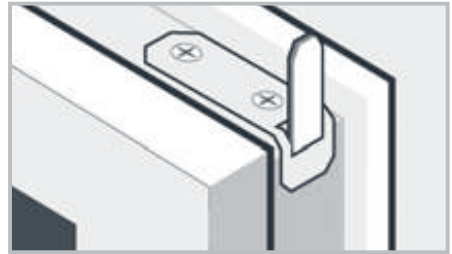

ESPAÑOLETTE LOCKING MECHANISM

Lubrication - As Required Keep sliding mechanism free of dirt and lubricate each slot with light machine oil.



KEEPS

Lubricate the slots of the keeps with petroleum jelly as required.

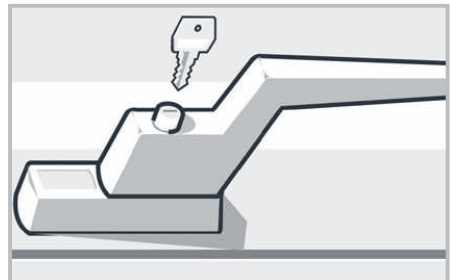

ESPAÑOLETTE HANDLES

Clean and lightly oil moving parts.

TILT-TURN WINDOW

These versatile inward opening windows are capable of two modes of operation.

- Tilt mode for ventilation.
- Turn mode for cleaning and emergency exits.

The term 'Tilt-Turn' refers to the sequence of operation of the window which is designed for safety, to initially select the 'Tilt' mode, followed by the 'Turn' mode.

Locking is achieved by a series of cams or espagnolettes, located on a sliding mechanism around the edge of the window. When shut and the handle 'closed' position is selected, the cams engage into keeps fitted around the outer frame, providing a secure locking system and excellent weathersealing.

Note: These windows can also be supplied in the Turn-Tilt (AKA Tilt and Turn) mode, whereby the sequence of operation is reversed. If you are in any doubt as to the sequence of operation please contact your installer.

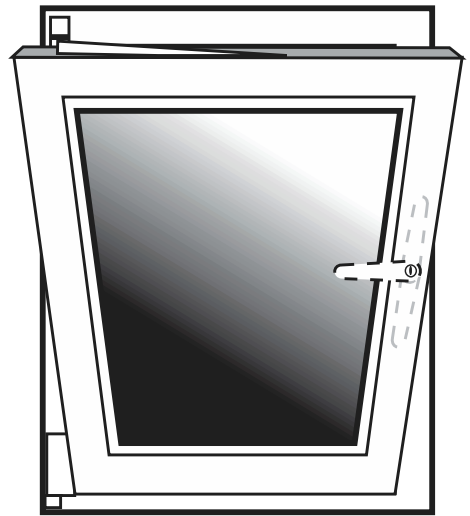

OPERATING INSTRUCTIONS

To operate the window, the handle is placed in one of three positions, 'Closed', 'Tilt' or 'Turn'.

The operation sequence commences with the window in the 'Closed' position (Handle vertically downwards).

Note: The window must always be fully shut before changing the handle position.

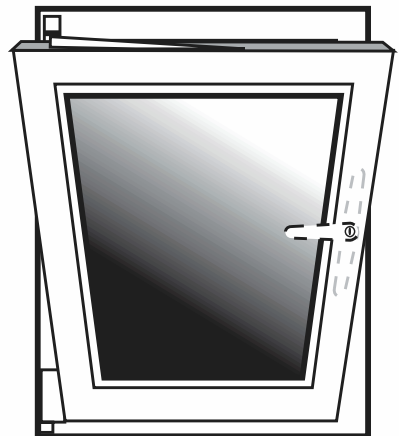
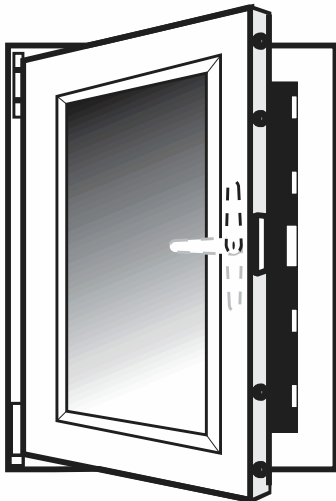

SWITCH BARRIER

The switch barrier projecting from the locking mechanism, adjacent to the handle, is a safety device which ensures that only one mode, 'Tilt' or 'Turn', can be selected at any one time by securing the handle into the selected mode, while the window is open. Avoid pressing the switch barrier as this action releases the handle and could allow it to be inadvertently rotated to the alternative mode, resulting in the window disengaging from its gear.

Always firmly push the opening leaf into the window frame before changing the handle position.

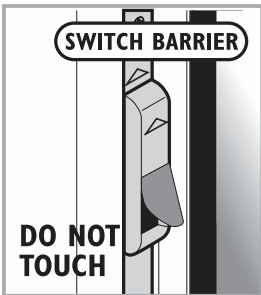
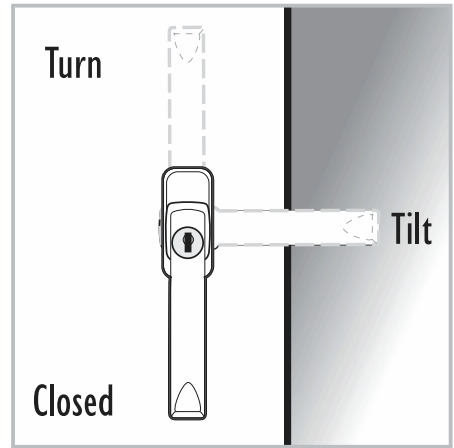

TILT-TURN LOCKING MECHANISM

Keep sliding mechanism free of dirt and lubricate each slot with light machine oil as required.

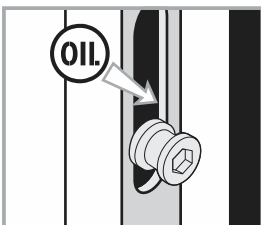

KEEPS

Lubricate the faces of the keeps with petroleum jelly as required.

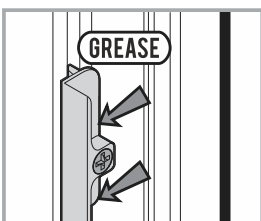

HANDLES

Clean and lightly oil moving parts.

- If fitted, turn key to unlock.
- To select 'Tilt', rotate the handle through 90° from vertically downwards to horizontal and pull the window inwards. The bottom remains hinged to the frame, while the top tilts inwards to allow ventilation.
- To select 'Turn' from the 'Tilt' mode, close the window and rotate the handle from its horizontal position to vertically upwards and pull the window inwards. The side remains hinged to the frame, while the window may be opened inwards to any desired position.
- To select 'Turn' from the 'Closed' position, rotate the handle through 180° from vertically downwards to vertically upwards and pull the window inwards.

WINDOW HARDWARE

RESTRICTOR

If fitted, the restrictor limits the opening of the window to control ventilation. The restrictor may be disengaged to allow the window to be fully opened. There are two main types of restrictor, the standard casement restrictor and the security restrictor.

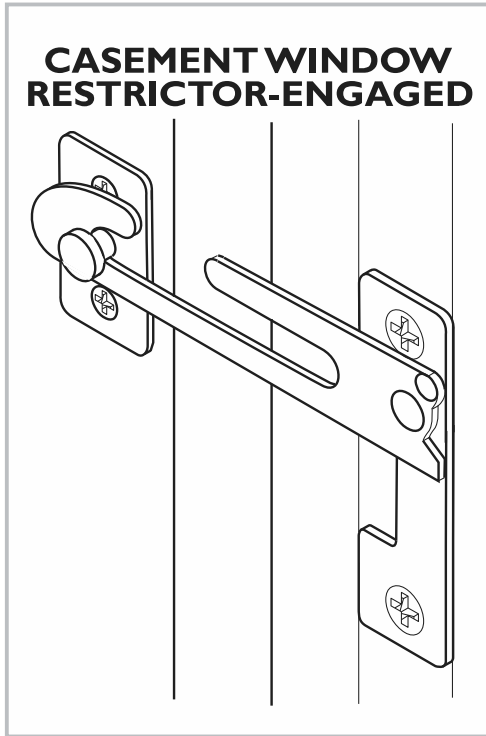

STANDARD CASEMENT RESTRICTOR OPERATING INSTRUCTIONS

TO OPEN - RESTRICTED

- Operate handle and open window. The restrictor arm will limit opening.

TO OPEN - FULLY

- Once opened to the restricted position, close the window slightly and manually release the restrictor by lining up the slot opening with the striker post. While holding the restrictor latch, open window fully.

TO CLOSE

- Close the window in the normal manner. The restrictor will automatically re-engage.

RESTRICTOR

SECURITY RESTRICTOR OPERATING INSTRUCTIONS

A special key is supplied to provide adjustment for the swinging arm and to enable the unit to be locked.

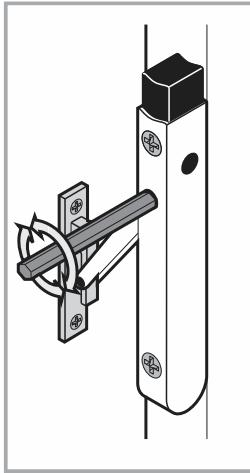

TO LOCK RESTRICTOR

- Insert special key at the back of the unit and rotate clockwise half a turn.

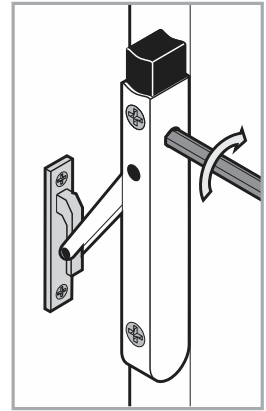

Note: To provide adequate means of escape in the event of any emergency, we recommend that keys to all windows are located adjacent to the window, but out of external view. engage.

TO OPEN - RESTRICTED

- Select required mode and open window. Restrictor arm will limit opening.

TO OPEN - FULLY

- Close window.
- While holding down control button, re-open window.
- Release button as soon as window has cleared frame.

TO CLOSE

- Close the window in the normal manner.
- The restrictor will automatically re-engage.

TO ADJUST SWINGING ARM

- Insert the key into socket at the side of the unit and rotate clockwise to tighten swinging arm or anti-clockwise to loosen.

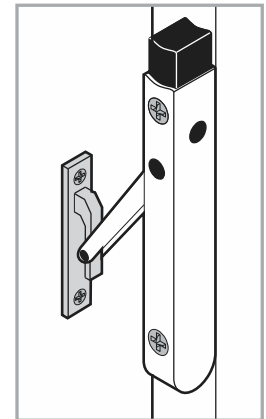

Note: that in the unlikely event that adjustment is needed, only a small movement (1/4 turn) will be required.

DOOR STYLES

PVC DOOR

High-security locking systems generally comprise multipoint deadbolts of various types, and a latch lock, which engaged in keeps fitted to the frame jamb.

The deadbolts are engaged by lifting the handle.

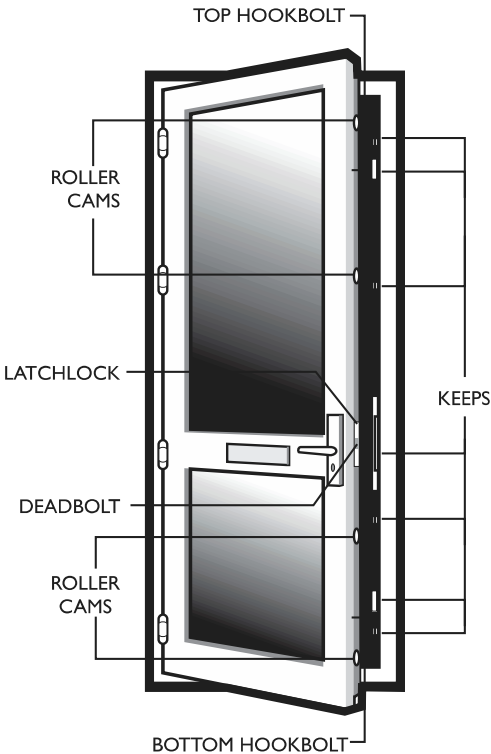

TO LOCK

1. Close the door - latchlock engages.
2. Fully lift the handle or pad to engage the top and bottom deadbolts/hookbolts/rollers.
3. Insert key and turn to engage centre deadbolt and fully lock.

If the key will not turn lift handle to maximum position and then turn key.

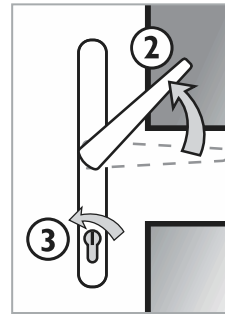

TO UNLOCK

1. Insert key and turn to unlock.
2. Press handle down to disengage top and bottom deadbolts/hookbolts/rollers.
3. With lever handle, door will open.

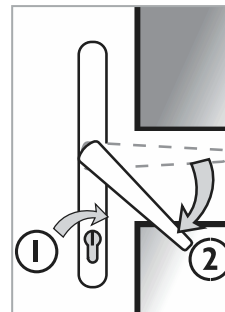

LUBRICATION – AS REQUIRED EVERY 3 MONTHS

LOCKING MECHANISM

- With the door open, lubricate the deadbolts/hookbolts/rollers and latchlock with light machine oil.

HINGES

- Clean and lightly oil hinge pins. If hinges are external (Open-out door) lubricate more regularly.

HANDLES

- Clean and lightly oil external moving parts.

LOCK CYLINDER

Lubricate with light oil (e.g. 3-in-1 lubricant). Keep key free of debris, dust etc. as this can impact how the key works in the cylinder.

DOUBLE DOORS

The main master door will operate the same as the locking mechanism explained above

SLAVE DOOR LOCKING

- A handle operated shootbolt lock operating in the same way as the master door (see above).

Lubrication - As required lightly oil external moving parts.

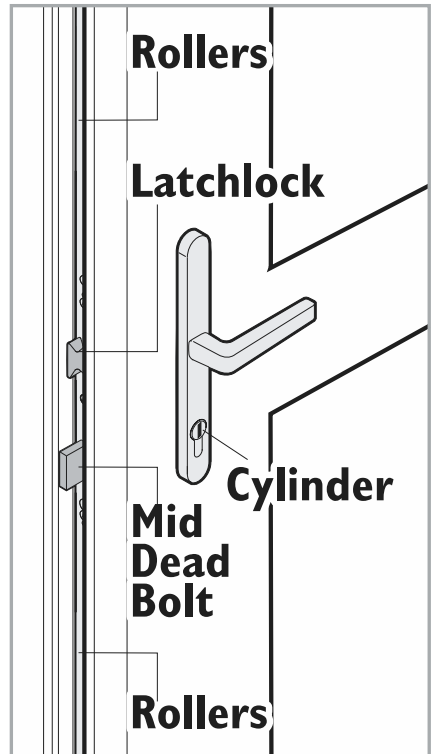

IN-LINE SLIDING PATIO DOOR

Patio doors are designed to be very low maintenance. The general service and maintenance tasks recommended are simple to carry out and do not require specialist skills, tools or equipment.

OPERATING INSTRUCTIONS

TO LOCK

- Slide door to fully closed position.
- Lift lever behind handle. (Bolts and Cams will engage to lock the door.)
- Turn key to deadlock locking mechanism.

TO UNLOCK

- Insert the key in cylinder and rotate to unlock the mechanism.
- Depress lever behind handle. (Bolts and cams will disengage).
- Slide door open.

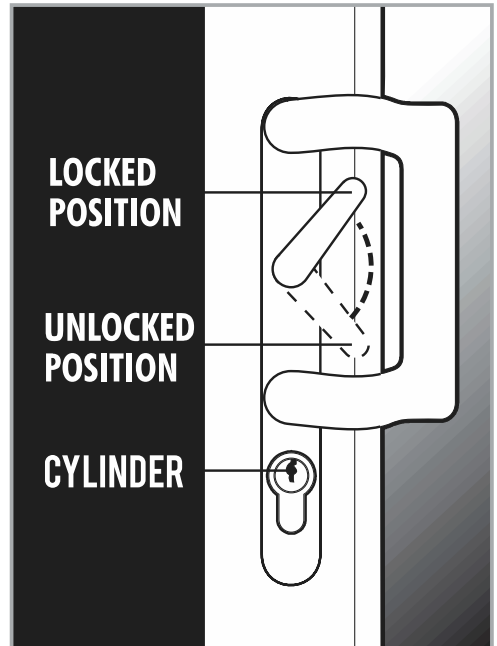

LUBRICATION – AS REQUIRED EVERY 3 MONTHS

Oil the locking cams of the mechanism.

LOCK CYLINDER

Lubricate with light oil (e.g. 3-in-1 lubricant). Keep key free of debris, dust etc. as this can impact how the key works in the cylinder.

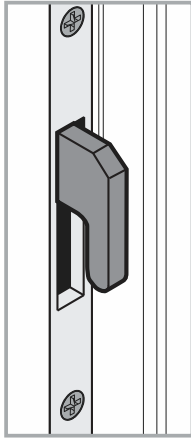

BOTTOM TRACK

Keep permanently free of dirt and obstruction. Ensure that drainage slots are clear of debris.

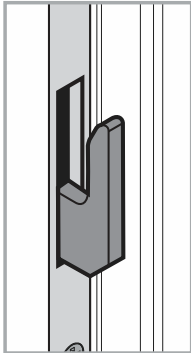

WEATHERSEALS

During cleaning ensure that any hand-inserted weatherseals fitted to your products do not become dislodged from their grooves. Should this occur, slide back into position immediately, to avoid damage when the door is closed. If the weatherseals are broken or damaged and draughts are felt around the product, ensure prompt replacement by contacting your installer.

Following the initial installation the weatherseal may require bedding in; causing a slight resistance when operating the door, the application of a silicone spray will aid the smooth operation of the door during this period.



OUTER FRAME AND SASH MAINTENANCE

Wash the frame with a soap and water solution, periodically as required, to remove any grime and atmospheric deposits. If required clean with a non-abrasive proprietary cleaner, suitable for plastics, using a soft cloth.

At least every 3 months, clean the internal and external surfaces of the frame and glass (or glazed panel(s)) to remove atmospheric grime; always use a soft cloth with mild liquid detergent solution, rinse with water and dry off. Periodically check that visible external drainage holes are free from any obstruction; if blocked, remove obstruction and flush through with water to ensure correct drainage.

BI-FOLD DOOR

Bi-fold doors are great space savers. They are designed to be very low maintenance. The general service and maintenance tasks recommended are simple to carry out and do not require specialist skills, tools or equipment.

LUBRICATION – AS REQUIRED EVERY 3 MONTHS

LOCK LUBRICATION

Clean and lightly grease external moving parts and frame keeps annually.

CYLINDER

Lubricate with light oil (e.g. 3-in-1 lubricant). Keep key free of debris, dust etc. as this can impact how the key works in the cylinder.

HINGE LUBRICATION

Clean and lightly oil hinge pins annually.

HARDWARE LUBRICATION

Clean and lightly grease all locking points and the inside top and bottom track. Please make sure the top and bottom tracks are cleared of any debris e.g. leaves etc. to make sure rollers/runners work correctly.

HANDLES AND HINGES

Gently clean using a non-abrasive sponge or cloth with warm water and dry any excess water. You must remove any excess water so that they do not pit or rust.



Composite door sets are designed to be very low-maintenance. The general service and maintenance tasks recommended are simple to carry out and do not require specialist skills, tools or equipment.

LEVER HANDLES

On a 3 - 6 month basis clean and remove dirt and debris from moving parts. Lightly oil all moving parts with a light machine oil (3-in-1 oil making sure this only touches the hardware and not the door itself as it can mark the door and cause discolouration).

NOTE: Do not use a metal polish. Do not use any abrasive cleaning products or a wire brush.

For stubborn stains, use a soft cloth with mild liquid detergent solution, rinse with water and dry off.

DOOR FURNITURE

Polish with a quality wax furniture polish. Apply polish to the cloth not the product. Use a good quality microfibre cloth.



CLEANING YOUR DOOR

Your composite door will stay in top condition with just one clean a month. Here's how to care for each part of your door.

Part of the Door	Cleaning	Finishing
Door Leaf	Keep the grime and grit away with warm soapy water (not washing up liquid) and wipe with a soft cloth.	
Door Frame	Wash with warm soapy water.	Stubborn stains demand a specialised PVC-U cleaner. Read the cleaner's guidelines carefully.
External Glass	Wash with warm soapy water with a soft cloth.	Finish with a proprietary glass cleaner.
Leaded Glass	Wash with warm soapy water.	Finish with a proprietary glass cleaner. (Oxidisation will naturally occur over time)
Hardware (handles, knockers, letterboxes etc.)	Take a clean cloth and warm water with a mild detergent, then simply wipe clean to a shine.	

CAUTION - DO NOT USE

- Washing up liquid or detergents (we recommend Stardrops)
- Abrasive cleaners or scouring pads
- High pressure or Steam cleaners
- Bleach, solvents (spirits and thinners) or adhesives
- Before cleaning your door remove all rings, bracelets and watches.

MAINTAINING YOUR DOOR

Bradley Scott composite doors are low maintenance - you'll find a little care every six months goes a long way.

Part of the Door	Cleaning	Finishing
Hinges	Keep them at their best by lubricating with a little light engineering oil, e.g. 3 in 1	
Cylinder Locks	Lubricate with light oil (e.g. 3-in-1 lubricant). Keep key free of debris, dust etc. as this can impact how the key works in the cylinder.	
Hardware (handles, knockers, letterboxes etc.)	Just add a touch of light engineering oil, e.g. 3 in 1 oil, on all moving parts.	Especially important if you live near the coast or by a building or industrial site.

IMPORTANT

Protect your door from natural thermal distortion. Make sure the top and bottom locking points are engaged by pulling the handle up every time you shut the door.



THERMAL MOVEMENT DEFINITION AND TOLERANCES

All composite slabs, as do UPVC and timber, experience thermal movement. The slab will recover to its flat plane, to a maximum bow of 3mm side to side and 5mm top to bottom, when the installation recommendations are applied (see below).

HORIZONTAL

Deflection of the slab inwards and outwards from side to side.



Maximum bow permitted is 3mm measured from the middle of the slab.

VERTICAL

Deflection of the slab inwards and outwards from top to bottom.

Maximum bow permitted is 5mm measured from the middle of the slab.

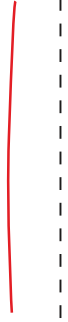

THERMAL MOVEMENT DEFINITION AND TOLERANCES

Slackening off the lock keeps will compensate for the movement of the slab within these tolerances. The hooks of the multipoint lock must be in compression with the inner edge of the pocket keep. If this does not happen the door may move to the inside of the property (towards the cold side) and give the impression the door is bowed. It is important to ensure the centre keep for the latch only allows the door to become flush with the inner face of the outer frame and not any tighter as this could also cause the door to appear bowed.

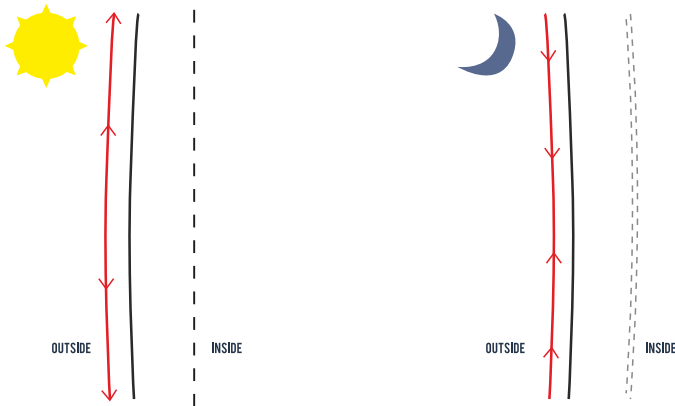

If the hooks on the multipoint lock are not thrown throughout the day and the centre keep setting is too tight, the top and bottom of the door will be in unsupported tension and will eventually stand proud of the inner face of the profile. This will make the hooks on the lock become stiff, as they cannot draw themselves into the hook keep.

If these points are not observed the warranties on the functionality and operation of the door could be affected. Condensation issues are typically building ventilation related, not product related.

IMPORTANT

Protect your door from natural thermal distortion. Make sure the top and bottom locking points are engaged by pulling the handle up every time you shut the door.

FOR FURTHER INFORMATION,
PLEASE CONTACT US.



BRADLEY SCOTT WINDOWS LTD

SUPPLY & INSTALLATION OF UPVC WINDOWS, DOORS & CONSERVATORIES

Alishia House • 440 Watling Street • Two Gates • Tamworth • Staffs • B77 1EJ

Opening Hours Mon - Friday 8am – 5pm • Sat 10am – 2pm • Sunday by appointment
We can arrange late openings by appointment

Tel 01827 288688 Fax 01827 282592

Email info@bradleyscottwindows.co.uk

www.bradleyscottwindows.co.uk

PRODUCTS WE RECOMMEND TO USE

- Soap - Stardrops
- Lubricant - 3 in 1 oil, Gt85

PRODUCTS NOT TO USE

These will cause damage and/ or stop your product from working correctly.

- Jet washes/ high pressure or steam cleaners
- Wet oils such as Wd40
- Washing up liquid or detergents
- Abrasive Cleaners or scouring pads
- Bleach or solvents



Using products not recommended on items we have supplied and installed may affect your guarantee. Failure to maintain your products in accordance to this handbook may also affect your guarantee. If you have any questions please contact us and talk to a member of our team.