



PERFORMANCE RANGE

- Flow rate up to **45 l/min** (2.7 m³/h)
- Head up to **105 m**

APPLICATION LIMITS

- Manometric suction lift up to **8 m**
- Liquid temperature between **-10 °C** and **+90 °C**
- Ambient temperature between **-10 °C** and **+50 °C**
- Max. working pressure **10 bar**
- Continuous service **S1**

CONSTRUCTION AND SAFETY STANDARDS

EN 60335-1
IEC 60335-1
CEI 61-150

EN 60034-1
IEC 60034-1
CEI 2-3



CERTIFICATIONS

Company with management system certified DNV
ISO 9001: QUALITY
ISO 14001: ENVIRONMENT

INSTALLATION AND USE

Suitable for use with clean water that does not contain abrasive particles and with liquids that are not chemically aggressive towards the materials from which the pump is made.

The design features of these particularly compact brass pumps provide a guarantee against rust and oxidation; they are therefore recommended for industrial applications such as cooling and air conditioning.

The pump should be installed in an enclosed environment or sheltered from inclement weather.

PATENTS - TRADE MARKS - MODELS

- Patent Pending n° 102015000012230 (PV60, PV65, PV81, PV70, PV90)
- Shaft: patent n. 0000275945 (PV55)

OPTIONS AVAILABLE ON REQUEST

- Special mechanical seal
- EN 10088-3 - 1.4401 (AISI 316) stainless steel pump shaft
- Other voltages
- IP X5 class protection for PV70-90

GUARANTEE

2 years subject to terms and conditions

CHARACTERISTIC CURVES AND PERFORMANCE DATA

60 Hz n= 3450 rpm HS= 0 m

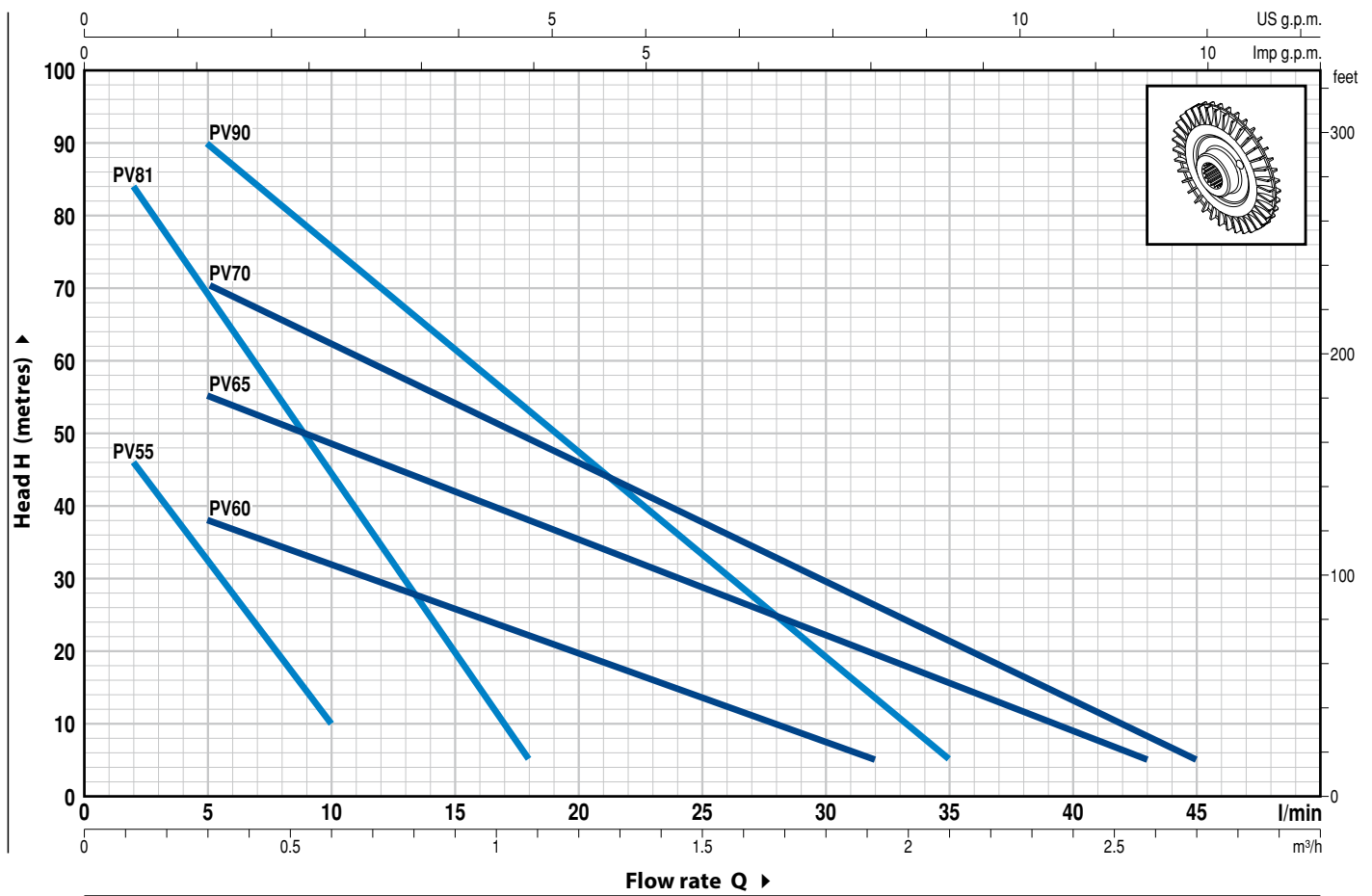

MODEL		POWER (P ₂)		Q	Flow rate									
Single-phase	Three-phase	kW	HP		m ³ /h	0	0.12	0.18	0.24	0.30	0.36	0.42	0.48	0.54
PV55	PV 55	0.18	0.25	H metres	0	2	3	4	5	6	7	8	9	10
				60 Hz	55	46	41.5	37	32.5	28	23.5	19	14.5	10
				50 Hz	42	35	31	27.5	24	20	16	12.5	9	5

➔ The PVm55 e PV55 pumps are designed to work at both 60 and 50 Hz

MODEL		POWER (P ₂)		Q	Flow rate													
Single-phase	Three-phase	kW	HP		m ³ /h	0	0.3	0.6	0.9	1.2	1.5	1.8	1.9	2.1	2.4	2.6	2.7	
PV60	PV 60	0.37	0.50	H metres	0	5	10	15	20	25	30	32	35	40	43	45		
				45	38	31.5	25.5	19.5	13.5	7.5	5							
				60	55	48.5	41.5	35	28.5	22	19.5	15.5	9	5				
				80	70	61.5	53.5	45.5	37.5	29	26	21.5	13	8	5			
				105	90	75.5	61.5	47.5	33	19	13.5	5						

MODEL		POWER (P ₂)		Q	Flow rate								
Single-phase	Three-phase	kW	HP		m ³ /h	0	0.12	0.24	0.30	0.36	0.48	0.60	0.84
PV81	PV 81	0.37	0.50	H metres	0	2	4	5	6	8	10	14	18
				92	84	74	69	64	54.5	44.5	25	5	

Q = Flow rate H = Total manometric head HS = Suction height

Tolerance of characteristic curves in compliance with EN ISO 9906 Grade 3B.

POS. COMPONENT CONSTRUCTION CHARACTERISTICS

1	PUMP BODY	Brass complete with threaded ports in compliance with ISO 228/1				
2	PUMP BODY BACK-PLATE	Brass				
3	MOTOR BRACKET	Aluminium				
4	IMPELLER	Brass with peripheral radial vanes				
5	MOTOR SHAFT	Stainless steel EN 10088-3 - 1.4104				
6	MECHANICAL SEAL	<i>Seal</i>	<i>Shaft</i>	<i>Materials</i>		
		<i>Model</i>	<i>Diameter</i>	<i>Stationary ring</i>	<i>Rotational ring</i>	<i>Elastomer</i>
		ST1-12E	Ø 12 mm	Silicon carbide	Graphite	EPDM
7	BEARINGS	<i>Pump</i>	<i>Model</i>			
		PV 55-60-65-81	6201 ZZ / 6201 ZZ			
		PV 70-90	6203 ZZ / 6203 ZZ			
8	CAPACITOR	<i>Pump</i>	<i>Capacitance</i>			
		<i>Single-phase</i>	<i>(220 V)</i>		<i>(110 V or 127 V)</i>	
		PVm 55	10 µF - 450 VL	25 µF - 250 VL		
		PVm 60	10 µF - 450 VL	25 µF - 250 VL		
		PVm 65	14 µF - 450 VL	25 µF - 250 VL		
		PVm 70	16 µF - 450 VL	60 µF - 300 VL		
		PVm 81	14 µF - 450 VL	25 µF - 250 VL		
		PVm 90	20 µF - 450 VL	60 µF - 300 VL		
9	ELECTRIC MOTOR	<p>PVm: single-phase 220 V - 60 Hz (50/60 Hz for PVm55) with thermal overload protector incorporated into the winding.</p> <p>PV: three-phase 220/380 V - 60 Hz or 220/440 V - 60 Hz (50/60 Hz for PV55).</p> <p>➔ The three-phase pumps are fitted with high performance motors in class IE2 (IEC 60034-30)</p> <ul style="list-style-type: none"> - Insulation: class F - Protection: IP X4 				

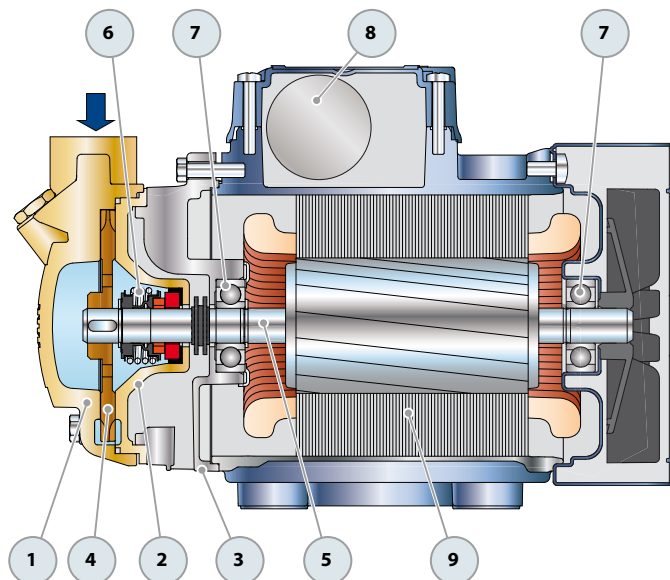

DIMENSIONS AND WEIGHT

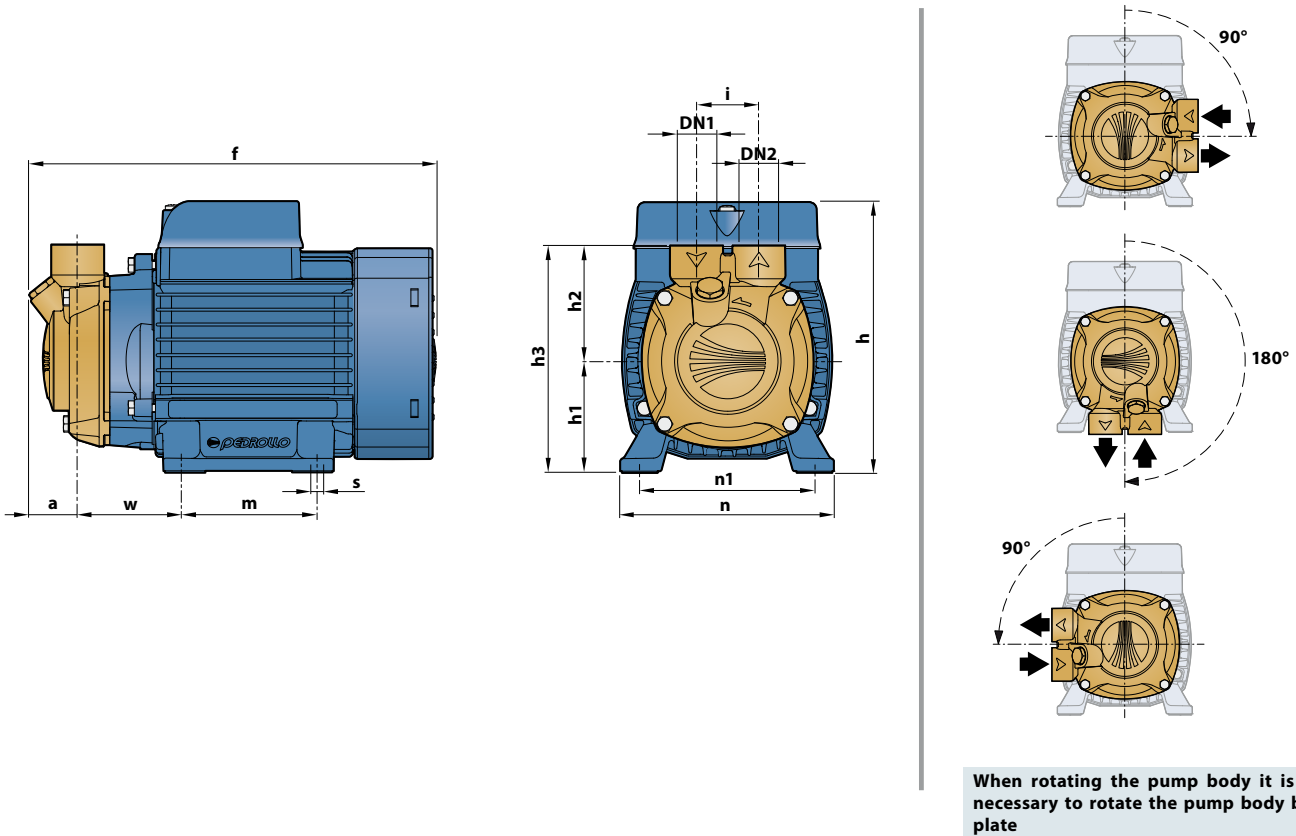

MODEL		PORTS		DIMENSIONS mm												kg	
Single-phase	Three-phase	DN1	DN2	a	f	h	h1	h2	h3	i	m	n	n1	w	s	1~	3~
PVm 55	PV 55	¼"	¼"	11	188	145	56	40	96	25	55	118	93-100	63	7	4.5	4.5
PVm 60	PV 60	½"	½"	24	221	152	63	62	125	35	80	120	100	60		5.5	5.5
PVm 81	PV 81			26	128			65	78					5.8		5.5	
PVm 65	PV 65	¾"	¾"	25	266	180 *	71	66	129	45	90	134	112	61		5.8	5.5
PVm 70	PV 70			24					137					71		9.0	9.0
PVm 90	PV 90			24					137					69		8.9	8.9

(*) h=199 mm for single phase versions at 110V or 127 V

ABSORPTION

MODEL	VOLTAGE		
	220 V	110 V	127 V
Single-phase	220 V	110 V	127 V
PVm 55 (50 Hz)	1.6 A	4.0 A	3.8 A
PVm 55 (60 Hz)	2.0 A	4.0 A	3.8 A
PVm 60	2.8 A	5.6 A	5.3 A
PVm 65	5.8 A	11.6 A	11.0 A
PVm 70	6.2 A	12.4 A	11.8 A
PVm 81	4.0 A	8.0 A	7.4 A
PVm 90	5.6 A	11.2 A	10.6 A

MODEL	VOLTAGE			
	220 V	380 V	220 V	440 V
Three-phase	220 V	380 V	220 V	440 V
PV 55 (50/60 Hz)	1.7 A	1.0 A	1.7	1.0
PV 60	2.0 A	1.2 A	2.1 A	1.2 A
PV 65	3.2 A	1.8 A	3.2 A	2.0 A
PV 70	4.2 A	2.4 A	4.2 A	2.4 A
PV 81	2.2 A	1.3 A	2.4 A	1.3 A
PV 90	4.2 A	2.4 A	4.0 A	2.3 A