

Submersible pumps in stainless steel



-  Filthy water
-  Domestic use
-  Civil use
-  Industrial use

PERFORMANCE RANGE

- Flow rate up to **750 l/min** (45 m³/h)
- Head up to **15 m**

APPLICATION LIMITS

- **5 m** maximum immersion depth
- Maximum liquid temperature **+40 °C**
- Passage of suspended solids up to **Ø 50 mm**
- Minimum immersion depth for continuous service: **300 mm**

CONSTRUCTION AND SAFETY STANDARDS

- **10 m** long power cable
- Float switch for single-phase versions

EN 60335-1
IEC 60335-1
CEI 61-150

EN 60034-1
IEC 60034-1
CEI 2-3



CERTIFICATIONS

Company with management system certified DNV
ISO 9001: QUALITY
ISO 14001: ENVIRONMENT AND SAFETY



INSTALLATION AND USE

BC-MF submersible pumps are recommended for draining **dirty and filthy water** in domestic, civil and industrial applications. They come equipped with a **DOUBLE-CHANNEL** impeller and are capable of pumping liquids containing short fibred suspended solids up to Ø 50 mm. They are ideal for pumping sewage, waste water, surface water and water mixed with mud in locations such as blocks of flats and detached house.

These pumps distinguish themselves for their reliability, which can be best appreciated under automatic operating conditions in fixed installations.

PATENTS - TRADE MARKS - MODELS

- Patent Pending n. BO2015A000116

OPTIONS AVAILABLE ON REQUEST

- Single-phase pumps without float switch
- Other voltages or 60 Hz frequency

CHARACTERISTIC CURVES AND PERFORMANCE DATA

50 Hz n= 2900 rpm

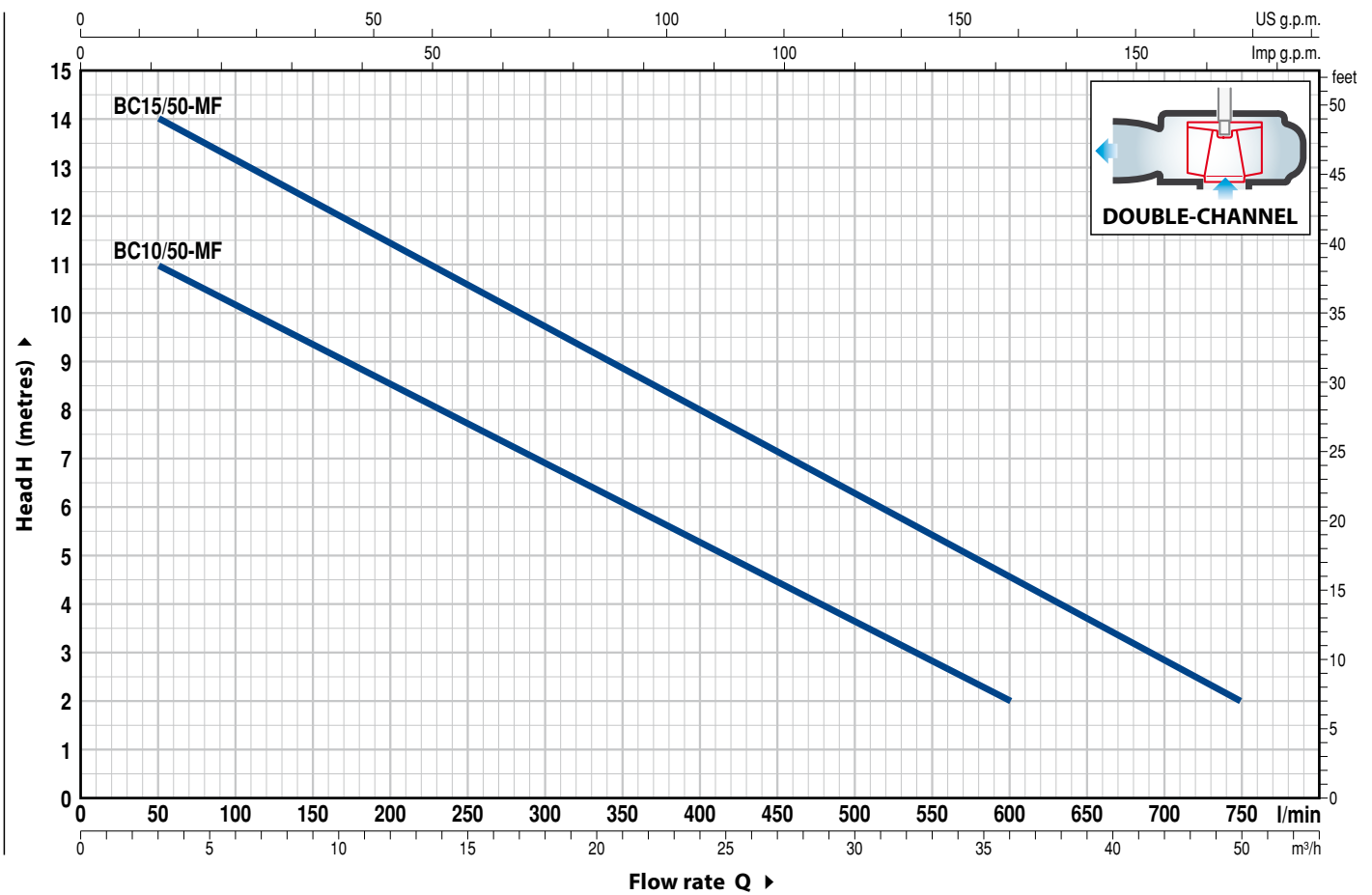

MODEL		POWER (P ₂)		Q	Flow rate													
Single-phase	Three-phase	kW	HP		m ³ /h	0	3	6	12	18	24	30	36	42	45			
				l/min	0	50	100	200	300	400	500	600	700	750				
BCm 10/50-MF	BC 10/50-MF	0.75	1	H metres	12	11	10	8.5	7	5	3.5	2						
BCm 15/50-MF	BC 15/50-MF	1.1	1.5		15	14	13	11.5	9.7	8	6.3	4.5	3	2				

Q = Flow rate H = Total manometric head

Tolerance of characteristic curves in compliance with EN ISO 9906 Grade 3B.

POS. COMPONENT CONSTRUCTION CHARACTERISTICS

1	PUMP BODY	Precision cast stainless steel AISI 304 with threaded port in compliance with ISO 228/1				
2	BASE	Stainless steel AISI 304				
3	IMPELLER	Precision cast stainless steel AISI 304 DOUBLE-CHANNEL type				
4	MOTOR CASING	Stainless steel AISI 304				
5	MOTOR CASING PLATE	Stainless steel AISI 304				
6	MOTOR SHAFT	Stainless steel AISI 304				
7	SHAFT WITH DOUBLE MECHANICAL SEAL SEPARATED BY AN OIL CHAMBER					
	Seal	Shaft	Position	Materials		
	<i>Model</i>	<i>Diameter</i>		<i>Stationary ring</i>	<i>Rotational ring</i>	<i>Elastomer</i>
	MG1-14D SIC	Ø 14 mm	Motor side	Silicon carbide	Graphite	NBR
			Pump side	Silicon carbide	Silicon carbide	NBR
8	BEARINGS	6203 ZZ / 6203 ZZ				

9	CAPACITOR		
	Pump	Capacitance	
	<i>Single-phase</i>	<i>(230 V or 240 V)</i>	<i>(110 V)</i>
	BCm 10/50-MF	20 µF 450 VL	30 µF - 250 VL
	BCm 15/50-MF	25 µF 450 VL	-

10 ELECTRIC MOTOR

BCm: single-phase 230 V - 50 Hz
with thermal overload protector incorporated into the winding

BC: three-phase 400 V - 50 Hz

- Insulation: class F
- Protection: IP X8

11 POWER CABLE

"H07 RN-F" type
(with Schuko plug for single-phase versions only)

Standard length 10 metres

12 FLOAT SWITCH
(only for single-phase versions)

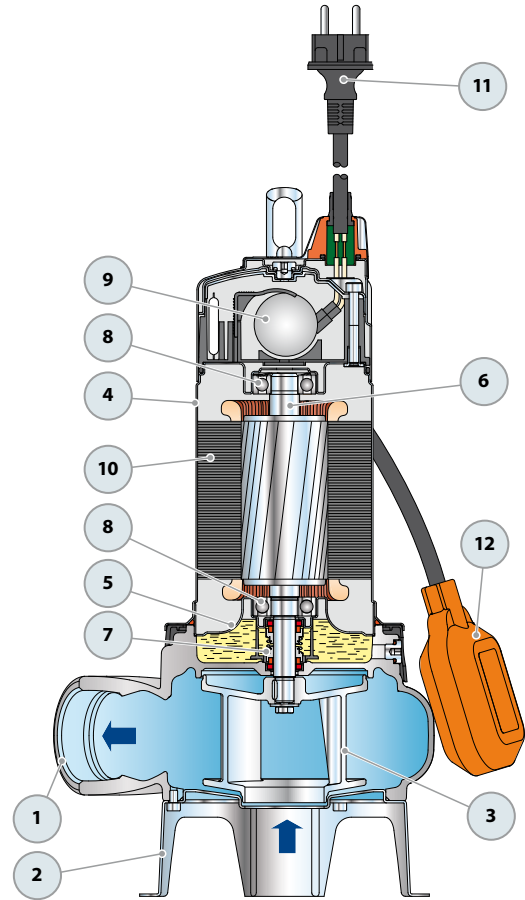

DIMENSIONS AND WEIGHT

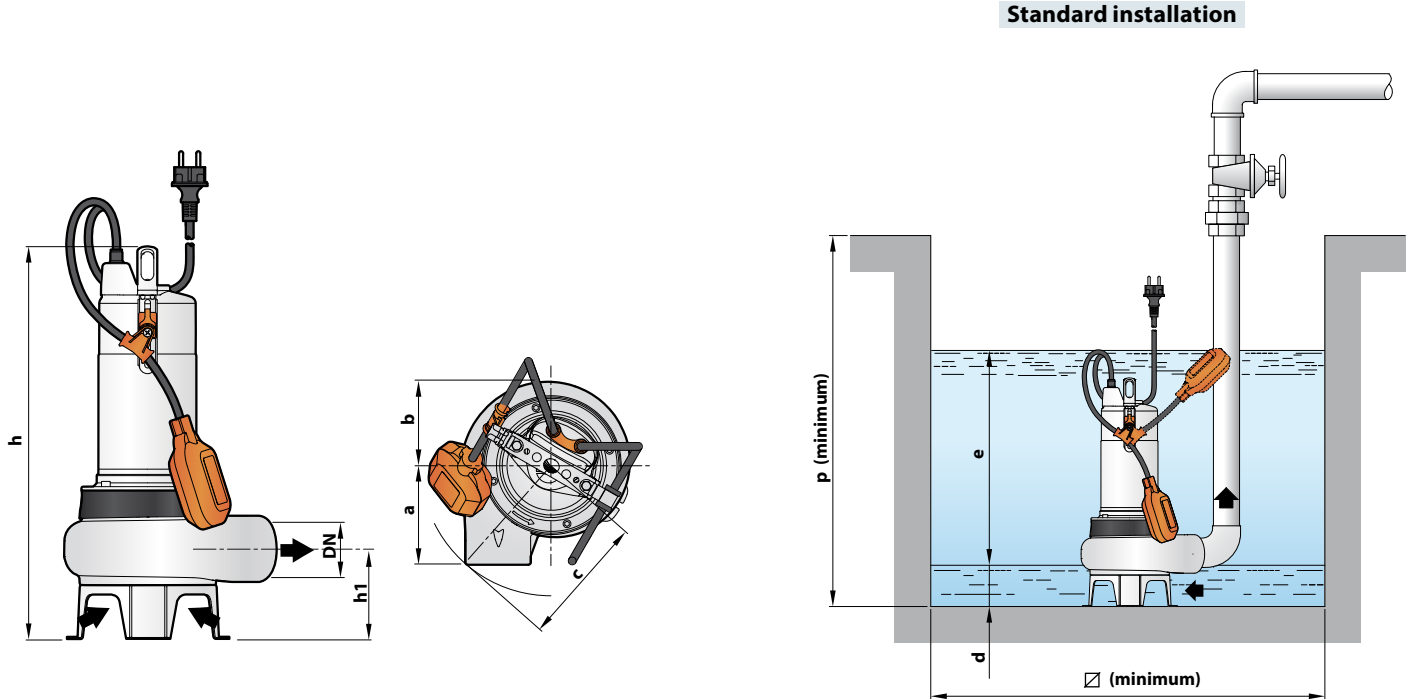

MODEL		PORT DN	Passage of solids	DIMENSIONS mm										kg	
Single-phase	Three-phase			a	b	c	h	h1	d	e	p	∅	1~	3~	
BCm 10/50-MF	BC 10/50-MF	2"	Ø 50 mm	112	98	150	431	102	60	variable	500	500	14.9	13.8	
BCm 15/50-MF	BC 15/50-MF						446								15.8

ABSORPTION

MODEL	VOLTAGE		
	230 V	240 V	110 V
BCm 10/50-MF	5.0 A	4.8 A	10.0 A
BCm 15/50-MF	8.2 A	7.9 A	-

MODEL	VOLTAGE			
	230 V	400 V	240 V	415 V
BC 10/50-MF	3.7 A	2.1 A	3.5 A	2.0 A
BC 15/50-MF	5.6 A	3.2 A	5.4 A	3.1 A

PALLETIZATION

MODEL		GROUPAGE n. pumps	CONTAINER n. pumps
Single-phase	Three-phase		
BCm 10/50-MF	BC 10/50-MF	54	72
BCm 15/50-MF	BC 15/50-MF	54	72